

# TC4047BP

查询TC4047BP供应商

C<sup>2</sup>MOS DIGITAL INTEGRATED CIRCUIT  
SILICON MONOLITHIC

捷多邦, 专业PCB打样工厂, 24小时加急出货

## TC4047BP LOW-POWER MONOSTABLE/ASTABLE MULTIVIBRATOR

TC4047BP is the multivibrator equipped with both astable function and mono-stable function, and retrigger operation and reset operation are also achievable.

For both operational modes, the pulse width can be varied by externally connected capacitor (C) and resistor (R).

Establish RETRIG="L", +TRIG="L", -TRIG="H" for astable operation and AST="L",  $\overline{\text{AST}}$ ="H" for mono-stable operation. (Refer to FUNCTION TABLE and OPERATING CONSIDERATIONS).

When EXTERNAL RESET input is set at "H", both operational modes of astable and mono-stable operations are reset to Q="L" and  $\overline{\text{Q}}$ ="H".

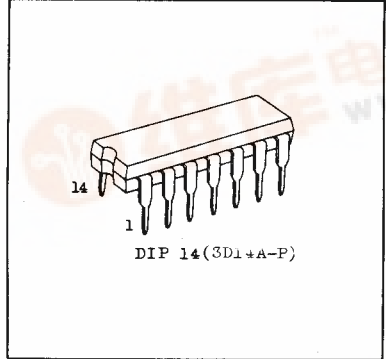

### ABSOLUTE MAXIMUM RATINGS

CHARACTERISTIC	SYMBOL	RATING	UNIT
DC Supply Voltage	V <sub>DD</sub>	V <sub>SS</sub> -0.5~V <sub>SS</sub> +20	V
Input Voltage	V <sub>IN</sub>	V <sub>SS</sub> -0.5~V <sub>DD</sub> +0.5	V
Output Voltage	V <sub>OUT</sub>	V <sub>SS</sub> -0.5~V <sub>DD</sub> +0.5	V
DC Input Current	I <sub>IN</sub>	±10	mA
Power Dissipation	P <sub>D</sub>	300	mW
Operating Temperature Range	T <sub>A</sub>	-40~85	°C
Storage Temperature Range	T <sub>stg</sub>	-65~150	°C
Lead Temp./Time	T <sub>sol</sub>	260°C · 10 sec	

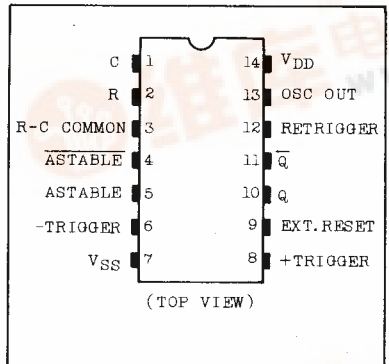

### PIN ASSIGNMENT

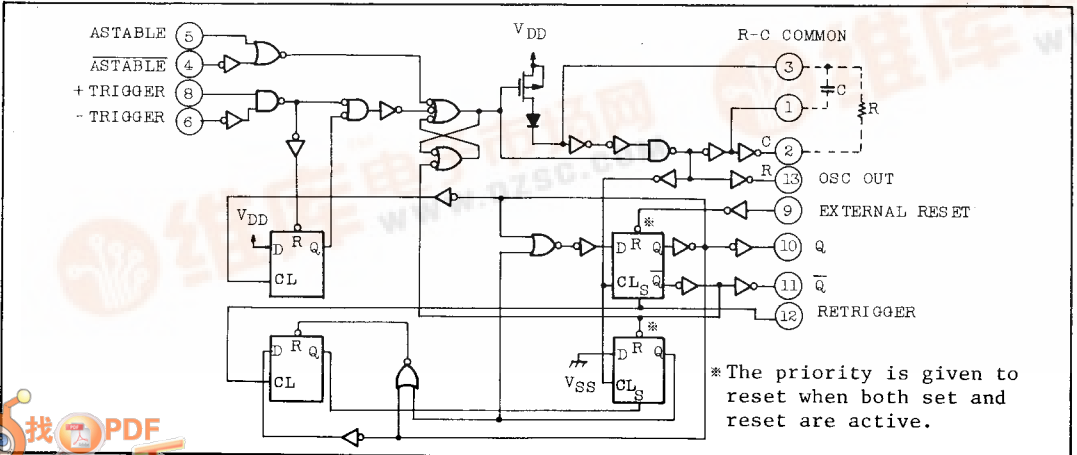

### LOGIC DIAGRAM



FUNCTION TABLE

FUNCTION							OUTPUT PERIOD OR PULSE WIDTH
	AST.	AST.	-TRIG.	+TRIG.	RETRIG.	EXT. RESET	
ASTABLE MULTIVIBRATOR							Q, $\bar{Q}$
Free Running	*	H	H	L	L	L	T=4.40RC
	L	*	H	L	L	L	OSC OUT
Inhibit	H	L	H	L	L	L	T=2.20RC
MONOSTABLE MULTIVIBRATOR							Q, $\bar{Q}$ $t_w=2.48RC$
Positive-Edge Trigger	H	L	L		L	L	
Negative-Edge Trigger	H	L		H	L	L	
Retrigger	H	L	L			L	
Note : External resistor and capacitance as LOGIC DIAGRAM * Don't care							

OPERATING CONSIDERATION

1. Astable Operation

By connecting inputs of -TRIGGER, +TRIGGER, RETRIGGER AND EXTERNAL RESET as shown in FUNCTION TABLE, stable operation of astable multivibrator can be obtained.

- When ASTABLE input is placed at "H", oscillation is continued regardless of  $\bar{A}STABLE$  input. When ASTABLE input is placed at "L", oscillation is continued regardless of ASTABLE input. (Free Running).
- Having ASTABLE input at "H", if ASTABLE input is set at "L", oscillation stops as long as it is at "L". (True Gating)
- Having ASTABLE input at "L", if ASTABLE input is set at "H", oscillation stops as long as it is at "H". (Complement Gating)

The oscillating period is determined by the external resistor and capacitor to be approximately  $T=2.2RC$ . This oscillation waveform is obtained as it is at OSC OUT and the oscillation waveform with double period and 50% duty cycle is obtained at outputs Q and  $\bar{Q}$ .

2. Mono-Stable Operation

By connecting ASTABLE and  $\bar{A}STABLE$  inputs to "L" level and "H" level respectively, mono-stable multivibrator with the capabilities of retrigger operation and external asynchronous reset operation is obtained. This is normally used with RETRIGGER input and EXTERNAL RESET input connected to "L" level.

- When -TRIGGER input is set to "L", mono-stable pulse is obtained at the rising edge of +TRIGGER input at Q and  $\bar{Q}$  outputs. (Positive-edge Trigger)
  - When +TRIGGER input is set to "H", mono-stable pulse is obtained at the falling edge of -TRIGGER input at Q and  $\bar{Q}$  outputs. (Negative-edge Trigger)
  - Keeping-TRIGGER input at "L", if the same pulse input ( $T < 2.48RC$ ) is applied to both +TRIGGER input and RETRIGGER input, retrigger operation is achieved. However, the last transition of this pulse input must be negative going. (Retrigger)
- The width of mono-stable pulse is determined by the external resistor and capacitor to be approximately  $t_w=2.48RC$ .

Note : The external resistor and capacitor should be connected as shown by broken lines in the logical diagram for both mono-stable and astable operations.  
The capacitor used should be non-directional.

# TC4047BP

## TIMING DIAGRAM

### (ASTABLE MODE)

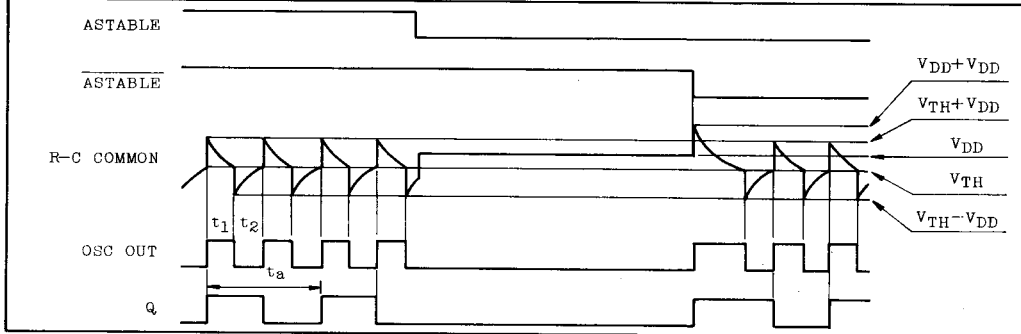

$$t_1 = -RC \ln \frac{V_{TH}}{V_{DD} + V_{TH}}, \quad t_2 = -RC \ln \frac{V_{DD} - V_{TH}}{2V_{DD} - V_{TH}}$$

$$t_a = 2(t_1 + t_2) = -2RC \ln \frac{V_{TH}(V_{DD} - V_{TH})}{(V_{DD} + V_{TH})(2V_{DD} - V_{TH})}$$

TYPICAL :  $V_{TH} = 1/2V_{DD}$      $t_a = 4.40RC$

### (MONO STABLE MODE)

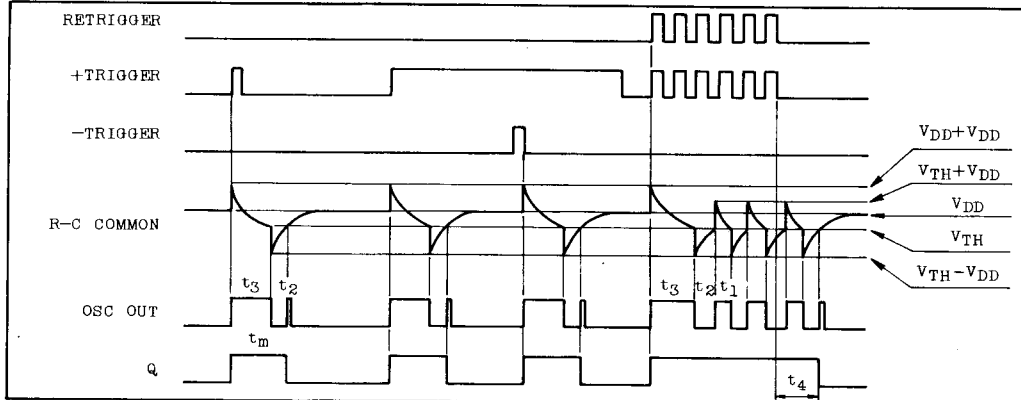

$$t_1 = -RC \ln \frac{V_{TH}}{V_{DD} + V_{TH}}, \quad t_2 = -RC \ln \frac{V_{DD} - V_{TH}}{2V_{DD} - V_{TH}}$$

$$t_3 = -RC \ln \frac{V_{TH}}{2V_{DD}}, \quad t_1 + t_2 < t_4 < 2(t_1 + t_2)$$

$$t_m = t_3 + t_2 = -RC \ln \frac{V_{TH}(V_{DD} - V_{TH})}{2V_{DD}(2V_{DD} - V_{TH})}$$

TYPICAL :  $V_{TH} = 1/2V_{DD}$      $t_m = 2.48RC$

Note :  $V_{TH}$ : Threshold Level



# TC4047BP

## STATIC ELECTRICAL CHARACTERISTICS (V<sub>SS</sub>=0V)

CHARACTERISTIC	SYM-BOL	TEST CONDITION	V <sub>DD</sub> (V)	-40°C		25°C			85°C		UNIT	
				MIN.	MAX.	MIN.	TYP.	MAX.	MIN.	MAX.		
Input Current	"H" Level	I <sub>IH</sub>	V <sub>IH</sub> =18V	18	-	0.1	-	10 <sup>-5</sup>	0.1	-	1.0	μA
	"L" Level	I <sub>IL</sub>	V <sub>IL</sub> =0V	18	-	-0.1	-	-10 <sup>-5</sup>	-0.1	-	-1.0	
Quiescent Device Current	I <sub>DD</sub>	V <sub>IN</sub> =V <sub>SS</sub> , V <sub>DD</sub> *	5	-	1	-	0.005	1	-	30	μA	
			10	-	2	-	0.010	2	-	60		
			15	-	4	-	0.015	4	-	120		

\* All valid input combinations.

## DYNAMIC ELECTRICAL CHARACTERISTICS (T<sub>a</sub>=25°C, V<sub>SS</sub>=0V, C<sub>L</sub>=50pF)

CHARACTERISTIC	SYMBOL	TEST CONDITION	V <sub>DD</sub> (V)	MIN.	TYP.	MAX.	UNIT
			10	-	50	100	
			15	-	40	80	
Output Transition Time (High to Low)	t <sub>THL</sub>		5	-	80	200	ns
			10	-	50	100	
			15	-	40	80	
Propagation Delay Time (ASTABLE, $\overline{\text{ASTABLE}}$ - OSC OUT)	t <sub>pLH</sub> t <sub>pHL</sub>		5	-	290	580	ns
			10	-	110	220	
			15	-	70	160	
Propagation Delay Time (ASTABLE, $\overline{\text{ASTABLE}}$ - Q, $\overline{\text{Q}}$ )	t <sub>pLH</sub> t <sub>pHL</sub>		5	-	480	960	ns
			10	-	170 <sup>1</sup>	350	
			15	-	110	250	
Propagation Delay Time (+TRIGGER, -TRIGGER - Q, $\overline{\text{Q}}$ )	t <sub>pLH</sub> t <sub>pHL</sub>		5	-	550	1100	ns
			10	-	200	450	
			15	-	130	300	
Propagation Delay Time (RETRIGGER - Q, $\overline{\text{Q}}$ )	t <sub>pLH</sub> t <sub>pHL</sub>		5	-	250	600	ns
			10	-	100	300	
			15	-	65	200	
Propagation Delay Time (EXTERNAL RESET - Q, $\overline{\text{Q}}$ )	t <sub>pLH</sub> t <sub>pHL</sub>		5	-	270	540	ns
			10	-	100	200	
			15	-	65	140	

DYNAMIC ELECTRICAL CHARACTERISTICS (Ta=25°C, VSS=0V, CL=50pF)

CHARACTERISTIC	SYMBOL	TEST CONDITION	VDD(V)	MIN.	TYP.	MAX.	UNIT
Min. Pulse Width (+TRIGGER, -TRIGGER)	t <sub>WH</sub> t <sub>WL</sub>		5	-	370	740	ns
			10	-	130	260	
			15	-	70	140	
Min. Pulse Width (EXT. RESET)	t <sub>WH</sub>		5	-	100	200	ns
			10	-	35	100	
			15	-	25	60	
Min. Pulse Width (RETRIGGER)	t <sub>WH</sub>		5	-	95	600	ns
			10	-	40	230	
			15	-	25	150	
Max. Clock Input Rise Time	t <sub>r</sub>		5	20	-	-	μs
			10	2.5	-	-	
Max. Clock Input Fall Time	t <sub>f</sub>		5	1.0	-	-	
			10				
Deviation from 50% Duty Factor (Q, $\bar{Q}$ )		$\frac{t_w(H) - t_w(L)}{t_w(L)}$ × 100 (%)	5	-	±0.2	-	%
			10	-	±0.2	-	
			15	-	±0.1	-	
Input Capacitance	C <sub>IN</sub>			-	5	7.5	pF

# TC4047BP

## WAVEFORMS FOR MEASUREMENT OF DYNAMIC CHARACTERISTICS

WAVEFORM 1.

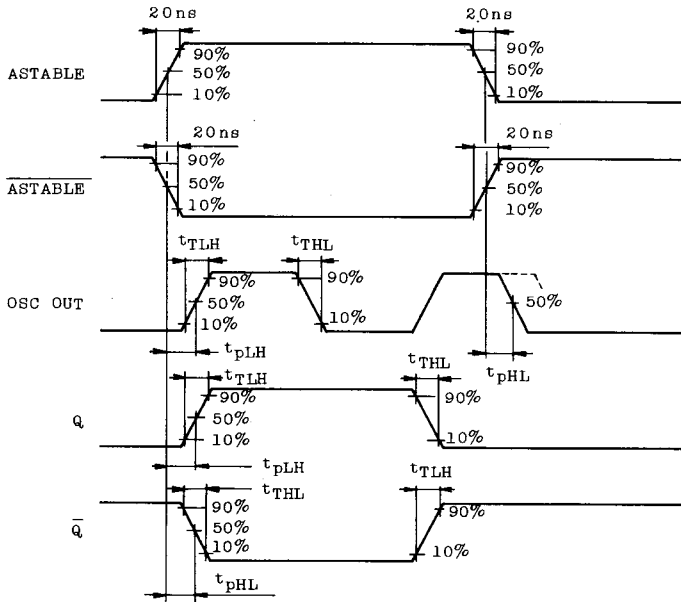

WAVEFORM 2.

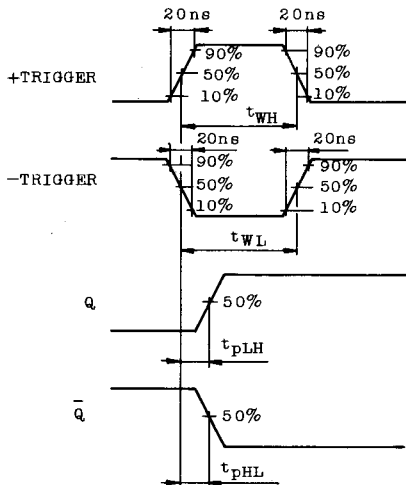

WAVEFORM 3.

