

## TC4063BP/TC4063BF 4-BIT MAGNITUDE COMPARATOR

TC4063BP/BF is weighted comparator which compares magnitude of 4 bits input data B<sub>0</sub> through B<sub>3</sub>. When TC4063BP/BF is used, the signals of larger, smaller and equal can be obtained at three output lines by the cascade input mode of three lines of (A>B)<sub>IN</sub>, (A=B)<sub>IN</sub> and (A<B)<sub>IN</sub>.

Cascade connection of n number of TC4063BP/BF's easily realizes magnitude comparator of 4 × n bits.

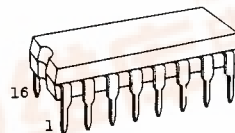

DIP 16 (3D16A-P)

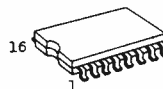

MFP 16 (F16GC-P)

### ABSOLUTE MAXIMUM RATINGS

CHARACTERISTIC	SYMBOL	RATING	UNIT
DC Supply Voltage	V <sub>DD</sub>	V <sub>SS</sub> -0.5 ~ V <sub>SS</sub> +20	V
Input Voltage	V <sub>IN</sub>	V <sub>SS</sub> -0.5 ~ V <sub>DD</sub> +0.5	V
Output Voltage	V <sub>OUT</sub>	V <sub>SS</sub> -0.5 ~ V <sub>DD</sub> +0.5	V
DC Input Current	I <sub>IN</sub>	±10	mA
Power Dissipation	P <sub>D</sub>	300(DIP)/180(MFP)	mW
Operating Temperature Range	T <sub>A</sub>	-40 ~ 85	°C
Storage Temperature Range	T <sub>stg</sub>	-65 ~ 150	°C
Lead Temp./Time	T <sub>sol</sub>	260°C · 10 sec	

### PIN ASSIGNMENT

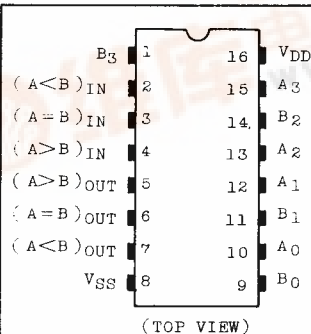

### LOGIC DIAGRAM

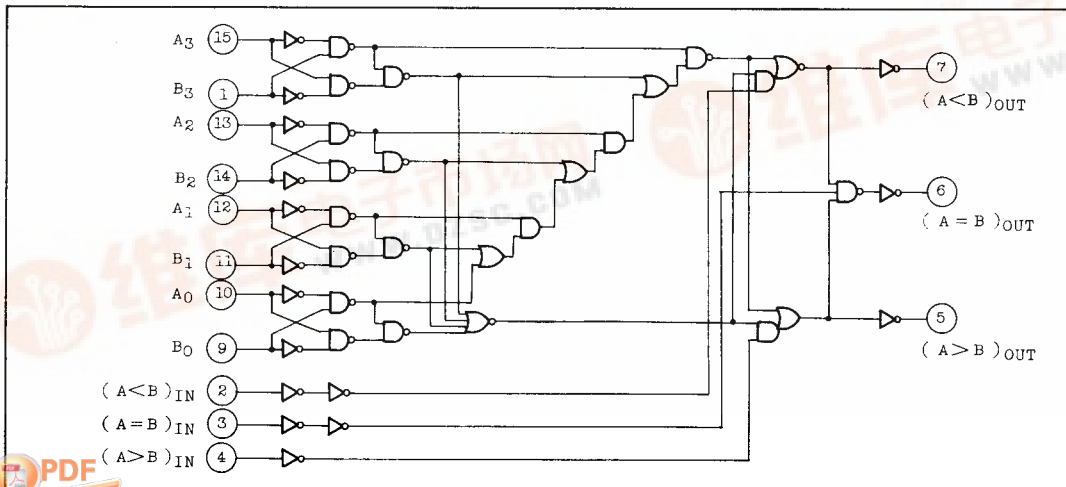



STATIC ELECTRICAL CHARACTERISTICS (V<sub>SS</sub>=0V)

CHARACTERISTIC	SYM-BOL	TEST CONDITION	V <sub>DD</sub> (V)	-40°C		25°C			85°C		UNIT	
				MIN.	MAX.	MIN.	TYP.	MAX.	MIN.	MAX.		
Output Low Current	I <sub>OL</sub>	V <sub>OL</sub> =0.4V	5	0.61	-	0.51	1.5	-	0.42	-	mA	
		V <sub>OL</sub> =0.5V	10	1.5	-	1.3	3.8	-	1.1	-		
		V <sub>OL</sub> =1.5V	15	4.0	-	3.4	15.0	-	2.8	-		
		V <sub>IN</sub> =V <sub>SS</sub> , V <sub>DD</sub>										
Input High Voltage	V <sub>IH</sub>	V <sub>OUT</sub> =0.5V, 4.5V	5	3.5	-	3.5	2.75	-	3.5	-	V	
		V <sub>OUT</sub> =1.0V, 9.0V	10	7.0	-	7.0	5.5	-	7.0	-		
		V <sub>OUT</sub> =1.5V, 13.5V	15	11.0	-	11.0	8.25	-	11.0	-		
		I <sub>OUT</sub>   < 1μA										
Input Low Voltage	V <sub>IL</sub>	V <sub>OUT</sub> =0.5V, 4.5V	5	-	1.5	-	2.25	1.5	-	1.5	V	
		V <sub>OUT</sub> =1.0V, 9.0V	10	-	3.0	-	4.5	3.0	-	3.0		
		V <sub>OUT</sub> =1.5V, 13.5V	15	-	4.0	-	6.75	4.0	-	4.0		
		I <sub>OUT</sub>   < 1μA										
Input Current	"H" Level	I <sub>IH</sub>	V <sub>IH</sub> =18V	18	-	0.1	-	10 <sup>-5</sup>	0.1	-	1.0	μA
	"L" Level	I <sub>IL</sub>	V <sub>IL</sub> =0V	18	-	-0.1	-	-10 <sup>-5</sup>	-0.1	-	-1.0	
Quiescent Device Current	I <sub>DD</sub>	V <sub>IN</sub> =V <sub>SS</sub> , V <sub>DD</sub> *	5	-	5	-	0.005	5	-	150	μA	
			10	-	10	-	0.010	10	-	300		
			15	-	20	-	0.015	20	-	600		

\* All valid input combinations.

DYNAMIC ELECTRICAL CHARACTERISTICS (T<sub>a</sub>=25°C, V<sub>SS</sub>=0V, C<sub>L</sub>=50pF)

CHARACTERISTIC	SYMBOL	TEST CONDITION	V <sub>DD</sub> (V)	MIN.	TYP.	MAX.	UNIT
	10	-	50	100			
	15	-	40	80			
Output Transition Time (High to Low)	t <sub>THL</sub>		5	-	80	200	ns
		10	-	50	100		
		15	-	40	80		
Propagation Delay Time (COMPARING INPUTS - OUTPUTS)	t <sub>pLH</sub> t <sub>pHL</sub>		5	-	340	1250	ns
			10	-	140	500	
			15	-	100	350	

# TC4063BP/BF

DYNAMIC ELECTRICAL CHARACTERISTICS ( $T_a=25^\circ\text{C}$ ,  $V_{SS}=0\text{V}$ ,  $C_L=50\text{pF}$ )

CHARACTERISTIC	SYMBOL	TEST CONDITION	$V_{DD}$ (V)	MIN.	TYP.	MAX.	UNIT
Propagation Delay Time (CASCADING INPUTS - OUTPUTS)	$t_{pLH}$		5	-	280	1000	ns
	$t_{pHL}$		10	-	110	400	
			15	-	90	280	
Input Capacitance	$C_{IN}$			-	5	7.5	pF

## WAVEFORM FOR MEASUREMENT OF DYNAMIC CHARACTERISTICS

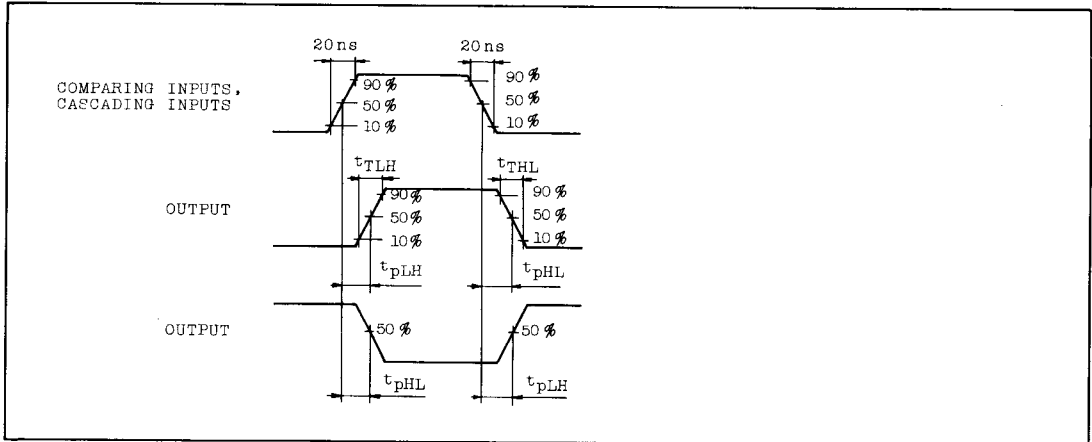

## APPLICATION CIRCUIT

