

查询TDA2161供应商

捷多邦, 专业PCB打样工厂, 24小时加急出货

# TDA 2161

## LINEAR INTEGRATED CIRCUIT

### SYNCHRONOUS DEMODULATOR AND RGB MATRIX FOR COLOUR TV WITH ON SCREEN DISPLAY FACILITY

The TDA 2161 is a monolithic integrated circuit for demodulating and matrixing chroma signals. It is used for RGB cathode driving of colour pictures tubes and is directly coupled to the video output stages. The TDA 2161 is encapsulated in a 16-lead dual in-line plastic package and its main features are:

- High stability of DC output voltages ensured by applying heavy feedback from the output stages
- Large bandwidth
- Tight thermal coupling between the three channels
- Low subcarrier leakage due to integrated active filters
- Large black level adjustment range
- Large dynamic swing of the output signals
- High electrical stability of RGB amplifiers assured by internal frequency compensations
- Box blanking for characters display on screen.

### ABSOLUTE MAXIMUM RATINGS

$V_s$	Supply voltage (pin 9)	15	V
$V_{12}$	Voltage at pin 12	$V_s$	
$P_{tot}$	Total power dissipation at $T_{amb} \leq 70^\circ\text{C}$	800	mW
$T_{stg}$	Storage temperature	-55 to 150	$^\circ\text{C}$
$T_{op}$	Operating temperature	0 to 70	$^\circ\text{C}$

ORDERING NUMBER: TDA 2161

### MECHANICAL DATA

Dimensions in mm

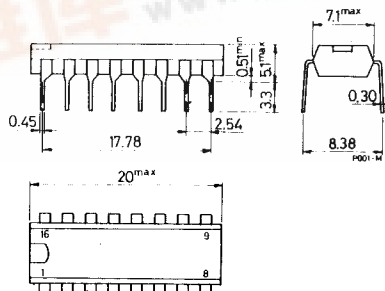

# TDA 2161

## CONNECTION AND BLOCK DIAGRAMS (top view)

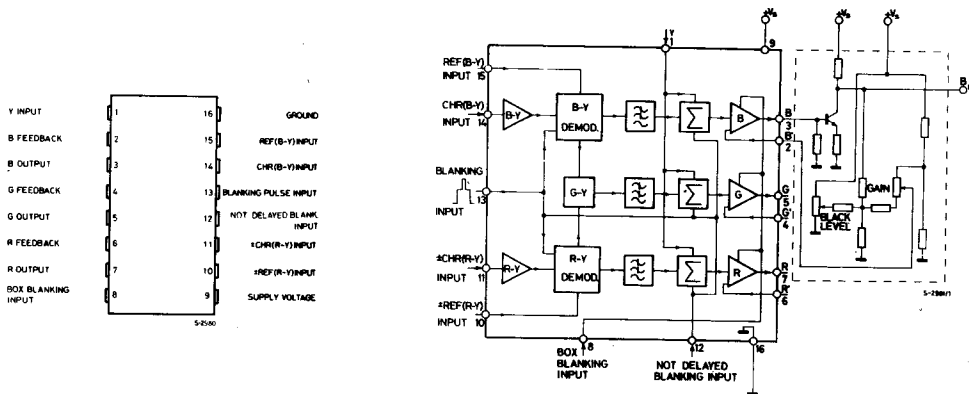

## TEST CIRCUIT

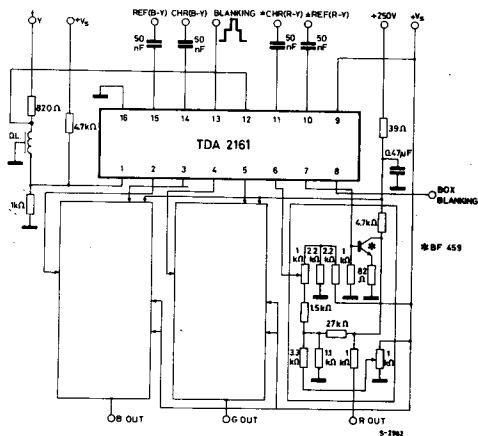

## THERMAL DATA

$R_{th j-amb}$  Thermal resistance junction-ambient

max 100 °C/W



# TDA 2161

## ELECTRICAL CHARACTERISTICS

(Refer to the test circuit,  $V_s = 12V$ ,  $T_{amb} = 25^\circ C$  unless otherwise specified)

Parameter		Test conditions	Min.	Typ.	Max.	Unit
$V_s$	Supply voltage (pin 9)		10.8		13.2	V
$I_s$	Supply current (pin 9)			35	46	mA
$V_1$	Peak to peak luminance input signal	CRT cathodes signal = 100 Vpp		1		V
$V_1$	Black level voltage of luminance input signal			2.2		V
$R_1$	Luminance input resistance			50		k $\Omega$
$G_V$	Gain of luminance channels (including video output stages)	$f = 0.5 \text{ MHz}$ $V_i = 1 \text{ Vpp}$		100		—
$B_V$	Frequency response of luminance channels (-3 dB)	$V_i = 200 \text{ mVpp}$		6		MHz
$V_8$	Box blanking input pulse		2.5		5	V
$V_{11}$	Chr. (R-Y) peak to peak input signal for max. output	$f = 4.4 \text{ MHz}$ Output signals linearity factor: $m = 0.7$		470		mV
$V_{14}$	Chr. (B-Y) peak to peak input signal for max. output			350		mV
$R_{11}$	Chr. (R-Y) input resistance	$f = 4.4 \text{ MHz}$		1		k $\Omega$
$C_{11}$	Chr. (R-Y) input capacitance				5	pF
$R_{14}$	Chr. (B-Y) input resistance			1		k $\Omega$
$C_{14}$	Chr. (B-Y) input capacitance				5	pF
$V_{10}$	$\pm$ Ref. (R-Y) peak to peak input signal			0.8		V
$R_{10}$	$\pm$ Ref. (R-Y) input resistance			2		k $\Omega$
$V_{15}$	Ref. (B-Y) input signal			0.8		V
$R_{15}$	Ref. (B-Y) input resistance			2		k $\Omega$
$G_{R-Y}$	Gain of (R-Y) demodulator (note)	$f = 4.4 \text{ MHz}$ $V_i = 50 \text{ mVpp}$		3.3		—

# TDA 2161

## ELECTRICAL CHARACTERISTICS (continued)

Parameter		Test conditions	Min.	Typ.	Max.	Unit
$G_{B-Y}$ $G_{R-Y}$	(B-Y) demodulator gain to (R-Y) demodulator gain ratio	$f = 4.4 \text{ MHz}$ $V_i = 50 \text{ mVpp}$ $V_{14} = 50 \text{ mVpp}$ $V_{10} = V_{15} = 700 \text{ mVpp}$		1.78		—
$V_{G-Y}$ $V_{R-Y}$	(G-Y) to (R-Y) matrix ratio	$f = 4.4 \text{ MHz}$ $V_{11} = 50 \text{ mVpp}$ $V_{10} = 700 \text{ mVpp}$		-0.51		—
$V_{G-Y}$ $V_{B-Y}$	(G-Y) to (B-Y) matrix ratio	$f = 4.4 \text{ MHz}$ $V_{14} = 50 \text{ mVpp}$ $V_{15} = 700 \text{ mVpp}$		-0.19		—
$B_{Chr}$	Frequency response of colour difference channels (-3 dB)	$V_{11} = 0.1 \text{ Vpp}$ $V_{14} = 0.1 \text{ Vpp}$ $V_{10} = V_{15} = 700 \text{ mVpp}$	1	1.2		MHz
$V_3$	B output voltage swing	$m \geq 0.7$		3		V
$V_5$	G output voltage swing			3		V
$V_7$	R output voltage swing			3		V
$V_{13}$	Blanking input voltage		1			V
$I_{13}$	Blanking input current		10			$\mu\text{A}$
$\Delta V_o$	DC differential voltage between RGB outputs (at c.r.t. cathodes)	$V_1 = V_{12}$			5	V
	Residual carrier at the CRT cathodes				2	Vpp

## APPLICATION INFORMATION

### Pin 1 – Luminance input

The luminance signal enters at pin 1 with a typical black to white amplitude of 1V and a black level of 2.2V. The typical input impedance is 50 k $\Omega$ /5 pF.

### Pin 2 – Blue channel feedback

The DC working points and gains of the output stages and the IC amplifier stages are stabilized by the feedback circuits. The gain and black level of the RGB output stages are adjusted to have the black and white setting points on the picture tube, by means of the potentiometers in the feedback paths.

# TDA 2161

## APPLICATION INFORMATION (continued)

### Pin 3 - Blue signal output

The low output impedance and the dynamic swing of the B signal output allows direct driving of the video output stage.

### Pin 4 - Green channel feedback (see pin 2)

### Pin 5 - Green signal output (see pin 3)

### Pin 6 - Red channel feedback (see pin 2)

### Pin 7 - Red signal output (see pin 3)

### Pin 8 - Box blanking input

Positive going pulses are required. The high impedance input is TTL compatible.

### Pin 9 - Positive supply

The operating supply voltage of the device ranges from 10.8 to 13.2V.

### Pin 10 - $\pm$ (R-Y) reference input

A DC blocking capacitor is required to avoid DC unbalance of the demodulator. A minimum peak to peak signal of 0.5V is required to ensure good demodulator performance.

### Pin 11 - $\pm$ (R-Y) chroma signal input

The (B-Y) and (R-Y) demodulators have different amplification gain to compensate for the different attenuation of the chrominance signal components. This results in a gain of 3.3 for the (R-Y) detector while the relationship between the gain of the (B-Y) detector and that of the (R-Y) detector is 1.78. The gain is calculated on the peak-to-peak values at the input and output of the demodulator, using standard colour bars as a test signal. To obtain maximum output, the chrominance input signals must have a typical value of 350 mVpp for (B-Y) and 370 mVpp for (R-Y). In addition to the chrominance signal components, the burst also arrives at the demodulators. If demodulated, the burst would alter the blanking level on the video output stages. The demodulators must therefore be shut off during flyback and this is done by the sandcastle pulse applied at pin 13 of the IC. The (G-Y) component is obtained from the outputs of the two demodulators by means of the passive matrix according to the equation:  $(G-Y) = -0.51 (R-Y) - 0.19 (B-Y)$ .

### Pin 12 - Not delayed blanking input

The not delayed blanking pulse, available before the luminance delay line, is combined internally with the blanking pulse applied at pin 13.

### Pin 13 - Blanking input

The demodulators are blanked by applying at pin 13 a positive pulse which must exceed the internal threshold of 1.5V. The input impedance is 5 k $\Omega$ .

### Pin 14 - (B-Y) chroma signal input (see pin 11)

### Pin 15 - (B-Y) reference input (see pin 10)

### Pin 16 - Ground

