



TDA2824

DUAL POWER AMPLIFIER

- SUPPLY VOLTAGE DOWN TO 3 V
- HIGH SVR
- LOW CROSSOVER DISTORTION
- LOW QUIESCENT CURRENT
- BRIDGE OR STEREO CONFIGURATION

DESCRIPTION

The TDA2824 is a monolithic integrated circuit in 12+2+2 powerdip, intended for use as dual audio power amplifier in portable radios and TV sets.

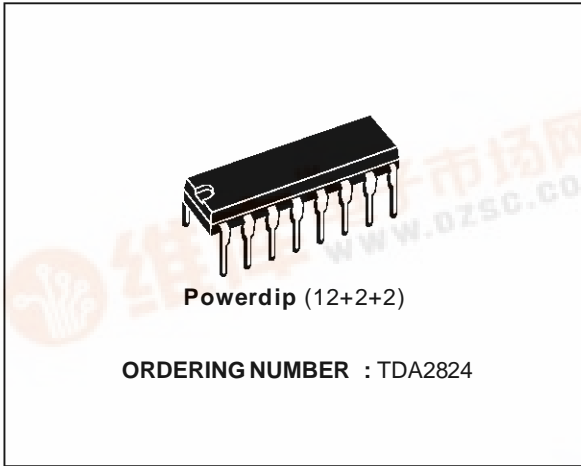

TYPICAL APPLICATION CIRCUIT (Stereo)

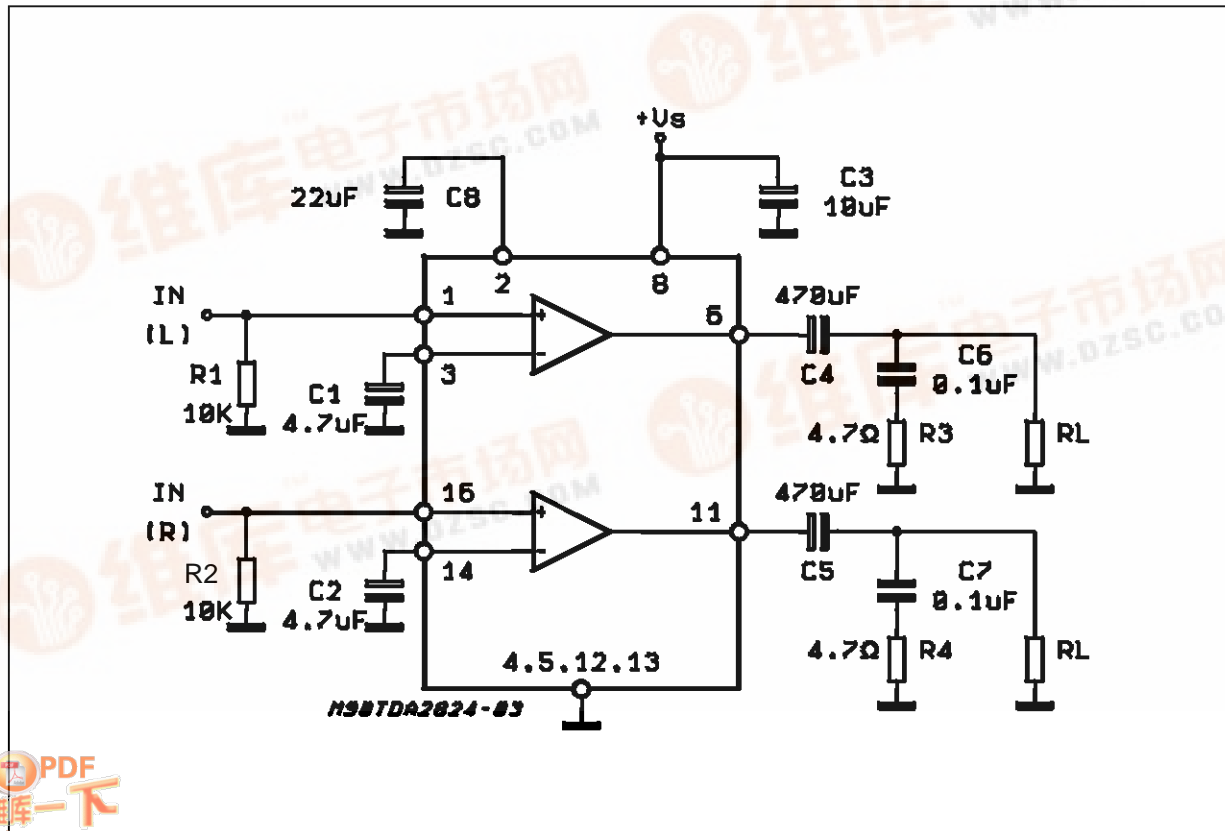

TDA2824

PIN CONNECTION

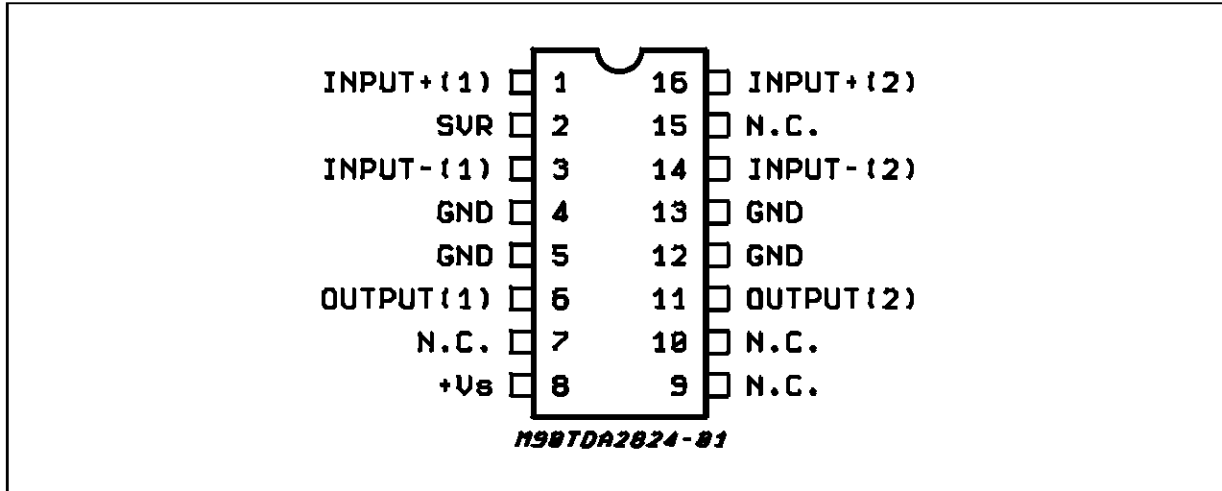

SCHEMATIC DIAGRAM

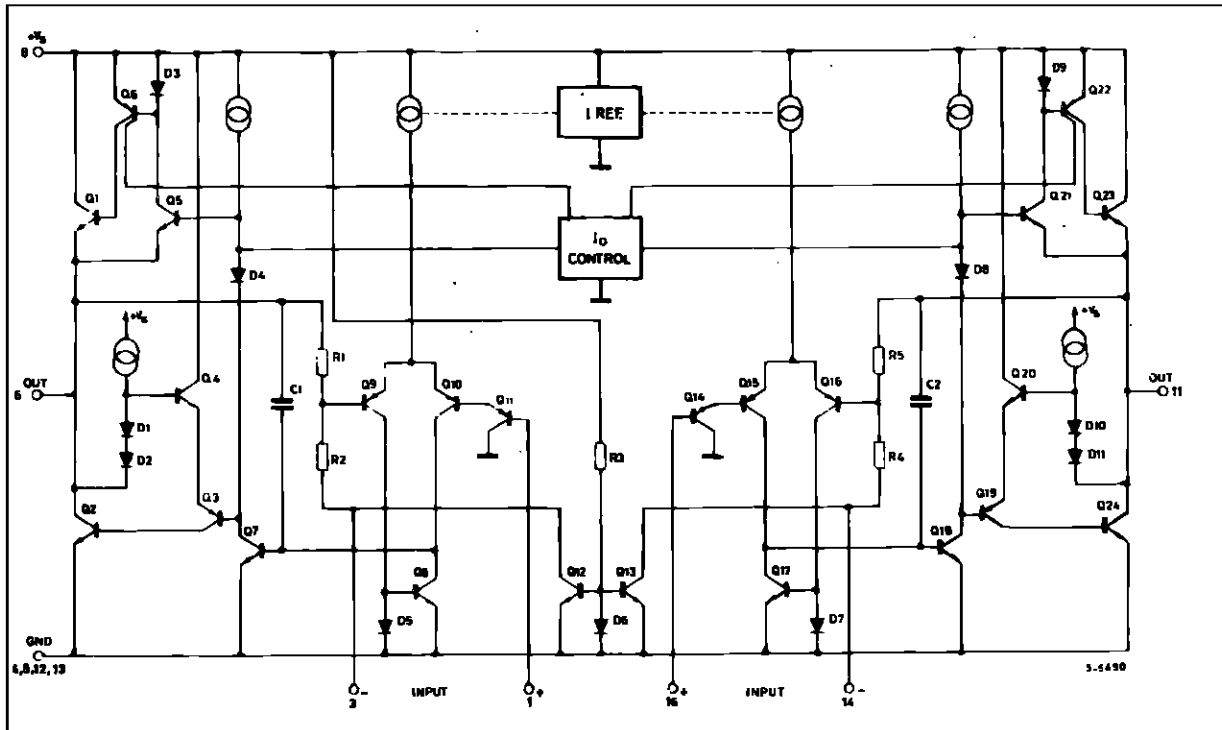

ABSOLUTE MAXIMUM RATINGS

Symbol	Parameter	Value	Unit
V_s	Supply Voltage	16	V
I_o	Output Peak Current	1.5	A
P_{tot}	Total Power Dissipation at $T_{amb} = 50^\circ\text{C}$ $T_{amb} = 70^\circ\text{C}$	1.25 4	W
T_{stg}, T_j	Storage and Junction Temperature	-40 to 150	$^\circ\text{C}$

THERMAL DATA

Symbol	Parameter	Value	Unit
$R_{th\ j-amb}$	Thermal Resistance Junction-ambient	Max. 80	$^{\circ}C/W$
$R_{th\ j-case}$	Thermal Resistance Junction-case	Max. 20	$^{\circ}C/W$

ELECTRICAL CHARACTERISTICS ($V_S = 6V$, $T_{amb} = 25^{\circ}C$, unless otherwise specified)

Symbol	Parameter	Test Conditions	Min.	Typ.	Max.	Unit
--------	-----------	-----------------	------	------	------	------

STEREO (test circuit of fig. 1)

V_S	Supply Voltage		3		15	V
V_O	Quiescent Output Voltage	$V_S = 9V$ $V_S = 9V$		4 2.7		V V
I_d	Quiescent Drain Current			6	12	mA
I_b	Input Bias Current			100		nA
P_O	Output Power (each channel)	$d = 10\%$ $f = 1KHz$ $V_S = 9V$ $R_L = 4\Omega$ $V_S = 6V$ $R_L = 4\Omega$ $V_S = 4.5V$ $R_L = 4\Omega$	1.3 0.45	1.7 0.65 0.32		W W W
d	Distortion	$V_S = 9V$, $f = 1KHz$ $R_L = 8\Omega$, $P_O = 0.5W$		0.2		%
G_V	Closed Loop Voltage Gain	$f = 1KHz$	36	39	41	dB
R_i	Input Resistance	$f = 1KHz$	100			$K\Omega$
e_N	Total Input Noise	$R_S = 10K\Omega$ $B = 22Hz$ to $22KHz$ Curve A		2.5 2		μV μV
SVR	Supply Voltage Rejection	$f = 100Hz$	40	50		dB
CS	Channel Separation	$R_S = 10K\Omega$ $f = 1KHz$		50		dB

BRIDGE (test circuit of fig. 2)

V_S	Supply Voltage		3		15	V
V_{OS}	Output Offset Voltage	$R_L = 8\Omega$			60	mV
I_b	Input Bias Current			100		nA
P_O	Output Power	$d = 10\%$ $f = 1KHz$ $V_S = 9V$ $R_L = 8\Omega$ $V_S = 6V$ $R_L = 8\Omega$ $V_S = 4.5V$ $R_L = 4\Omega$	2.5 0.9	3.2 1.35 1		W W W
d	Distortion ($f = 1KHz$)	$R_L = 8\Omega$ $P_O = 0.5W$		0.2		%
G_V	Closed Loop Voltage Gain	$f = 1KHz$		39		dB
e_N	Total Input Noise	$R_S = 10K\Omega$ $B = 22Hz$ to $22KHz$ Curve A		3 2.5		mV μV
SVR	Supply Voltage Rejection	$f = 100Hz$	48	60		dB

TDA2824

Figure 1 : Test Circuit (stereo).

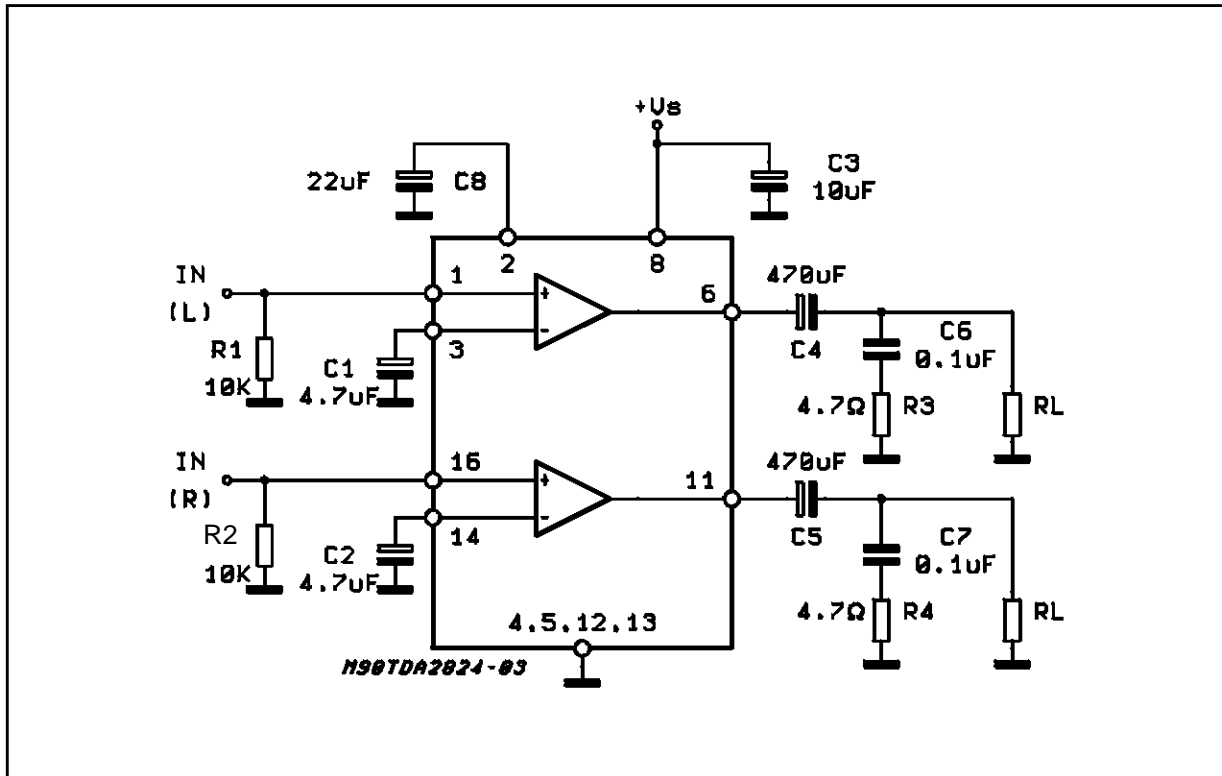

Figure 2: P.C. Board and Component Layout of the Circuit of Figure 1. (1:1 scale)

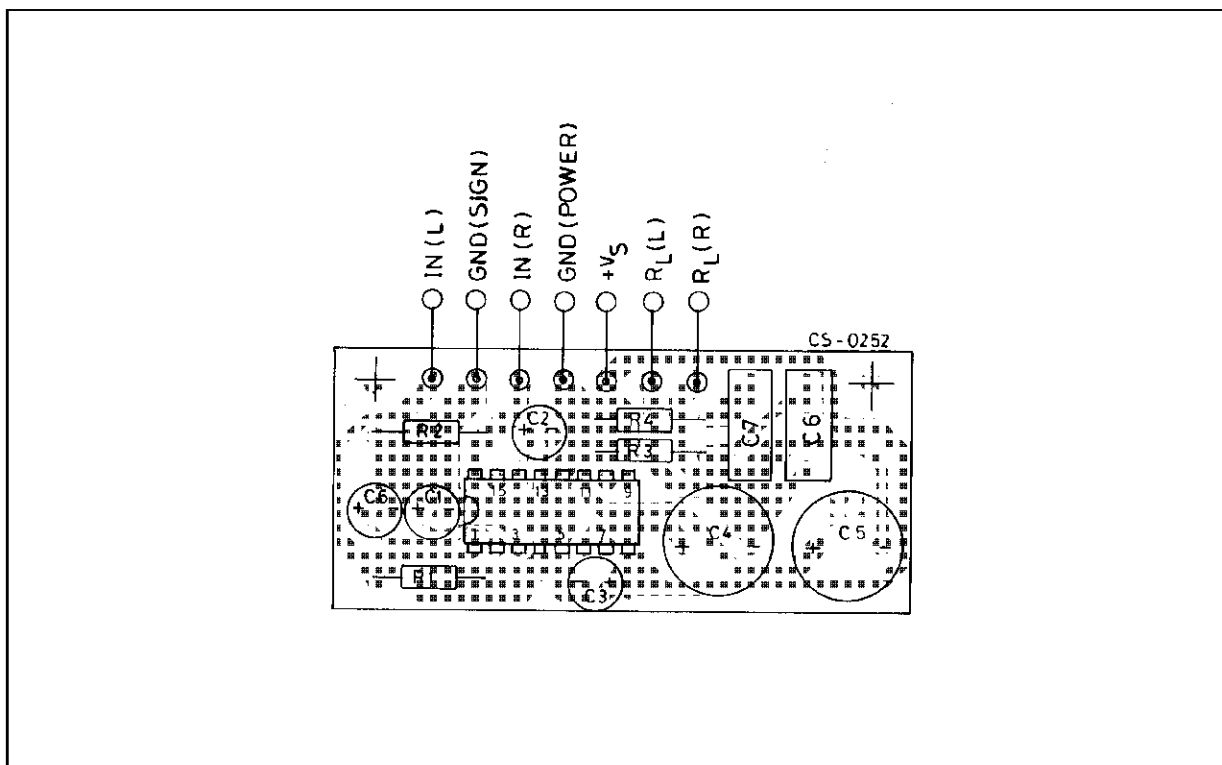

Figure 3 : Test Circuit (bridge).

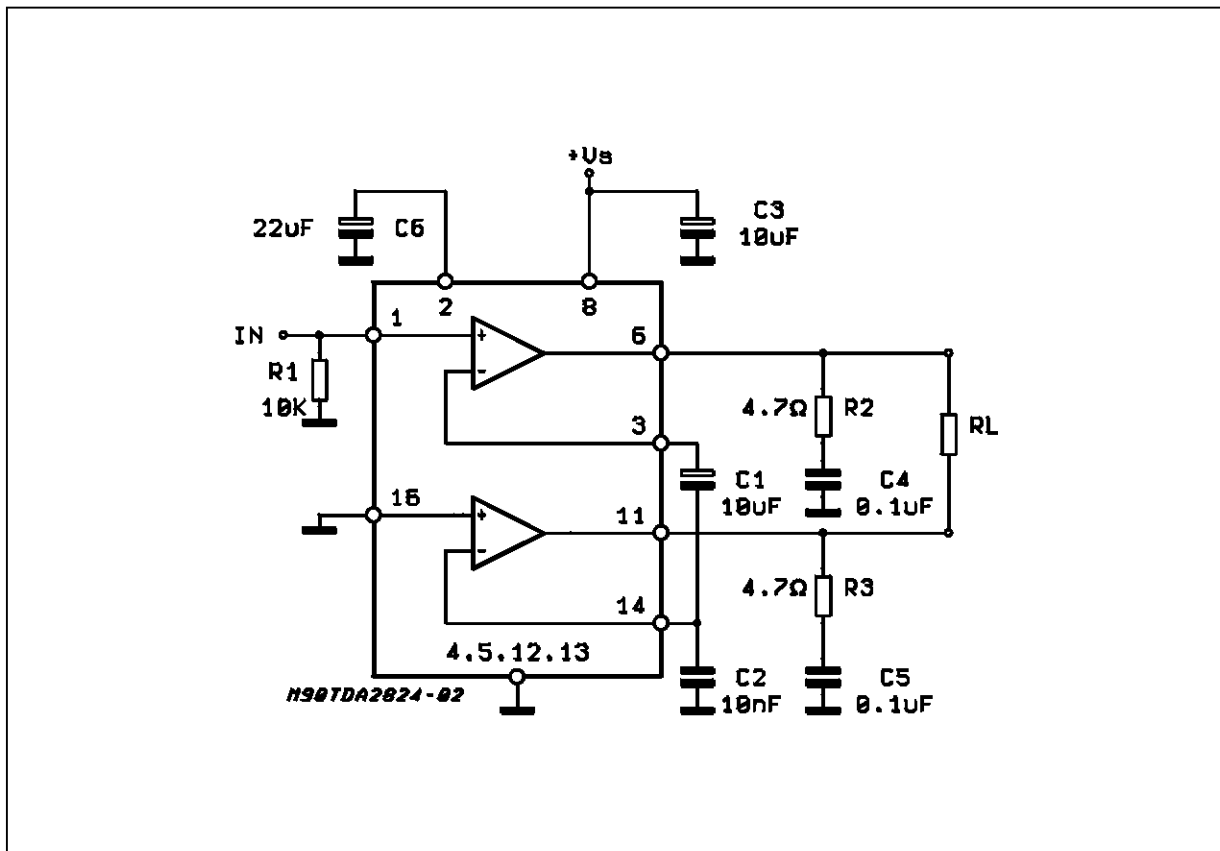
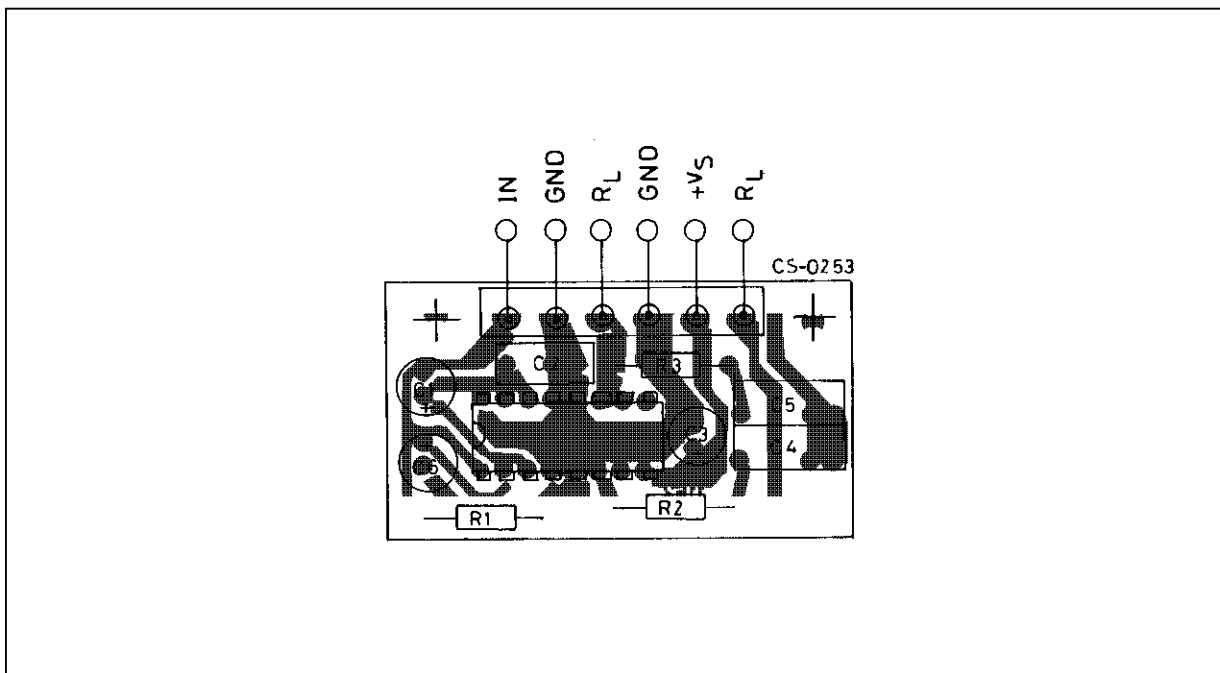

Figure 4: P.C. Board and Component Layout of the Circuit of Figure 3. (1:1 scale)



TDA2824

Figure 3 : Output Power vs. Supply Voltage (Stereo).

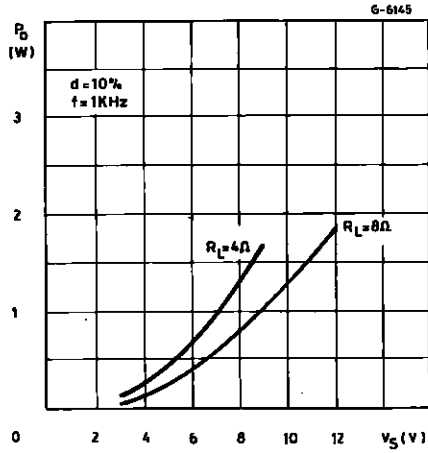

Figure 4 : Output Power vs. Supply Voltage (Bridge).

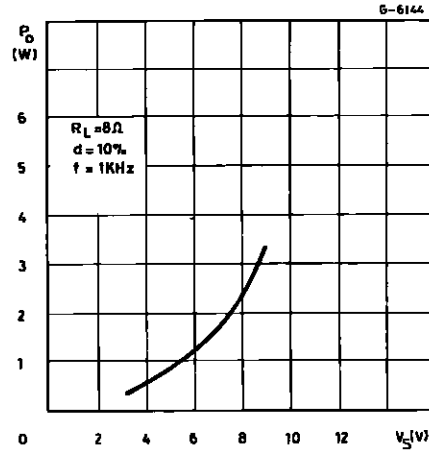

Figure 5 : Distortion vs. Output Power (Bridge).

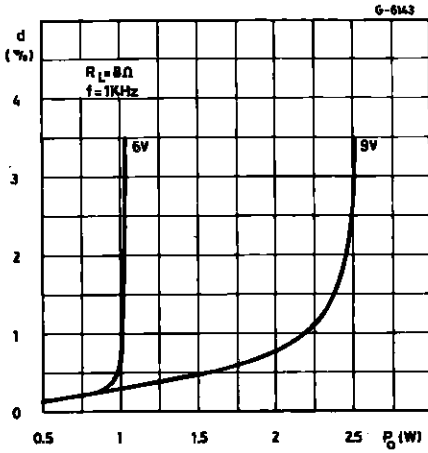

Figure 6 : Distortion vs. Output Power (Bridge).

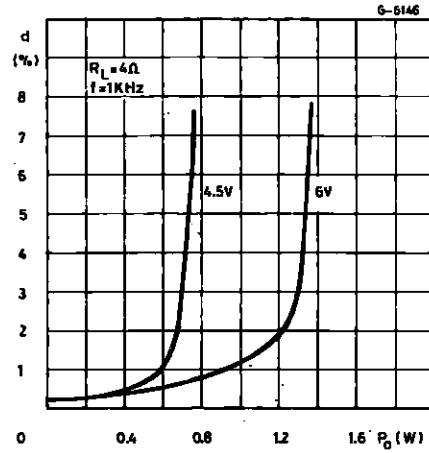

Figure 7 : Supply Voltage Rejection vs. Frequency (Stereo)

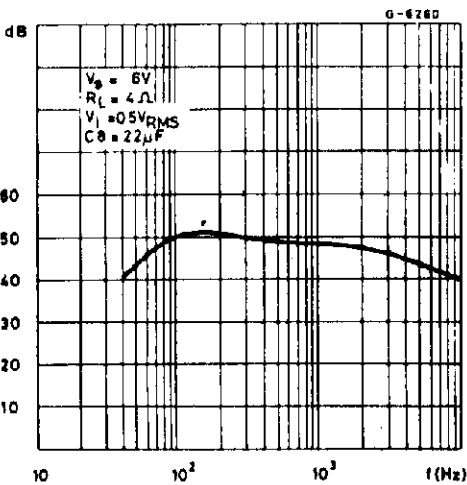

Figure 8 : Quiescent Current vs. Supply Voltage.

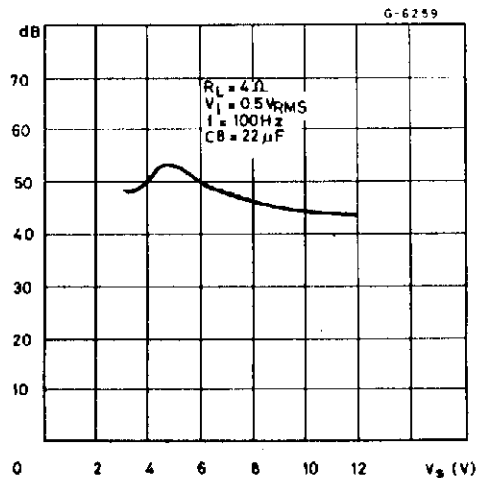

Figure 9 : Quiescent Current vs. Supply Voltage.

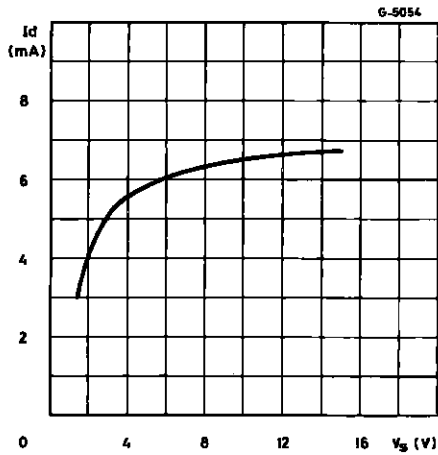

Figure 10 : Total Power Dissipation vs. Output Power (Stereo).

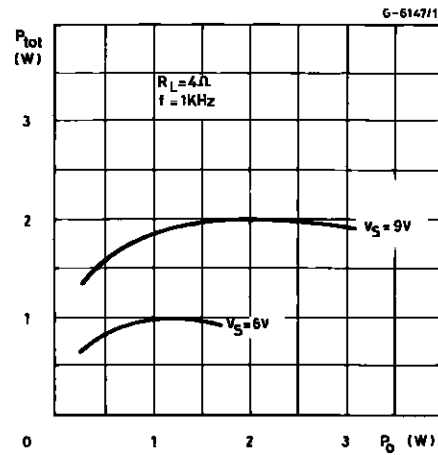

Figure 11 : Total Power Dissipation vs. Output Power (Bridge).

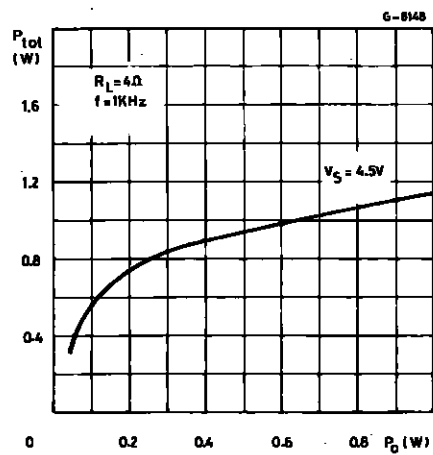
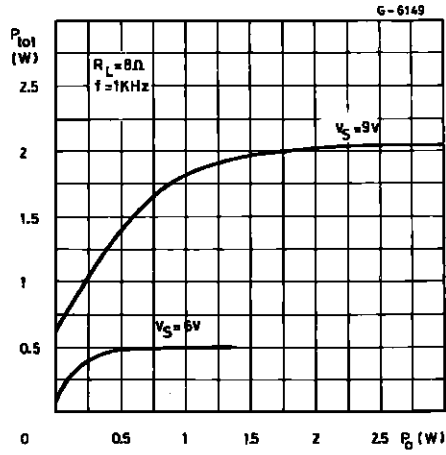

Figure 12 : Total Power Dissipation vs. Output Power (Bridge).



TDA2824

MOUNTING INSTRUCTION

The $R_{thj-amb}$ of the TDA2824 can be reduced by soldering the GND pins to a suitable copper area of the printed circuit board (Figure 13) or to an external heatsink (Figure 14).

The diagram of Figure 15 shows the maximum dissippable power P_{tot} and the $R_{thj-amb}$ as a function of the side "d" of two equal square copper areas having a thickness of $35\ \mu$ (1.4 mils).

Figure 13 : Example of P.C. Board Copper Area which is used as Heatsink.

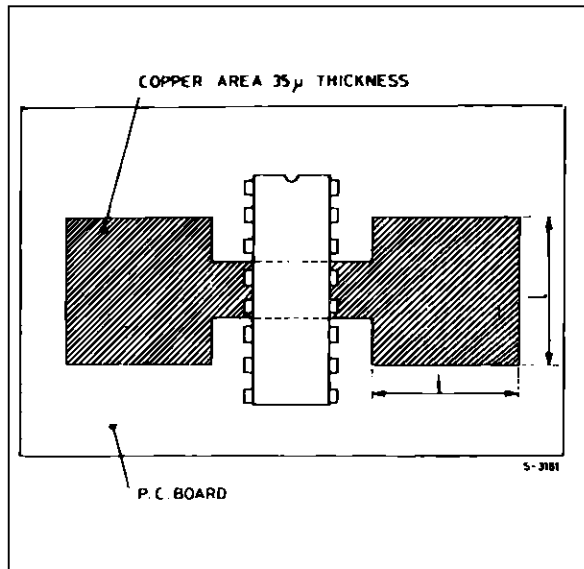
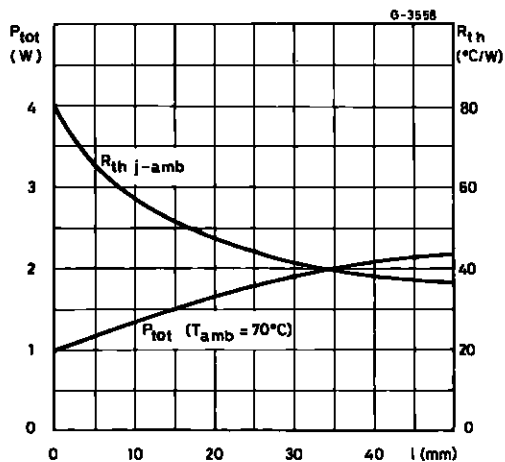

Figure 15 : Maximum Dissippable Power and Junction to Ambient Thermal Resistance vs. Side "d".



During soldering the pins temperature must not exceed $260\ ^{\circ}C$ and the soldering time must not be longer than 12 seconds.

The external heatsink or printed circuit copper area must be connected to electrical ground.

Figure 14 : External Heatsink Mounting Example.

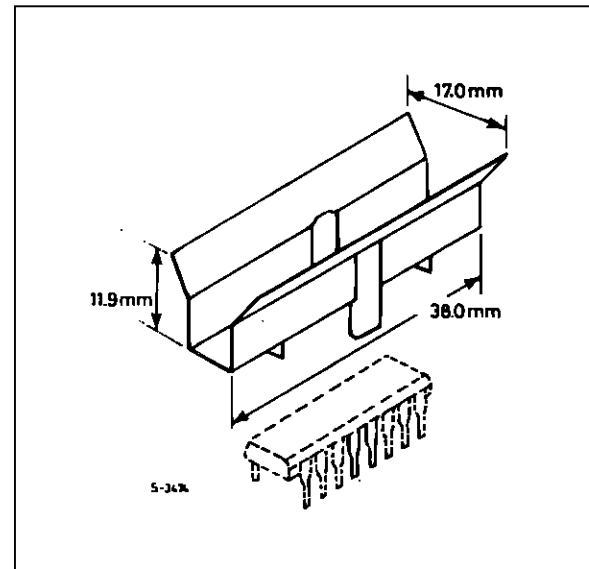
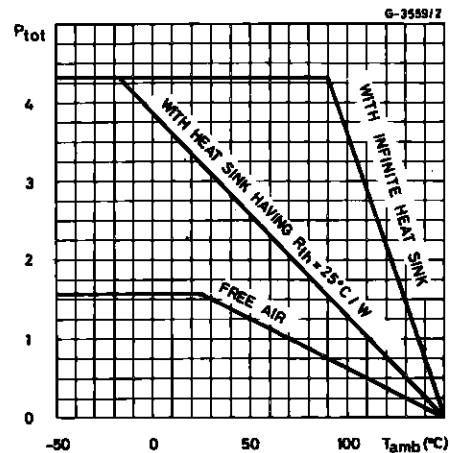
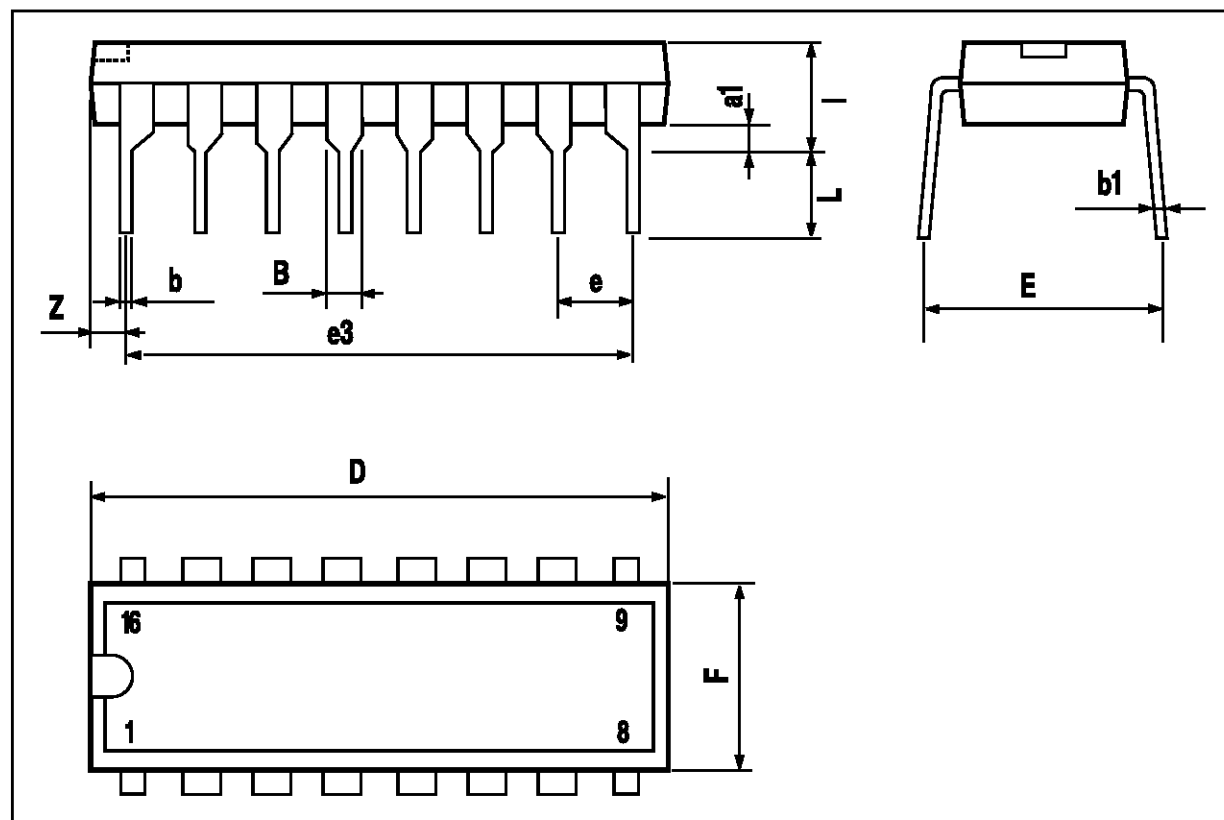

Figure 16 : Maximum Allowable Power Dissipation vs. Ambient Temperature.



POWERDIP 12+2+2 PACKAGE MECHANICAL DATA

DIM.	mm			inch		
	MIN.	TYP.	MAX.	MIN.	TYP.	MAX.
a1	0.51			0.020		
B	0.85		1.40	0.033		0.055
b		0.50			0.020	
b1	0.38		0.50	0.015		0.020
D			20.0			0.787
E		8.80			0.346	
e		2.54			0.100	
e3		17.78			0.700	
F			7.10			0.280
l			5.10			0.201
L		3.30			0.130	
Z			1.27			0.050



TDA2824

Information furnished is believed to be accurate and reliable. However, SGS-THOMSON Microelectronics assumes no responsibility for the consequences of use of such information nor for any infringement of patents or other rights of third parties which may result from its use. No license is granted by implication or otherwise under any patent or patent rights of SGS-THOMSON Microelectronics. Specifications mentioned in this publication are subject to change without notice. This publication supersedes and replaces all information previously supplied. SGS-THOMSON Microelectronics products are not authorized for use as critical components in life support devices or systems without express written approval of SGS-THOMSON Microelectronics.

© 1995 SGS-THOMSON Microelectronics - All Rights Reserved

SGS-THOMSON Microelectronics GROUP OF COMPANIES

Australia - Brazil - France - Germany - Hong Kong - Italy - Japan - Korea - Malaysia - Malta - Morocco - The Netherlands - Singapore - Spain - Sweden - Switzerland - Taiwan - Thailand - United Kingdom - U.S.A.