

**INTEGRATED CIRCUITS**

# DATA SHEET

## **TDA4800**

### Vertical deflection circuit for monitor applications

Product specification  
Supersedes data of February 1992  
File under Integrated Circuits, IC02

1997 Mar 27

## Vertical deflection circuit for monitor applications

# TDA4800

### FEATURES

- Fully integrated, few external components
- RC oscillator with wide sync range of 1 : 3 (e.g. 50 to 150 Hz)
- Synchronization by positive or negative going sync pulse
- Blanking pulse duration is determined externally
- Dual frequency criterion for automatic amplitude switch-over (e.g. 50 to 60 Hz)
- Guard circuit for screen protection
- Sawtooth generator with buffer stage supplied by external voltage
- Preamplifier
- Power output stage with thermal and SOAR protection
- Flyback generator
- Internal voltage stabilizer.

### GENERAL DESCRIPTION

The TDA4800 is an integrated circuit for vertical deflection primarily in monitors (and TV receivers). The complete circuit consists of 11 main functional blocks as shown in Fig.1.

### QUICK REFERENCE DATA

SYMBOL	PARAMETER	CONDITIONS	MIN.	TYP.	MAX.	UNIT
$V_{P1}$	supply voltage (pin 6)		10	–	30	V
$V_{P2}$	supply voltage (pin 10)		10	–	45	V
$I_P$	supply current (pins 6 and 10)	note 1	–	215	–	mA
$I_{7(p-p)}$	output current (peak-to-peak value)		–	–	2.6	A
$f_{sync}$	picture frequency	notes 1 and 2	–	–	135	Hz
$V_3$	positive sync input pulse		1.0	–	6.0	V
$V_3$	negative sync input pulse		–0.5	–	–0.7	V
$T_{amb}$	operating ambient temperature	note 3	–20	–	+70	°C

### Notes

1. Measured in Fig.4.
2.  $f_o = 45$  Hz ( $f_{sync(max)} = 3f_o$ ).
3.  $P_{tot} = 3.6$  W for  $R_{th(j-a)} = 20$  K/W.

### ORDERING INFORMATION

TYPE NUMBER	PACKAGE		
	NAME	DESCRIPTION	VERSION
TDA4800	DBS13P	plastic DIL-bent-SIL power package; 13 leads (lead length 12 mm)	SOT141-6

# Vertical deflection circuit for monitor applications

TDA4800

## BLOCK DIAGRAM

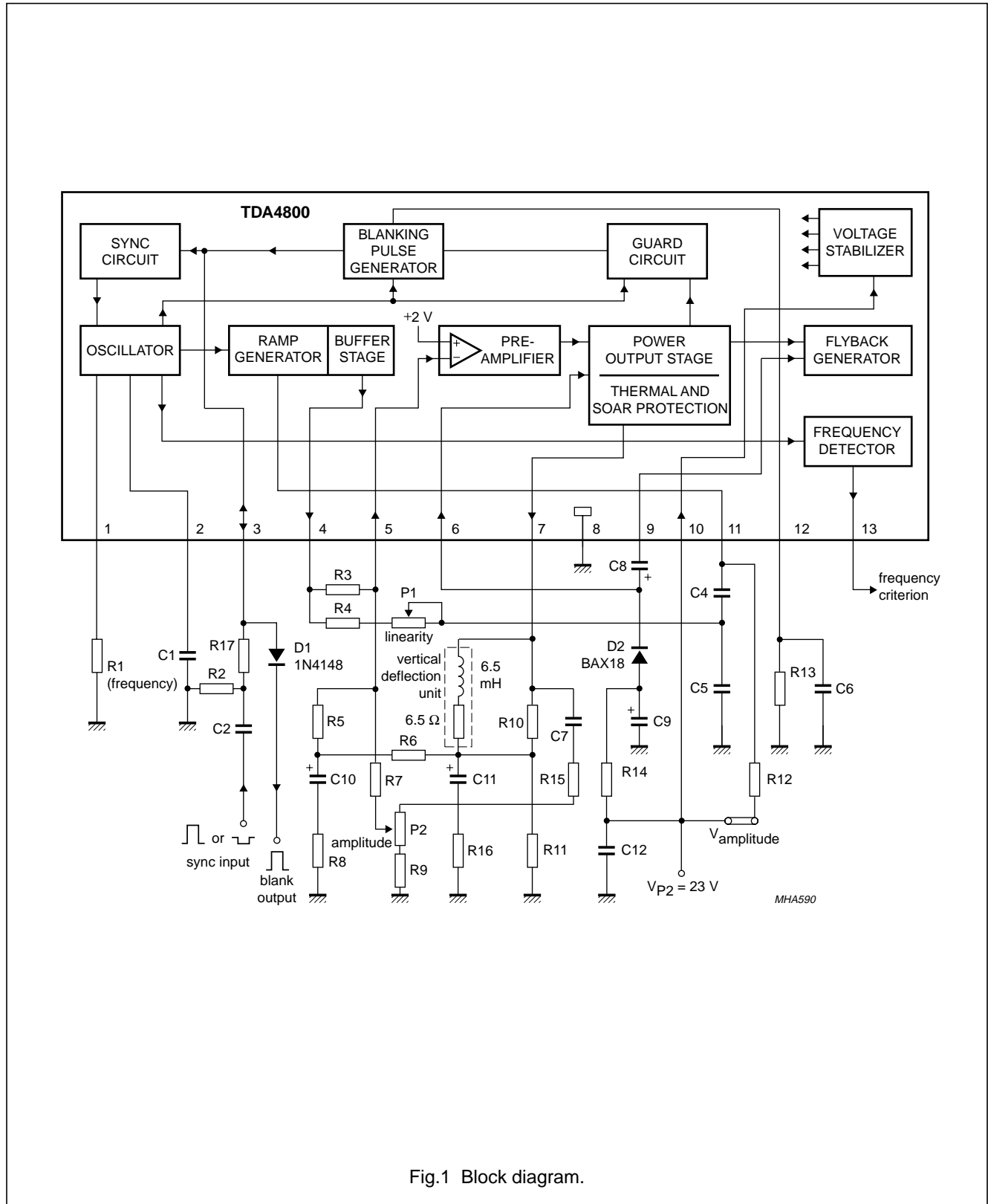

Fig.1 Block diagram.

# Vertical deflection circuit for monitor applications

## TDA4800

### PINNING

SYMBOL	PIN	DESCRIPTION
OSC <sub>R</sub>	1	oscillator resistor
OSC <sub>C</sub>	2	oscillator capacitor
SYB <sub>O</sub>	3	sync input; blanking pulse output
S <sub>OUT</sub>	4	sawtooth output
PRE <sub>I</sub>	5	preamplifier input
V <sub>P1</sub>	6	supply voltage 1
OUTP	7	deflection output
GND	8	ground
C <sub>FLY</sub>	9	pin for the flyback generator capacitor
V <sub>P2</sub>	10	supply voltage 2
S <sub>GEN</sub>	11	sawtooth generator
BP <sub>DU</sub>	12	blanking pulse duration
FRQ <sub>C</sub>	13	frequency criterion

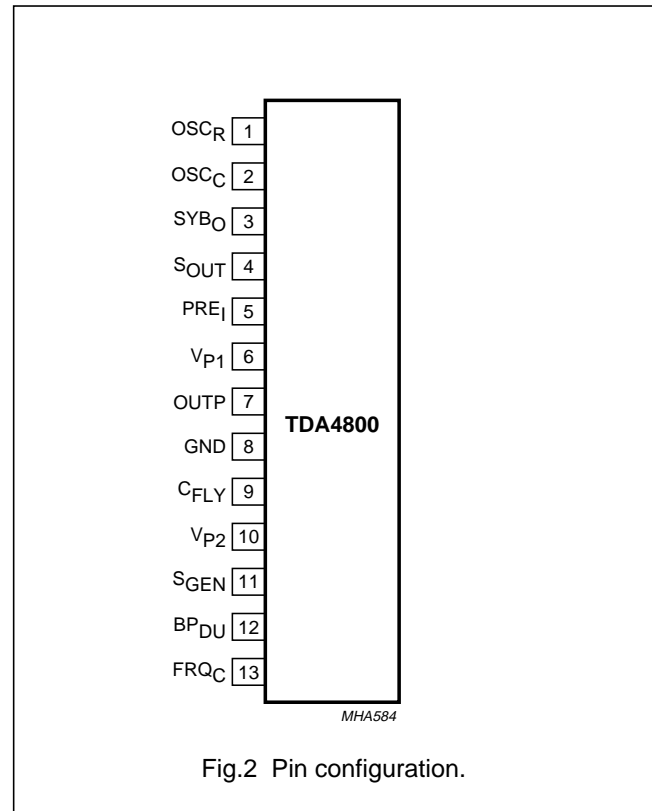

## Vertical deflection circuit for monitor applications

TDA4800

### FUNCTIONAL DESCRIPTION

The complete circuit consists of the following functional blocks as shown in Fig.1:

1. Oscillator
2. Synchronization circuit
3. Blanking pulse generator
4. Frequency detector and storage
5. Ramp generator
6. Buffer stage
7. Preamplifier
8. Power output stage
9. Flyback generator
10. Guard circuit
11. Voltage stabilizer.

#### Oscillator (pins 1 and 2)

The oscillator is an RC-oscillator with a threshold value switch, which ensures very good frequency stability.

The upper and lower threshold voltages are defined by an internal voltage divider.

An external capacitor C1 at pin 2 is charged by a constant current source. When the scan voltage of C1 reaches the upper threshold voltage, oscillator flyback starts. Capacitor C1 discharges via an internal resistor and transistor until the lower threshold is reached.

The constant charge current and free-running frequency  $f_o$  are adjusted by an external resistor R1 at pin 1:

$$f_o = \frac{1}{K \times R1 \times C1} \quad \text{with } K = 0.68.$$

#### Synchronization circuit (pin 3)

A positive- or negative-going pulse fed to pin 3 synchronizes the oscillator by lowering the upper threshold voltage. The synchronizing range is  $f_o$  to  $3f_o$ . For example:  $f_o = 50 \text{ Hz} \rightarrow f_{\text{sync(max)}} = 150 \text{ Hz}$ .

#### Blanking pulse generator (pin 3)

Also at pin 3 a blanking pulse is available. Diode D1 separates the synchronization pulse from the blanking pulse. During scanning, the external capacitor C6 at pin 12 is charged to an internal stabilized voltage  $V_{\text{stab2}}$ . The blanking pulse starts with the beginning of oscillator flyback; then capacitor C6 discharges via the external resistor R13 at pin 12. The blanking pulse stops when the capacitor voltage is  $\frac{1}{2}V_{\text{stab2}}$ .

The blanking pulse duration is determined by the values of external components R13 and C6 at pin 12:

$$t_{bl} = R13 \times C6 \times \ln 2.$$

#### Frequency detector with storage (pin 13)

At the end of the scanning period a frequency detector detects the oscillator frequency (see "Note" below).

When this frequency is above the threshold a flip-flop is set to store this information. The output is an open collector output.

#### NOTE

Frequency detector change-over at pin 13 from low (= low frequency) to high (= high frequency) is determined by  $f_o$ :  $f_{\text{threshold}} = 1.23 \times f_o$ .

#### Ramp generator (pin 11)

The ramp generator consists of two external series capacitors C4 and C5, external charge resistor R12 (connected to pin 11), and an internal differential amplifier which is synchronously switched by the oscillator.

External capacitors C4 and C5 at pin 11 are charged by the charging current via the external charge resistor R12 until oscillator flyback starts. C4 and C5 are then discharged via pin 11 by an internal resistor and transistor. This generates a positive-going ramp voltage.

#### Buffer stage (pin 4)

The buffer stage consists of two emitter followers. The ramp voltage is fed via the buffer stage and is available at pin 4 with a low ohmic output impedance. With R4 and P1 it generates a ramp function, which, together with the feedback network of the deflection yoke, gives a high degree of linearity at the picture tube. The linearity can be adjusted by P1.

#### Preamplifier (pin 5)

The preamplifier is a differential amplifier. The non-inverting input is fixed at about 2 V by an internal voltage divider. The inverting input at pin 5 is connected to the ramp voltage via R3 and feedback network P2, R5 to R11, R15, R16, C7, C10 and C11.

#### Power output stage (pin 7)

The power output stage is an amplifier with a quasi-complementary class-B output. The output is connected to pin 7.

The power stage includes SOAR and thermal protection.

# Vertical deflection circuit for monitor applications

TDA4800

### Flyback generator (pin 9)

The flyback generator has an external capacitor C8 at pin 9. During scanning, the internal circuit switches pin 9 almost to ground; thereby C8 is charged by the supply voltage via external components R14 and D2.

During the flyback time pin 9 is switched almost to the supply voltage, so that the supply voltage for the power output stage (pin 6) is nearly doubled. This high flyback voltage ensures a very short flyback time.

### Guard circuit (pin 3)

When the vertical deflection current is absent (e.g. short-circuited, or open-circuited of the yoke) the guard circuit changes the blanking pulse at pin 3 into a DC signal which blanks the beam current to protect the screen.

Also an oscillator defect (C1 short-circuited or R1 disconnected from pin 1) switches on the guard circuit.

### Voltage stabilizer

The voltage stabilizer circuit provides a stable operating voltage of about 7.5 V for several internal circuits of the TDA4800.

### INTERNAL CIRCUITRY

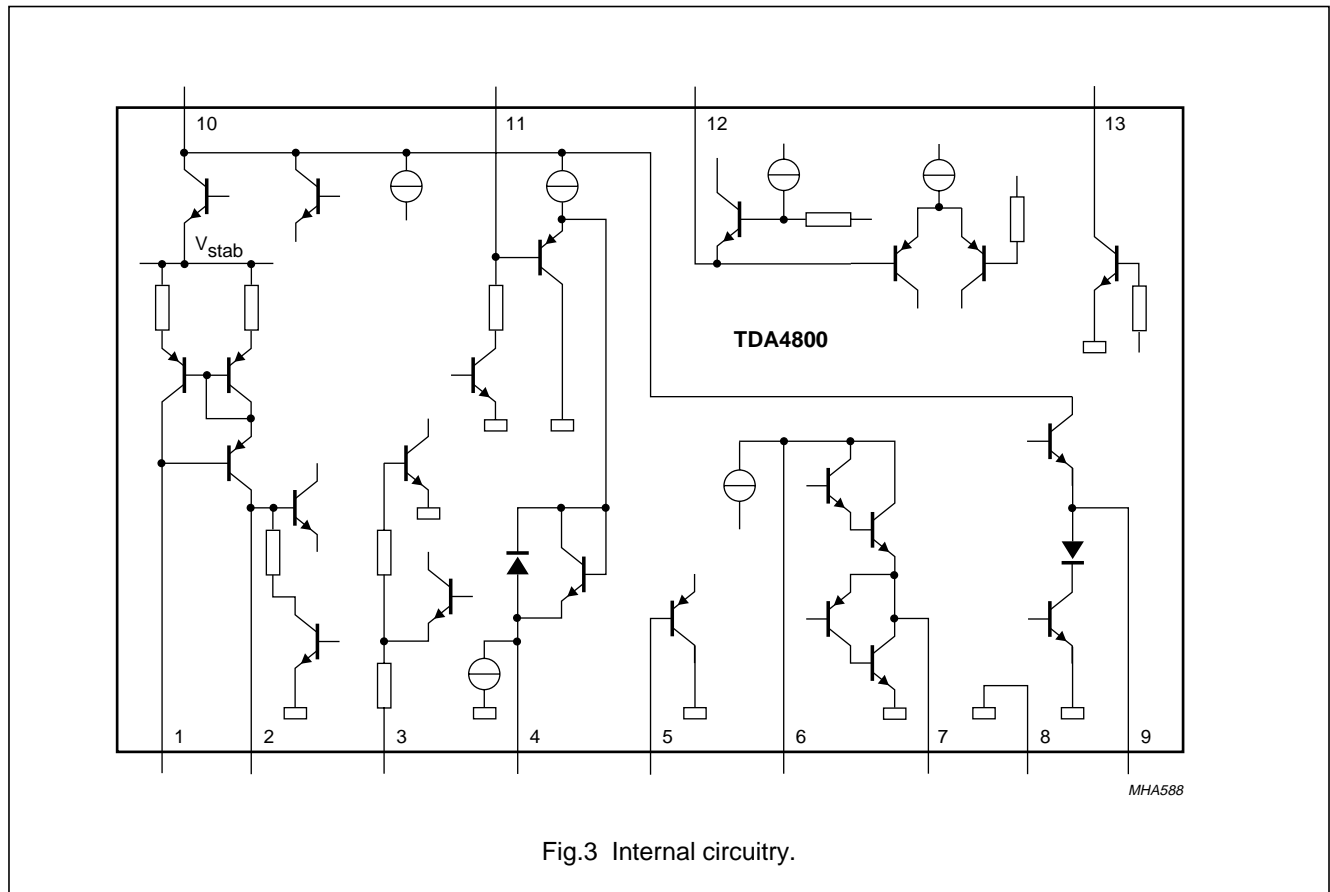

Fig.3 Internal circuitry.

# Vertical deflection circuit for monitor applications

TDA4800

## LIMITING VALUES

In accordance with the Absolute Maximum Rating System (IEC 134).

SYMBOL	PARAMETER	CONDITIONS	MIN.	MAX.	UNIT
V <sub>2</sub>	voltages		0	6	V
V <sub>11</sub>			0	24	V
V <sub>12</sub>			0	6	V
V <sub>13</sub>			0	50	V
V <sub>10</sub>	supply voltages (V <sub>P</sub> )		0	50	V
V <sub>9</sub>			0	50	V
V <sub>7</sub>			0	60	V
V <sub>6</sub>			0	60	V
V <sub>5</sub>			0	6	V
V <sub>4</sub>			0	24	V
V <sub>3</sub>			-0.7	+6	V
I <sub>1</sub>			currents		0
I <sub>3</sub>	+3	-10			mA
I <sub>4</sub>	0	-5			mA
I <sub>6, I7, I8</sub>	note 1				
I <sub>9</sub>	-1.5	+1.5			A
I <sub>11</sub>	-0.1	+30			mA
T <sub>stg</sub>	storage temperature		-25	+150	°C
T <sub>amb</sub>	operating ambient temperature	note 2	-20	+70	°C
T <sub>j</sub>	junction temperature	note 3	-	150	°C
P <sub>tot</sub>	total power dissipation	note 2	-	-	W
V <sub>ESD</sub>	ESD sensitivity	note 4	-2000	+2000	V

## Notes

- I<sub>6</sub>, I<sub>7</sub> and I<sub>8</sub> are limited by SOAR protection circuit that ensures that short-circuiting between the output pin 7 and supply voltage or ground does not destroy the output stage. A short-circuit may be soldered into the printed-circuit board or may sometimes (non-periodically) occur in the applied circuit.
- The maximum value for the operating ambient temperature range and the power dissipation depends on the heatsink.
- Internally limited by thermal protection: switching temperature point at T<sub>j</sub> = 150 ± 8 °C.
- Human body model: 1.5 kΩ, 100 pF, 5 pulses.

## THERMAL CHARACTERISTICS

SYMBOL	PARAMETER	VALUE	UNIT
R <sub>th(j-a)</sub>	thermal resistance from junction to ambient	20	K/W
R <sub>th(j-mb)</sub>	thermal resistance from junction to mounting base	5	K/W

# Vertical deflection circuit for monitor applications

TDA4800

## CHARACTERISTICS

All voltages are measured to GND (ground; pin 8);  $T_{amb} = 25\text{ °C}$ ;  $V_P = 23\text{ V}$ ; unless otherwise specified.

SYMBOL	PARAMETER	CONDITIONS	MIN.	TYP.	MAX.	UNIT
$V_{P1}$	supply voltage (pin 6)		10	–	30	V
$V_{P2}$	supply voltage (pin 10)		10	–	45	V
$I_{10}$	supply current	$V_{10} = 25\text{ V}$ ; $V_5 = 3\text{ V}$ without load	–	12	–	mA
$I_6$	supply current	$V_6 = 25\text{ V}$ ; $V_5 = 1\text{ V}$ without load	–	20	–	mA
$I_6$	supply current	$V_6 = 25\text{ V}$ ; $V_5 = 3\text{ V}$ without load	–	5	–	mA
$V_{7(\min)}$	minimum output voltage	$I_7 = 1\text{ A}$	–	1.4	1.65	V
$V_{7(\max)}$	maximum output voltage	$I_7 = -1\text{ A}$	$V_6 - 2.3$	$V_6 - 2.0$	–	V
$V_9$	output voltage during flyback	$I_9 = -1\text{ A}$	–	$V_{10} - 2.2$	–	V
$I_7$	output current		–	–	$\pm 1.3$	A
$I_9$	output current		–	–	$\pm 1.3$	A
$I_5$	preamplifier input current		–	-0.1	–	$\mu\text{A}$
$V_1$	stabilized voltage		6.1	6.8	7.3	V
$V_3$	blanking pulse output voltage		–	5.7	–	V
$R_3$	blanking pulse output resistance		–	300	–	$\Omega$
$I_3$	blanking pulse output current		0	–	-3	mA
$t_{bl}$	blanking pulse duration	$R = 100\text{ k}\Omega$ ; $C = 10\text{ nF}$ (pin 12)	640	680	730	$\mu\text{s}$
$V_{11}$	output voltage ramp generator		0.3	–	20	V
$I_{11}$	output current ramp generator		-2	–	$15 \times 10^3$	$\mu\text{A}$
$V_{13}$	output voltage frequency detector	lower frequency $I_{13} = 1\text{ mA}$	–	–	1.0	V
$I_{13}$	leakage current frequency detector	higher frequency $V_{13} = 50\text{ V}$	–	–	1.0	$\mu\text{A}$
$V_4$	output voltage buffer stage		0	–	20	V
$I_4$	output current buffer stage		–	–	-4.0	mA
$V_3$	synchronizing input voltage	positive sync	1.0	–	6.0	V
$V_3$	synchronizing input voltage	negative sync	-0.5	–	-0.7	V
	tolerance of free running oscillator	without sync	-3.0	–	+3.0	%
$\frac{\Delta f}{f} \times \frac{1}{\Delta T_{mb}}$	oscillator temperature dependency	$T_{mb} = 20\text{ to }100\text{ °C}$	–	$10^{-4}$	–	$\text{K}^{-1}$
$\frac{\Delta f}{f} \times \frac{1}{\Delta V_P}$	oscillator voltage dependency	$V_P = 10\text{ to }30\text{ V}$	–	$4 \times 10^{-4}$	–	$\text{K}^{-1}$
$\frac{f_o}{f_{sync}}$	synchronizing ratio		1 : 2.9	1 : 3	–	



# Vertical deflection circuit for monitor applications

TDA4800

## TEST AND APPLICATION INFORMATION

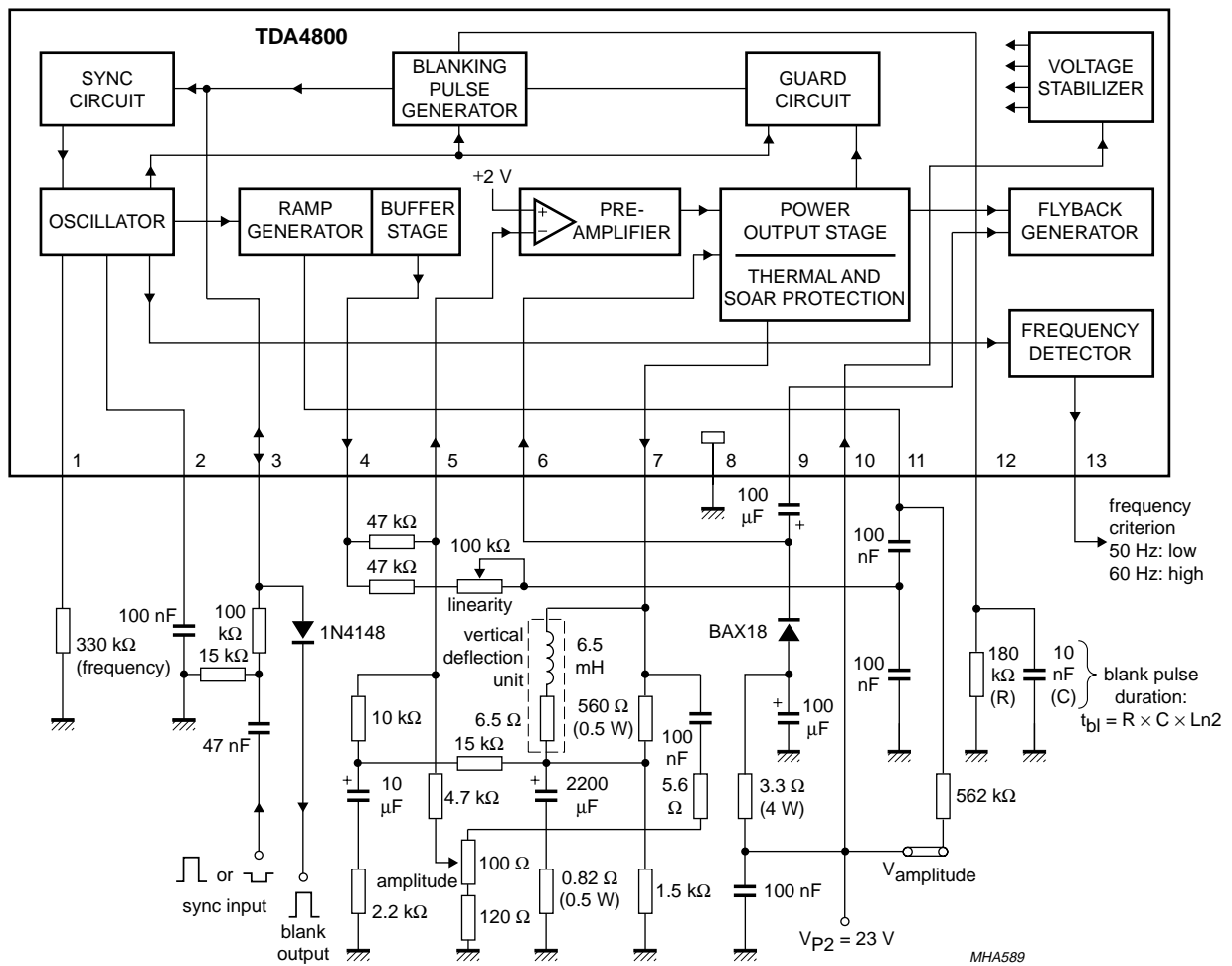

Fig.4 Test and application circuit.

## Vertical deflection circuit for monitor applications

TDA4800

### TDA4800 in the test and application circuit (see Fig.4)

SYMBOL	PARAMETER	CONDITIONS	TYP.	UNIT
$V_{P2}$	supply voltage		23	V
$I_P$	supply current		215	mA
$V_7$	DC output voltage		11.8	V
$V_{7M}$	peak output voltage		45	V
$I_7$	output current		0.8	A
$I_{Y(p-p)}$	vertical deflection current (peak-to-peak value)		1.5	A
$t_{fb}$	flyback time		0.3	ms
$t_{bl}$	blanking pulse duration		1.25	ms
$P_{tot}$	total power dissipation		3.3	W
$f_o$	free running oscillator frequency	without sync	45	Hz

# Vertical deflection circuit for monitor applications

TDA4800

## PACKAGE OUTLINE

DBS13P: plastic DIL-bent-SIL power package; 13 leads (lead length 12 mm)

SOT141-6

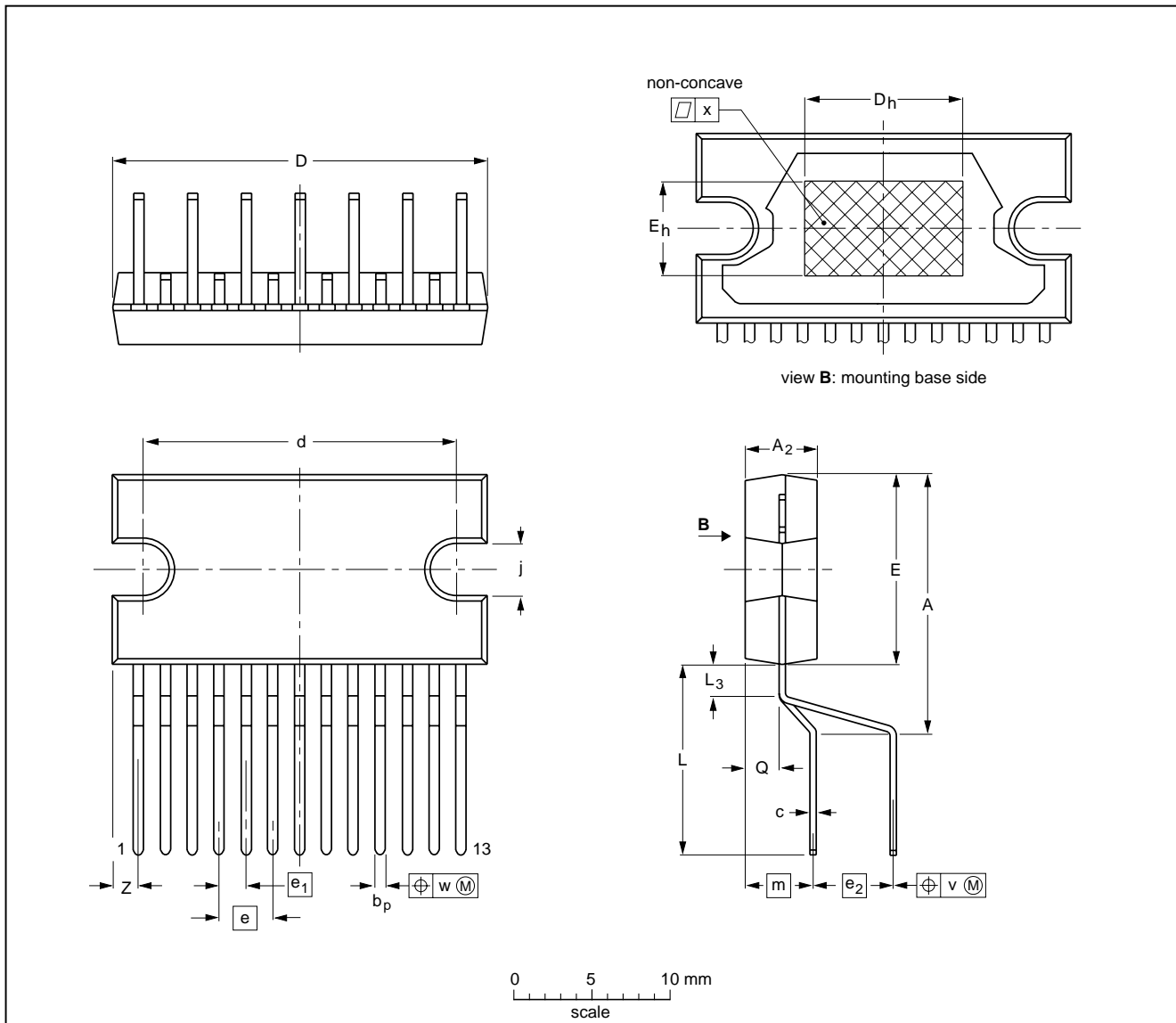

**DIMENSIONS (mm are the original dimensions)**

UNIT	A	A <sub>2</sub>	b <sub>p</sub>	c	D <sup>(1)</sup>	d	D <sub>h</sub>	E <sup>(1)</sup>	e	e <sub>1</sub>	e <sub>2</sub>	E <sub>h</sub>	j	L	L <sub>3</sub>	m	Q	v	w	x	Z <sup>(1)</sup>
mm	17.0 15.5	4.6 4.2	0.75 0.60	0.48 0.38	24.0 23.6	20.0 19.6	10	12.2 11.8	3.4	1.7	5.08	6	3.4 3.1	12.4 11.0	2.4 1.6	4.3	2.1 1.8	0.8	0.25	0.03	2.00 1.45

**Note**

1. Plastic or metal protrusions of 0.25 mm maximum per side are not included.

OUTLINE VERSION	REFERENCES				EUROPEAN PROJECTION	ISSUE DATE
	IEC	JEDEC	EIAJ			
SOT141-6						92-11-17 95-03-11

# Vertical deflection circuit for monitor applications

TDA4800

## MOUNTING INSTRUCTIONS FOR 13-LEAD DBS13P POWER PACKAGE

The rise in temperature caused by power dissipation in the circuit is reduced by adding a heatsink with a sufficiently low thermal resistance:  
 $R_{th(mb-h)} + R_{th(h-a)} = R_{th(mb-a)}$   
 (e.g. the heatsink of Fig.5). It is possible to attach the package to the heatsink by screws (Fig.6) or by a compression spring (Fig.7). A layer of silicon grease between the heatsink and the mounting base optimizes thermal contact.

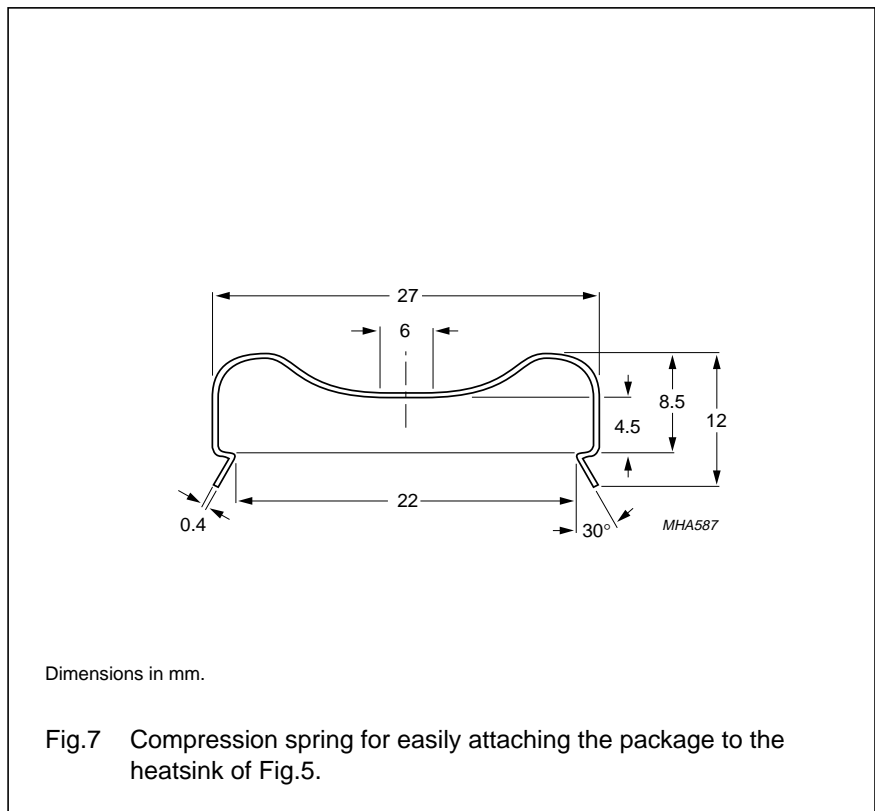
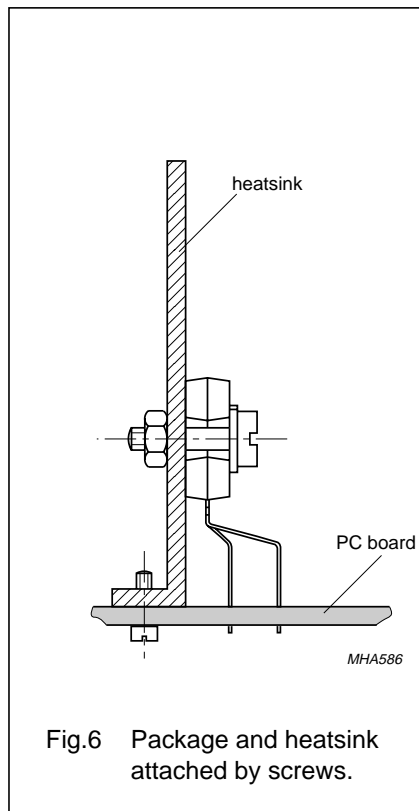
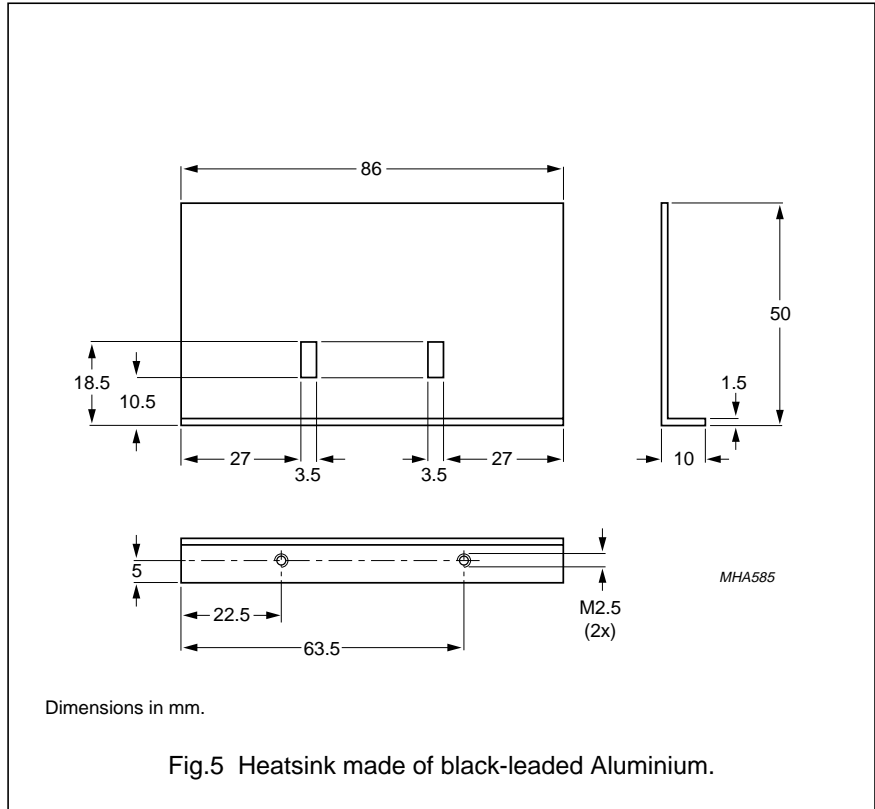

## Vertical deflection circuit for monitor applications

TDA4800

### SOLDERING

#### Introduction

There is no soldering method that is ideal for all IC packages. Wave soldering is often preferred when through-hole and surface mounted components are mixed on one printed-circuit board. However, wave soldering is not always suitable for surface mounted ICs, or for printed-circuits with high population densities. In these situations reflow soldering is often used.

This text gives a very brief insight to a complex technology. A more in-depth account of soldering ICs can be found in our *"IC Package Databook"* (order code 9398 652 90011).

#### Soldering by dipping or by wave

The maximum permissible temperature of the solder is 260 °C; solder at this temperature must not be in contact with the joint for more than 5 seconds. The total contact time of successive solder waves must not exceed 5 seconds.

The device may be mounted up to the seating plane, but the temperature of the plastic body must not exceed the specified maximum storage temperature ( $T_{stg\ max}$ ). If the printed-circuit board has been pre-heated, forced cooling may be necessary immediately after soldering to keep the temperature within the permissible limit.

#### Repairing soldered joints

Apply a low voltage soldering iron (less than 24 V) to the lead(s) of the package, below the seating plane or not more than 2 mm above it. If the temperature of the soldering iron bit is less than 300 °C it may remain in contact for up to 10 seconds. If the bit temperature is between 300 and 400 °C, contact may be up to 5 seconds.

### DEFINITIONS

Data sheet status	
Objective specification	This data sheet contains target or goal specifications for product development.
Preliminary specification	This data sheet contains preliminary data; supplementary data may be published later.
Product specification	This data sheet contains final product specifications.
Limiting values	
Limiting values given are in accordance with the Absolute Maximum Rating System (IEC 134). Stress above one or more of the limiting values may cause permanent damage to the device. These are stress ratings only and operation of the device at these or at any other conditions above those given in the Characteristics sections of the specification is not implied. Exposure to limiting values for extended periods may affect device reliability.	
Application information	
Where application information is given, it is advisory and does not form part of the specification.	

### LIFE SUPPORT APPLICATIONS

These products are not designed for use in life support appliances, devices, or systems where malfunction of these products can reasonably be expected to result in personal injury. Philips customers using or selling these products for use in such applications do so at their own risk and agree to fully indemnify Philips for any damages resulting from such improper use or sale.

Vertical deflection circuit for monitor  
applications

TDA4800

---

**NOTES**

Vertical deflection circuit for monitor  
applications

TDA4800

---

**NOTES**

# Philips Semiconductors – a worldwide company

**Argentina:** see South America

**Australia:** 34 Waterloo Road, NORTH RYDE, NSW 2113,  
Tel. +61 2 9805 4455, Fax. +61 2 9805 4466

**Austria:** Computerstr. 6, A-1101 WIEN, P.O. Box 213,  
Tel. +43 1 60 101, Fax. +43 1 60 101 1210

**Belarus:** Hotel Minsk Business Center, Bld. 3, r. 1211, Volodarski Str. 6,  
220050 MINSK, Tel. +375 172 200 733, Fax. +375 172 200 773

**Belgium:** see The Netherlands

**Brazil:** see South America

**Bulgaria:** Philips Bulgaria Ltd., Energoproject, 15th floor,  
51 James Bourchier Blvd., 1407 SOFIA,  
Tel. +359 2 689 211, Fax. +359 2 689 102

**Canada:** PHILIPS SEMICONDUCTORS/COMPONENTS,  
Tel. +1 800 234 7381

**China/Hong Kong:** 501 Hong Kong Industrial Technology Centre,  
72 Tat Chee Avenue, Kowloon Tong, HONG KONG,  
Tel. +852 2319 7888, Fax. +852 2319 7700

**Colombia:** see South America

**Czech Republic:** see Austria

**Denmark:** Prags Boulevard 80, PB 1919, DK-2300 COPENHAGEN S,  
Tel. +45 32 88 2636, Fax. +45 31 57 1949

**Finland:** Sinikalliontie 3, FIN-02630 ESPOO,  
Tel. +358 9 615800, Fax. +358 9 61580/xxx

**France:** 4 Rue du Port-aux-Vins, BP317, 92156 SURESNES Cedex,  
Tel. +33 1 40 99 6161, Fax. +33 1 40 99 6427

**Germany:** Hammerbrookstraße 69, D-20097 HAMBURG,  
Tel. +49 40 23 53 60, Fax. +49 40 23 536 300

**Greece:** No. 15, 25th March Street, GR 17778 TAVROS/ATHENS,  
Tel. +30 1 4894 339/239, Fax. +30 1 4814 240

**Hungary:** see Austria

**India:** Philips INDIA Ltd, Shivsagar Estate, A Block, Dr. Annie Besant Rd.  
Worli, MUMBAI 400 018, Tel. +91 22 4938 541, Fax. +91 22 4938 722

**Indonesia:** see Singapore

**Ireland:** Newstead, Clonskeagh, DUBLIN 14,  
Tel. +353 1 7640 000, Fax. +353 1 7640 200

**Israel:** RAPAC Electronics, 7 Kehilat Saloniki St, TEL AVIV 61180,  
Tel. +972 3 645 0444, Fax. +972 3 649 1007

**Italy:** PHILIPS SEMICONDUCTORS, Piazza IV Novembre 3,  
20124 MILANO, Tel. +39 2 6752 2531, Fax. +39 2 6752 2557

**Japan:** Philips Bldg 13-37, Kohnan 2-chome, Minato-ku, TOKYO 108,  
Tel. +81 3 3740 5130, Fax. +81 3 3740 5077

**Korea:** Philips House, 260-199 Itaewon-dong, Yongsan-ku, SEOUL,  
Tel. +82 2 709 1412, Fax. +82 2 709 1415

**Malaysia:** No. 76 Jalan Universiti, 46200 PETALING JAYA, SELANGOR,  
Tel. +60 3 750 5214, Fax. +60 3 757 4880

**Mexico:** 5900 Gateway East, Suite 200, EL PASO, TEXAS 79905,  
Tel. +9-5 800 234 7381

**Middle East:** see Italy

**Netherlands:** Postbus 90050, 5600 PB EINDHOVEN, Bldg. VB,  
Tel. +31 40 27 82785, Fax. +31 40 27 88399

**New Zealand:** 2 Wagener Place, C.P.O. Box 1041, AUCKLAND,  
Tel. +64 9 849 4160, Fax. +64 9 849 7811

**Norway:** Box 1, Manglerud 0612, OSLO,  
Tel. +47 22 74 8000, Fax. +47 22 74 8341

**Philippines:** Philips Semiconductors Philippines Inc.,  
106 Valero St. Salcedo Village, P.O. Box 2108 MCC, MAKATI,  
Metro MANILA, Tel. +63 2 816 6380, Fax. +63 2 817 3474

**Poland:** Ul. Lukiska 10, PL 04-123 WARSZAWA,  
Tel. +48 22 612 2831, Fax. +48 22 612 2327

**Portugal:** see Spain

**Romania:** see Italy

**Russia:** Philips Russia, Ul. Usatcheva 35A, 119048 MOSCOW,  
Tel. +7 095 755 6918, Fax. +7 095 755 6919

**Singapore:** Lorong 1, Toa Payoh, SINGAPORE 1231,  
Tel. +65 350 2538, Fax. +65 251 6500

**Slovakia:** see Austria

**Slovenia:** see Italy

**South Africa:** S.A. PHILIPS Pty Ltd., 195-215 Main Road Martindale,  
2092 JOHANNESBURG, P.O. Box 7430 Johannesburg 2000,  
Tel. +27 11 470 5911, Fax. +27 11 470 5494

**South America:** Rua do Rocio 220, 5th floor, Suite 51,  
04552-903 São Paulo, SÃO PAULO - SP, Brazil,  
Tel. +55 11 821 2333, Fax. +55 11 829 1849

**Spain:** Balmes 22, 08007 BARCELONA,  
Tel. +34 3 301 6312, Fax. +34 3 301 4107

**Sweden:** Kottbygatan 7, Akalla, S-16485 STOCKHOLM,  
Tel. +46 8 632 2000, Fax. +46 8 632 2745

**Switzerland:** Allmendstrasse 140, CH-8027 ZÜRICH,  
Tel. +41 1 488 2686, Fax. +41 1 481 7730

**Taiwan:** Philips Semiconductors, 6F, No. 96, Chien Kuo N. Rd., Sec. 1,  
TAIPEI, Taiwan Tel. +886 2 2134 2870, Fax. +886 2 2134 2874

**Thailand:** PHILIPS ELECTRONICS (THAILAND) Ltd.,  
209/2 Sanpavuth-Bangna Road Prakanong, BANGKOK 10260,  
Tel. +66 2 745 4090, Fax. +66 2 398 0793

**Turkey:** Talatpasa Cad. No. 5, 80640 GÜLTEPE/ISTANBUL,  
Tel. +90 212 279 2770, Fax. +90 212 282 6707

**Ukraine:** PHILIPS UKRAINE, 4 Patrice Lumumba str., Building B, Floor 7,  
252042 KIEV, Tel. +380 44 264 2776, Fax. +380 44 268 0461

**United Kingdom:** Philips Semiconductors Ltd., 276 Bath Road, Hayes,  
MIDDLESEX UB3 5BX, Tel. +44 181 730 5000, Fax. +44 181 754 8421

**United States:** 811 East Arques Avenue, SUNNYVALE, CA 94088-3409,  
Tel. +1 800 234 7381

**Uruguay:** see South America

**Vietnam:** see Singapore

**Yugoslavia:** PHILIPS, Trg N. Pasica 5/v, 11000 BEOGRAD,  
Tel. +381 11 625 344, Fax. +381 11 635 777

**For all other countries apply to:** Philips Semiconductors, Marketing & Sales Communications,  
Building BE-p, P.O. Box 218, 5600 MD EINDHOVEN, The Netherlands, Fax. +31 40 27 24825

**Internet:** <http://www.semiconductors.philips.com>

© Philips Electronics N.V. 1997

SCA53

All rights are reserved. Reproduction in whole or in part is prohibited without the prior written consent of the copyright owner.

The information presented in this document does not form part of any quotation or contract, is believed to be accurate and reliable and may be changed without notice. No liability will be accepted by the publisher for any consequence of its use. Publication thereof does not convey nor imply any license under patent- or other industrial or intellectual property rights.

Printed in The Netherlands

547047/1200/02/pp16

Date of release: 1997 Mar 27

Document order number: 9397 750 01396

*Let's make things better.*

**Philips  
Semiconductors**



**PHILIPS**