



TDA8179FS

TV VERTICAL DEFLECTION BOOSTER

- POWER AMPLIFIER
- FLYBACK SUPPLY VOLTAGE SEPARATED
- THERMAL PROTECTION

DESCRIPTION

Designed for monitors and high performance TVs, the TDA8179FS vertical deflection booster is able to work with a flyback voltage more than the double of V_s .

The TDA8179FS operates with supplies up to 42V, flyback output up to 92V and provides up to 2App output current to drive to yoke.

The TDA8179FS is offered in HEPTAWATT package.

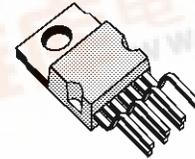

HEPTAWATT
(Plastic Package)

ORDER CODE : TDA8179FS

PIN CONNECTIONS

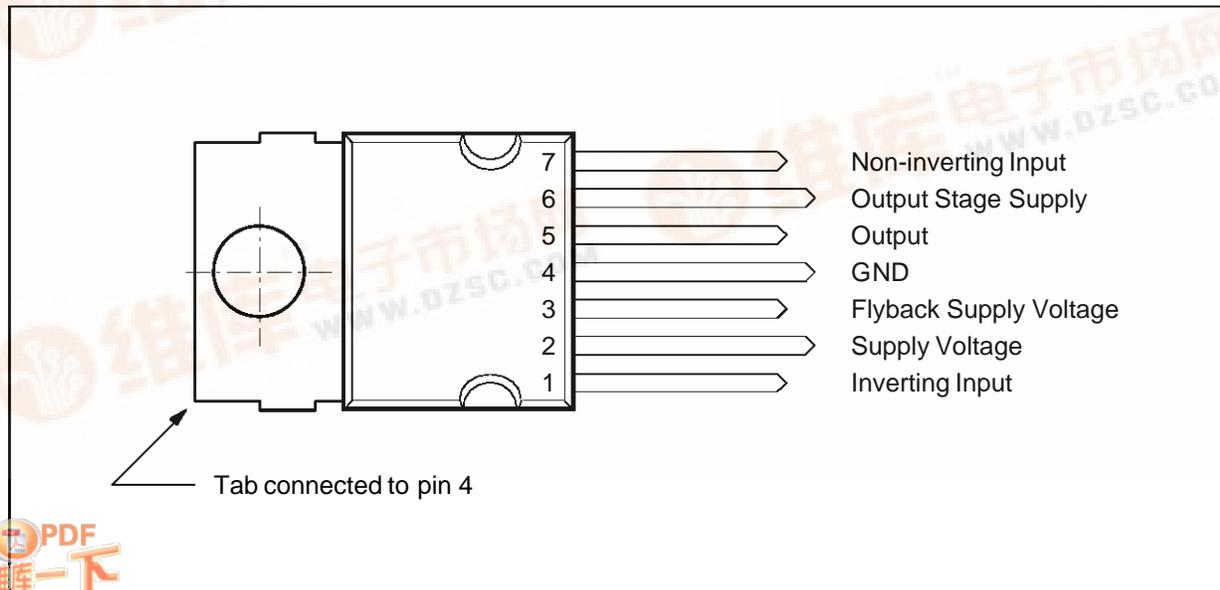

TDA8179FS

BLOCK DIAGRAM

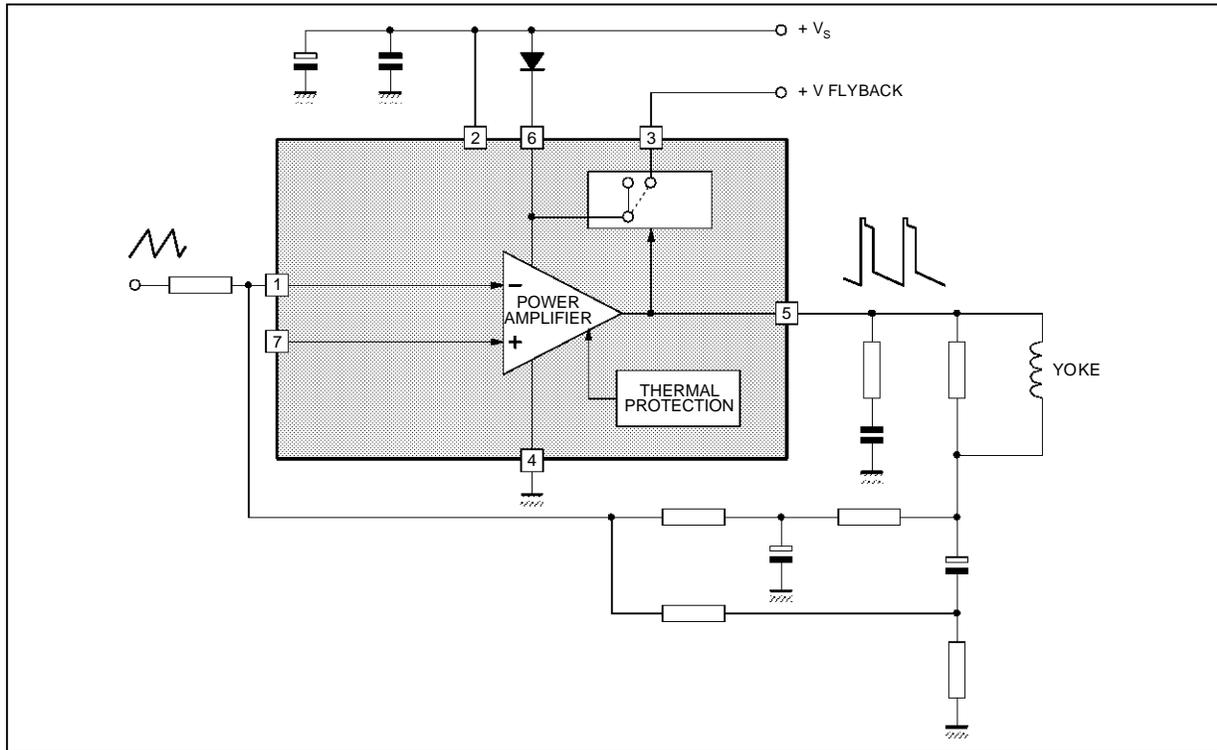

8179F-02.EPS

APPLICATION CIRCUIT

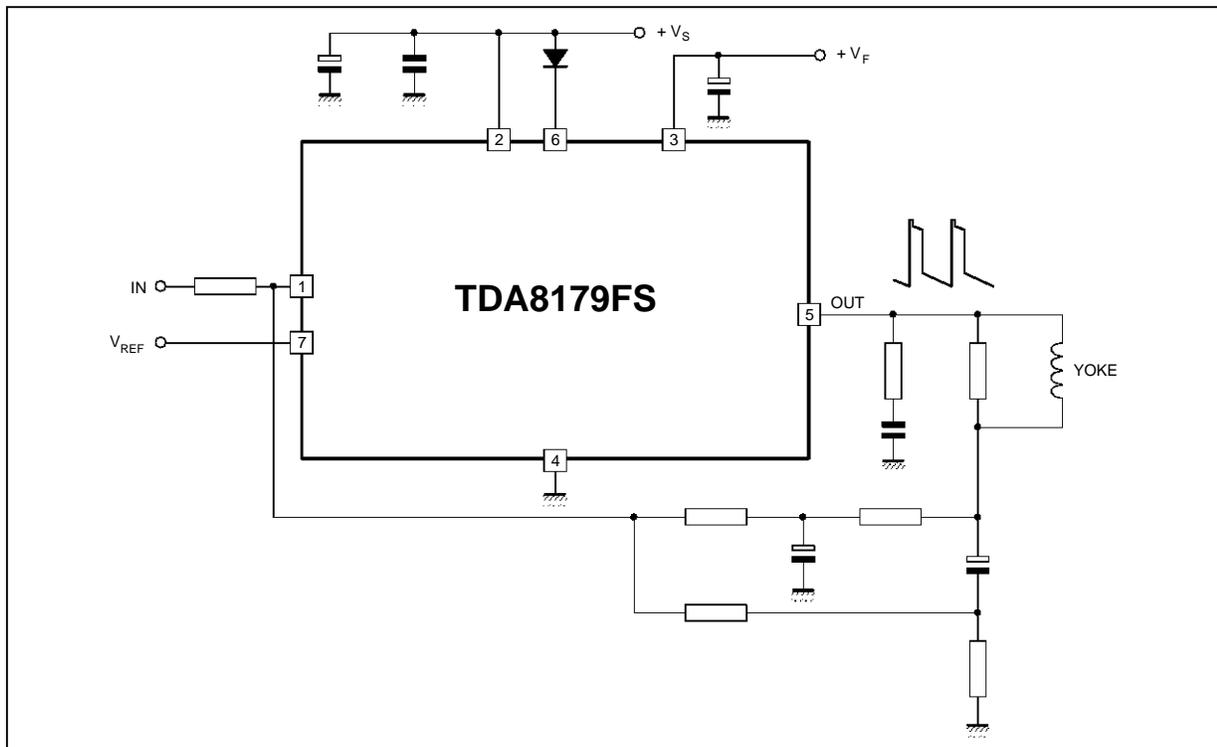

8179F-03.EPS

Note : For values see " Easy Design of Vertical Deflection Stages" (software available from our sales offices)

ABSOLUTE MAXIMUM RATINGS

Symbol	Parameter	Value	Unit
V_S	Supply Voltage (pin 2)	50	V
V_F	Flyback Supply Voltage	100	V
$V_F - V_S$	Difference between Flyback Supply Voltage and Supply Voltage	50	V
V_1, V_7	Amplifier Input Voltage	+ V_S	
I_O	Output Peak Current	2 2 1.8	A
	Non-repetitive, $t = 2\text{ms}$ $f = 50$ or 60Hz , $t \leq 10\mu\text{s}$ $f = 50$ or 60Hz , $t > 10\mu\text{s}$		
I_3	Pin 3 Peak Flyback Current at $f = 50$ or 60Hz , $t_{fly} \leq 1.5\text{ms}$	1.8	A
P_{tot}	Total Power Dissipation at $T_C = 70^\circ\text{C}$	20	W
T_{stg}	Storage Temperature	- 40, + 150	$^\circ\text{C}$
T_j	Junction Temperature	0, +150	$^\circ\text{C}$

8179F-01.TBL

THERMAL DATA

Symbol	Parameter	Value	Unit
$R_{th(j-c)}$	Junction-case Thermal Resistance	Max. 3	$^\circ\text{C}/\text{W}$

8179F-02.TBL

ELECTRICAL CHARACTERISTICS

($V_7 = 2.2\text{V}$, $V_S = 42\text{V}$, $T_A = 25^\circ\text{C}$, unless otherwise specified)
(refer to the test circuits - see Figure 1 next page)

Symbol	Parameter	Test Conditions	Min.	Typ.	Max.	Unit
V_S	Operating Supply Voltage Range		10		42	V
I_2	Pin 2 Quiescent Current	$I_3 = 0$ $I_5 = 0$		10	20	mA
I_6	Pin 6 Quiescent Current	$I_3 = 0$ $I_5 = 0$		20	40	mA
I_1	Amplifier Bias Current	$V_1 = 1\text{V}$		- 0.2	- 1	μA
V_5	Quiescent Output Voltage	$V_S = 42\text{V}$ $R_a = 3.9\text{k}\Omega$ $V_S = 35\text{V}$ $R_a = 5.6\text{k}\Omega$	23.4 17	24.2 17.8	25 18.5	V
V_{5L}	Output Saturation Voltage to GND	$I_5 = 1\text{A}$		1.2	1.5	V
V_{5H}	Output Saturation Voltage to Supply	- $I_5 = 1\text{A}$		2.2	2.6	V
V_{D5-6}	Diode Forward Voltage between Pins 5-6	$I_D = 1\text{A}$		1.5	3	V
V_{D3-6}	Diode Forward Voltage between Pins 3-6	$I_D = 1\text{A}$		1.5	3	V
R_1	Input Resistance			200		$\text{k}\Omega$
T_j	Junction Temperature for Thermal Shutdown			140		$^\circ\text{C}$

8179F-03.TBL

TDA8179FS

FIGURE 1 : DC Test Circuits

Figure 1a : Measurement of I_1 , I_2 , I_6

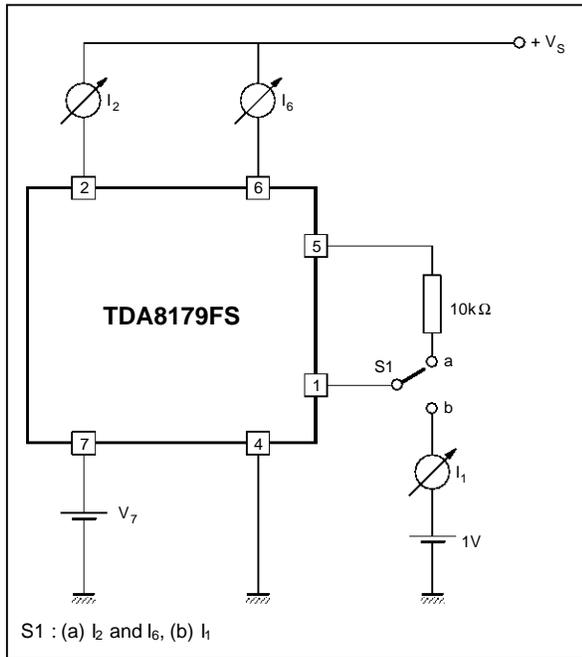

Figure 1b : Measurement of V_{5H}

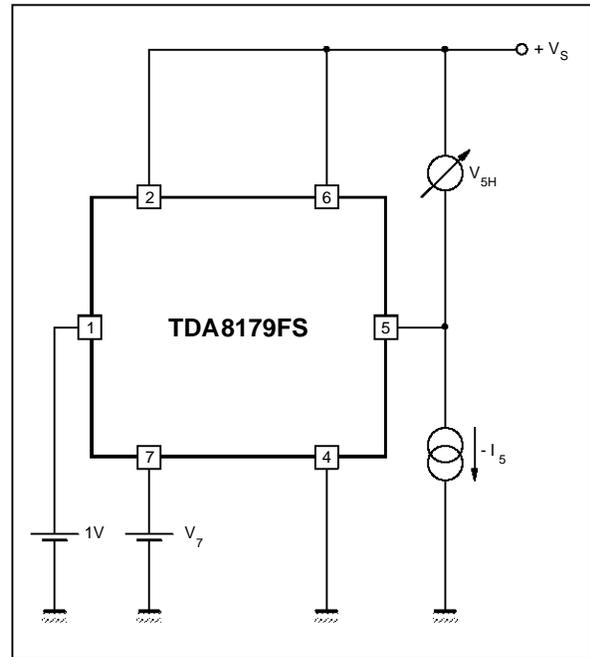

Figure 1c : Measurement of V_{5L}

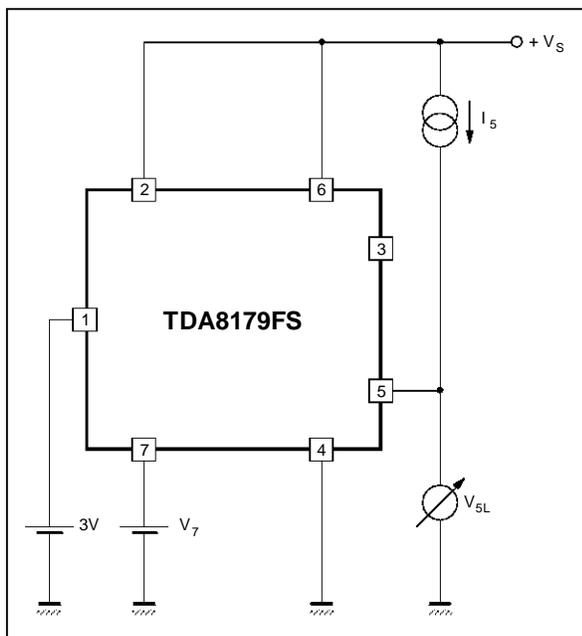

Figure 1d : Measurement of V_5

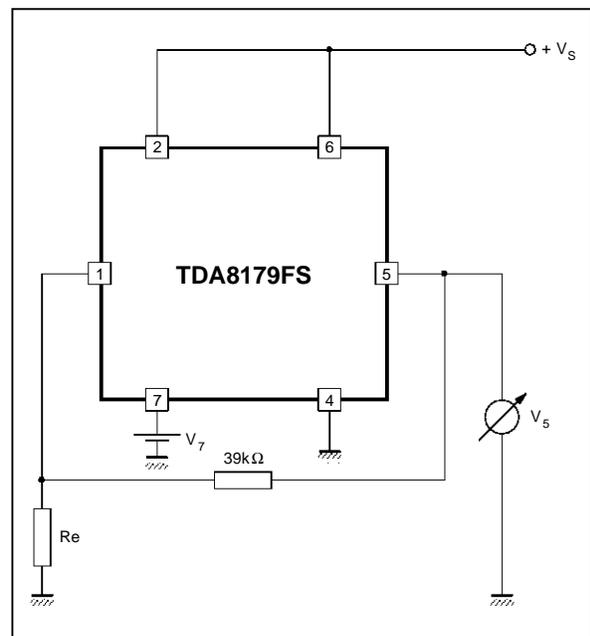

Figure 2 : SOA of Each Output Power Transistor at $T_A = 25^\circ\text{C}$

