



TDA8179S

TV VERTICAL DEFLECTION BOOSTER

- POWER AMPLIFIER
- FLYBACK GENERATOR
- THERMAL PROTECTION

DESCRIPTION

Designed for monitors and high performance TVs, the TDA8179S vertical deflection booster delivers flyback voltages up to 90V.

The TDA8179S operates with supplies up to 42V and provides up to 2App output current to drive to yoke.

The TDA8179S is offered in HEPTAWATT package.

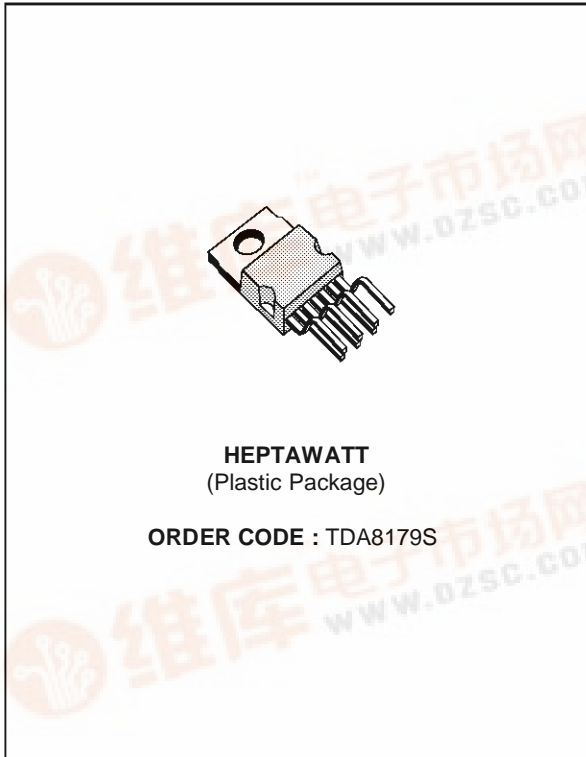

PIN CONNECTIONS

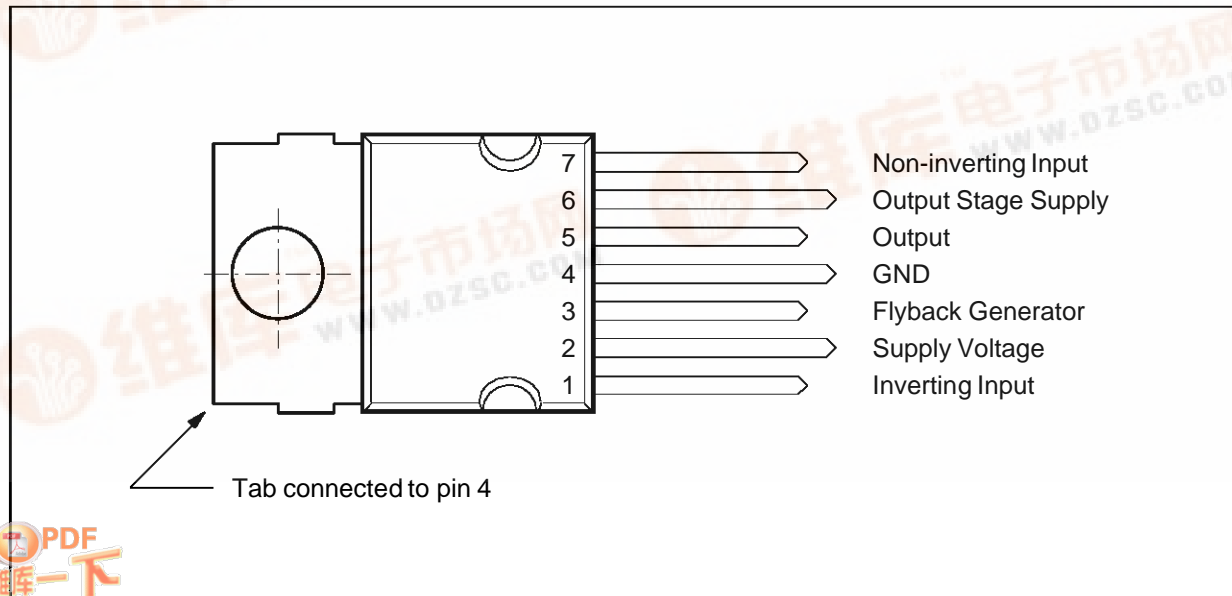

TDA8179S

BLOCK DIAGRAM

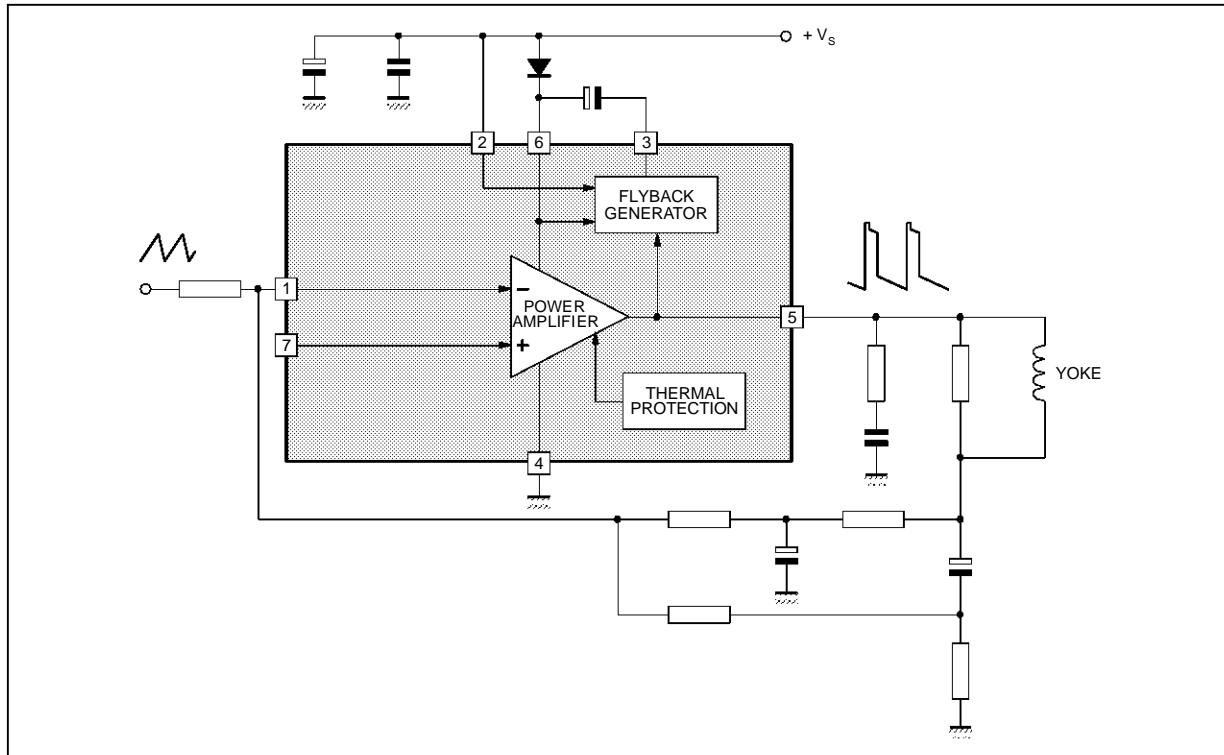

8179S-02.EPS

APPLICATION CIRCUIT

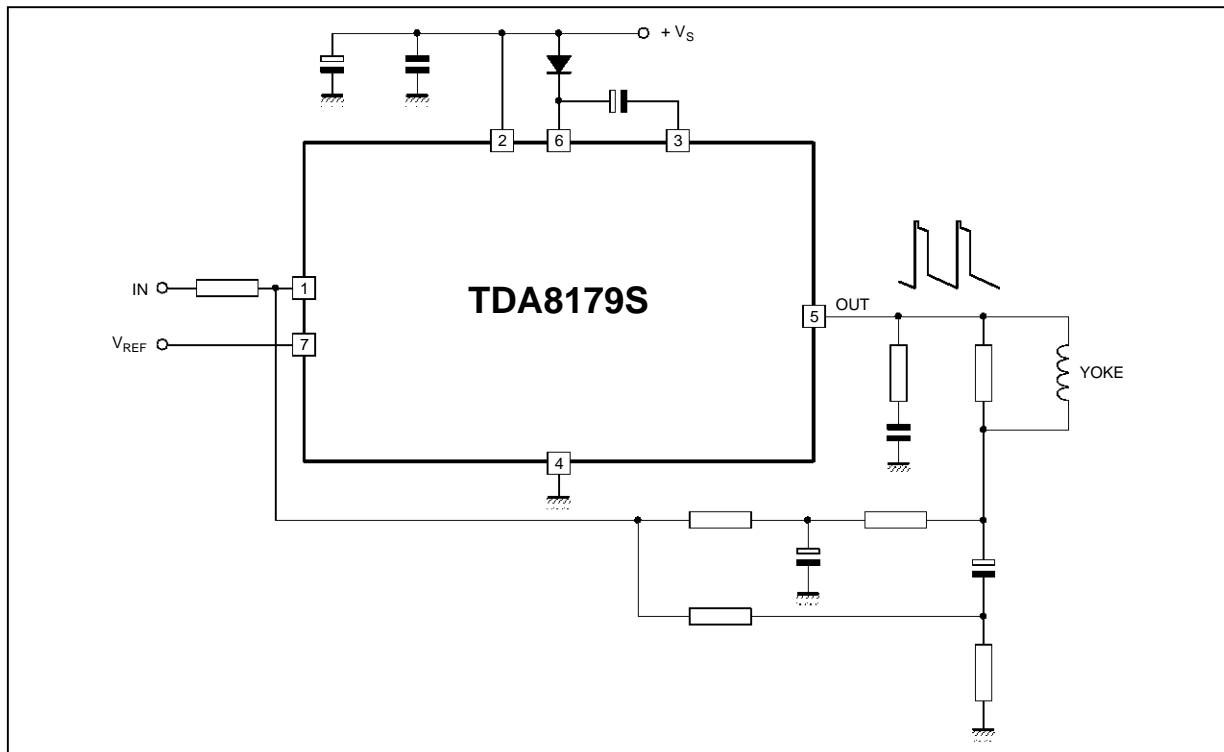

8179S-03.EPS

Note : For values see "Easy Design of Vertical Deflection Stages" (software available from our sales offices)

ABSOLUTE MAXIMUM RATINGS

Symbol	Parameter	Value	Unit
V_S	Supply Voltage (pin 2)	50	V
V_5, V_6	Flyback Peak Voltage	100	V
V_1, V_7	Amplifier Input Voltage	+ V_S	
I_O	Output Peak Current	2 2 1.8	A
	Non-repetitive, $t = 2\text{ms}$ $f = 50$ or 60Hz , $t \leq 10\mu\text{s}$ $f = 50$ or 60Hz , $t > 10\mu\text{s}$		
I_3	Pin 3 DC at $V_5 < V_2$ Pin 3 Peak Flyback Current at $f = 50$ or 60Hz , $t_{\text{fly}} \leq 1.5\text{ms}$	100 1.8	mA A
P_{tot}	Total Power Dissipation at $T_C = 70^\circ\text{C}$	20	W
T_{stg}	Storage Temperature	- 40, + 150	$^\circ\text{C}$
T_j	Junction Temperature	0, +150	$^\circ\text{C}$

8179S-01.TBL

THERMAL DATA

Symbol	Parameter	Value	Unit
$R_{\text{th(j-c)}}$	Junction-case Thermal Resistance	Max. 3	$^\circ\text{C/W}$

8179S-02.TBL

ELECTRICAL CHARACTERISTICS

($V_7 = 2.2\text{V}$, $V_S = 42\text{V}$, $T_A = 25^\circ\text{C}$, unless otherwise specified)
(refer to the test circuits - see Figure 1 next page)

Symbol	Parameter	Test Conditions	Min.	Typ.	Max.	Unit
V_S	Operating Supply Voltage Range		10		42	V
I_2	Pin 2 Quiescent Current	$I_3 = 0$ $I_5 = 0$		10	20	mA
I_6	Pin 6 Quiescent Current	$I_3 = 0$ $I_5 = 0$		20	40	mA
I_1	Amplifier Bias Current	$V_1 = 1\text{V}$		- 0.2	- 1	μA
V_{3L}	Scanning Voltage	$I_3 = 20\text{mA}$		1.3	1.8	V
V_5	Quiescent Output Voltage	$V_S = 42\text{V}$ $R_a = 3.9\text{k}\Omega$ $V_S = 35\text{V}$ $R_a = 5.6\text{k}\Omega$	23.4 17	24.2 17.8	25 18.5	V
V_{5L}	Output Saturation Voltage to GND	$I_5 = 1\text{A}$		1.2	1.5	V
V_{5H}	Output Saturation Voltage to Supply	- $I_5 = 1\text{A}$		2.2	2.6	V
V_{D5-6}	Diode Forward Voltage between Pins 5-6	$I_D = 1\text{A}$		1.5	3	V
V_{D3-2}	Diode Forward Voltage between Pins 3-2	$I_D = 1\text{A}$		1.5	3	V
R_1	Input Resistance			200		$\text{k}\Omega$
T_j	Junction Temperature for Thermal Shutdown			140		$^\circ\text{C}$

8179S-03.TBL

TDA8179S

FIGURE 1 : DC Test Circuits

Figure 1a : Measurement of I_1 , I_2 , I_6

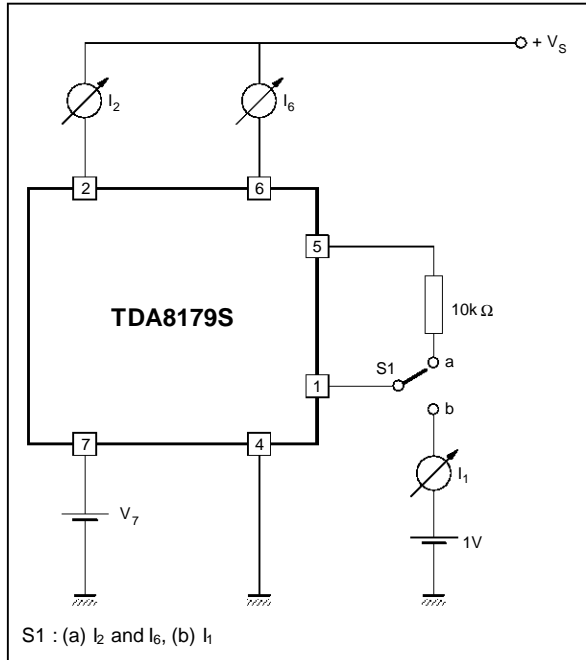

Figure 1b : Measurement of V_{5H}

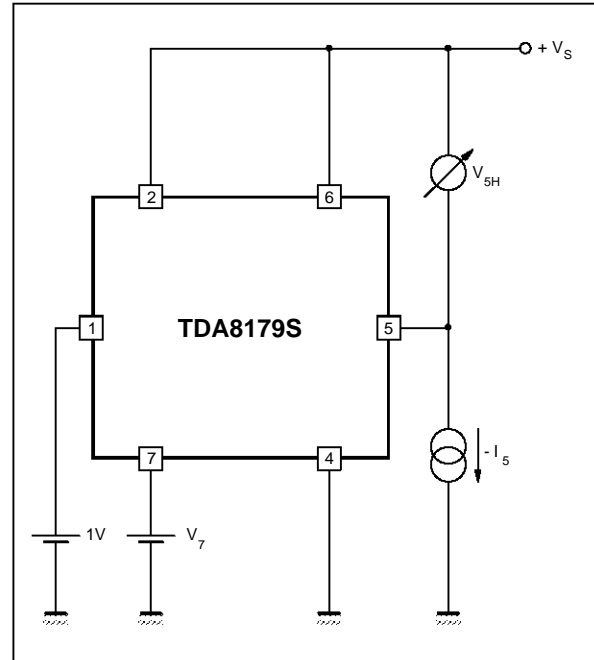

Figure 1c : Measurement of V_{3L} , V_{5L}

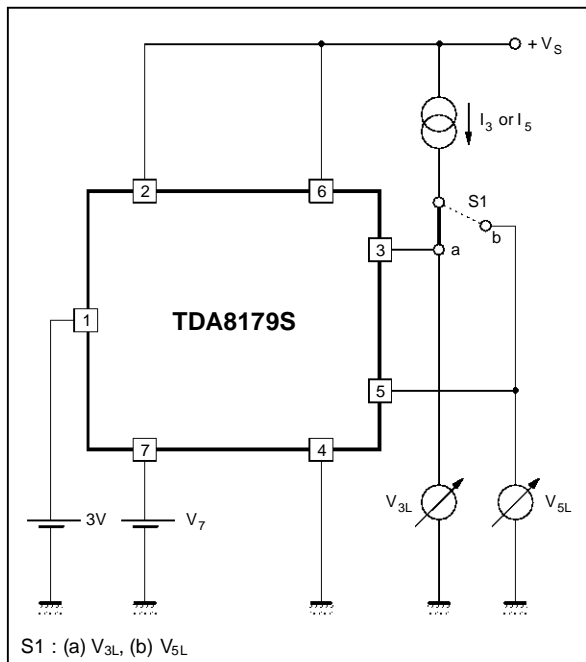

Figure 1d : Measurement of V_5

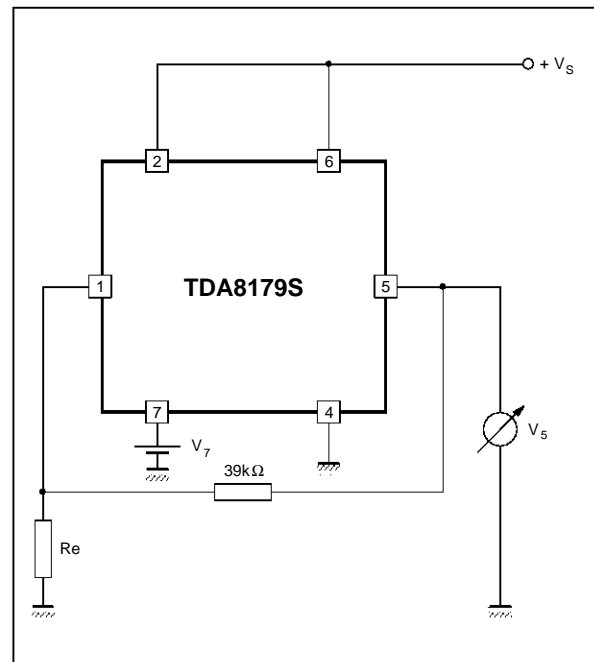
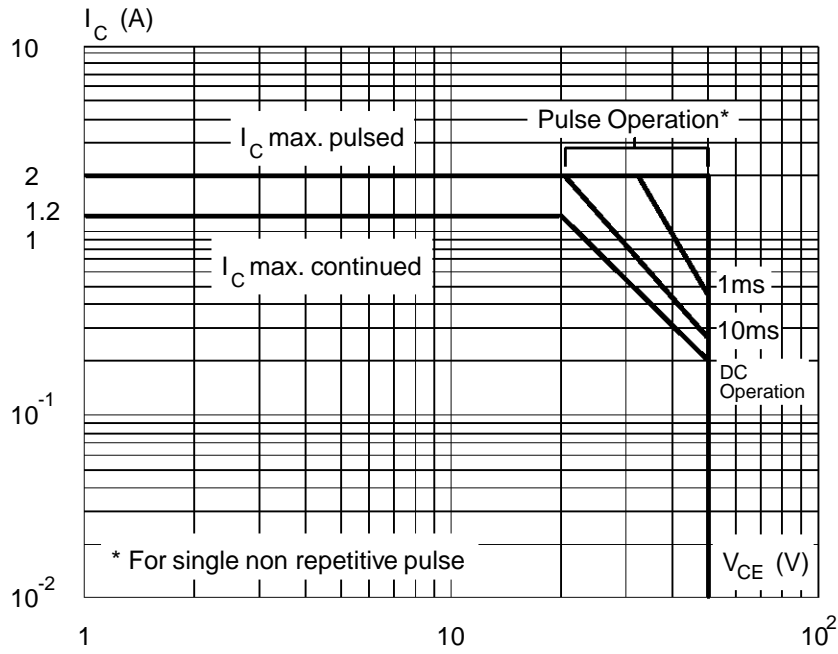

Figure 2 : SOA of Each Output Power Transistor at $T_A = 25^\circ\text{C}$



8179S-08.EPS

TDA8179S

PACKAGE MECHANICAL DATA : HEPTAWATT

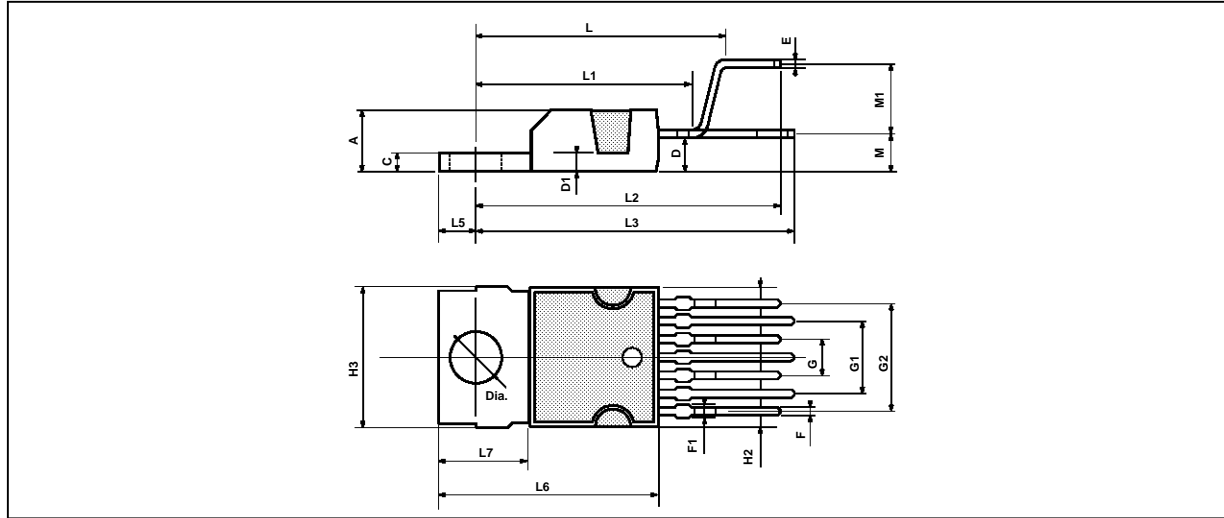

PM-HEPTV.EPS

Dimensions	Millimeters			Inches		
	Min.	Typ.	Max.	Min.	Typ.	Max.
A			4.8			0.189
C			1.37			0.054
D	2.4		2.8	0.094		0.110
D1	1.2		1.35	0.047		0.053
E	0.35		0.55	0.014		0.022
F	0.6		0.8	0.024		0.031
F1			0.9			0.035
G	2.41	2.54	2.67	0.095	0.100	0.105
G1	4.91	5.08	5.21	0.193	0.200	0.205
G2	7.49	7.62	7.8	0.295	0.300	0.307
H2			10.4			0.409
H3	10.05		10.4	0.396		0.409
L		16.97			0.668	
L1		14.92			0.587	
L2		21.54			0.848	
L3		22.62			0.891	
L5	2.6		3	0.102		0.118
L6	15.1		15.8	0.594		0.622
L7	6		6.6	0.236		0.260
M		2.8			0.110	
M1		5.08			0.200	
Dia.	3.65		3.85	0.144		0.152

HEPTV.TBL

Information furnished is believed to be accurate and reliable. However, SGS-THOMSON Microelectronics assumes no responsibility for the consequences of use of such information nor for any infringement of patents or other rights of third parties which may result from its use. No licence is granted by implication or otherwise under any patent or patent rights of SGS-THOMSON Microelectronics. Specifications mentioned in this publication are subject to change without notice. This publication supersedes and replaces all information previously supplied. SGS-THOMSON Microelectronics products are not authorized for use as critical components in life support devices or systems without express written approval of SGS-THOMSON Microelectronics.

© 1994 SGS-THOMSON Microelectronics - All Rights Reserved

Purchase of I²C Components of SGS-THOMSON Microelectronics, conveys a license under the Philips I²C Patent. Rights to use these components in a I²C system, is granted provided that the system conforms to the I²C Standard Specifications as defined by Philips.

SGS-THOMSON Microelectronics GROUP OF COMPANIES

Australia - Brazil - China - France - Germany - Hong Kong - Italy - Japan - Korea - Malaysia - Malta - Morocco
The Netherlands - Singapore - Spain - Sweden - Switzerland - Taiwan - Thailand - United Kingdom - U.S.A.