

**INTEGRATED CIRCUITS**

# DATA SHEET

## TDA8421

Hi-fi stereo audio processor;  
I<sup>2</sup>C bus

Product specification  
File under Integrated Circuits, IC02

May 1988

**Hi-fi stereo audio processor; I<sup>2</sup>C bus****TDA8421****GENERAL DESCRIPTION**

The TDA8421 is a monolithic bipolar integrated stereo sound circuit with a loudspeaker channel (CH1) and a headphone channel (CH2), digital controlled via the I<sup>2</sup>C bus, for application in hi-fi audio and television sound.

**Features**

- Input selector
- Mode selector
- Loudspeaker channel (CH1); with volume control, balance control and mute
- Headphone channel (CH2); with volume control, balance control and mute
- Pseudo stereo and spatial function
- Bass and treble control
- Electrostatic discharge protection diodes

**QUICK REFERENCE DATA**

| PARAMETER                        | SYMBOL   | MIN. | TYP. | MAX. | UNIT |
|----------------------------------|----------|------|------|------|------|
| Supply voltage (pin 4)           | $V_{CC}$ | 7,5  | 12   | 14   | V    |
| Input signal handling            | $V_I$    | 2    | –    | –    | V    |
| Input sensitivity                |          |      |      |      |      |
| full power at the output stage   | $V_i$    | –    | 200  | –    | mV   |
| Signal plus noise-to-noise ratio | (S+N)/N  | –    | 90   | –    | dB   |
| Total harmonic distortion        | THD      | –    | 0,05 | –    | %    |
| Channel separation               | $\alpha$ | –    | 75   | –    | dB   |
| Volume control range CH1         | G        | –62  | –    | 16   | dB   |
| Treble control range             | G        | –12  | –    | 12   | dB   |
| Bass control range               | G        | –12  | –    | 15   | dB   |
| Volume control range CH2         | G        | –62  | –    | 0    | dB   |

**PACKAGE OUTLINE**

28-lead dual in-line; plastic (SOT117); SOT 117-1; 1996 november 19.

Hi-fi stereo audio processor; I<sup>2</sup>C bus

TDA8421

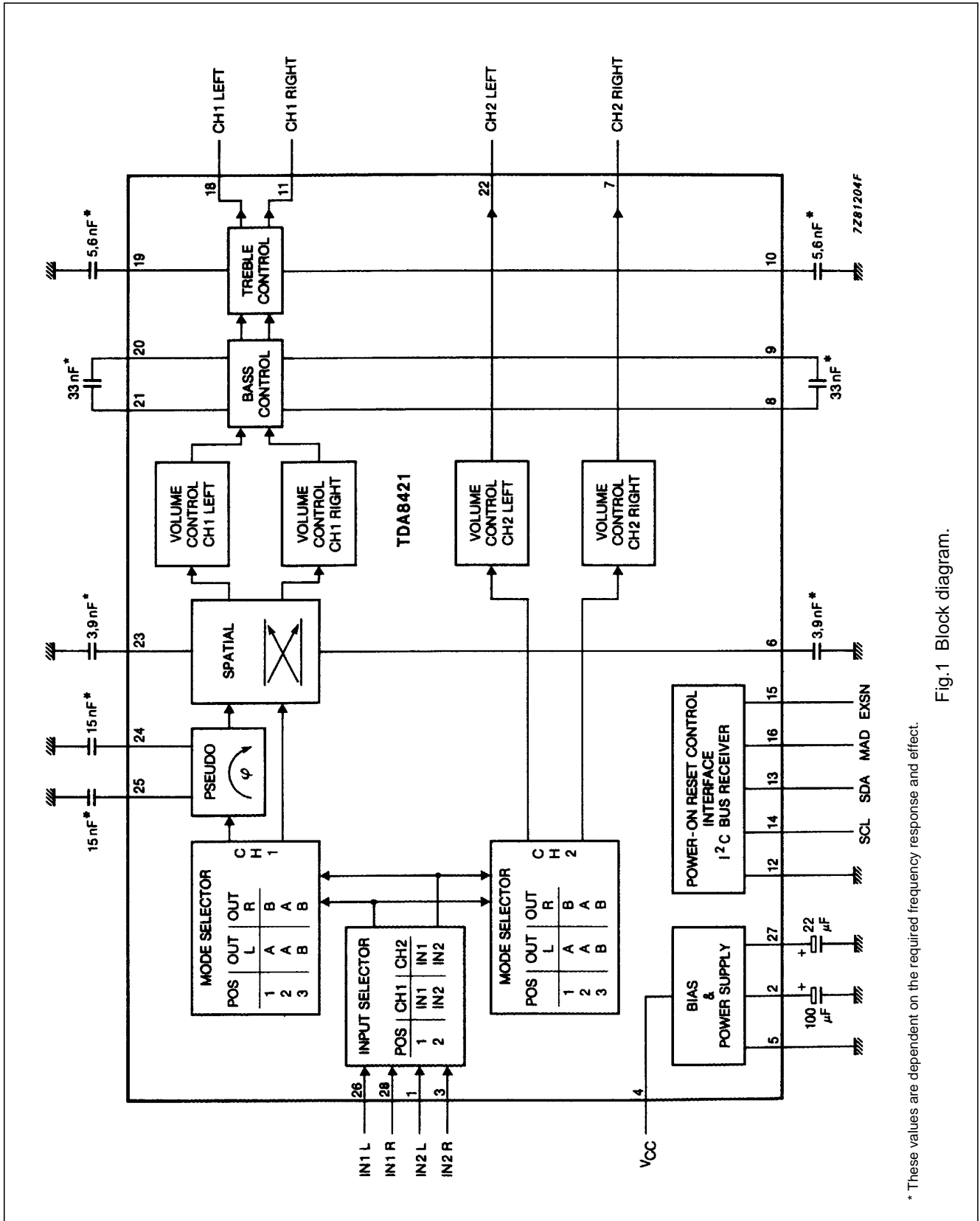

\* These values are dependent on the required frequency response and effect.

Hi-fi stereo audio processor; I<sup>2</sup>C bus

TDA8421

## PINNING

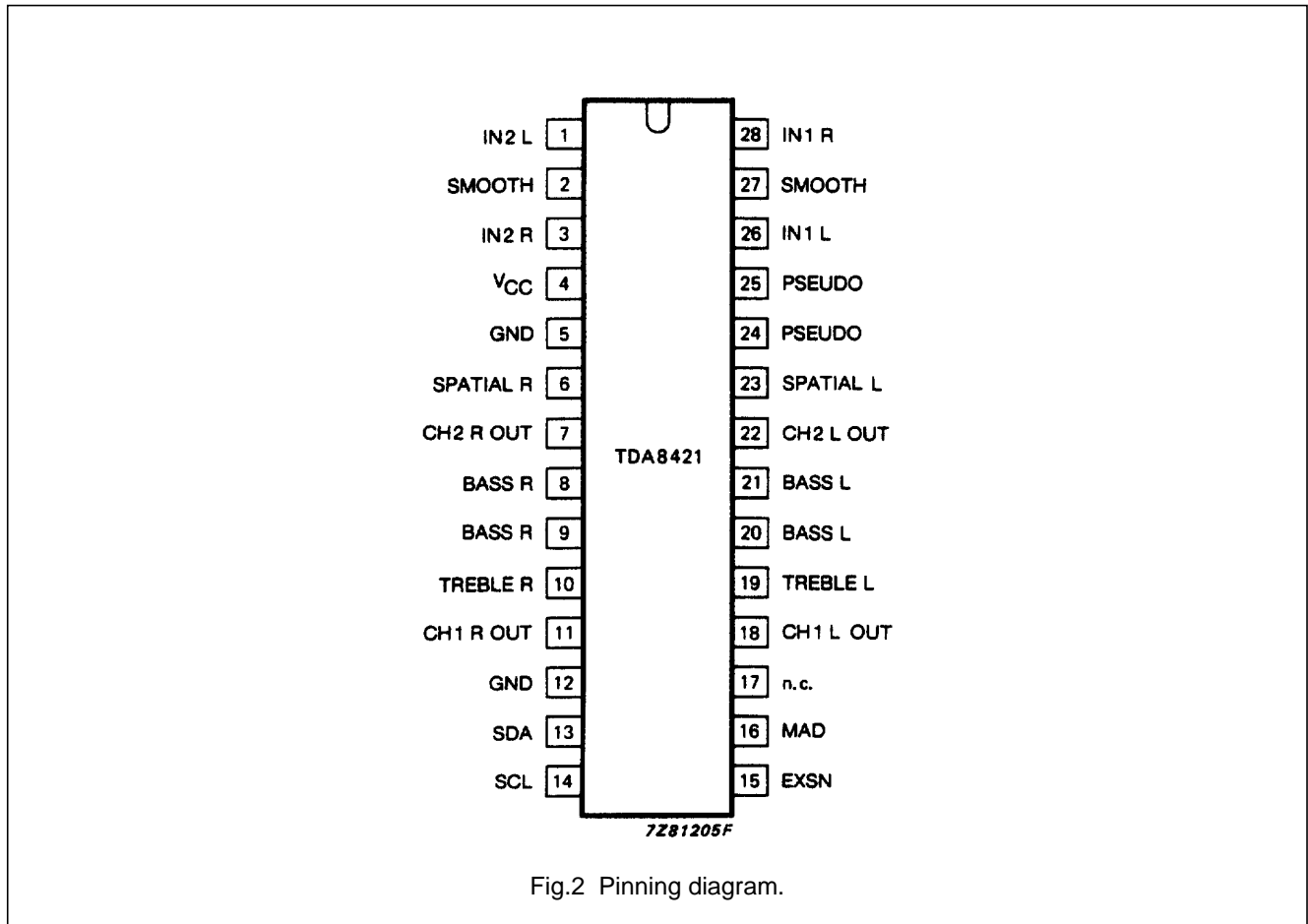

## FUNCTIONAL DESCRIPTION

## Input selector

The input to channel 1 (CH1) and channel 2 (CH2) is determined by the input selector. The selection is made from the following AF input signals:

- IN1 L (pin 26); IN1 R (pin 28) or
- IN2 L (pin 1); IN2 R (pin 3)

Where IN1 is an internal input signal and IN2 an external input signal.

## Mode selector

For each channel (CH1 and CH2) there is a mode selector which selects between stereo, sound A and sound B in the event of bilingual transmission. Both mode selectors can be controlled independently.

Hi-fi stereo audio processor; I<sup>2</sup>C bus

## TDA8421

**Headphone channel (CH2)**

Volume control and balance

The stages for volume control for CH2 consist of two parts for left and right. In each part the gain can be adjusted between 0 and -62 dB in steps of 2 dB. An additional step allows an attenuation of  $\geq 90$  dB. Both parts can be controlled independently over the whole range, which allows the balance to be varied by controlling the volume of left and right.

**Loudspeaker channel (CH1)**

Volume control and balance

The loudspeaker channel (CH1) also consists of two parts for volume control (left and right). In each part the gain can be adjusted between + 16 dB and -62 dB in steps of 2 dB. An additional step allows an attenuation of  $\geq 90$  dB. Both parts can be controlled independently over the whole range, which allows the balance to be varied by controlling the volume of left and right.

**Stereo/pseudo stereo/spatial stereo mode**

It is possible to select three modes. Stereo, pseudo or spatial stereo. The pseudo stereo mode receives mono transmissions and the stereo and spatial stereo mode receives stereo transmissions.

**Bass control**

The bass control stage can be switched from an emphasis of 15 dB to an attenuation of 12 dB for low frequencies in steps of 3 dB.

**Treble control**

The treble control stage can be switched from + 12 dB to -12 dB in steps of 3 dB.

**Bias and power supply**

The TDA8421 includes a bias and power supply stage, which generates a voltage of  $\frac{1}{2} V_{CC}$  with a low output impedance and injector currents for the logic part.

**Power-on reset**

The on-chip power-on reset circuit sets the mute bit to active, which mutes both the loudspeaker channel (CH1) and the headphone channel (CH2). The muting can be switched by transmission of the mute bit.

**I<sup>2</sup>C bus receiver and data handling**

Bus specification

The TDA8421 is controlled via the 2-wire I<sup>2</sup>C bus by a microcomputer. The two wires (SDA - serial data, SCL - serial clock) carry information between the devices connected to the bus. Both SDA and SCL are bidirectional lines, connected to a positive supply voltage via a pull up resistor.

When the bus is free both lines are HIGH. The data on the SDA line must be stable during the HIGH period of the clock. The HIGH or LOW state of the data line can only change when the clock signal on the SCL line is LOW. The set up and hold times are specified in AC CHARACTERISTICS.

A HIGH-to-LOW transition of the SDA line while SCL is HIGH is defined as a start condition. A LOW-to-HIGH transition of the SDA line while SCL is HIGH is defined as a stop condition. The bus receiver will be reset by the reception of a start condition. The bus is considered to be busy after the start condition. The bus is considered to be free again after a stop condition.

**Module address**

Data transmission to the TDA8421 starts with the module address MAD.

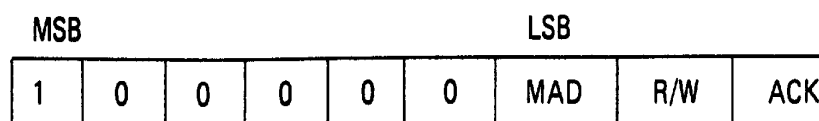

Fig.3 TDA8421 module address.

The module address is determined by pin 16. When connected to ground MAD = 0; when connected to  $V_{CC}$  MAD = 1. Thus two TDA8421s can be selected within a system.

Hi-fi stereo audio processor; I<sup>2</sup>C bus

TDA8421

**Subaddress**

After the module address byte a second byte is used to select the functions for both channels:

- CH1 - Volume left, volume right, bass, treble and switch functions
- CH2 - Volume left, volume right and switch functions

The subaddress SAD is stored within the TDA8421. Table 1 defines the coding of the second byte after the module address MAD.

**Table 1** Second byte after module address MAD

| FUNCTION       | 128              | 64 | 32 | 16 | 8   | 4 | 2 | 1 |   |
|----------------|------------------|----|----|----|-----|---|---|---|---|
|                | MSB              |    |    |    | LSB |   |   |   |   |
|                | 7                | 6  | 5  | 4  | 3   | 2 | 1 | 0 |   |
| CH1            | volume left      | 0  | 0  | 0  | 0   | 0 | 0 | 0 | 0 |
|                | volume right     | 0  | 0  | 0  | 0   | 0 | 0 | 0 | 1 |
|                | bass             | 0  | 0  | 0  | 0   | 0 | 0 | 1 | 0 |
|                | treble           | 0  | 0  | 0  | 0   | 0 | 0 | 1 | 1 |
|                | switch functions | 0  | 0  | 0  | 0   | 1 | 0 | 0 | 0 |
| CH2            | volume left      | 0  | 0  | 0  | 0   | 0 | 1 | 0 | 0 |
|                | volume right     | 0  | 0  | 0  | 0   | 0 | 1 | 0 | 1 |
|                | switch functions | 0  | 0  | 0  | 0   | 1 | 1 | 0 | 0 |
| subaddress SAD |                  |    |    |    |     |   |   |   |   |

**Definition of 3rd byte**

A third byte is used to transmit data to the TDA8421. Table 2 defines the coding of the third byte after module address MAD and subaddress SAD.

**Table 2** Third byte after module address MAD and subaddress SAD

| FUNCTION |                  | MSB |   |   |     |     |     |     | LSB |     |
|----------|------------------|-----|---|---|-----|-----|-----|-----|-----|-----|
|          |                  | 7   | 6 | 5 | 4   | 3   | 2   | 1   | 0   |     |
| CH1      | volume left      | VL1 | 1 | 1 | V05 | V04 | V03 | V02 | V01 | V00 |
|          | volume right     | VR1 | 1 | 1 | V15 | V14 | V13 | V12 | V11 | V10 |
|          | bass             | BA  | 1 | 1 | 1   | 1   | BA3 | BA2 | BA1 | BA0 |
|          | treble           | TR  | 1 | 1 | 1   | 1   | TR3 | TR2 | TR1 | TR0 |
|          | switch functions | S1  | 1 | 1 | MU  | EFL | STL | ML1 | ML0 | IS  |
| CH2      | volume left      | VL2 | 1 | 1 | V25 | V24 | V23 | V22 | V21 | V20 |
|          | volume right     | VR2 | 1 | 1 | V35 | V34 | V33 | V32 | V31 | V30 |
|          | switch functions | S2  | 1 | 1 | 1   | 1   | EXS | MH1 | MH0 | 1   |

Hi-fi stereo audio processor; I<sup>2</sup>C bus

## TDA8421

**Truth tables**

Truth tables for the switch functions

**Table 3** Input selector

| function | IS |
|----------|----|
| IN1      | 0  |
| IN2      | 1  |

**Table 5** Stereo/pseudo stereo/spatial stereo

| choise  | STL | EFL |
|---------|-----|-----|
| spatial | 1   | 1   |
| stereo  | 1   | 0   |
| pseudo  | 0   | 1   |
| -----   | 0   | 0   |

**Table 7** Output for external switch

| EXSN           | EXS |
|----------------|-----|
| ground         | 1   |
| open collector | 0   |

Truth tables for the volume base and treble controls.

**Table 8** Volume control

| CH1  | CH2  | V × 5 | V × 4 | V × 3 | V × 2 | V × 1 | V × 0 |
|------|------|-------|-------|-------|-------|-------|-------|
| 16   | 0    | 1     | 1     | 1     | 1     | 1     | 1     |
| 14   | -2   | .     | .     | .     | .     | .     | .     |
| .    | .    | .     | .     | .     | .     | .     | .     |
| .    | .    | .     | .     | .     | .     | .     | .     |
| .    | .    | .     | .     | .     | .     | .     | .     |
| -46  | -62  | 1     | 0     | 0     | 0     | 0     | 0     |
| -48  | ≤-90 | 0     | 1     | 1     | 1     | 1     | 1     |
| .    | .    | .     | .     | .     | .     | .     | .     |
| -62  | ≤-90 | 0     | 1     | 1     | 0     | 0     | 0     |
| ≤-90 | ≤-90 | 0     | 1     | 0     | 1     | 1     | 1     |
| .    | .    | .     | .     | .     | .     | .     | .     |
| .    | .    | .     | .     | .     | .     | .     | .     |
| .    | .    | .     | .     | .     | .     | .     | .     |
| ≤-90 | ≤-90 | 0     | 0     | 0     | 0     | 0     | 0     |

**Note**

1. The values of CH1 and CH2 are in 2 dB/step measured in dBs.

**Table 4** Mode selectors

| mode    | CH1 |     | CH2 |     |
|---------|-----|-----|-----|-----|
|         | ML0 | ML1 | MH0 | MH1 |
| stereo  | 1   | 1   | 1   | 1   |
| sound A | 1   | 0   | 1   | 0   |
| sound B | 0   | 1   | 0   | 1   |
| -----   | 0   | 0   | 0   | 0   |

**Table 6** Mute

| mute  | MU |
|---|----|
| active; automatic<br>after POR <sup>(1)</sup> | 1  |
| not active                                    | 0  |

**Notes**

1. Attenuation ≥ 90 dB; POR = Power-On Reset.

Hi-fi stereo audio processor; I<sup>2</sup>C bus

TDA8421

**Table 9** Bass control

| 3dB/STEP<br>(dB) | BA3 | BA2 | BA1 | BA0 |
|------------------|-----|-----|-----|-----|
| 15               | 1   | 1   | 1   | 1   |
| ---              | --- | --- | --- | --- |
| ---              | --- | --- | --- | --- |
| ---              | --- | --- | --- | --- |
| 15               | 1   | 0   | 1   | 1   |
| 12               | 1   | 0   | 1   | 0   |
| ---              | --- | --- | --- | --- |
| ---              | --- | --- | --- | --- |
| ---              | --- | --- | --- | --- |
| 0                | 0   | 1   | 1   | 0   |
| ---              | --- | --- | --- | --- |
| ---              | --- | --- | --- | --- |
| ---              | --- | --- | --- | --- |
| -12              | 0   | 0   | 1   | 0   |
| ---              | --- | --- | --- | --- |
| ---              | --- | --- | --- | --- |
| ---              | --- | --- | --- | --- |
| -12              | 0   | 0   | 0   | 0   |

**Table 10** Treble control

| 3dB/STEP<br>(dB) | TR3 | TR2 | TR1 | TR0 |
|------------------|-----|-----|-----|-----|
| 12               | 1   | 1   | 1   | 1   |
| ---              | --- | --- | --- | --- |
| ---              | --- | --- | --- | --- |
| ---              | --- | --- | --- | --- |
| 12               | 1   | 0   | 1   | 0   |
| ---              | --- | --- | --- | --- |
| ---              | --- | --- | --- | --- |
| ---              | --- | --- | --- | --- |
| 0                | 0   | 1   | 1   | 0   |
| ---              | --- | --- | --- | --- |
| ---              | --- | --- | --- | --- |
| ---              | --- | --- | --- | --- |
| -12              | 0   | 0   | 1   | 0   |
| ---              | --- | --- | --- | --- |
| ---              | --- | --- | --- | --- |
| ---              | --- | --- | --- | --- |
| -12              | 0   | 0   | 0   | 0   |



Hi-fi stereo audio processor; I<sup>2</sup>C bus

TDA8421

**Sequence of data transmission**

After a power-on reset all eight functions have to be adjusted with eight data transmissions. It is recommended that data information for switch functions in CH1 are transmitted last because all functions have to be adjusted when the muting is switched off. The sequence of transmission of other data information is not critical.

The order of data transmission is shown in Figures 4 and 5. The number of data transmissions is unrestricted but before each data byte the module address MAD and the correct subaddress SAD is required.

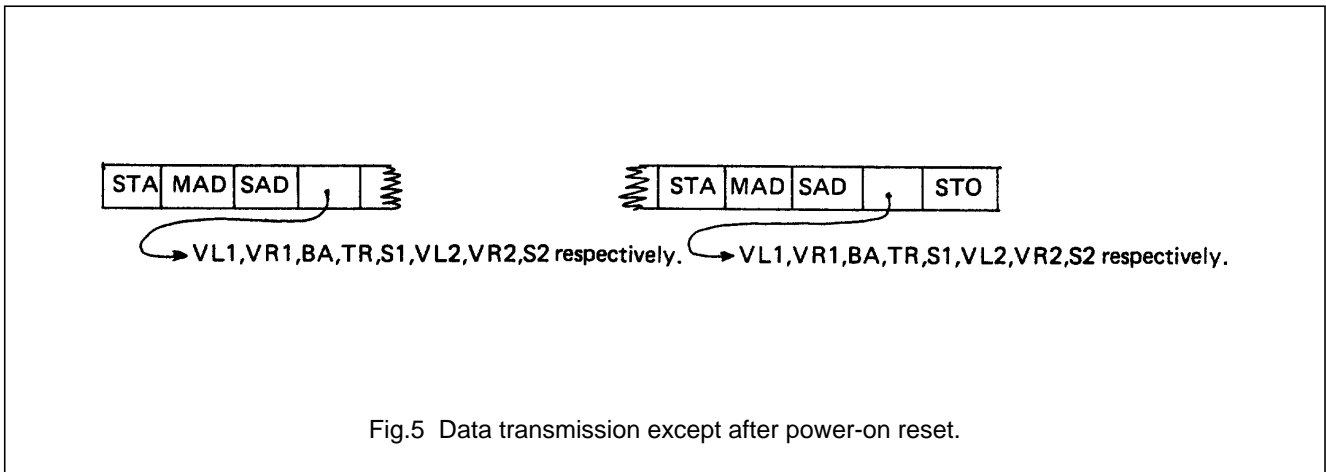
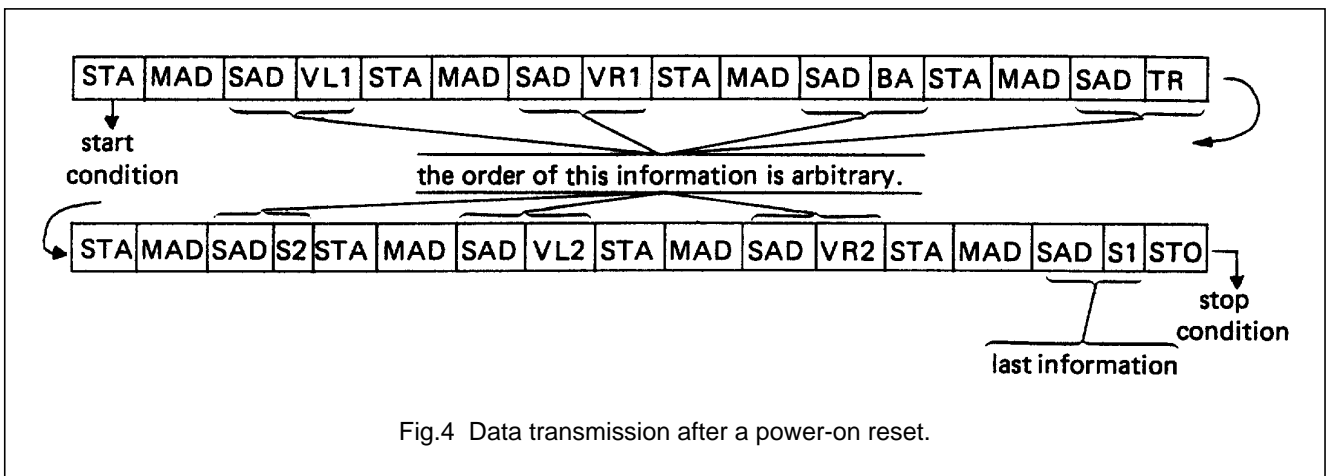

Hi-fi stereo audio processor; I<sup>2</sup>C bus

## TDA8421

**RATINGS**

Limiting values in accordance with the Absolute Maximum System (IEC 134)

| PARAMETER                                     | SYMBOL                          | MIN. | MAX.            | UNIT |
|---|---------------------------------|------|-----------------|------|
| Supply voltage                                | V <sub>CC</sub>                 | 0    | 16              | V    |
| Voltage range at pins for external capacitors |                                 |      |                 |      |
| pins 2, 6, 8 to 10, 19 to 21, 23 to 25, 27    | V <sub>cap</sub>                | 0    | V <sub>CC</sub> | V    |
| pin 13  | V <sub>SDA</sub>                | 0    | V <sub>CC</sub> | V    |
| pin 14  | V <sub>SCL</sub>                | 0    | V <sub>CC</sub> | V    |
| pin 15  | V <sub>EXSN</sub>               | 0    | V <sub>CC</sub> | V    |
| pin 16  | V <sub>MAD</sub>                | 0    | V <sub>CC</sub> | V    |
| Voltage range                                 |                                 |      |                 |      |
| at pins 1, 3, 7, 11, 18, 22, 26, 28           | V <sub>I</sub> , V <sub>O</sub> | 0    | V <sub>CC</sub> | V    |
| Output current at pins 7, 11, 18, 22          | I <sub>O</sub>                  | –    | 45              | mA   |
| Total power dissipation                       |                                 |      |                 |      |
| at T <sub>amb</sub> < 70 °C                   | P <sub>tot</sub>                | –    | 1350            | mW   |
| Operating ambient temperature range           | T <sub>amb</sub>                | 0    | 70              | °C   |
| Storage temperature range                     | T <sub>stg</sub>                | –25  | 150             | °C   |
| Electrostatic handling <sup>(1)</sup>         | ±V <sub>ESD</sub>               | –    | 2000            | V    |

**Note**

1. Equivalent to discharging a 100 pF capacitor through a 1,5 kΩ resistor.

Hi-fi stereo audio processor; I<sup>2</sup>C bus

TDA8421

**DC CHARACTERISTICS** $V_{CC} = 12\text{ V}$ ;  $T_{amb} = 25\text{ °C}$ ; unless otherwise specified

| PARAMETER   | SYMBOL                                  | MIN. | TYP.   | MAX.     | UNIT            |
|---|---|------|--|----------|-----------------|
| Supply voltage (pin 4)  | $V_{CC}$                                | 7,5  | 12   | 14       | V               |
| Supply current<br>at $V_{CC} = 12\text{ V}$   | $I_{CC}$                                | –    | 42   | 55       | mA              |
| Internal input voltage<br>IN1 L,R (pins 26,28) IN2 L,R (pins<br>1,3) DC voltage internally generated;<br>capacitive coupling recommended        | $V_I$                                   | 5,4  | 6,0  | 6,6      | V               |
| MAD (pin 16)<br>input voltage HIGH  | $V_{IH}$                                | 3,0  | –  | $V_{CC}$ | V               |
| input voltage LOW   | $V_{IL}$                                | 0    | –  | 1,5      | V               |
| input current HIGH  | $I_{IH}$                                | –    | –  | 1,0      | $\mu\text{A}$   |
| input current LOW   | $I_{IL}$                                | –    | 1  | 10       | $\mu\text{A}$   |
| SDA; SCL (pins 13 and 14)<br>input voltage HIGH   | $V_{IH}$                                | 3,0  | –  | $V_{CC}$ | V               |
| input voltage LOW   | $V_{IL}$                                | –0,3 | –  | 1,5      | V               |
| input current HIGH  | $I_{IH}$                                | –    | –  | 1,0      | $\mu\text{A}$   |
| input current LOW   | $I_{IL}$                                | –    | 1  | 10       | $\mu\text{A}$   |
| Output voltage at<br>CH1 (pins 11 and 18);<br>CH2 (pins 7 and 22)<br>pins with external capacitors<br>pins 6 to 10; 19 to 21; 23 to 25<br>pin 2 | $V_O$<br><br>$V_{cap,n}$<br>$V_{cap,2}$ | 5,4  | $\frac{1}{2} V_{CC}$<br><br>$\frac{1}{2} V_{CC}$<br>$V_{CC}-0,1$ | 6,6      | V<br><br>V<br>V |
| External switch (pin 15)<br>at $I_{EXSN} = 1\text{ mA}$   |   |      |  |          |                 |
| Output voltage HIGH   | $V_{EXSNH}$                             | –    | –  | 16       | V               |
| Output voltage LOW  | $V_{EXSNL}$                             | –    | –  | 0,3      | V               |

Hi-fi stereo audio processor; I<sup>2</sup>C bus

TDA8421

**AC CHARACTERISTICS** $V_{CC} = 12\text{ V}$ ; bass/treble in linear position; pseudo and spatial stereo off;  $R_L > 10\text{ k}\Omega$ ;  $C_L < 100\text{ pF}$ ; $T_{amb} = 25\text{ }^\circ\text{C}$  unless otherwise specified.

| PARAMETER  | SYMBOL        | MIN. | TYP. | MAX.   | UNIT             |
|--|---------------|------|------|--------|------------------|
| <b>I<sup>2</sup>C bus timing (see Fig.6)</b>   |               |      |      |        |                  |
| SDA, SCL (pin 13 and 14)   |               |      |      |        |                  |
| Clock frequency range  | $f_{SCL}$     | 0    | –    | 100    | kHz              |
| The HIGH period of the clock   | $t_{HIGH}$    | 4    | –    | –      | $\mu\text{s}$    |
| The LOW period of the clock  | $t_{LOW}$     | 4,7  | –    | –      | $\mu\text{s}$    |
| SCL rise time  | $t_r$         | –    | –    | 1      | $\mu\text{s}$    |
| SCL fall time  | $t_f$         | –    | –    | 0,3    | $\mu\text{s}$    |
| Set-up time for start condition  | $t_{SU;STA}$  | 4,7  | –    | –      | $\mu\text{s}$    |
| Hold time for start condition  | $t_{HD; STA}$ | 4    | –    | –      | $\mu\text{s}$    |
| Set-up time for stop condition   | $t_{SU; STO}$ | 4,7  | –    | –      | $\mu\text{s}$    |
| Time bus must be free before a new transmission can start  | $t_{BUF}$     | 4,7  | –    | –      | $\mu\text{s}$    |
| Set-up time DATA   | $t_{SU; DAT}$ | 250  | –    | –      | ns               |
| <b>Input signals</b>   |               |      |      |        |                  |
| IN1 L (pin 26) IN1 R (pin 28)<br>IN2 L (pin 1) IN2 R (pin 3)   |               |      |      |        |                  |
| Input signal handling (r.m.s. value)<br>at $V_u = -4\text{ dB}$ ; $\text{THD} \leq 0,5\%$                  | $V_{i(rms)}$  | 2    | –    | –      | V                |
| Input resistance   | $R_{n-5}$     | 35   | 50   | –      | $\text{k}\Omega$ |
| Frequency response ( $-0,5\text{ dB}$ )<br>bass and treble in linear position;<br>stereo mode; effects off | f             | 20   | –    | 20 000 | Hz               |

Hi-fi stereo audio processor; I<sup>2</sup>C bus

## TDA8421

| PARAMETER                             | SYMBOL            | MIN. | TYP. | MAX. | UNIT |
|---------------------------------------|-------------------|------|------|------|------|
| <b>LOUDSPEAKER CHANNEL OUTPUTS</b>    |                   |      |      |      |      |
| CH1 LEFT (pin 18); CH1 RIGHT (pin 11) |                   |      |      |      |      |
| Output voltage range (r.m.s. value)   |                   |      |      |      |      |
| at THD ≤ 0,5%                         | $V_{o(rms)}$      | 2    | –    | –    | V    |
| Load resistance                       | $R_L$             | 10   | –    | –    | kΩ   |
| Output impedance                      | $Z_O$             | –    | –    | 100  | Ω    |
| Noise level                           |                   |      |      |      |      |
| weighted according to CCIR468-2       |                   |      |      |      |      |
| gain = 16 dB                          | $V_n$             | –    | 90   | –    | μV   |
| gain = 0 dB                           | $V_n$             | –    | 20   | 40   | μV   |
| gain = ≤ –90 dB                       | $V_n$             | –    | 15   | –    | μV   |
| Total harmonic distortion             |                   |      |      |      |      |
| (f = 20 Hz to 12,5 kHz)               |                   |      |      |      |      |
| for $V_{i(rms)} = 0,5$ V;             |                   |      |      |      |      |
| gain = + 16 dB to –30 dB              | THD               | –    | 0,05 | 0,2  | %    |
| for $V_{i(rms)} = 1,0$ V;             |                   |      |      |      |      |
| gain = +2 dB to –30 dB                | THD               | –    | 0,07 | 0,2  | %    |
| for $V_{i(rms)} = 2,0$ V;             |                   |      |      |      |      |
| gain = –4 dB to –30 dB                | THD               | –    | 0,1  | –    | %    |
| Channel separation at 10 kHz          |                   |      |      |      |      |
| gain = 0 dB                           | $\alpha_{cr}$     | –    | 75   | –    | dB   |
| Ripple rejection (gain = 0 dB;        |                   |      |      |      |      |
| bass and treble in linear position)   |                   |      |      |      |      |
| $f_{ripple} = 100$ Hz                 | RR <sub>100</sub> | –    | 50   | –    | dB   |
| Crosstalk attenuation from logic      |                   |      |      |      |      |
| inputs to AF outputs (gain = 0 dB;    |                   |      |      |      |      |
| bass and treble in linear position)   |                   |      |      |      |      |
|                                       | $\alpha_L$        | –    | 110  | –    | dB   |
| <b>VOLUME CONTROL</b>                 |                   |      |      |      |      |
| For truth table see Table 8           |                   |      |      |      |      |

Hi-fi stereo audio processor; I<sup>2</sup>C bus

## TDA8421

| PARAMETER   | SYMBOL            | MIN. | TYP. | MAX. | UNIT    |
|---|-------------------|------|------|------|---------|
| <b>Loudspeaker channel (CH1)</b>                              |                   |      |      |      |         |
| Control range at f = 1 kHz                                    |                   |      |      |      |         |
| maximum voltage gain (16 dB step)                             | G <sub>max</sub>  | 15   | –    | –    | dB      |
| minimum voltage gain (–62 dB step)                            | G <sub>min</sub>  | –60  | –    | –    | dB      |
| last position   | G <sub>off</sub>  | –80  | –85  | –    | dB      |
| mute position   | G <sub>mute</sub> | –85  | –90  | –    | dB      |
| Resolution  | G <sub>step</sub> | –    | 2    | –    | dB/step |
| Gain difference between left and right AF channel (note 1)    |                   |      |      |      |         |
| gain from 16 dB to –30 dB                                     | ΔG                | –    | –    | 0,5  | dB      |
| gain from –30 dB to –62 dB                                    | ΔG                | –    | –    | 1    | dB      |
| <b>TREBLE CONTROL (CH1)</b>                                   |                   |      |      |      |         |
| For truth table see Table 10                                  |                   |      |      |      |         |
| Control range   |                   |      |      |      |         |
| for C <sub>10-5</sub> ; C <sub>19-5</sub> = 5,6 nF            |                   |      |      |      |         |
| Maximum emphasis at 15 kHz with respect to linear position    | G                 | 11   | 12   | 13   | dB      |
| Maximum attenuation at 15 kHz with respect to linear position | G                 | 11   | 12   | 13   | dB      |
| Resolution  | G <sub>step</sub> | –    | 3    | –    | dB/step |
| <b>BASS CONTROL</b>   |                   |      |      |      |         |
| For truth table see Table 9                                   |                   |      |      |      |         |
| Control range   |                   |      |      |      |         |
| for C <sub>8-9</sub> ; C <sub>20-21</sub> = 33 nF             |                   |      |      |      |         |
| Maximum emphasis at 40 kHz with respect to linear position    | G                 | 14   | 15   | 16   | dB      |
| Maximum attenuation at 40 kHz with respect to linear position | G                 | 11   | 12   | 13   | dB      |
| Resolution  | G <sub>step</sub> | –    | 3    | –    | dB/step |
| <b>SPATIAL AND PSEUDO FUNCTION</b>                            |                   |      |      |      |         |
| Spatial:  |                   |      |      |      |         |
| Antiphase crosstalk   | α                 | –    | 50   | –    | %       |
| Pseudo:   |                   |      |      |      |         |
| Phase shift (see Fig.15)                                      |                   |      |      |      |         |

Hi-fi stereo audio processor; I<sup>2</sup>C bus

## TDA8421

| PARAMETER   | SYMBOL            | MIN. | TYP. | MAX. | UNIT |
|---|-------------------|------|------|------|------|
| <b>HEADPHONE CHANNEL OUTPUTS</b>  |                   |      |      |      |      |
| CH2 LEFT (pin 22); CH2 RIGHT (pin 7)                                      |                   |      |      |      |      |
| Output voltage range (r.m.s. value)                                       |                   |      |      |      |      |
| at THD ≤ 0,5%   | $V_{o(rms)}$      | 2    | –    | –    | V    |
| Load resistance   | $R_L$             | 10   | –    | –    | kΩ   |
| Output impedance  | $Z_O$             | –    | –    | 100  | Ω    |
| Noise level   |                   |      |      |      |      |
| (weighted according to CCIR468-2)   |                   |      |      |      |      |
| gain = 0 dB   | $V_n$             | –    | 15   | –    | μV   |
| gain = 16 dB  | $V_n$             | –    | 12   | 25   | μV   |
| gain = ≤ –90 dB   | $V_n$             | –    | 10   | –    | μV   |
| Total harmonic distortion   |                   |      |      |      |      |
| (f = 20 Hz to 12,5 kHz)   |                   |      |      |      |      |
| for $V_{i(rms)} = 0,2$ V;<br>gain = 0 dB to –30 dB                        | THD               | –    | 0,01 | 0,2  | %    |
| for $V_{i(rms)} = 1,0$ V;<br>gain = 0 dB to –30 dB                        | THD               | –    | 0,1  | –    | %    |
| for $V_{i(rms)} = 2,0$ V<br>gain = –4 dB to –30 dB                        | THD               | –    | 0,3  | –    | %    |
| Channel separation at 10 kHz  |                   |      |      |      |      |
| gain = 0 dB   | $\alpha_{cr}$     | –    | 75   | –    | dB   |
| Ripple rejection (gain = 0 dB;<br>bass and treble in linear position)     |                   |      |      |      |      |
| $f_{ripple} = 100$ Hz   | RR <sub>100</sub> | –    | 50   | –    | dB   |
| Crosstalk attenuation from logic  |                   |      |      |      |      |
| inputs to AF outputs (gain = 0 dB;<br>bass and treble in linear position) |                   |      |      |      |      |
|   | $\alpha_L$        | –    | 110  | –    | dB   |
| Crosstalk between any input/output  |                   |      |      |      |      |
| f = 100 Hz to 12,5 kHz  | $\alpha$          | 65   | 70   | –    | dB   |
| Crosstalk IN1/IN2   |                   |      |      |      |      |
| gain = 0 dB; $R_G = 0$  | $\alpha$          | 95   | 100  | –    | dB   |

Hi-fi stereo audio processor; I<sup>2</sup>C bus

## TDA8421

| PARAMETER  | SYMBOL     | MIN. | TYP. | MAX. | UNIT    |
|--|------------|------|------|------|---------|
| <b>Headphone channel (CH2)</b>                             |            |      |      |      |         |
| Control range  |            |      |      |      |         |
| maximum voltage gain (0 dB step)                           | $G_{max}$  | -1   | -    | -    | dB      |
| minimum voltage gain (-62 dB step)                         | $G_{min}$  | -57  | -    | -    | dB      |
| last position  | $G_{off}$  | -80  | -85  | -    | dB      |
| mute position  | $G_{mute}$ | -85  | -90  | -    | dB      |
| Resolution   | $G_{step}$ | -    | 2    | -    | dB/step |
| Gain difference between left and right AF channel (note 1) |            |      |      |      |         |
| gain from 0 dB to -40 dB                                   | $\Delta G$ | -    | -    | 0,5  | dB      |
| gain from -40 dB to -62 dB                                 | $\Delta G$ | -    | -    | 2    | dB      |

**Note to the AC characteristics**

1. Balance is realized via software by different volume settings in both channels.



Hi-fi stereo audio processor; I<sup>2</sup>C bus

TDA8421

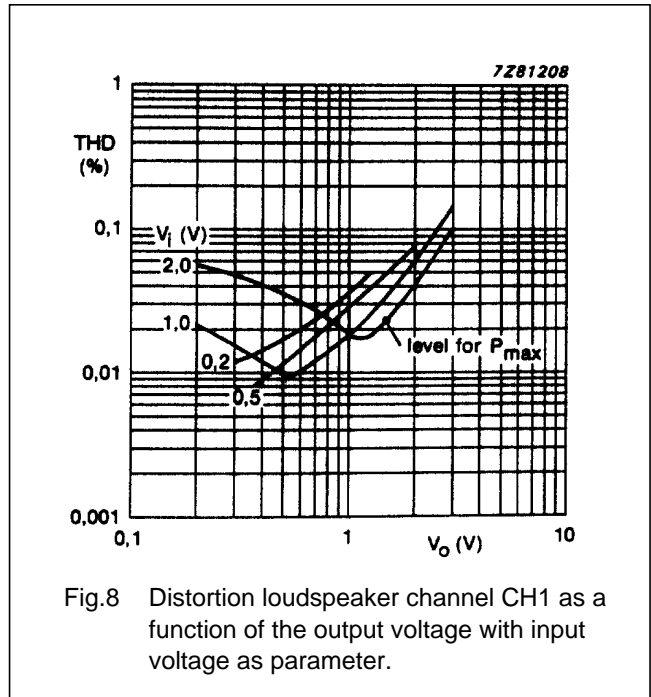
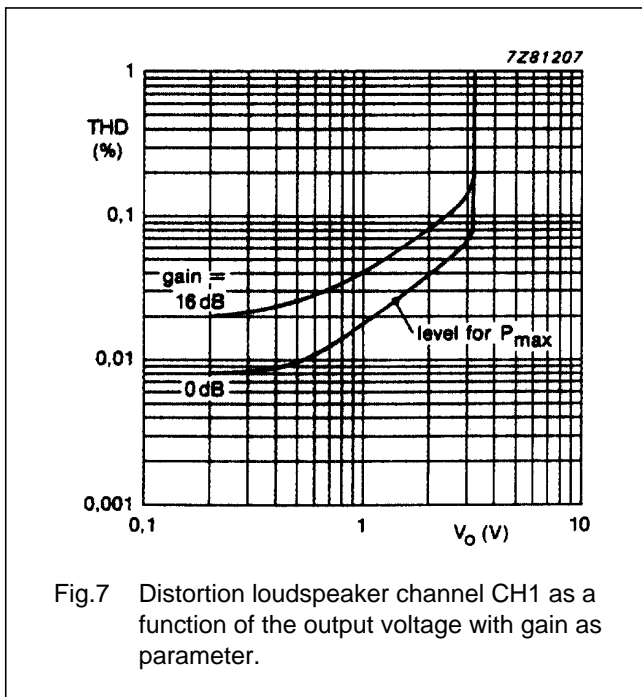
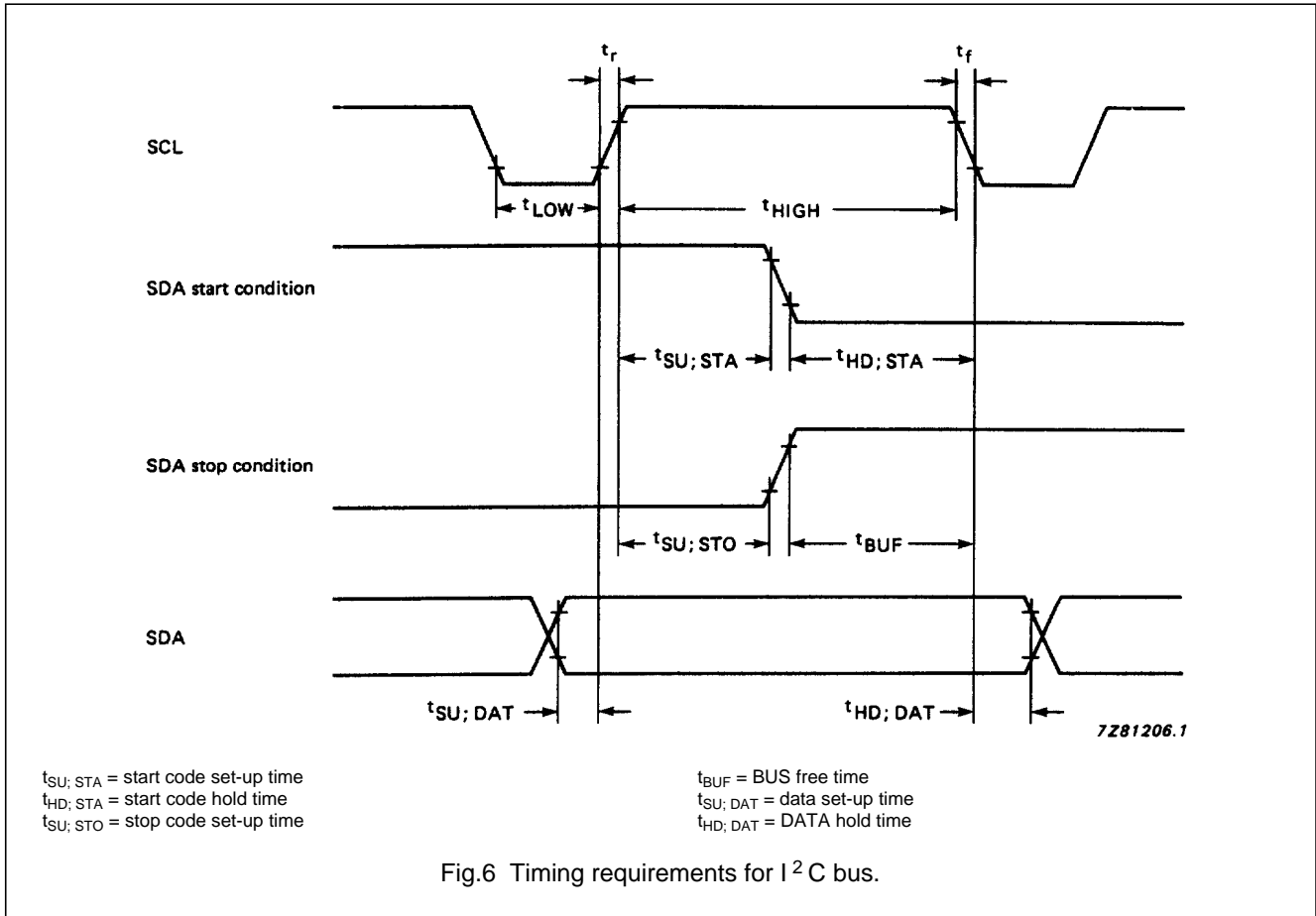

Hi-fi stereo audio processor; I<sup>2</sup>C bus

TDA8421

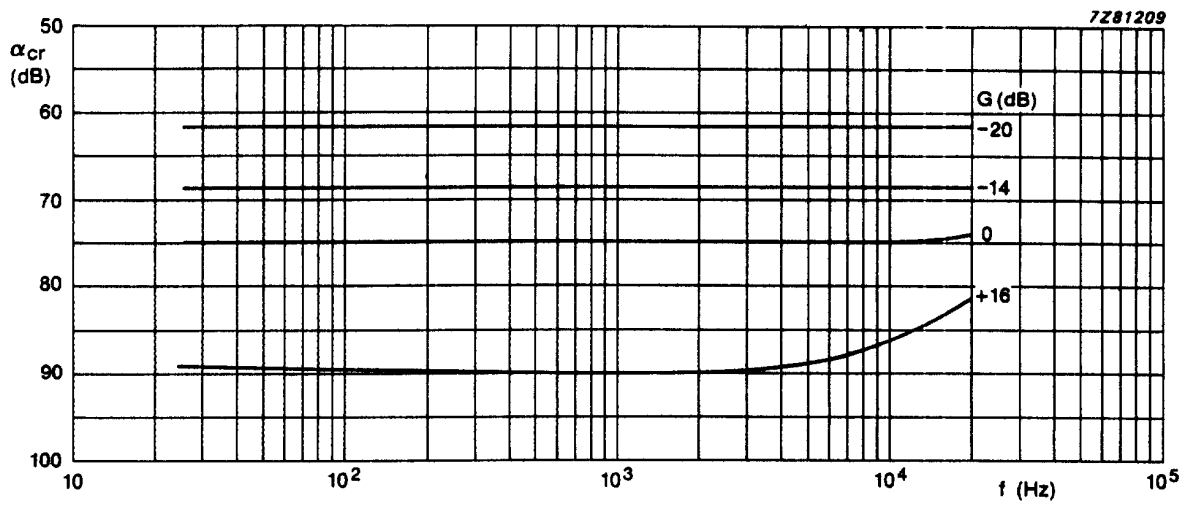

Fig.9 Channel separation loudspeaker channel CH1 as a function of frequency.

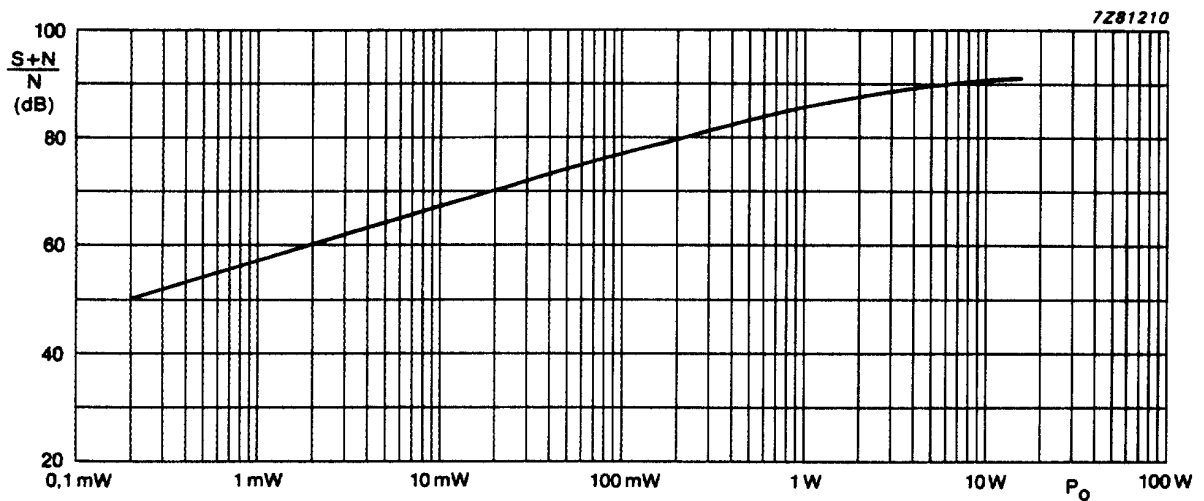

Fig.10 Signal-to-noise ratio as a function of output power.  
 Input voltage  $V_i = 0,5$  V; according to CCIR; quasi peak;  $P_o = 15$  W.

Hi-fi stereo audio processor; I<sup>2</sup>C bus

TDA8421

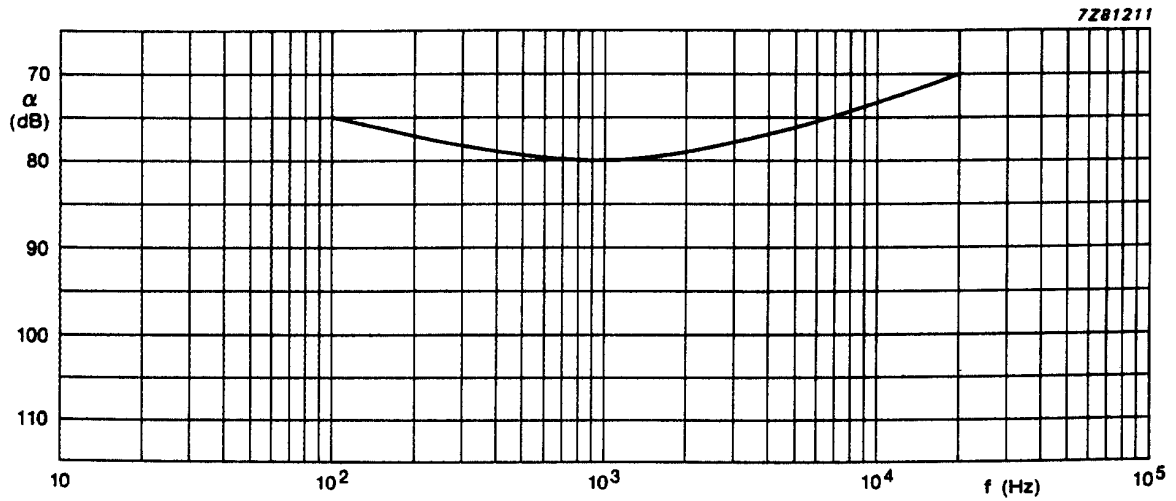

Fig.11 Crosstalk 2-tone mode as a function of frequency.  
 CH1: mode AA, Gain + 16 dB; CH2: mode BB, Gain 0 dB.  
 Signal input RIGHT; input LEFT to ground, measured at output CH1.

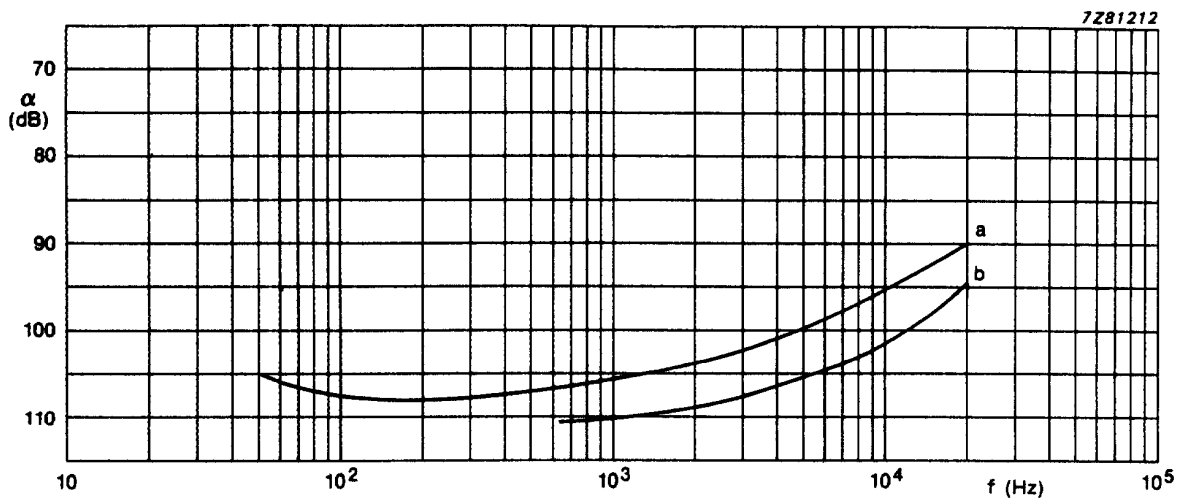

Fig.12 Crosstalk between IN1 and IN2 as a function of frequency; measured at output CH1;  $R_G = 0$ .  
 a) Gain = + 16 dB;  $V_i = 200$  mV. b) Gain = 0 dB;  $V_i = 1$  V.

Hi-fi stereo audio processor; I<sup>2</sup>C bus

TDA8421

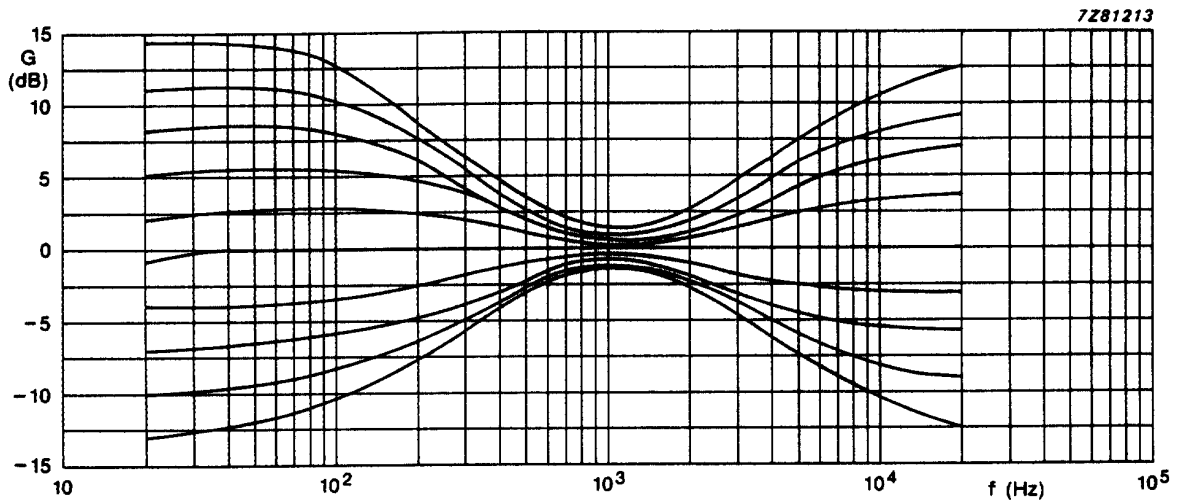

Fig.13 Bass and treble tone control.  $C_{bass} = 33 \text{ nF}$ ,  $C_{treble} = 5,6 \text{ nF}$ .

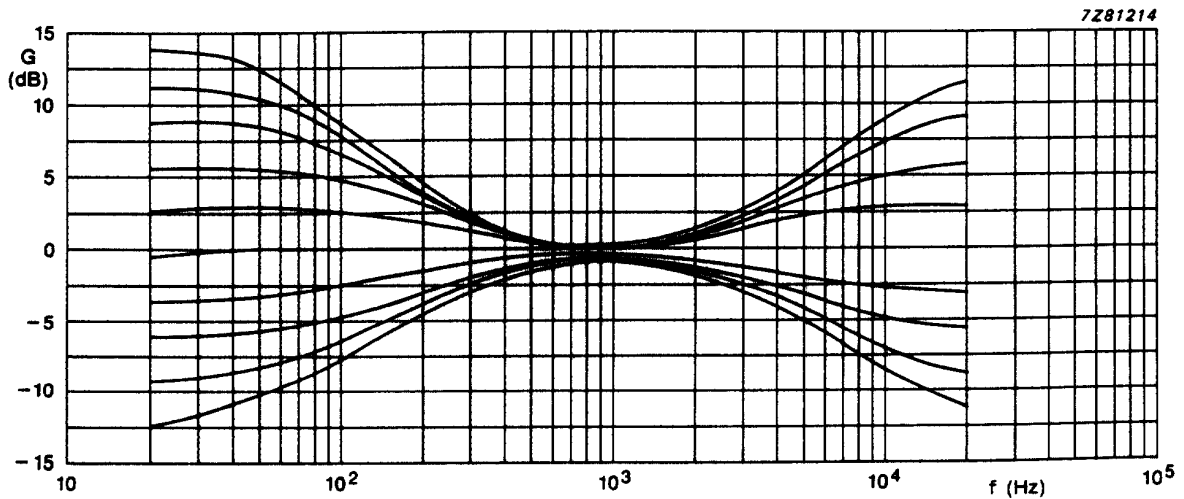
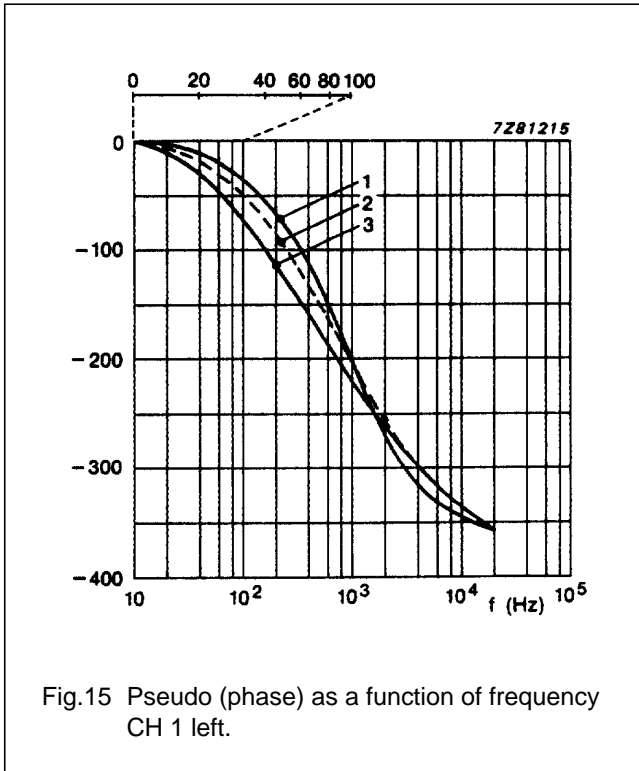

Fig.14 Bass and treble tone control.  $C_{bass} = 68 \text{ nF}$ ,  $C_{treble} = 3.9 \text{ nF}$ .

Hi-fi stereo audio processor; I<sup>2</sup>C bus

TDA8421



| CURVE | PIN 24 (nF) | PIN (nF) | EFFECT           |
|-------|-------------|----------|------------------|
| 1     | 15          | 15       | normal           |
| 2     | 5,6         | 47       | intensified      |
| 3     | 5,6         | 68       | more intensified |

Hi-fi stereo audio processor; I<sup>2</sup>C bus

TDA8421

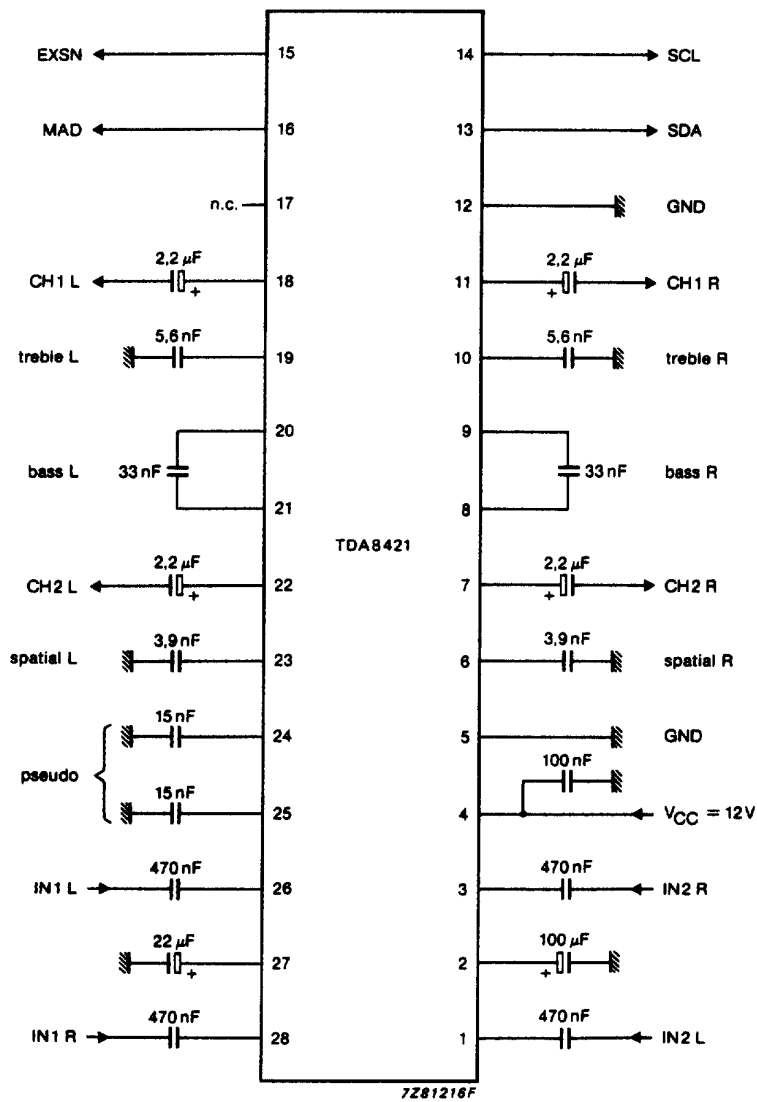

Fig.16 Test and application circuit diagram.

Hi-fi stereo audio processor; I<sup>2</sup>C bus

TDA8421

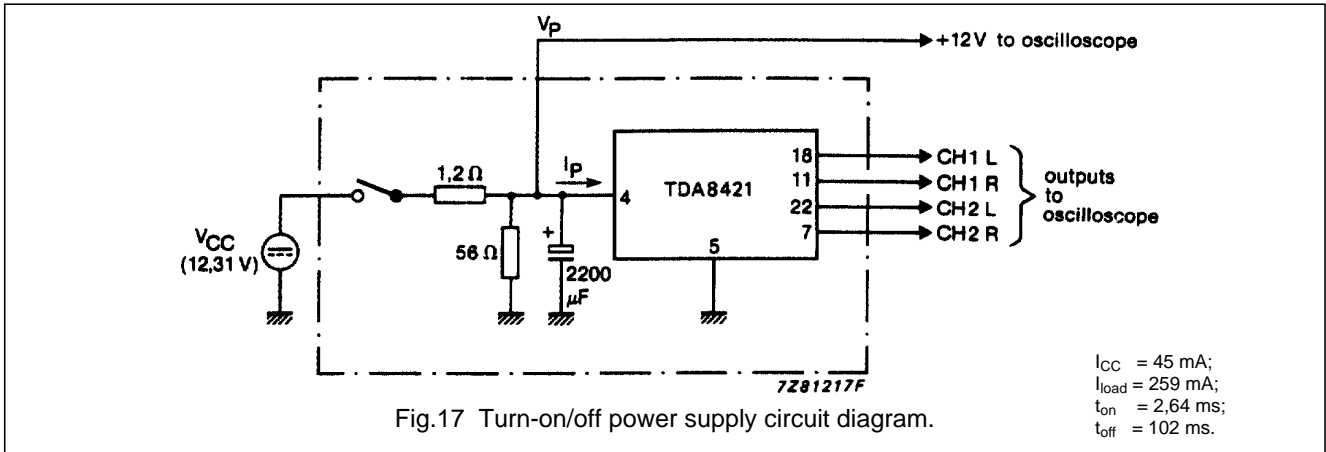

Fig.17 Turn-on/off power supply circuit diagram.

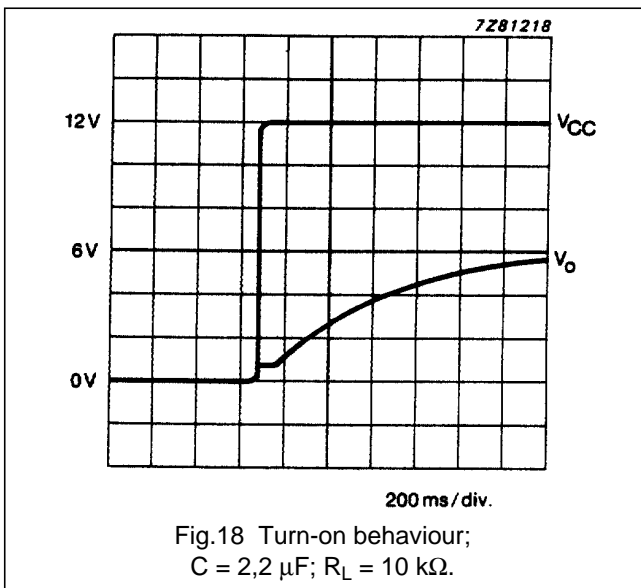

Fig.18 Turn-on behaviour;  
 $C = 2,2 \mu\text{F}; R_L = 10 \text{ k}\Omega.$

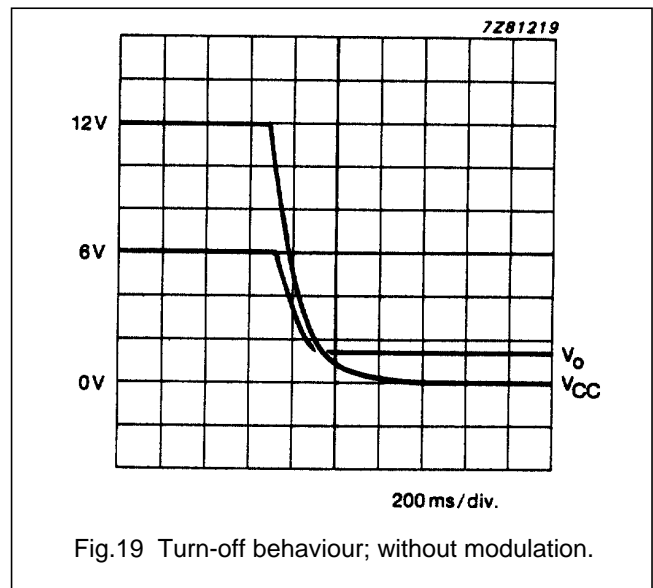

Fig.19 Turn-off behaviour; without modulation.

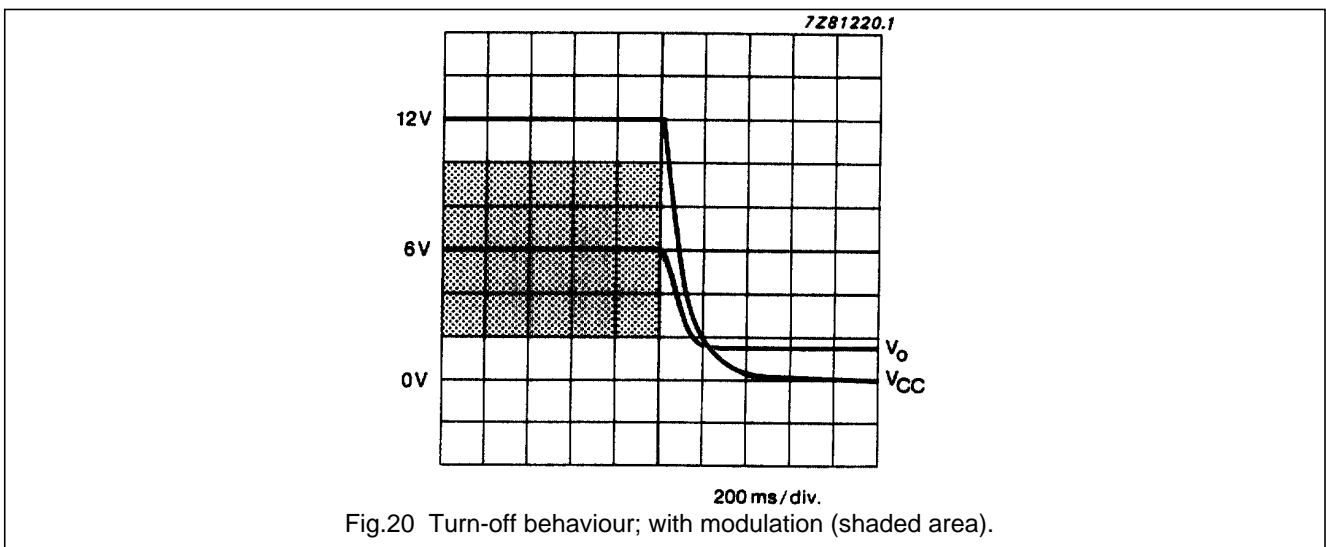

Fig.20 Turn-off behaviour; with modulation (shaded area).

Hi-fi stereo audio processor; I<sup>2</sup>C bus

TDA8421

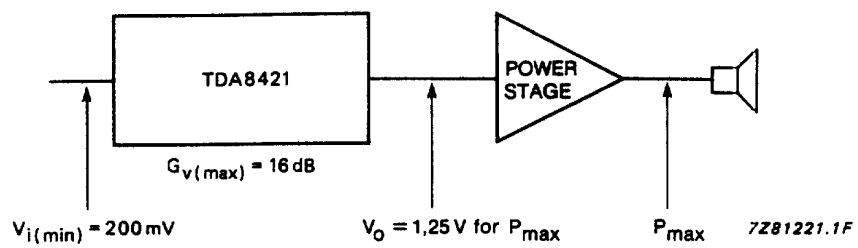

Fig.21 Level diagram loudspeaker channel CH1 with  $V_{i(\min)} = 200 \text{ mV}$ ;  $V_o = 1,25$  for  $P_{\max}$ .

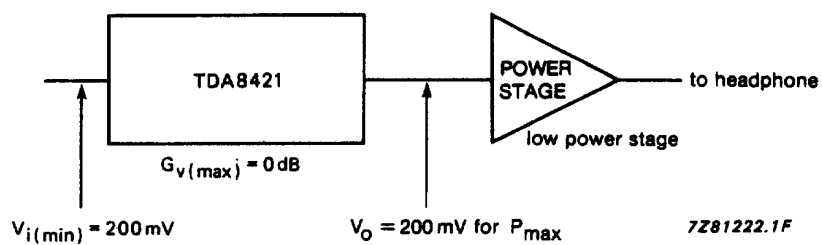

Fig.22 Level diagram headphone channel CH2 with  $V_i = 200 \text{ mV}$ ;  $V_o = 200 \text{ mV}$  for  $P_{\max}$ .



Hi-fi stereo audio processor; I<sup>2</sup>C bus

TDA8421

PACKAGE OUTLINE

DIP28: plastic dual in-line package; 28 leads (600 mil)

SOT117-1

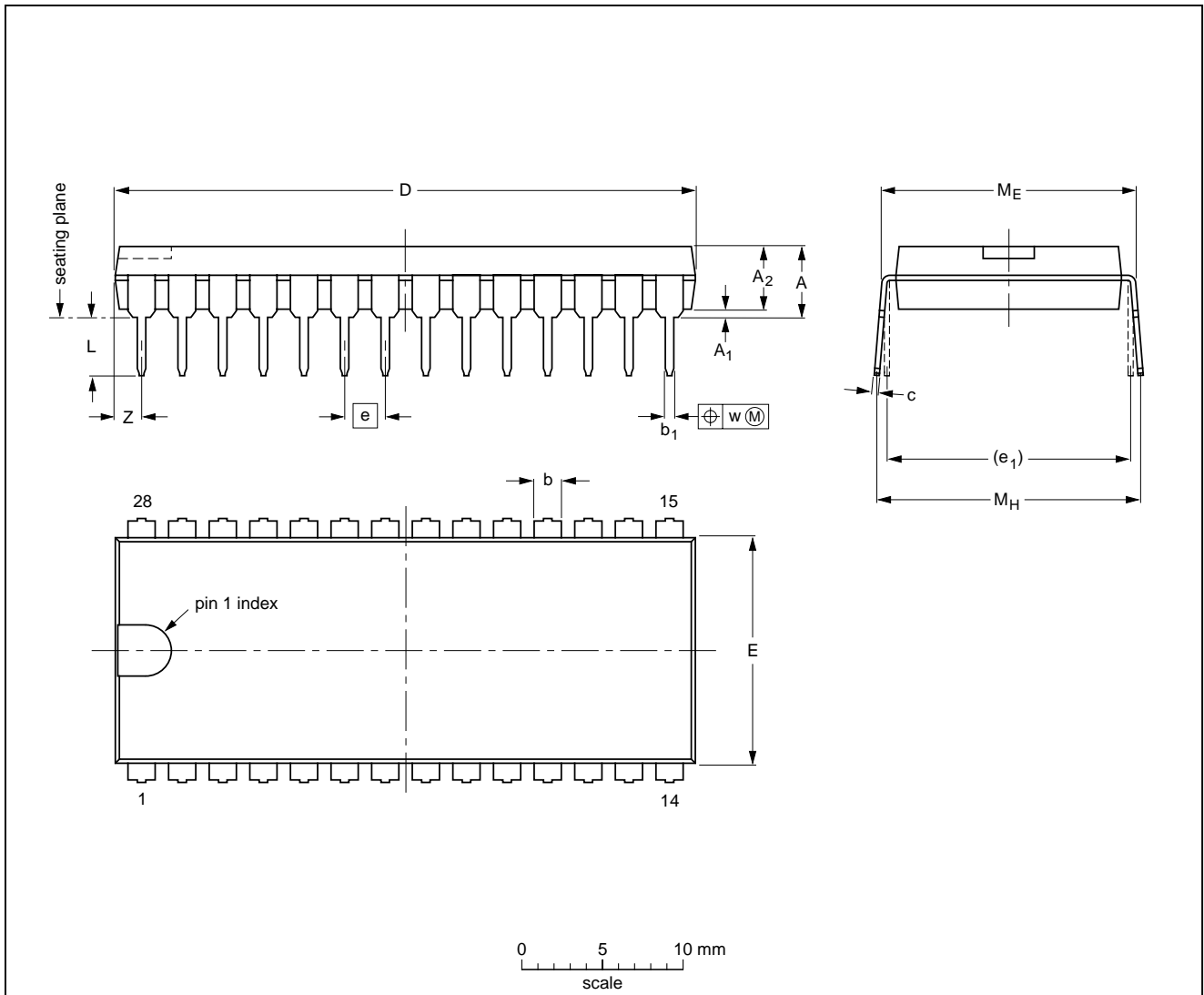

DIMENSIONS (inch dimensions are derived from the original mm dimensions)

| UNIT   | A max. | A <sub>1</sub> min. | A <sub>2</sub> max. | b              | b <sub>1</sub> | c              | D <sup>(1)</sup> | E <sup>(1)</sup> | e    | e <sub>1</sub> | L            | M <sub>E</sub> | M <sub>H</sub> | w    | Z <sup>(1)</sup> max. |
|--------|--------|---------------------|---------------------|----------------|----------------|----------------|------------------|------------------|------|----------------|--------------|----------------|----------------|------|-----------------------|
| mm     | 5.1    | 0.51                | 4.0                 | 1.7<br>1.3     | 0.53<br>0.38   | 0.32<br>0.23   | 36.0<br>35.0     | 14.1<br>13.7     | 2.54 | 15.24          | 3.9<br>3.4   | 15.80<br>15.24 | 17.15<br>15.90 | 0.25 | 1.7                   |
| inches | 0.20   | 0.020               | 0.16                | 0.066<br>0.051 | 0.020<br>0.014 | 0.013<br>0.009 | 1.41<br>1.34     | 0.56<br>0.54     | 0.10 | 0.60           | 0.15<br>0.13 | 0.62<br>0.60   | 0.68<br>0.63   | 0.01 | 0.067                 |

Note

1. Plastic or metal protrusions of 0.25 mm maximum per side are not included.

| OUTLINE VERSION | REFERENCES |          |      | EUROPEAN PROJECTION | ISSUE DATE           |
|-----------------|------------|----------|------|---------------------|----------------------|
|                 | IEC        | JEDEC    | EIAJ |                     |                      |
| SOT117-1        | 051G05     | MO-015AH |      |                     | 92-11-17<br>95-01-14 |

Hi-fi stereo audio processor; I<sup>2</sup>C bus

TDA8421

**SOLDERING****Introduction**

There is no soldering method that is ideal for all IC packages. Wave soldering is often preferred when through-hole and surface mounted components are mixed on one printed-circuit board. However, wave soldering is not always suitable for surface mounted ICs, or for printed-circuits with high population densities. In these situations reflow soldering is often used.

This text gives a very brief insight to a complex technology. A more in-depth account of soldering ICs can be found in our "IC Package Databook" (order code 9398 652 90011).

**Soldering by dipping or by wave**

The maximum permissible temperature of the solder is 260 °C; solder at this temperature must not be in contact

with the joint for more than 5 seconds. The total contact time of successive solder waves must not exceed 5 seconds.

The device may be mounted up to the seating plane, but the temperature of the plastic body must not exceed the specified maximum storage temperature ( $T_{stg\ max}$ ). If the printed-circuit board has been pre-heated, forced cooling may be necessary immediately after soldering to keep the temperature within the permissible limit.

**Repairing soldered joints**

Apply a low voltage soldering iron (less than 24 V) to the lead(s) of the package, below the seating plane or not more than 2 mm above it. If the temperature of the soldering iron bit is less than 300 °C it may remain in contact for up to 10 seconds. If the bit temperature is between 300 and 400 °C, contact may be up to 5 seconds.

**DEFINITIONS**

| <b>Data sheet status</b>  |   |
|---|---|
| Objective specification   | This data sheet contains target or goal specifications for product development.       |
| Preliminary specification   | This data sheet contains preliminary data; supplementary data may be published later. |
| Product specification   | This data sheet contains final product specifications.                                |
| <b>Limiting values</b>  |   |
| Limiting values given are in accordance with the Absolute Maximum Rating System (IEC 134). Stress above one or more of the limiting values may cause permanent damage to the device. These are stress ratings only and operation of the device at these or at any other conditions above those given in the Characteristics sections of the specification is not implied. Exposure to limiting values for extended periods may affect device reliability. |   |
| <b>Application information</b>  |   |
| Where application information is given, it is advisory and does not form part of the specification.   |   |

**LIFE SUPPORT APPLICATIONS**

These products are not designed for use in life support appliances, devices, or systems where malfunction of these products can reasonably be expected to result in personal injury. Philips customers using or selling these products for use in such applications do so at their own risk and agree to fully indemnify Philips for any damages resulting from such improper use or sale.

**PURCHASE OF PHILIPS I<sup>2</sup>C COMPONENTS**

Purchase of Philips I<sup>2</sup>C components conveys a license under the Philips' I<sup>2</sup>C patent to use the components in the I<sup>2</sup>C system provided the system conforms to the I<sup>2</sup>C specification defined by Philips. This specification can be ordered using the code 9398 393 40011.