

TOSHIBA BIPOLAR DIGITAL INTEGRATED CIRCUIT SILICON MONOLITHIC

TD6336F

8-BIT SERIAL-IN PARALLEL-OUT DRIVER

The TD6336F is an automotive 8-bit SI/PO driver IC using a Bi-CMOS process characterized by high output withstand voltage.

The shift registers share a common clock and a common reset signal. Data is shifted on the leading edge of the clock. The IC also has $\overline{\text{LATCH}}$ and ENABLE inputs. Its output is an N-channel open-drain output, and I_{sink} is up to 100mA. When the supply voltage becomes low, the output turns off.

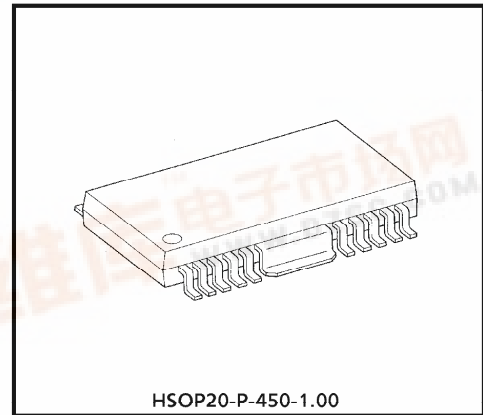

Weight : 0.79g (Typ.)

FEATURES

- Serial input and 8-stage parallel/serial output
- Serial output allows cascade expansion.
- ENABLE input for output control
- Large output current : 100mA (Max.)
- High output withstand voltage : 80V (Max.)
- Power detection circuit incorporated : The output is disabled when $V_{\text{DD}} < 3\text{V}$ (Typ).

BLOCK DIAGRAM AND PIN LAYOUT

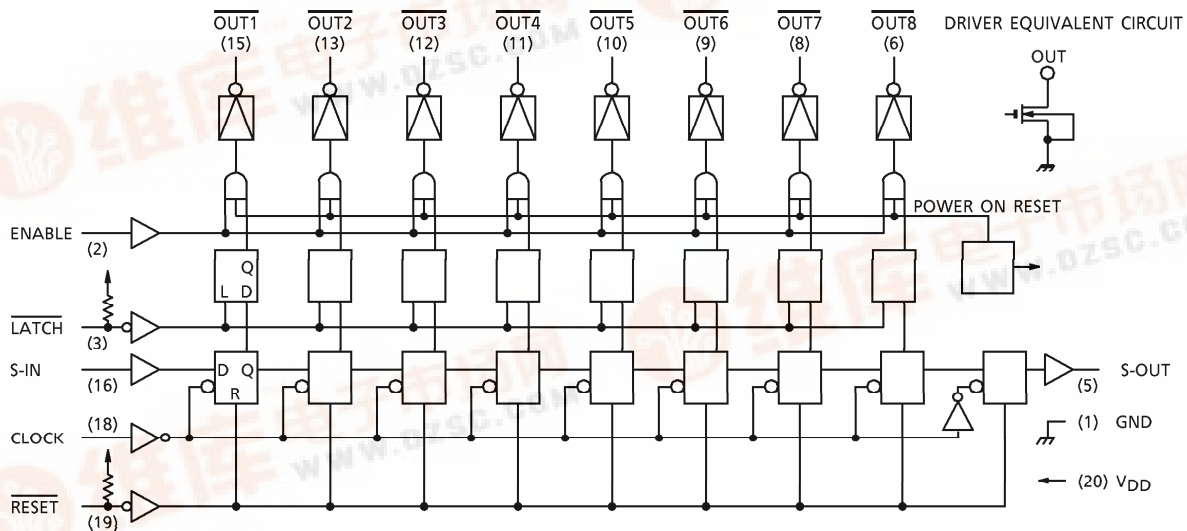

961001EBA2

- TOSHIBA is continually working to improve the quality and the reliability of its products. Nevertheless, semiconductor devices in general can malfunction or fail due to their inherent electrical sensitivity and vulnerability to physical stress. It is the responsibility of the buyer, when utilizing TOSHIBA products, to observe standards of safety, and to avoid situations in which a malfunction or failure of a TOSHIBA product could cause loss of human life, bodily injury or damage to property. In developing your designs, please ensure that TOSHIBA products are used within specified operating ranges as set forth in the most recent products specifications. Also, please keep in mind the precautions and conditions set forth in the TOSHIBA Semiconductor Reliability Handbook.
- The products described in this document are subject to foreign exchange and foreign trade control laws.
- The information contained herein is presented only as a guide for the applications of our products. No responsibility is assumed by TOSHIBA CORPORATION for any infringements of intellectual property or other rights of the third parties which may result from its use. No license is granted by implication or otherwise under any intellectual property or other rights of TOSHIBA CORPORATION or others.
- The information contained herein is subject to change without notice.



PIN DESCRIPTION

PIN No.	SYMBOL	DESCRIPTION
1	GND	Grounded. Must be connected to the FIN pin.
2	ENABLE	Data is output when this signal is high ; all output buffers turn off when the signal goes low.
3	$\overline{\text{LATCH}}$	Data is held when this signal is low ; data is rewritten when the signal goes high. When the pin is open, the signal is high.
5	S-OUT	Serial output pin allowing easy bit addition. To prevent malfunction, this pin has a function for a half-bit delay output.
6 ~15	$\overline{\text{OUT8}}$ $\sim\overline{\text{OUT1}}$	Supplies shift register data or latch data. The signal is an N-channel MOS open-drain output.
16	S-IN	Serial data input pin.
18	CLOCK	Clock input pin for shift registers. The register acts at the leading edge of the clock.
19	$\overline{\text{RESET}}$	Clears data in the shift registers. The shift registers do not change when this signal is high ; they are reset when the signal goes low. When the pin is open, the signal is high.
20	V _{DD}	Power supply pin.
4, 7, 14, 17	NC	Not connected.
FIN	GND	Ground pin serving also as a heat sink. This pin must be connected to pin 1.

TRUTH TABLE

CK	E	$\overline{\text{R}}$	$\overline{\text{LATCH}}$	S-IN	OUT		S-OUT	CK = CLOCK E = ENABLE $\overline{\text{R}}$ = $\overline{\text{RESET}}$ S-IN = SERIAL IN OUT-PARALLEL OUT S-OUT = SERIAL OUT * = DON'T CARE
					$\overline{\text{Q1}}$	$\overline{\text{Qn}}$		
	H	H	H	L	OFF	$\overline{\text{Qn-1}}$	Q7	
	H	H	H	H	ON	$\overline{\text{Qn-1}}$	Q7	
	H	H	L	*	NC	NC	Q7	
	L	H	*	*	NC	NC	Q7	
	*	*	*	*	NC	NC	Q7	
*	*	L	H	*	OFF	OFF	L	
*	H		L	*	NC	NC	L	

TIMING CHART

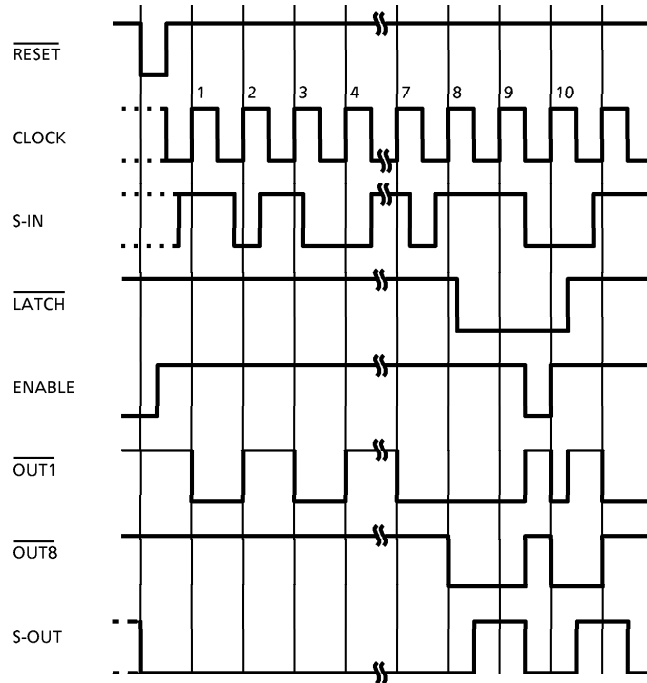

MAXIMUM RATINGS (Ta = 25°C)

CHARACTERISTIC	SYMBOL	RATING	UNIT
Supply Voltage	V _{DD}	- 0.3~7	V
Input Voltage	V _{IN}	- 0.3~V _{DD} + 0.3	V
Output Voltage	V _{OUT1} (Note 1)	- 0.3~V _{DD} + 0.3	V
	V _{OUT2} (Note 2)	- 0.3~80	
Output Current	I _{OUT}	100	mA
Power Dissipation	P _D	1.0	W
Storage Temperature	T _{stg}	- 55~150	°C
Lead Temperature-time	T _{sol}	260 (10s)	°C

PIN CONFIGURATION

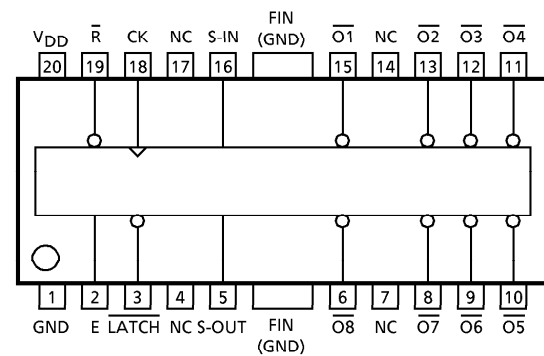

(Note 1) S-OUT
 (Note 2) $\overline{\text{OUT1}} \sim \overline{\text{OUT8}}$

RECOMMENDED OPERATING CONDITIONS (Ta = -40~105°C)

CHARACTERISTIC			SYMBOL	TEST CIRCUIT	TEST CONDITION	MIN.	TYP.	MAX.	UNIT
Supply Voltage			V _{DD}	—	—	4	5.0	6	V
Input Voltage			V _{IN}	—	—	0	—	V _{DD}	V
Output Current	High	S-OUT	I _{OH}	—	—	0	—	-1.0	mA
	High	\overline{Qn}	V _{OH}	—	—	0	—	60	V
Output Current	Low	S-OUT	I _{OL}	—	—	0	—	1.0	mA
		\overline{Qn}	I _{OL}	—	—	0	—	70	mA
Clock Frequency			f clock	—	—	0	—	1.0	MHz
Clock Pulse Width			tw clock	—	—	500	—	—	ns
Data Setup Time			t _{setup}	—	—	500	—	—	ns
Data Hold Time			t _{hold}	—	—	500	—	—	ns
Maximum Clock Time	Rise Time		t _r	—	—	—	—	70	μs
	Fall Time		t _f					70	μs

ELECTRICAL CHARACTERISTICS (Ta = -40~105°C, V_{DD} = 4~6V)

CHARACTERISTIC			SYMBOL	TEST CIRCUIT	TEST CONDITION	MIN.	TYP.	MAX.	UNIT
Input Voltage	High		V _{IH}	—	—	0.8 × V _{DD}	—	—	V
	Low		V _{IL}	—	—	—	—	0.2 × V _{DD}	
Input Current	R, LATCH		I _{IN}	—	V _{IN} = 0~V _{DD}	—	—	±100	μA
	CK, S-IN, E		I _{IN}	—	V _{IN} = 0~V _{DD}	—	—	±1	
Output Voltage	High	S-OUT	V _{OH}	—	I _{OH} = -1mA	V _{DD} - 0.4	—	—	V
Output Current	High	\overline{Qn}	I _{OH}	—	V _{OH} = 80V	—	—	100	μA
Output Voltage	Low	S-OUT	V _{OL}	—	I _{OL} = 1mA	—	—	0.4	V
		\overline{Qn}	V _{OL}	—	Ta = 25°C, I _{OL} = 100mA	—	—	1.2	V
Static Current Consumption			I _{DD} (1)	—	V _{DD} = 5V, f = 0Hz	—	—	1	mA
Dynamic Current Consumption			I _{DD} (2)	—	V _{DD} = 5V, f = 1MHz	—	—	5	mA

SWITCHING CHARACTERISTICS (Ta = -40~105°C, VDD = 4~6V)

CHARACTERISTIC		SYMBOL	TEST CIRCUIT	TEST CONDITION	MIN.	TYP.	MAX.	UNIT
Delay Time	High	CK-S-OUT	—	RL S-OUT = 2kΩ RL Qn = 150Ω CL = 15pF VIH = 3.0V, VIL = 0V Duty = 50%	—	0.1	0.5	μs
		CK-Qn			—	0.5	2.5	
	Low	CK-S-OUT			—	0.1	0.5	
		CK-Qn			—	0.3	1.5	
Maximum Clock Frequency		fmax	—		—	10	—	MHz
Maximum Data Setup Time		tsetup	—		—	5	25	ns
Minimum Data Hold Time		t hold	—		—	5	25	ns
Maximum Clock Time	Rise Time	tr	—		—	70	—	μs
	Fall Time	tf	—	—	70	—		

CL : Includes the capacitances of the measuring instrument and probe.

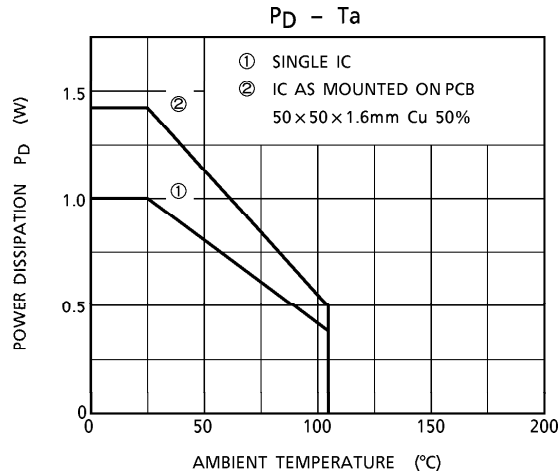

OUTLINE DRAWING
HSOP20-P-450-1.00

Unit : mm

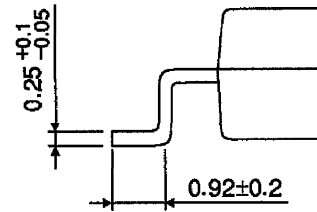
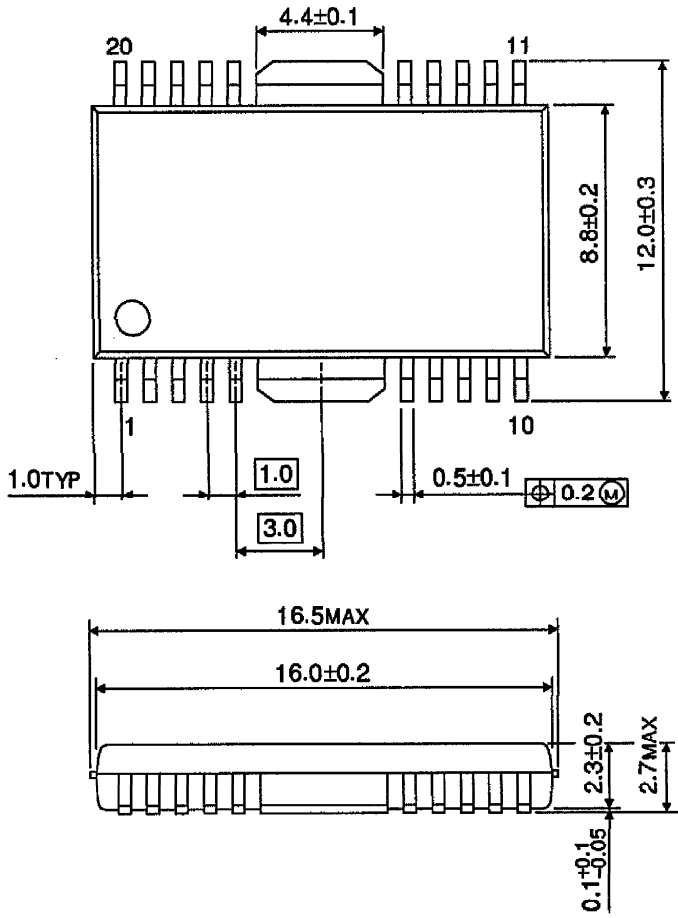

Weight : 0.79g (Typ.)