

VI TELEFILTER **Filter Specification** **TFS 208C** **1/5**

Measurement condition

Ambient temperature T_A : 23 °C
 Input power level: 0 dBm
 Terminating impedances at f_c :
 input: 540 Ω || -5.88 pF
 output: 578 Ω || -6.6 pF

Characteristics

Remark:
 Reference level for the relative attenuation a_{rel} of the **TFS 208C** is the maximum of the pass band attenuation a_{max} . The maximum of the pass band attenuation a_{max} is defined as the insertion loss a_e . The centre frequency f_c is the arithmetic mean value of the upper and lower frequencies at the 1 dB filter attenuation level relative to the insertion loss a_e . The nominal frequency f_N is fixed on **208 MHz** without tolerance. The given values for the relative attenuation a_{rel} and for the group delay ripple have to be reached at the frequencies given below also if the centre frequency f_c is shifted due to the temperature coefficient of frequency TC_f in the operating temperature range and due to a production tolerance for the centre frequency f_c .

Data	typ. value	tolerance / limit
Insertion loss (Reference level) a_e		max. 7,0 dB min. 5,0 dB
Nominal frequency f_N	-	208,0 MHz
Centre frequency f_c	208,0 MHz	
Passband width		min. 300,0 kHz
Relative attenuation a_{rel}		
$f_N \dots$	$f_N \pm 0,15$ MHz	- max. 1,25 dB
$f_N \pm 0,4$ MHz	$f_N \pm 0,6$ MHz	- min. 2,0 dB
$f_N \pm 0,6$ MHz	$f_N \pm 1,2$ MHz	- min. 8,0 dB
$f_N \pm 1,2$ MHz	$f_N \pm 1,8$ MHz	- min. 20,0 dB
$f_N \pm 1,8$ MHz	$f_N \pm 3,4$ MHz	- min. 25,0 dB
$f_N \pm 3,4$ MHz	$f_N \pm 9,5$ MHz	- min 30,0 dB
$f_N \pm 9,5$ MHz	$f_N \pm 13$ MHz	- min 43,0 dB
$f_N \pm 13$ MHz	$f_N + 450$ MHz	- min 55,0 dB
Group delay *)		max 1,7 μ s min. 0,7 μ s
Group delay rippel *)within ± 150 kHz		max. 150,0 ns
VSWR:		max. 2,3: 1
IP3 **)		min. 60,0 dB
Operating temperature range		- 10 °C ... + 85 °C
Temperature coefficient of frequency (TC_f) ***)		-0,029 ppm/ K ²
Frequency inversion temperature T_o		30 C °
Input power level:		max. 10,0 dBm

*) measured with smoothing; smoothing aperture ≤ 30 KHz
 **) modulation signals: f_N and $f_N - 28$ MHz each of 10 dBm
 ***) $\Delta f_c(\text{Hz}) = TC_f(\text{ppm/K}^2) \times (T_o - T_A)^2 \times f_{T_O}(\text{MHz})$
 f_{T_O} is reference frequency f_c at frequency inversion temperature (T_o)

Generated: Sabah

Checked/Approved:

VI TELEFILTER
 Potsdamer Straße 18
 D 14 513 TELTOW / Germany
 Tel: (+49) 3328 4784-0 / Fax: (+49) 3328 4784-30
 E-Mail: tft@telefilter.com

Vectron International, Inc.
 267 Lowell Road
 Hudson, NH 03051 / USA
 Tel: (603) 598-0070 Fax: (603) 598-0075
 E-Mail: vti@vtinh.com



VI TELEFILTER**Filter Specification****TFS 208C****2/5****Construction and pin connection**

(All dimensions in mm)

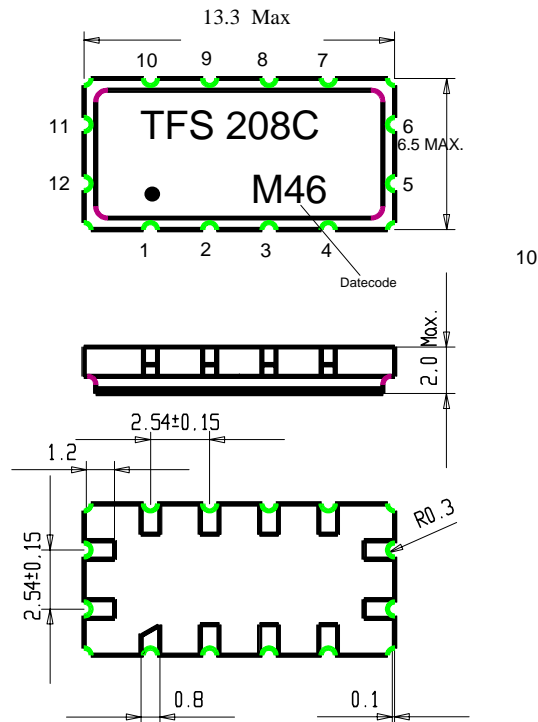

1	Ground
2	Ground
3	Ground
4	Ground
5	Output
6	Output RF Return
7	Ground
8	Ground
9	Ground
10	Ground
11	Input
12	Input RF Return

Date code: Year+week

K 1998

L 1999

M 2000

N 2001

.....

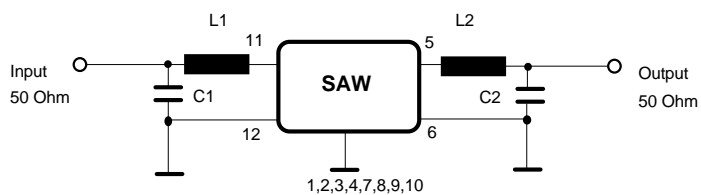
50 Ω matching network:**VI TELEFILTER**

Potsdamer Straße 18

D 14 513 TELTOW / Germany

Tel: (+49) 3328 4784-0 / Fax: (+49) 3328 4784-30

E-Mail: tft@telefilter.com

Vectron International, Inc.

267 Lowell Road

Hudson, NH 03051 / USA

Tel: (603) 598-0070 Fax: (603) 598-0075

E-Mail: vti@vtinh.com

VI TELEFILTER**Filter Specification****TFS 208C****3/5****Stability characteristics**

After the following tests the filter shall meet the whole specification:

1. Shock: 500g, 18 ms, half sine wave, 3 shocks each plane;
DIN IEC 68 T2 - 27
2. Vibration: 10 Hz to 500 Hz, 0,35 mm or 5g respectively, 1 octave per min, 10 cycles per plan, 3 plans;
DIN IEC 68 T2 - 6
3. Damp heat: 25 °C to 55°C / 95% r.H. / 10 cycles
(cycle) DIN IEC 68 - 2 – 30 Db
4. Resistance to solder heat (reflow): max. 2 times reflow process;
for temperature conditions refer to the attached "Air reflow temperature conditions" on page 4;

Packing

Tape & Reel: IEC 286 - 3, with exception of value for N and minimum bending radius;
tape type II, embossed carrier tape with top cover tape on the upper side;
max. pieces of filters per reel: 1700
Reel of empty components at start: min 300 mm
Reel of empty components at start including leader: min 500 mm
Trailer min 300 mm

Tape (all dimensions in mm)

W : 24 ± 0,3
Po : 4 ± 0,1
Do : 1,5 ± 0,1
E : 1,75 ± 0,1
F : 11,5 ± 0,1
G (min) : 0,60
P2 : 2 ± 0,1
P1 : 12 ± 0,1
D1(min) : 1,5
Ao : 7,1 ± 0,2
Bo : 13,9 ± 0,2
CT : 21,5 ± 0,1

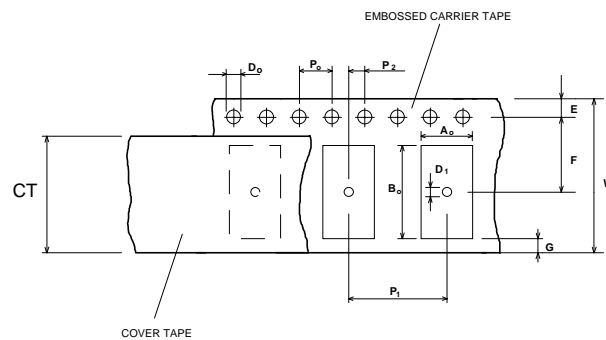
**Reel (all dimensions in mm):**

A : 330
W1 : 24,40 +2,0
W2 (max) : 30,4
N (min) : 60
C : 13 ± 0,5 / -0,2

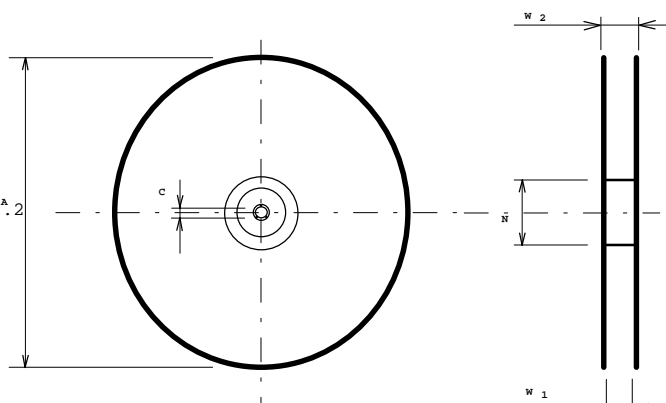

The minimum bending radius is 45 mm. The mounting surface of the filters faces the bottom side of the embossed carrier tape. The marking of the filters is able to read if the view is directed on the upper side of the carrier tape with the sprocket holes on the left side of the tape.

VI TELEFILTER

Potsdamer Straße 18
D 14 513 TELTOW / Germany
Tel: (+49) 3328 4784-0 / Fax: (+49) 3328 4784-30
E-Mail: tft@telefilter.com

Vectron International, Inc.

267 Lowell Road
Hudson, NH 03051 / USA
Tel: (603) 598-0070 Fax: (603) 598-0075
E-Mail: vti@vtinh.com

VI TELEFILTER**Filter Specification****TFS 208C****4/5****Air reflow temperature conditions**

1st and 2nd air reflow profile

Name:	pre-heating periods	main-heating periods	peak temperature
Temperature:	150 °C - 170 °C	over 200 °C	255 °C ± 5 °C
Time:	60 sec. - 90 sec.	20 sec. - 25 sec.	

Chip-mount air reflow profile

Table for temperature vs. time during the air reflow process

Tolerance of temperatures: ± 5 °C

time / sec.	temperature / °C	time / sec.	temperature / °C
0	23	140	160
10	34	150	161
20	46	160	164
30	60	170	170
40	80	180	180
50	103	190	205
60	121	195	230
70	134	200	255
80	143	205	230
90	150	210	205
100	154	215	180
110	156	220	165
120	158	230	140
130	159	240	120

History

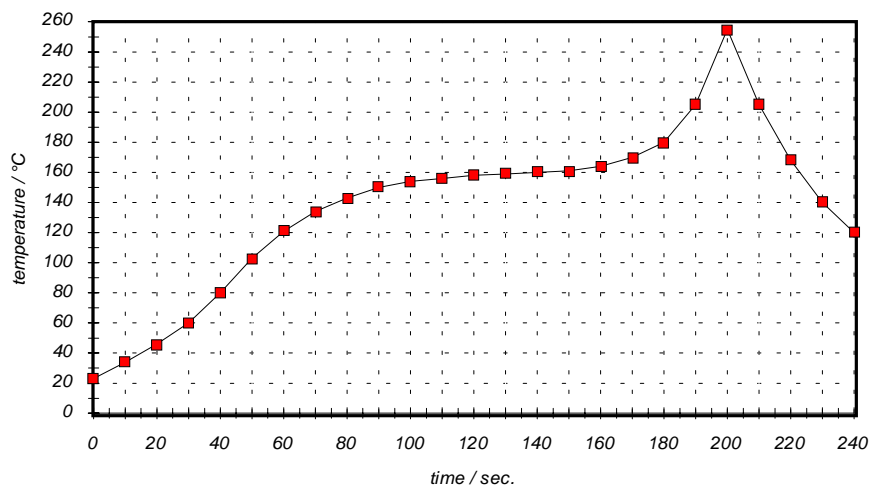
VI TELEFILTER
 Potsdamer Straße 18
 D 14 513 TELTOW / Germany
 Tel: (+49) 3328 4784-0 / Fax: (+49) 3328 4784-30
 E-Mail: tft@telefilter.com

Vectron International, Inc.
 267 Lowell Road
 Hudson, NH 03051 / USA
 Tel: (603) 598-0070 Fax: (603) 598-0075
 E-Mail: vti@vtinh.com

VI TELEFILTER	Filter Specification	TFS 208C	5/5
----------------------	-----------------------------	-----------------	------------

Version	Reason of Changes	Name	Date
1.0	- generation of specification according to hudson specification	Sabah	07.10.1999
1.1	- correction according to customer specification (Nokia) - IP3: instead of 'No statement' is ≥ 60 dBm - VSWR (max): instead of $\leq 2.0:1$ is $\leq 2.3:1$ - Rejection ($f \geq f_N \pm 13000$ KHz): instead of min. 60 dB is min. 55 dB - Operational temperature range changed from -10 80 °C to -10 85 °C	Sabah	27.03.2000
1.2	- The sprocket holes: instead of the right side of the tape is on the left side of the tape (according to customer requirement, e mail from: 7. Juli.00)	Sabah	12.07.2000

VI TELEFILTER
 Potsdamer Straße 18
 D 14 513 TELTOW / Germany
 Tel: (+49) 3328 4784-0 / Fax: (+49) 3328 4784-30
 E-Mail: tft@telefilter.com

Vectron International, Inc.
 267 Lowell Road
 Hudson, NH 03051 / USA
 Tel: (603) 598-0070 Fax: (603) 598-0075
 E-Mail: vti@vtinh.com