

VI TELEFILTER

SAW Filter Specification

TFS 400 C2

Measurement condition

Ambient temperature: 23 °C
 Input power level: 0 dBm
 Terminating impedances
 for input: 500 Ω // -1 pF
 for output: 500 Ω // -1 pF

Characteristics

Remark:

Reference level for the relative attenuation a_{rel} of the TFS 400 C2 is the minimum of the pass band attenuation a_{min} . The minimum of the pass band attenuation a_{min} is defined as the insertion loss a_e . The centre frequency f_0 is the arithmetic mean value of the upper and lower frequencies at the 3 dB filter attenuation level relative to the insertion loss a_e . The nominal frequency f_N is fixed on 400 MHz without tolerance. The given values for the relative attenuation a_{rel} and for the group delay ripple have to be reached at the frequencies given below also if the centre frequency f_0 is shifted due to the temperature coefficient of frequency TC_f in the operating temperature range and due to a production tolerance for the centre frequency f_0 .

D a t a		typ. value	tolerance/limit
Insertion loss (Reference level)	$a_e = a_{min}$	-	max. 6,5 dB
Nominal frequency	f_N	-	400,000 MHz
Guaranteed 1,5 dB signal band width	BW	-	min. 160 kHz
Relative attenuation $f_N \pm 80$ kHz	a_{rel}	-	max. 1,5 dB
$f_N \pm 200$ kHz		-	min. 2 dB
$f_N \pm 400$ kHz ... $f_N \pm 600$ kHz		-	min. 25 dB
$f_N \pm 600$ kHz ... $f_N \pm 1$ MHz		-	min. 40 dB
$f_N \pm 1$ MHz ... $f_N \pm 3$ MHz		-	min. 45 dB
$f_N \pm 3$ MHz		-	min. 55 dB
Group delay ripple $f_N \pm 90$ kHz	GD	-	max. 1,5 µs
Operating temperature range		- 10 °C ... + 55 °C	
Temperature coefficient of frequency	TC	ca. - 0.036 ppm/K ²	
Frequency inversion temperature		+ 20 °C	
Input power level		-	max. 10 dBm

Generated: _____

Checked / approved: _____

Construction, pin configuration and 50 Ω - matching network

(All dimensions in mm)

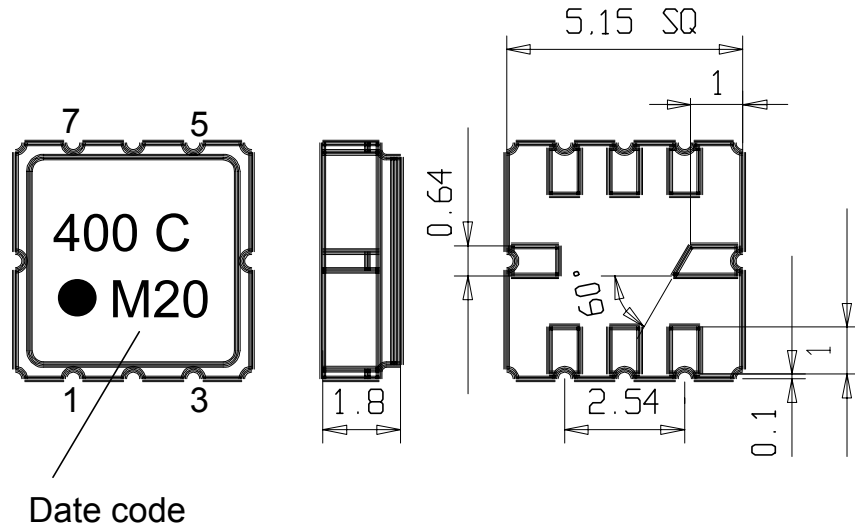

Pin 1 Sym. Output
 Pin 2 Sym. Output
 Pin 3 External Coil
 Pin 4,8 Package Ground

Pin 5 Sym. Input
 Pin 6 Sym. Input
 Pin 7 Ground

Date code: Year + week
 K 1998
 L 1999
 M 2000
 ...

50 Ohm Test circuit 1

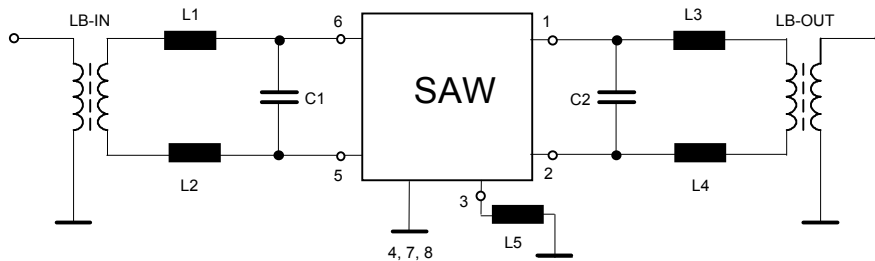

50 Ohm Test circuit 2

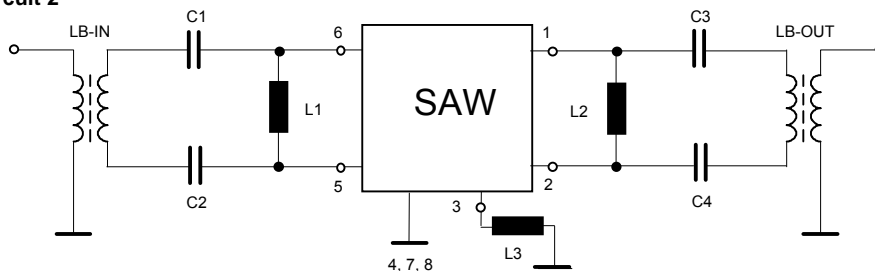

VI TELEFILTER**SAW Filter Specification****TFS 400 C2****3/5****Stability Characteristics**

After the following tests the filter shall meet the whole specification:

1. Shock: 500g, 18 ms, half sine wave, 3 shocks each plane;
DIN IEC 68 T2 - 27
2. Vibration: 10 Hz to 500 Hz, 0,35 mm or 5g respectively, 1 octave per min, 10 cycles per plan, 3 plans;
DIN IEC 68 T2 - 6
3. Damp heat: 25 °C to 55°C / 95% r.H. / 10 cycles
(cycle) DIN IEC 68 - 2 – 30 Db
4. Resistance to solder heat (reflow): max. 2 times reflow process;
for temperature conditions refer to the attached "Air reflow temperature conditions" on page 4;

Packing

Tape & Reel: IEC 286 - 3, with exception of value for N and minimum bending radius;
tape type II, embossed carrier tape with top cover tape on the upper side;

max. pieces of filters per reel: 3000
Reel of empty components at start: min 300 mm
Reel of empty components at start including leader: min 500 mm
Trailer: min 300 mm

Tape (all dimensions in mm)

W	: 12 ± 0,3
Po	: 4 ± 0,1
Do	: 1,5 ± 0,1
E	: 1,75 ± 0,1
F	: 5,5 ± 0,05
G (min)	: 0,75
P2	: 2 ± 0,05
P1	: 8 ± 0,1
D1(min)	: 1,5
Ao	: 5,3 ± 0,1
Bo	: 5,3 ± 0,1
CT	: 9,5 ± 0,1

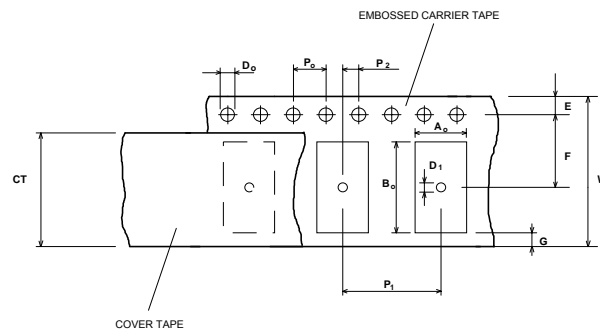
**Reel (all dimensions in mm):**

A	:	330
W1	:	12,4 + 0,2
W2 (max)	:	18,4
N (min)	:	50
C	:	13 ± 0,2

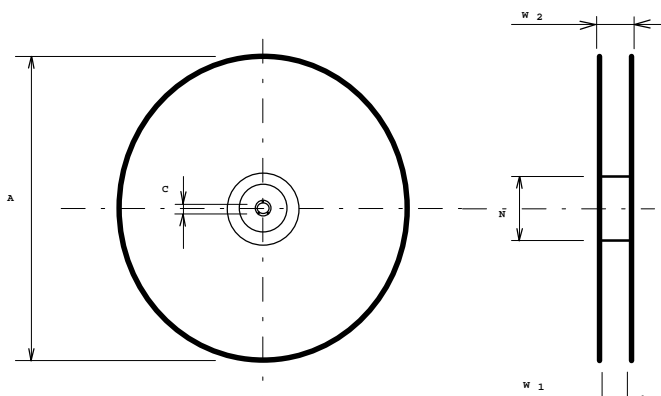

The minimum bending radius is 45 mm. The mounting surface of the filters faces the bottom side of the embossed carrier tape. The marking of the filters is able to read if the view is directed on the upper side of the carrier tape with the sprocket holes on the right side of the tape.

VI TELEFILTER
Potsdamer Straße 18
D 14 513 TELTOW / Germany
Tel: (+49) 3328 4784-52 / Fax: (+49) 3328 4784-30
E-Mail: tft@telefilter.com

Vectron International Inc.
267 Lowell Road
Hudson, NH 03051 / USA
Tel: (603) 598-0070 Fax: (603) 598-0075
E-Mail: vti@vtinh.com

Air reflow temperature conditions

1st and 2nd air reflow profile

Name:	pre-heating periods	main-heating periods	peak temperature
Temperature:	150 °C - 170 °C	over 200 °C	255 °C ± 5 °C
Time:	60 sec. - 90 sec.	20 sec. - 25 sec.	

Chip-mount air reflow profile

Table for temperature vs. time during the air reflow process

Tolerance of temperatures: ± 5 °C

time / sec.	temperature / °C	time / sec.	temperature / °C
0	23	140	160
10	34	150	161
20	46	160	164
30	60	170	170
40	80	180	180
50	103	190	205
60	121	195	230
70	134	200	255
80	143	205	230
90	150	210	205
100	154	215	180
110	156	220	165
120	158	230	140
130	159	240	120

VI TELEFILTER**SAW Filter Specification****TFS 400 C2****5/5**

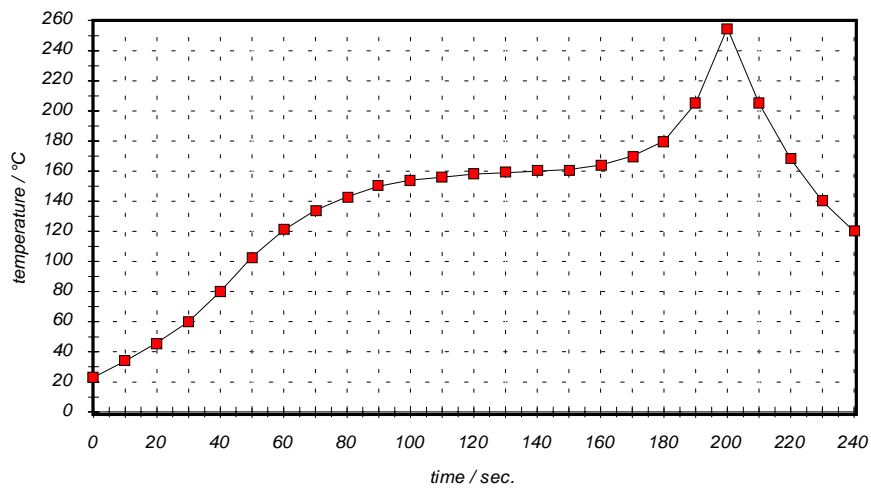
History

Version	Reason of Changes	Name	Date
1.0	Creation of specification as an compromise of customer requirements and given products	Dr. Wall	23.05.2000