

3.3-V, 12-BIT, 30 MSPS, LOW-POWER ANALOG-TO-DIGITAL CONVERTER WITH POWER DOWN

FEATURES

- 12-Bit Resolution, 30 MSPS Analog-to-Digital Converter
- Input Configurations:
 - Differential (0.5x)
 - Differential (1x)
- 3.3-V Supply Operation
- Internal Voltage Reference
- Out-of-Range Indicator
- Power-Down Mode
- IF Undersampling

APPLICATIONS

- Set Top Box (STB)
- Camcorders
- Digital Cameras
- Copiers
- Communications
- Test Instruments
- IF and Baseband Digitization

DW OR PW PACKAGE
(TOP VIEW)

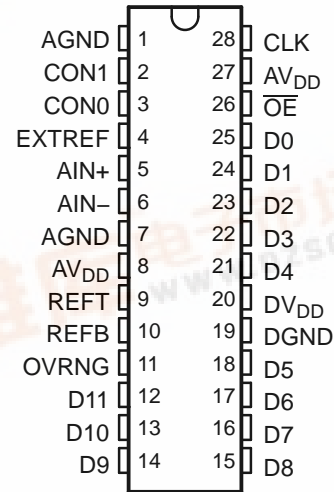

DESCRIPTION

The THS1230 is a CMOS, low-power, 12-bit, 30 MSPS analog-to-digital converter (ADC) that operates with a 3.3-V supply. The THS1230 gives circuit developers complete flexibility. The analog input to the THS1230 is differential with a gain of 0.5 for Mode 2 and 1.0 for Mode 1. The THS1230 provides a wide selection of voltage references to match the user's design requirements. For more design flexibility, the internal reference can be bypassed to use an external reference to suit the dc accuracy and temperature drift requirements of the application. The out-of-range output is used to monitor any out-of-range condition in the THS1230's input range.

The speed, resolution, and single-supply operation of the THS1230 are suited for applications in set top box (STB), video, multimedia, high-speed acquisition, and communications. The speed and resolution ideally suit charge-couple device (CCD) input systems such as digital copiers, digital cameras, and camcorders. The wide input voltage range between V_{REFB} and V_{REFT} allows the THS1230 to be designed into multiple systems.

The THS1230C is characterized for operation from 0°C to 70°C. The THS1230I is characterized for operation from -40°C to 85°C.

 This integrated circuit can be damaged by ESD. Texas Instruments recommends that all integrated circuits be handled with appropriate precautions. Failure to observe proper handling and installation procedures can cause damage.

ESD damage can range from subtle performance degradation to complete device failure. Precision integrated circuits may be more susceptible to damage because very small parametric changes could cause the device not to meet its published specifications.

ORDERING INFORMATION

PRODUCT	PACKAGE-LEAD	PACKAGE DESIGNATOR (1)	SPECIFIED TEMPERATURE RANGE	PACKAGE MARKING	ORDERING NUMBER	TRANSPORT MEDIA, QUANTITY
THS1230	TSSOP-28	PW	0°C to 70°C	TH1230	THS1230CPW	Tube, 50
THS1230	TSSOP-28	PW	0°C to 70°C	TH1230	THS1230CPWR	Tape and reel, 2000
THS1230	TSSOP-28	PW	-40°C to 85°C	TJ1230	THS1230IPW	Tube, 50
THS1230	TSSOP-28	PW	-40°C to 85°C	TJ1230	THS1230IPWR	Tape and reel, 2000
THS1230	SOP-28	DW	0°C to 70°C	TH1230	THS1230CDW	Tube, 20
THS1230	SOP-28	DW	0°C to 70°C	TH1230	THS1230CDWR	Tape and reel, 1000
THS1230	SOP-28	DW	-40°C to 85°C	TJ1230	THS1230IDW	Tube, 20
THS1230	SOP-28	DW	-40°C to 85°C	TJ1230	THS1230IDWR	Tape and reel, 1000

(1) For the most current specifications and package information refer to our Web site at www.ti.com.

FUNCTIONAL BLOCK DIAGRAM

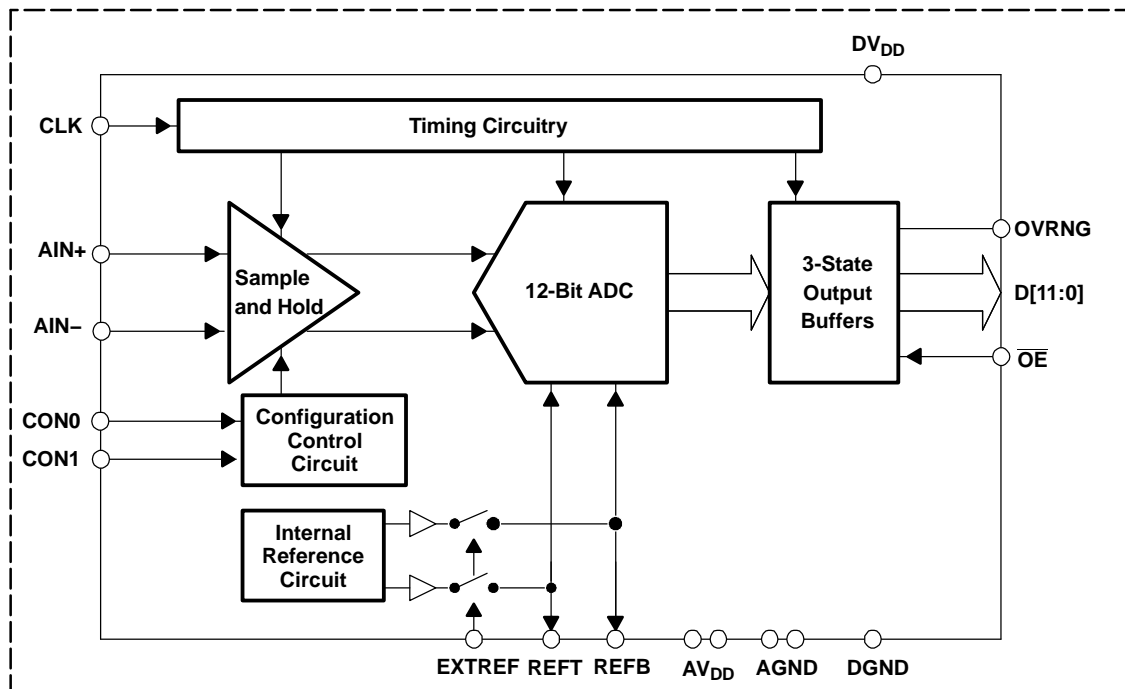

TERMINAL FUNCTIONS

TERMINAL		I/O	DESCRIPTION
NAME	NO.		
AGND	1, 7	I	Analog ground
AV _{DD}	8, 27	I	Analog supply
AIN+	5	I	Positive analog input
AIN-	6	I	Negative analog input
CLK	28	I	ADC conversion clock
CON1	2	I	Configuration input 1
CON0	3	I	Configuration input 0
DGND	19	I	Digital ground
DV _{DD}	20	I	Digital supply
D11	12	O	ADC data bit 11
D10	13	O	ADC data bit 10
D9	14	O	ADC data bit 9
D8	15	O	ADC data bit 8
D7	16	O	ADC data bit 7
D6	17	O	ADC data bit 6
D5	18	O	ADC data bit 5
D4	21	O	ADC data bit 4
D3	22	O	ADC data bit 3
D2	23	O	ADC data bit 2
D1	24	O	ADC data bit 1
D0	25	O	ADC data bit 0
EXTREF	4	I	Reference select input (high = external, low = internal)
OVRNG	11	O	Out of range indicator (high = out of range)
\overline{OE}	26	I	Output enable (high = disable, low = enable)
REFT	9	I/O	Upper ADC reference voltage
REFB	10	I/O	Lower ADC reference voltage

ABSOLUTE MAXIMUM RATINGS⁽¹⁾

over operating free-air temperature range (unless otherwise noted)

		UNIT
Supply voltage range	AV _{DD} to AGND, DV _{DD} to DGND	–0.3 V to 4 V
	AGND to DGND	–0.3 V to 0.3 V
Reference voltage input range, REFT, REFB to AGND		–0.3 to AV _{DD} + 0.3 V
Analog input voltage range, AIN+, AIN- to AGND		–0.3 to AV _{DD} + 0.3 V
Clock input voltage range, CLK to AGND		–0.3 to AV _{DD} + 0.3 V
Digital input voltage range, digital input to DGND		–0.3 to DV _{DD} + 0.3 V
Digital output voltage range, digital output to DGND		–0.3 to DV _{DD} + 0.3 V
Operating junction temperature range, T _J		–40°C to 150°C
Storage temperature range, T _{STG}		–65°C to 150°C
Lead temperature 1,6 mm (1/16 in) from case for 10 seconds		300°C

- (1) Stresses beyond those listed under "absolute maximum ratings" may cause permanent damage to the device. These are stress ratings only, and functional operation of the device at these or any other conditions beyond those indicated under "recommended operating conditions" is not implied. Exposure to absolute-maximum-rated conditions for extended periods may affect device reliability.

RECOMMENDED OPERATING CONDITIONSover operating free-air temperature range, T_A (unless otherwise noted)

		MIN	NOM	MAX	UNIT
POWER SUPPLY					
Supply voltage	V_{DD} DV_{DD}	3.0	3.3	3.6	V
ANALOG AND REFERENCE INPUTS					
Reference input voltage	V_{REFT}	$f_{CLK} = 5 \text{ MHz to } 30 \text{ MHz}$			V
	V_{REFB}	$f_{CLK} = 5 \text{ MHz to } 30 \text{ MHz}$			
Reference voltage differential, $V_{REFT} - V_{REFB}$		$f_{CLK} = 5 \text{ MHz to } 30 \text{ MHz}$			V
Analog input voltage differential, $(AIN+) - (AIN-)^{(1)}$	$CON1 = 0, CON0 = 1$		-1.0		1.0
	$CON1 = 1, CON0 = 0$		-2.0		2.0
Analog input capacitance, C_i					10
Clock input ⁽²⁾					AV_{DD}
DIGITAL OUTPUTS					
Minimum digital output load resistance, R_L					100
Maximum digital output load capacitance, C_i					0 10 15
DIGITAL INPUTS					
High-level input voltage, V_{IH}					DV_{DD}
Low-level input voltage, V_{IL}					DGND 0.8
Clock frequency, $f_{CLK}^{(3)}$					5 30
Clock pulse duration, $t_{w(CLKL)}, t_{w(CLKH)}$		$f_{CLK} = 30 \text{ MHz}$			15 16.7 18.3
Operating free-air temperature, T_A		TH1230			0 70
		TJ1230			-40 85

- (1) Based on $V_{REFT} - V_{REFB} = 1.0 \text{ V}$, varies proportional to the $V_{REFT} - V_{REFB}$ value. $AIN+$ and $AIN-$ inputs must always be greater than 0 V and less than AV_{DD} .
- (2) Clock pin is referenced to AGND and powered by AV_{DD} .
- (3) Clock frequency can be extended to this range without degradation of performance.

ELECTRICAL CHARACTERISTICS

 over recommended operating conditions ($AV_{DD} = DV_{DD} = 3.3\text{ V}$, $f_s = 30\text{ MHz}$ /50% duty cycle, MODE = 1, 1-V input span, internal reference, T_{min} to T_{max}) (unless otherwise noted)

DIGITAL INPUTS AND OUTPUTS (ALL SUPPLIES = 3.3 V)						
PARAMETER		TEST CONDITION	MIN	TYP	MAX	UNIT
DIGITAL INPUTS						
V_{IH}	High level input voltage	All other inputs	$0.8 \times DV_{DD}$			V
		CLK	$0.8 \times AV_{DD}$			
V_{IL}	Low level input voltage	All other inputs	$0.2 \times DV_{DD}$			V
		CLK	$0.2 \times AV_{DD}$			
I_{IH}	High level input current				1	μA
I_{IL}	Low level input current				-1	μA
C_i	Input capacitance			5		pF
DIGITAL OUTPUTS						
V_{OH}	High level output voltage	$I_{load} = 50\ \mu\text{A}$	$DV_{DD}-0.4$			V
V_{OL}	Low level output voltage	$I_{load} = -50\ \mu\text{A}$	0.4			
	High impedance output current				± 1	μA
t_r/t_f	Rise/fall time	$C_L = 10\ \text{pF}$		4.5		ns
ANALOG INPUTS						
C_i	Switched input capacitance			6		pF
$t_{d(ap)}$	Aperture delay time			2		ns
	Aperture uncertainty (jitter)			2		ps
	DC leakage current (input = $\pm\text{FS}$)			10		μA
POWER SUPPLY (CLK = 30 MHz)						
XV_{DD}	Supply voltage (all supplies)		3	3.3	3.6	V
I_{DD}	Supply current active - total			48	66	mA
$I_{(analog)}$	Supply current active - analog			35		
$I_{(digital)}$	Supply current active - digital			13		
$I_{I(standby)}$	Standby supply current	CLK = 0 MHz			10	μA
$t_{(PU)}$	Power-up time for references from standby	1 μF Bypass ⁽¹⁾		770		μs
		10 μF Bypass ⁽¹⁾		6.2		ms
$t_{(PUconv)}$	Power-up time for valid ADC conversions	See Note ⁽²⁾		720		ns
P_D	Power dissipation	See Note ⁽³⁾		168	220	mW
		See Note ⁽⁴⁾		188		
$P_{D(STBY)}$	Standby power dissipation	CLK = 0 MHz			36	μW
PSRR	Power supply rejection ratio			± 0.1		%FS

- (1) Time for reference to recover to 1% of its final voltage level.
 (2) Time for ADC conversions to be accurate to within 0.1% of fullscale, INT cks.
 (3) Clock = 30 MHz, AIN+ and AIN- at Common Mode or 1.65 V DC.
 (4) Clock = 30 MHz, $f_{in} = 3.58\text{ MHz}$ at -1 dBFS.

ELECTRICAL CHARACTERISTICS (CONTINUED)

over recommended operating conditions ($AV_{DD} = DV_{DD} = 3.3\text{ V}$, $f_s = 30\text{ MHz}/50\%$ duty cycle, $\text{MODE} = 1$, 1-V input span, internal reference, T_{\min} to T_{\max}) (unless otherwise noted)

REFT, REFB REFERENCE VOLTAGES (all supplies = 3.3 V)						
PARAMETER		TEST CONDITION	MIN	TYP	MAX	UNIT
INTERNAL REFERENCE⁽¹⁾						
V_{REFT}	Upper reference voltage			2.15		V
V_{REFB}	Lower reference voltage			1.15		
V_{REF}	Differential reference voltage, $V_{\text{REFT}} - V_{\text{REFB}}$		0.95	1	1.05	
	Differential reference voltage, $V_{\text{REFT}} - V_{\text{REFB}}$ accuracy		-5%		5%	
EXTERNAL REFERENCE						
	Externally applied V_{REFT} reference voltage range		2		2.5	V
	Externally applied V_{REFB} reference voltage range		1.05		1.3	
	Externally applied ($V_{\text{REFT}} - V_{\text{REFB}}$) reference voltage range		0.75		1.05	
	External mode V_{REFT} to V_{REFB} impedance			9		k Ω
INTERNAL OR EXTERNAL REFERENCE						
C_T	V_{REFT} decoupling capacitor value			0.1		μF
C_B	V_{REFB} decoupling capacitor value			0.1		
C_{TB}	Decoupling capacitor V_{REFT} to V_{REFB}			10		

(1) The internal reference voltage is not intended for use driving off chip.

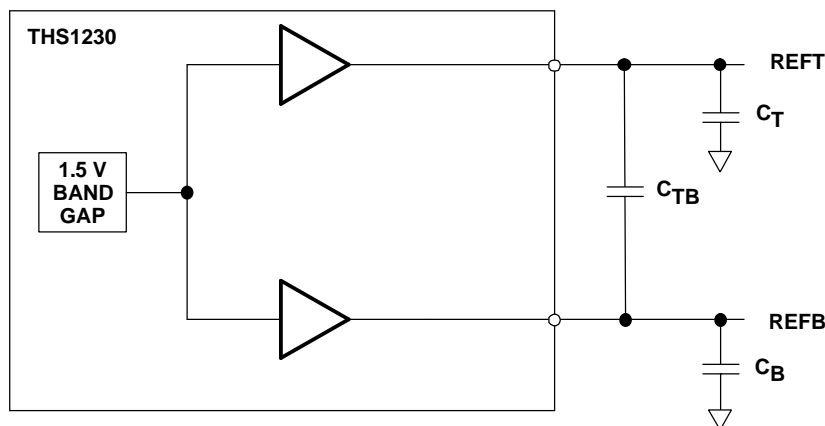

Figure 1. Reference Generation

ELECTRICAL CHARACTERISTICS (CONTINUED)

 over recommended operating conditions ($AV_{DD} = DV_{DD} = 3.3\text{ V}$, $f_s = 30\text{ MHz}/50\%$ duty cycle, $\text{MODE} = 1$, 1-V input span, internal reference, T_{\min} to T_{\max}) (unless otherwise noted)

PARAMETER		TEST CONDITIONS	MIN	TYP	MAX	UNIT
DC ACCURACY (LINEARITY)						
	Number of missing codes	All modes			0	codes
DNL	Differential nonlinearity	All modes		± 0.4	± 1	LSB
INL	Integral nonlinearity	All modes	-2.5	± 1.2	2	LSB
	Offset error	All modes		0.7	1.2	%FSR
	Gain error	All modes		1.1	3.5	%FSR
DYNAMIC PERFORMANCE⁽¹⁾						
ENOB	Effective number of bits	$f_i = 3.58\text{ MHz}$		10.9		Bits
		$f_i = 10\text{ MHz}$	10.4	10.6		
		$f_i = 15\text{ MHz}$		10.4		
THD	Total harmonic distortion	$f_i = 3.58\text{ MHz}$		-76		dB
		$f_i = 10\text{ MHz}$		-74	-65	
		$f_i = 15\text{ MHz}$		-72.5		
SNR	Signal-to-noise ratio	$f_i = 3.58\text{ MHz}$		68		dB
		$f_i = 10\text{ MHz}$	64.5	65.6		
		$f_i = 15\text{ MHz}$		64.6		
SINAD	Signal-to-noise + distortion	$f_i = 3.58\text{ MHz}$		67.4		dB
		$f_i = 10\text{ MHz}$	64	65		
		$f_i = 15\text{ MHz}$		64.5		
SFDR	Spurious free dynamic range	$f_i = 3.58\text{ MHz}$		78.1		dB
		$f_i = 10\text{ MHz}$	67	74		
		$f_i = 15\text{ MHz}$		72		
	Analog input bandwidth			180		MHz
	Differential phase, DP			0.12		degree
$G_{(\text{diff})}$	Differential gain			0.01%		
TIMING (all supplies = 3.3 V)						
f_{CLK}	Clock frequency ⁽²⁾		5		30	MHz
	Clock duty cycle		45%	50%	55%	
$t_{d(O)}$	Output delay time			7	19	ns
$t_{d(PZ)}$	Delay time, output disable to Hi-Z output			3.2		ns
$t_{d(EN)}$	Delay time, output enable to output valid			5	19	ns
	Latency				5	cycles

(1) Input amplitudes for all single tone dynamic tests are at -1 dBFS, all supplies = 3.3 V.

(2) The clock frequency may be extended to 5 MHz without degradation in specified performance.

PARAMETER MEASUREMENT INFORMATION

TIMING DIAGRAM

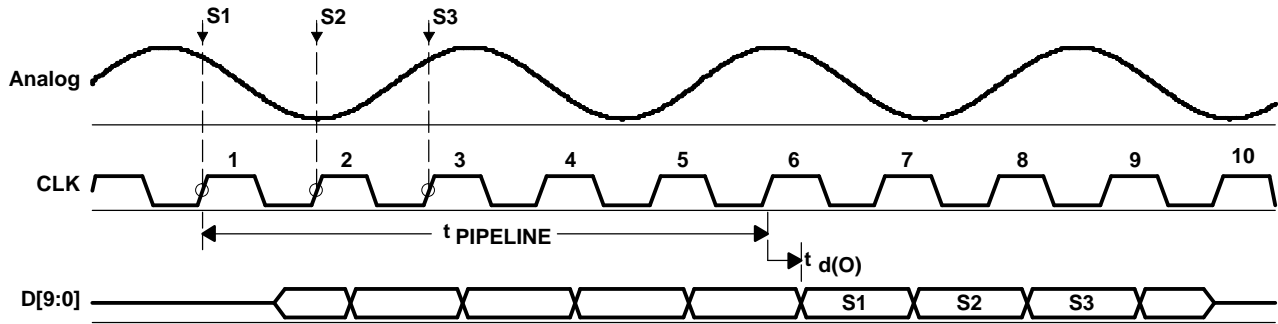

Figure 2. Analog Input and Data Output Timing

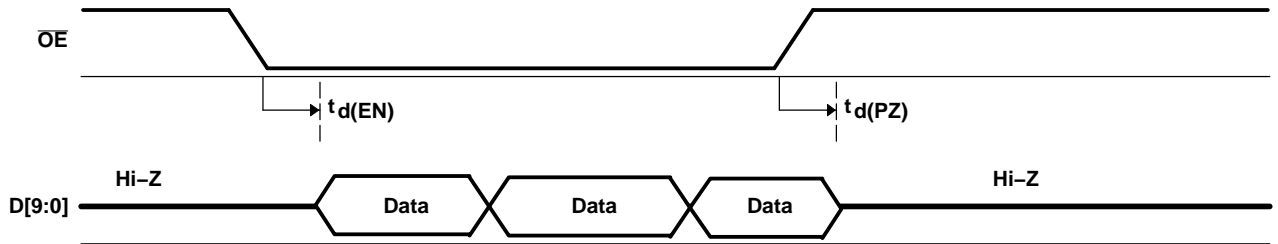

Figure 3. Output Enable Timing

TYPICAL CHARACTERISTICS

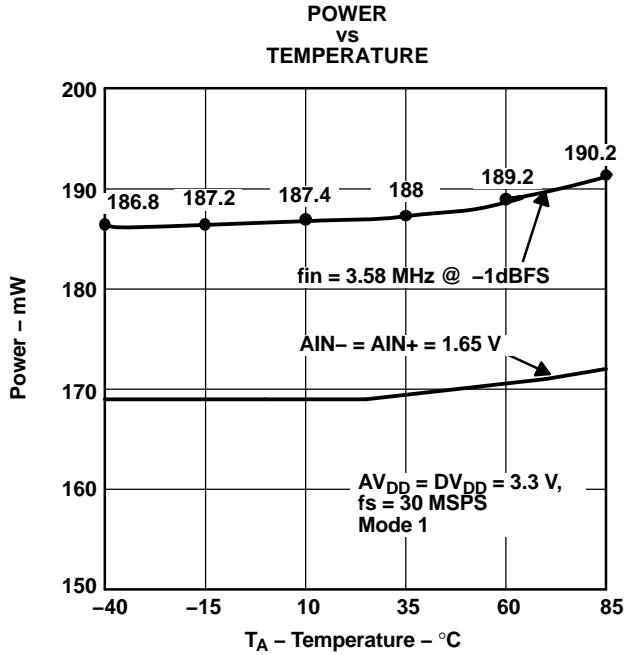

Figure 4.

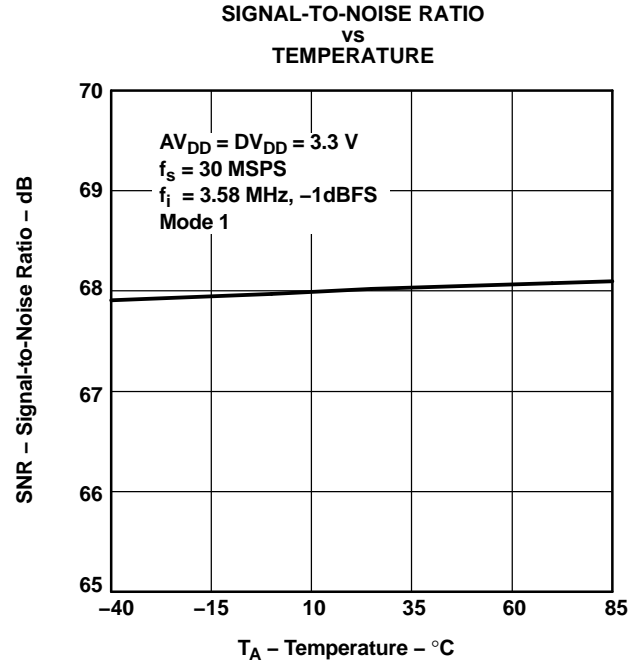

Figure 5.

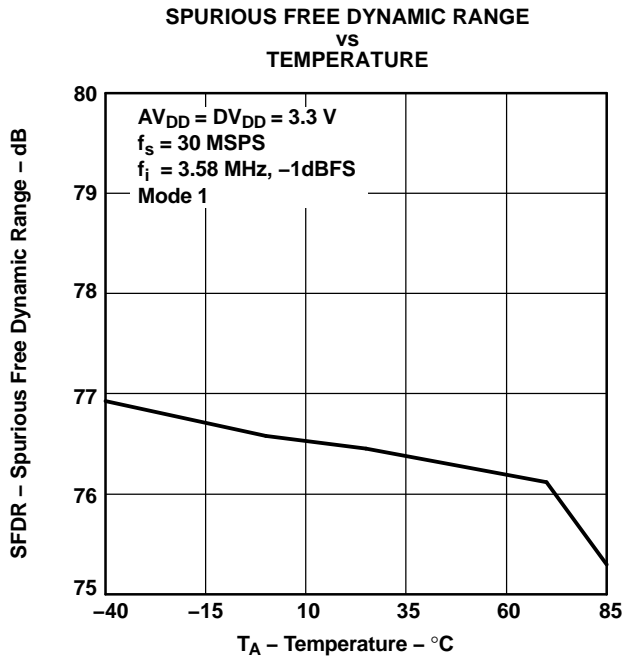

Figure 6.

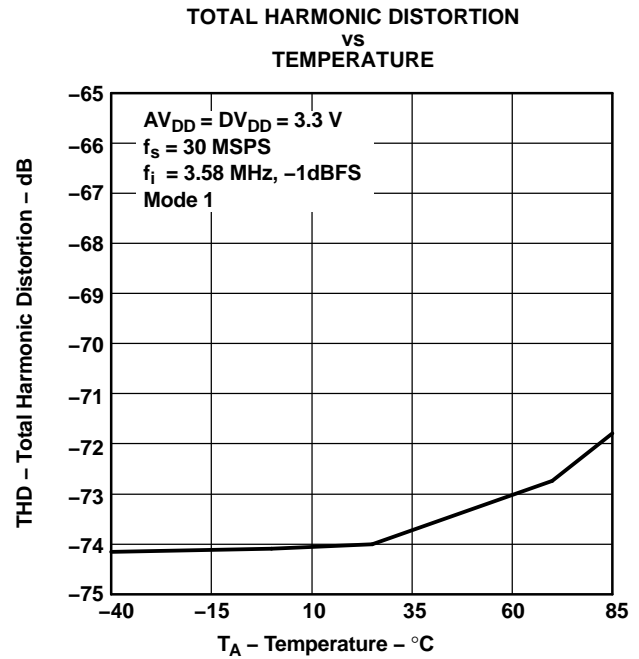

Figure 7.

TYPICAL CHARACTERISTICS (continued)

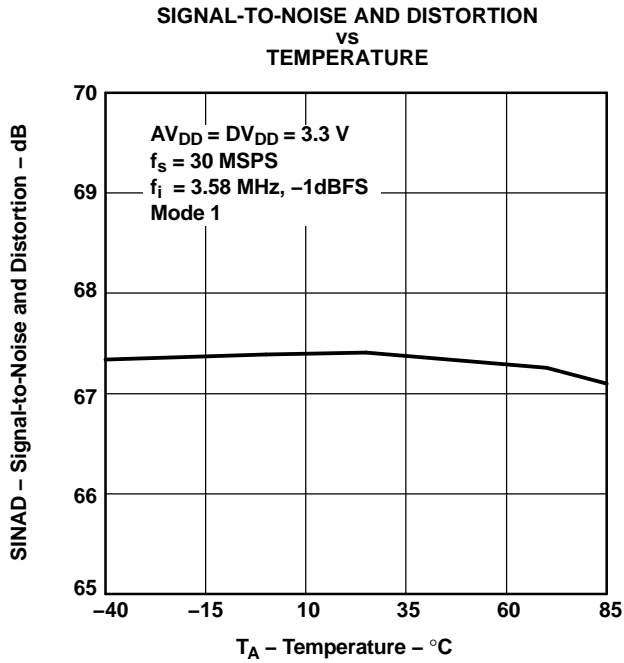

Figure 8.

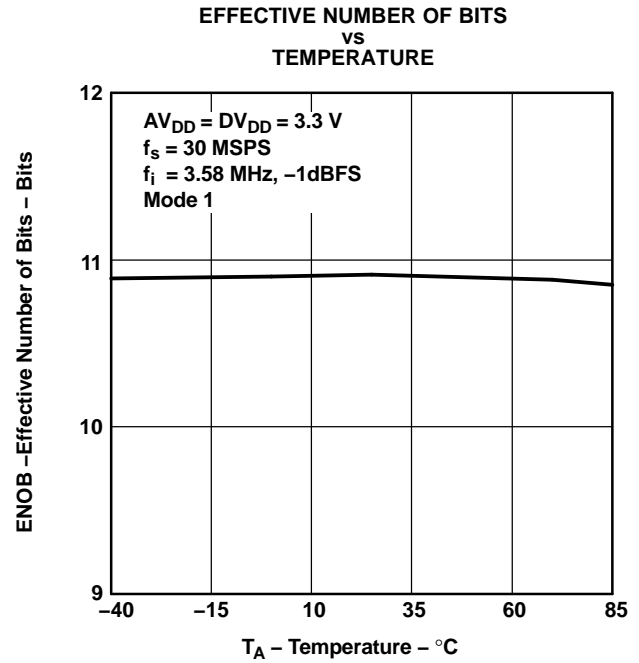

Figure 9.

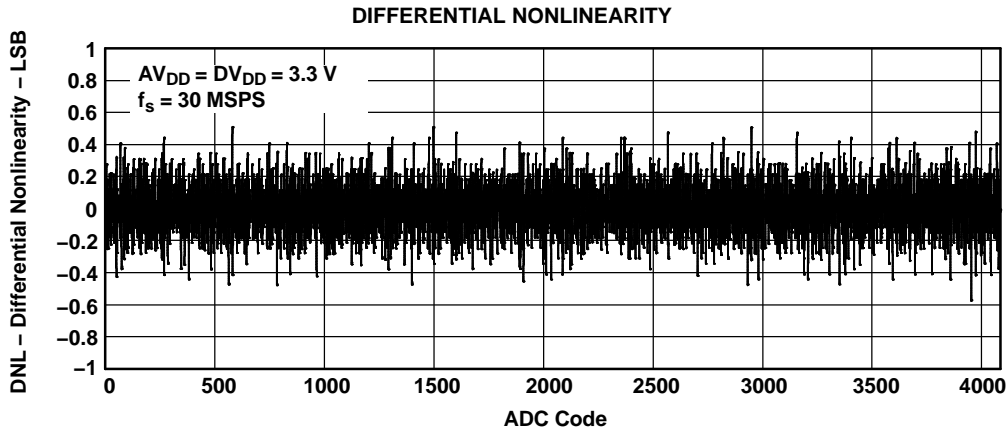

Figure 10.

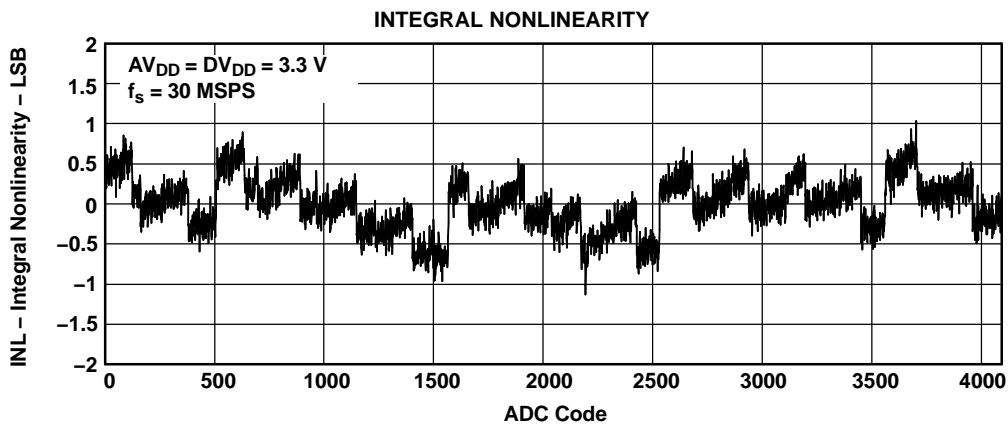

Figure 11.

TYPICAL CHARACTERISTICS (continued)

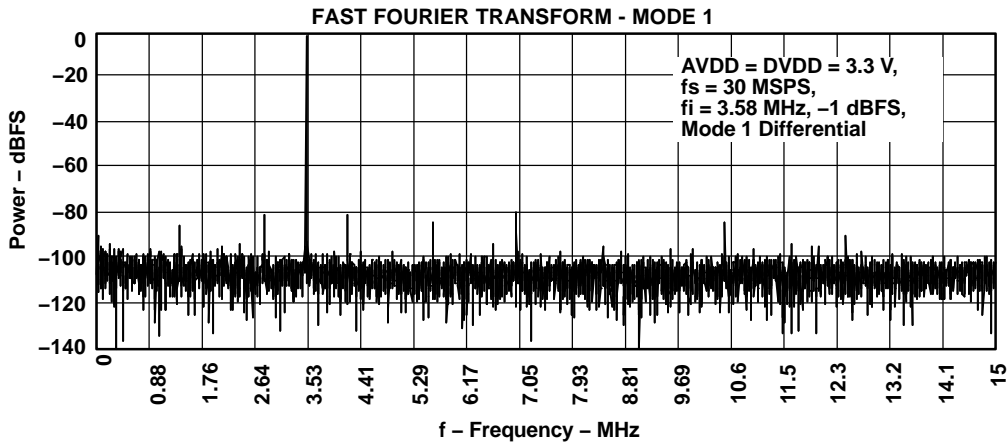

Figure 12.

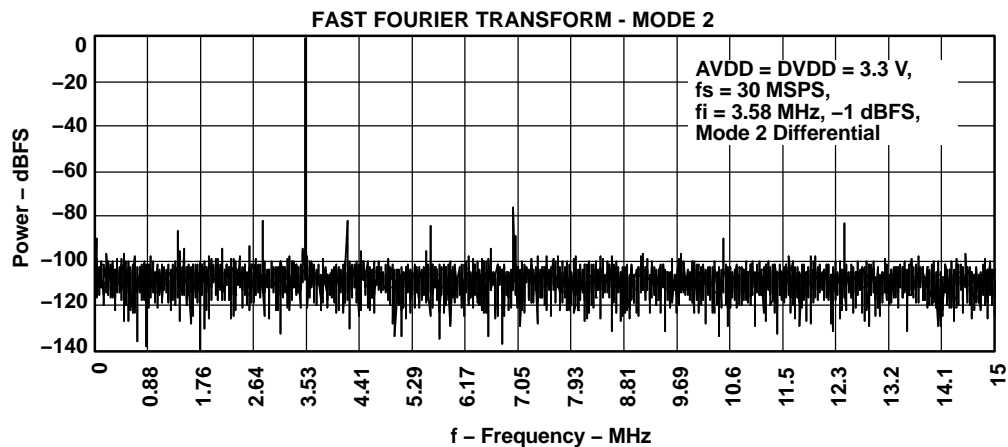

Figure 13.

PRINCIPLES OF OPERATION

Analog Input

The analog input AIN is sampled in the sample and hold unit, the output of which feeds the ADC CORE, where the process of analog to digital conversion is performed against ADC reference voltages, V_{REFT} and V_{REFB} .

Connecting the EXTREF pin to one of two voltages, DGND or DV_{DD} selects one of the two configurations of ADC reference generation. The ADC reference voltages come from either the internal reference buffer or completely external sources. Connect EXTREF to DGND for internal reference generation or to DV_{DD} for external reference generation.

CON0 and CON1 as described below, select the input configuration mode or place the device in powerdown. The ADC core drives out through output buffers to the data pins D0 to D11. The output buffers can be disabled by the \overline{OE} pin.

A single, sample-rate clock (30 MHz maximum) is required at pin CLK. The analog input signal is sampled on the rising edge of CLK, and corresponding data is output after the fifth following rising edge.

The THS1230 can operate in differential Mode 1 or differential Mode 2, controlled by the configuration pins CON0 and CON1 as shown in Table 1. Mode 0 places the device in power-down state or standby for reduced power consumption.

Table 1. Input Modes of Operation

MODE	CON1	CON0	MODE OF OPERATION
0	0	0	Device powered down
1	0	1	Differential mode × 1
2	1	0	Differential mode × 0.5
3	1	1	Not used

Modes 1 and 2 are shown in Figure 14.

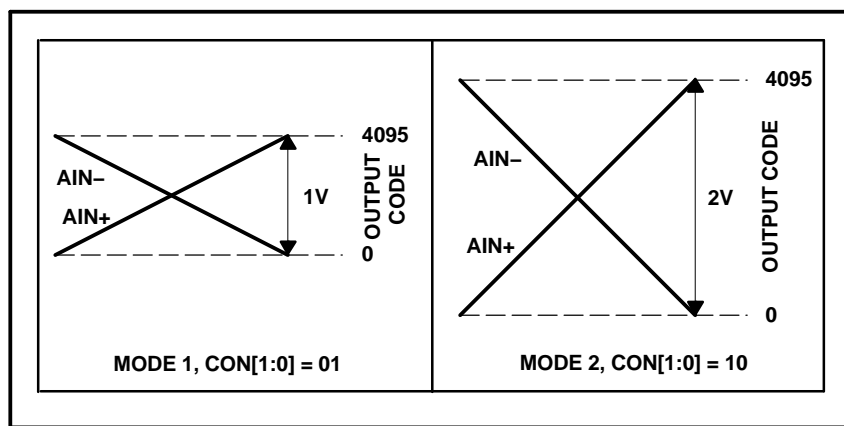

Figure 14. Input Mode Configurations

The gain of the sample and hold changes with the CON1 and the CON0 inputs. Table 2 shows the gain of the sample and hold and the levels applied at the AIN+ and AIN– analog inputs for Mode 1 and Mode 2. The common mode level for the two analog inputs is at AVDD/2.

Table 2. Input Mode Switching

MODE	CON1	CON0	(AIN+) – (AIN–) MIN	(AIN+) – (AIN–) MAX	S/H GAIN
1	0	1	–1 V	1 V	×1
2	1	0	–2 V	2 V	×0.5

Table 2 assumes that the delta in ADC reference voltages V_{REFT} and V_{REFB} is set to 1 V, i.e., $V_{REFT} - V_{REFB} = 1$ V. Note that V_{REFB} and V_{REFT} can be set externally, which will scale the numbers given in this table.

The user-chosen operating configuration and reference voltages determine what input signal voltage range the THS1230 can handle.

The following sections explain both the internal signal flow of the device and how the input signal span is related to the ADC reference voltages, as well as the ways in which the ADC reference voltages can be buffered internally or externally applied.

Signal Processing Chain (Sample and Hold, ADC)

Figure 15 shows the signal flow through the sample and hold unit and the PGA to the ADC core.

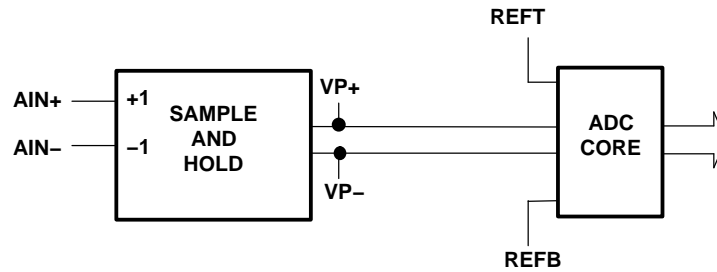

Figure 15. Analog Input Signal Flow

Sample and Hold

The differential sample and hold processes A_{IN} with respect to the voltages applied to the REFT and REFB pins, to give a differential output $(VP+) - (VP-) = VP$ given by:

- $VP = (AIN+) - (AIN-)$

Analog-to-Digital Converter

No matter what operating configuration is chosen, VP is digitized against ADC reference voltages V_{REFT} and V_{REFB} . The V_{REFT} and V_{REFB} voltages set the analog input span limits $FS+$ and $FS-$, respectively. Any voltages at A_{IN} greater than REFT or less than REFB causes ADC over-range, which is signaled by OVR going high when the conversion result is output.

Analog Input

A first-order approximation for the equivalent analog input circuit of the THS1230 is shown in Figure 16. The equivalent input capacitance C_1 is 5 pF typical. The input must charge/discharge this capacitance within the sample period of one half of a clock cycle. When a full-scale voltage step is applied, the input source provides the charging current through the switch resistance R_{SW} (200 Ω) of S1 and quickly settles. In this case the input impedance is low. Alternatively, when the source voltage equals the value previously stored on C_1 , the hold capacitor requires no input current and the equivalent input impedance is very high.

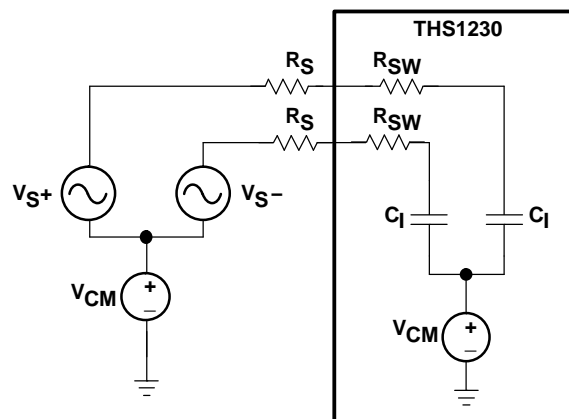

Figure 16. Simplified Equivalent Input Circuit

To maintain the frequency performance outlined in the specifications, the total source impedance should be limited to the following equation with $f_{CLK} = 30$ MHz, $C_1 = 5$ pF, $R_{SW} = 200$ Ω :

$$R_S < \frac{1}{2f_{CLK} \times C_1 \times \ln(256)} R_{SW}$$

So, for applications running at a lower f_{CLK} , the total source resistance can increase proportionally.

The analog input of the THS1230 is a differential input that can be configured in various ways depending on the signal source and the required level of performance. A fully differential connection (see Figure 17) delivers the best performance from the converter.

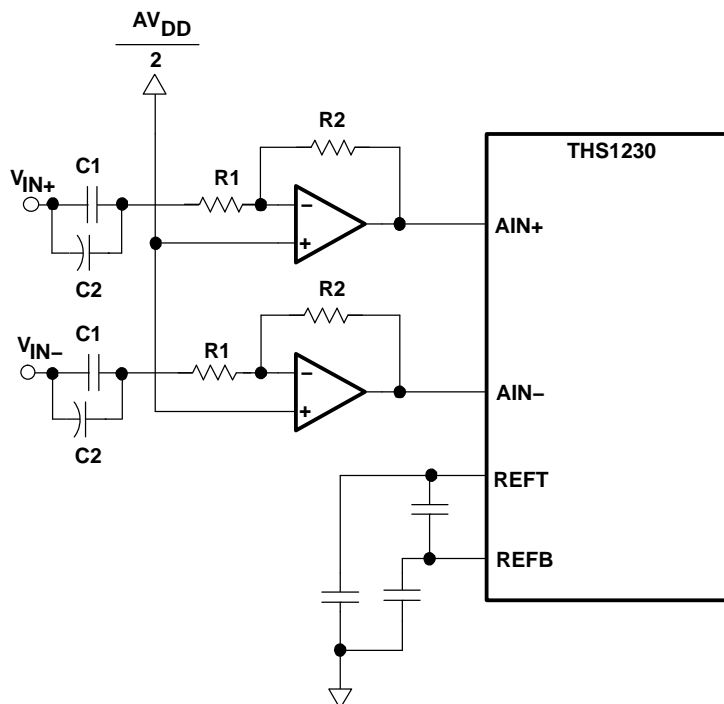

Figure 17. AC-Coupled Differential Input

The analog input can be dc-coupled (see Figure 18) as long as the inputs are within the analog input common mode voltage range. For example (see Figure 18), $V+$ and $V-$ are signals centered on GND with a peak-to-peak voltage of 2 V, and the circuit in Figure 18 is used to interface it with the THS1230. Assume AV_{DD} of the converter is 3 V. Two problems have to be solved. The first is to shift common mode level (CML) from 0 V to 1.5 V ($AV_{DD}/2$). To do that, a V bias voltage and an adequate ratio of R1 and R2 have to be selected. For instance, if $V_{bias} = AV_{DD} = 3$ V, then $R1 = R2$. The second is that the differential voltage has to be reduced from 4 V (2×2 V) to 1 V, and for that an attenuation of 4 to1 is needed. The attenuation is determined by the relation: $(R3 || 2R2) / ((R3 || 2R2) + 2R1)$. One possible solution is $R1 = R2 = R3 = 150 \Omega$. In this case, moreover, the input impedance ($2R1 + (R3 || 2R2)$) will be 400 Ω . The values can be changed to match any other input impedance. A capacitor, C, connected from AIN+ to AIN- helps filter any high frequency noise on the inputs, also improving performance. Note that the chosen value of capacitor C must take into account the highest frequency component of the analog input signal.

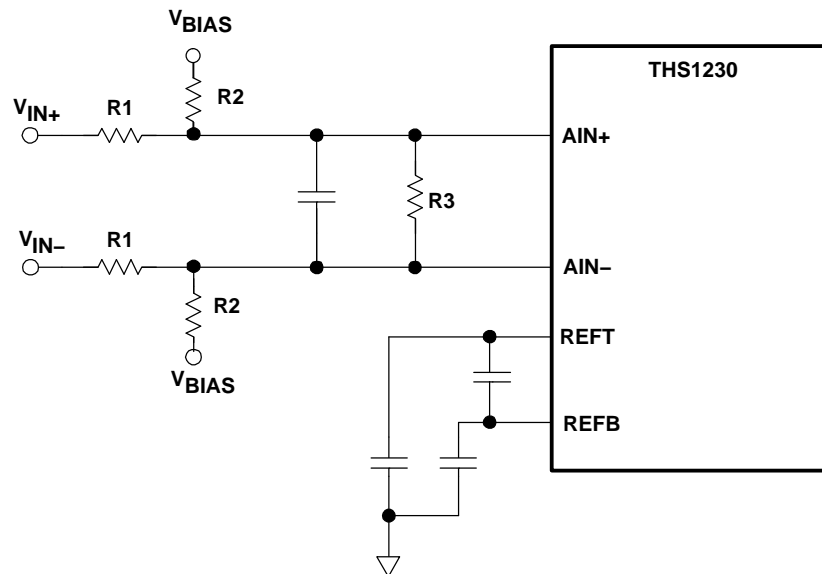

Figure 18. DC-Coupled Differential Input Circuit

A single-ended source may give better overall system performance when it is converted to a differential signal before driving the THS1230. The configuration in Figure 19 takes a V_{IN} of 1 V and drives the 1:1 transformer ratio so that value of A_{IN+} and A_{IN-} converts to fullscale value at the ADC digital output. With V_{IN} at -1 V the value at A_{IN+} and A_{IN-} converts to 0 at the ADC digital outputs.

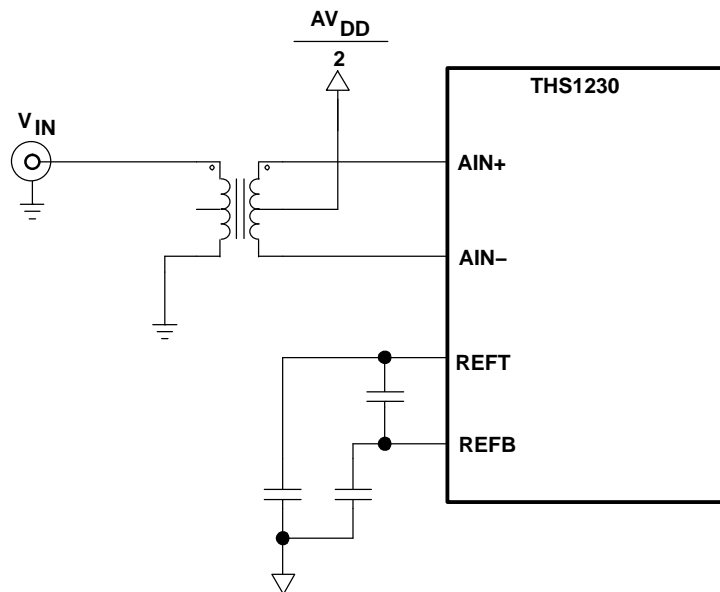

Figure 19. Transformer Coupled Single-Ended Input

Digital Outputs

The output of THS1230 is in unsigned binary code. The ADC input over-range indicator is output on pin OVRNG. Capacitive loading on the output should be kept as low as possible (a maximum loading of 10 pF is recommended) to ensure best performance. Higher output loading causes higher dynamic output currents and can therefore increase noise coupling into the part's analog front end. To drive higher loads the use of an output buffer is recommended.

When clocking output data from THS1230, it is important to observe its timing relation to CLK. The pipeline ADC delay is 5 clock cycles to which the maximum output propagation delay needs to be added.

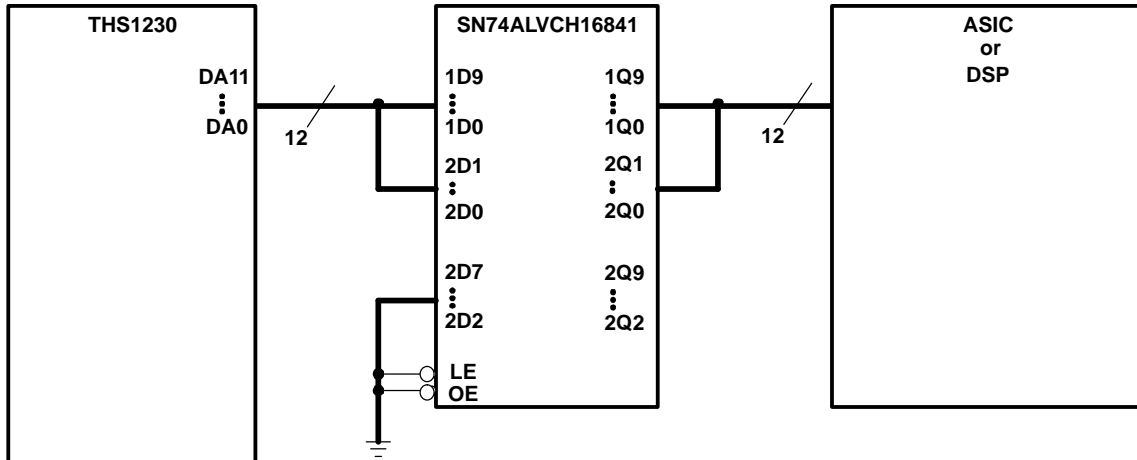

Figure 20. Buffered Output Connection

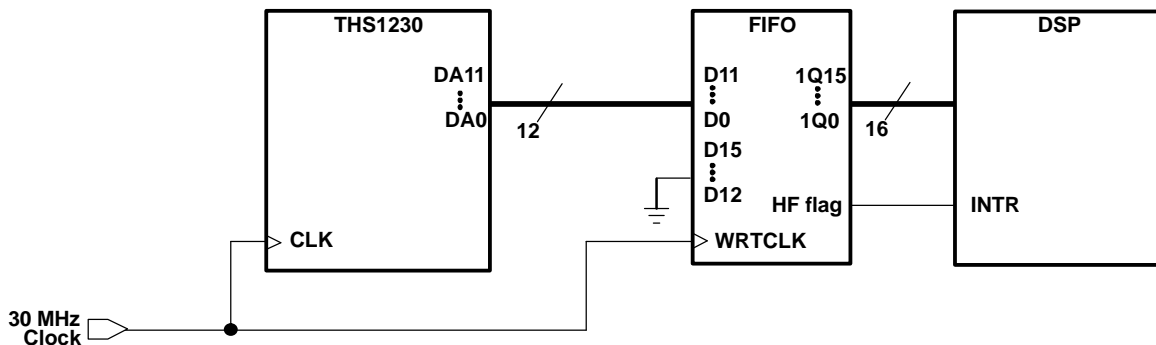

Figure 21. FIFO Connection

Layout, Decoupling and Grounding Rules

Proper grounding and layout of the PCB on which THS1230 is populated is essential to achieve the stated performance. It is advised to use separate analog and digital ground planes that are spliced underneath the IC. THS1230 has digital and analog pins on opposite sides of the package to make this easier. Because there is no connection internally between analog and digital grounds, they have to be joined on the PCB. It is advised to do this at one point in close proximity to THS1230.

Because of the high sampling rate and switched-capacitor architecture, THS1230 generates transients on the supply and reference lines. Proper decoupling of these lines is therefore essential. Decoupling is recommended as shown in the schematic of the THS1230 evaluation module in Figure 22.

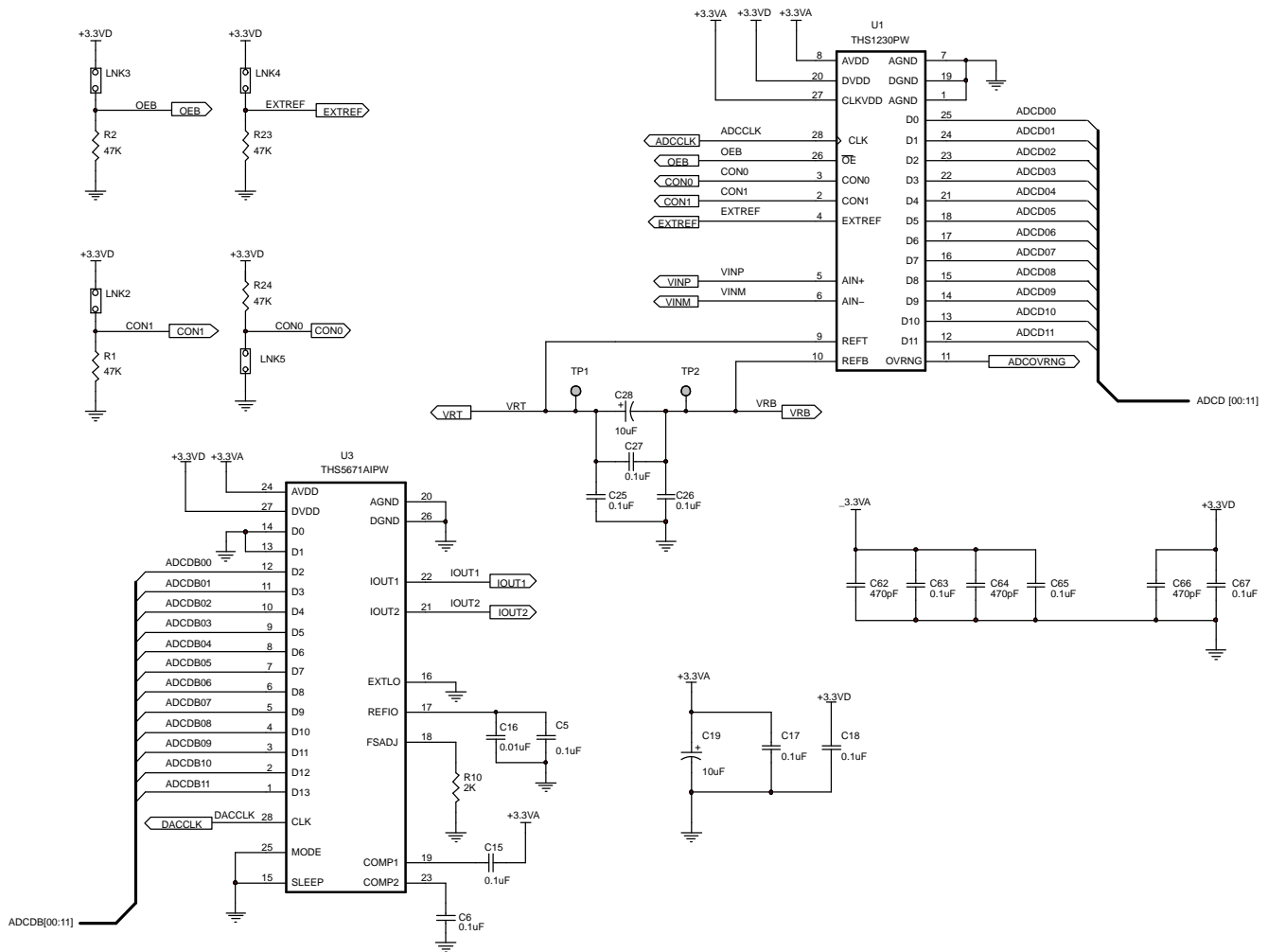

Figure 22. EVM Schematic

DEFINITIONS OF SPECIFICATIONS AND TERMINOLOGY

Integral Nonlinearity (INL)

Integral nonlinearity refers to the deviation of each individual code from a line drawn from zero through full scale. The point used as zero occurs 1/2 LSB before the first code transition. The full-scale point is defined as level 1/2 LSB beyond the last code transition. The deviation is measured from the center of each particular code to the true straight line between these two end-points.

Differential Nonlinearity (DNL)

An ideal ADC exhibits code transitions that are exactly 1 LSB apart. DNL is the deviation from this ideal value. Therefore, this measure indicates how uniform the transfer function step sizes are. The ideal step size is defined here as the step size for the device under test, i.e. (last transition level - first transition level)/(2n - 2). Using this definition for DNL separates the effects of gain and offset error. A minimum DNL better than -1 LSB ensures no missing codes.

Offset and Gain Error

Offset error (in LSBs) is defined as the average offset for all inputs, and gain error is defined as the maximum error (in LSBs) caused by the angular deviation from the offset corrected straight line.

Analog Input Bandwidth

The analog input bandwidth is defined as the maximum frequency of a 1-dBFS input sine wave that can be applied to the device for which an extra 3-dB attenuation is observed in the reconstructed output signal.

Output Timing

Output timing $t_{d(O)}$ is measured from the 50% level of the CLK input falling edge to the 10%/90% level of the digital output. The digital output load is not higher than 10 pF.

Output hold time $t_{h(O)}$ is measured from the 50% level of the CLK input falling edge to the 10%/90% level of the digital output. The digital output load is not less than 2 pF.

Aperture delay $t_{d(A)}$ is measured from the 50% level of the CLK input to the actual sampling instant.

The OE signal is asynchronous.

OE timing $t_{d(PZ)}$ is measured from the $V_{IH(min)}$ level of OE to the high-impedance state of the output data. The digital output load is not higher than 10 pF.

OE timing $t_{d(EN)}$ is measured from the $V_{IL(max)}$ level of OE to the instant when the output data reaches $V_{OH(min)}$ or $V_{OL(max)}$ output levels. The digital output load is not higher than 10 pF.

Signal-to-Noise Ratio + Distortion (SINAD)

SINAD is the ratio of the rms value of the measured input signal to the rms sum of all other spectral components below the Nyquist frequency, including harmonics but excluding dc. The value for SINAD is expressed in decibels.

Effective Number of Bits (ENOB)

For a sine wave, SINAD can be expressed in terms of the number of bits. Using the following formula,

- $N = (\text{SINAD} - 1.76)/6.02$

it is possible to get a measure of performance expressed as N, the effective number of bits. Thus, effective number of bits for a device for sine wave inputs at a given input frequency can be calculated directly from its measured SINAD.

Total Harmonic Distortion (THD)

THD is the ratio of the rms sum of the first six harmonic components to the rms value of the measured input signal and is expressed as a percentage or in decibels.

Spurious Free Dynamic Range (SFDR)

SFDR is the difference in dB between the rms amplitude of the input signal and the peak spurious signal.

PACKAGING INFORMATION

Orderable Device	Status ⁽¹⁾	Package Type	Package Drawing	Pins	Package Qty	Eco Plan ⁽²⁾	Lead/Ball Finish	MSL Peak Temp ⁽³⁾
THS1230CDW	ACTIVE	SOIC	DW	28	20	Pb-Free (RoHS)	CU NIPDAU	Level-2-250C-1YEAR/ Level-1-220C-UNLIM
THS1230CDWR	ACTIVE	SOIC	DW	28	1000	Pb-Free (RoHS)	CU NIPDAU	Level-2-250C-1YEAR/ Level-1-220C-UNLIM
THS1230CPW	ACTIVE	TSSOP	PW	28	50	None	CU NIPDAU	Level-2-220C-1 YEAR
THS1230CPWG4	ACTIVE	TSSOP	PW	28	50	Green (RoHS & no Sb/Br)	CU NIPDAU	Level-1-260C-UNLIM
THS1230CPWR	ACTIVE	TSSOP	PW	28	2000	None	CU NIPDAU	Level-2-220C-1 YEAR
THS1230IDW	ACTIVE	SOIC	DW	28	20	Pb-Free (RoHS)	CU NIPDAU	Level-2-250C-1YEAR/ Level-1-220C-UNLIM
THS1230IDWR	ACTIVE	SOIC	DW	28	1000	Pb-Free (RoHS)	CU NIPDAU	Level-2-250C-1YEAR/ Level-1-220C-UNLIM
THS1230IPW	ACTIVE	TSSOP	PW	28	50	None	CU NIPDAU	Level-2-220C-1 YEAR
THS1230IPWR	ACTIVE	TSSOP	PW	28	2000	None	CU NIPDAU	Level-2-220C-1 YEAR

⁽¹⁾ The marketing status values are defined as follows:

ACTIVE: Product device recommended for new designs.

LIFEBUY: TI has announced that the device will be discontinued, and a lifetime-buy period is in effect.

NRND: Not recommended for new designs. Device is in production to support existing customers, but TI does not recommend using this part in a new design.

PREVIEW: Device has been announced but is not in production. Samples may or may not be available.

OBSOLETE: TI has discontinued the production of the device.

⁽²⁾ Eco Plan - May not be currently available - please check <http://www.ti.com/productcontent> for the latest availability information and additional product content details.

None: Not yet available Lead (Pb-Free).

Pb-Free (RoHS): TI's terms "Lead-Free" or "Pb-Free" mean semiconductor products that are compatible with the current RoHS requirements for all 6 substances, including the requirement that lead not exceed 0.1% by weight in homogeneous materials. Where designed to be soldered at high temperatures, TI Pb-Free products are suitable for use in specified lead-free processes.

Green (RoHS & no Sb/Br): TI defines "Green" to mean "Pb-Free" and in addition, uses package materials that do not contain halogens, including bromine (Br) or antimony (Sb) above 0.1% of total product weight.

⁽³⁾ MSL, Peak Temp. -- The Moisture Sensitivity Level rating according to the JEDEC industry standard classifications, and peak solder temperature.

Important Information and Disclaimer: The information provided on this page represents TI's knowledge and belief as of the date that it is provided. TI bases its knowledge and belief on information provided by third parties, and makes no representation or warranty as to the accuracy of such information. Efforts are underway to better integrate information from third parties. TI has taken and continues to take reasonable steps to provide representative and accurate information but may not have conducted destructive testing or chemical analysis on incoming materials and chemicals. TI and TI suppliers consider certain information to be proprietary, and thus CAS numbers and other limited information may not be available for release.

In no event shall TI's liability arising out of such information exceed the total purchase price of the TI part(s) at issue in this document sold by TI to Customer on an annual basis.

MECHANICAL DATA

DW (R-PDSO-G28)

PLASTIC SMALL-OUTLINE PACKAGE

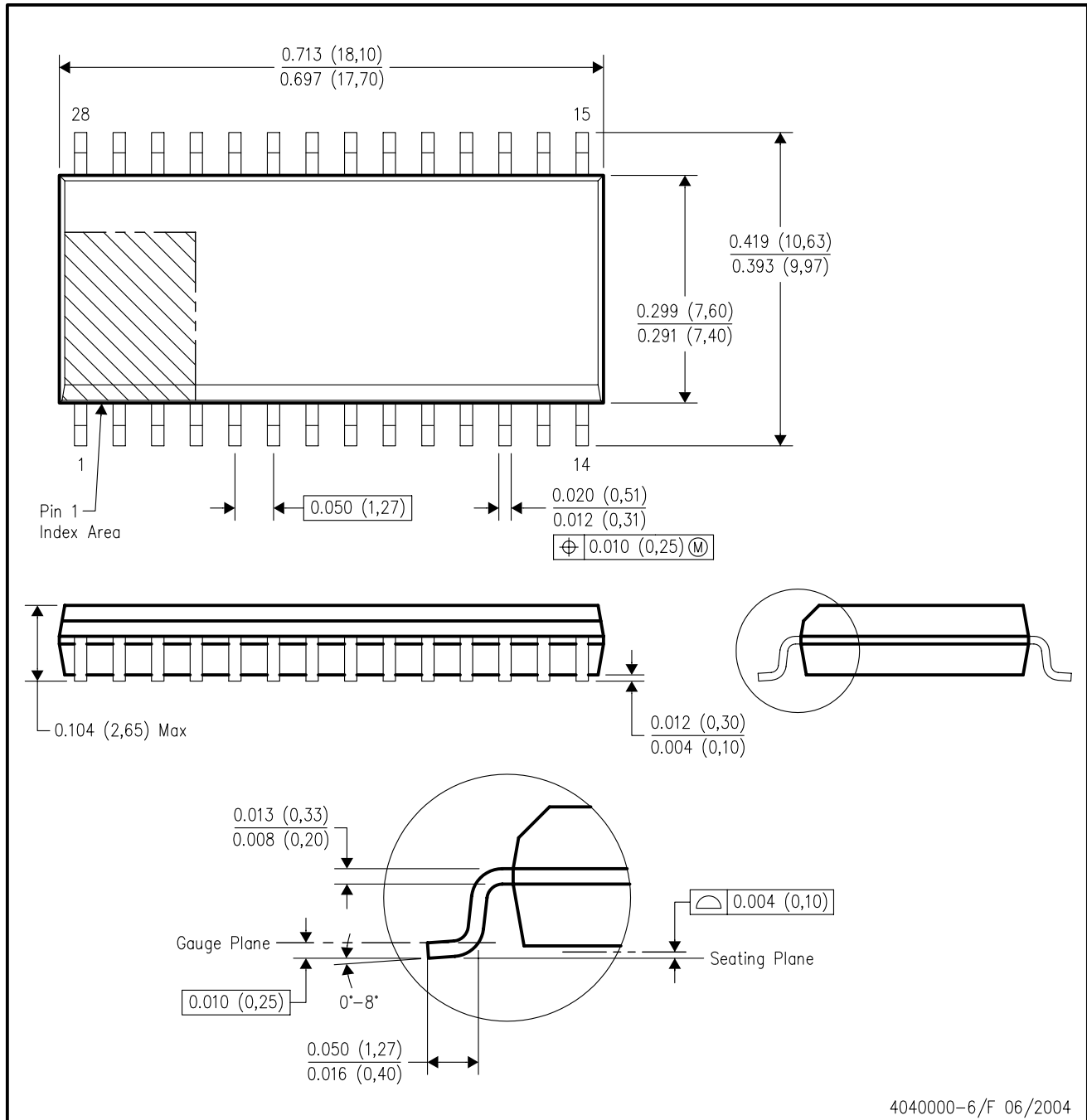

4040000-6/F 06/2004

- NOTES:
- All linear dimensions are in inches (millimeters).
 - This drawing is subject to change without notice.
 - Body dimensions do not include mold flash or protrusion not to exceed 0.006 (0,15).
 - Falls within JEDEC MS-013 variation AE.

MECHANICAL DATA

MTSS001C – JANUARY 1995 – REVISED FEBRUARY 1999

PW (R-PDSO-G)**

PLASTIC SMALL-OUTLINE PACKAGE

14 PINS SHOWN

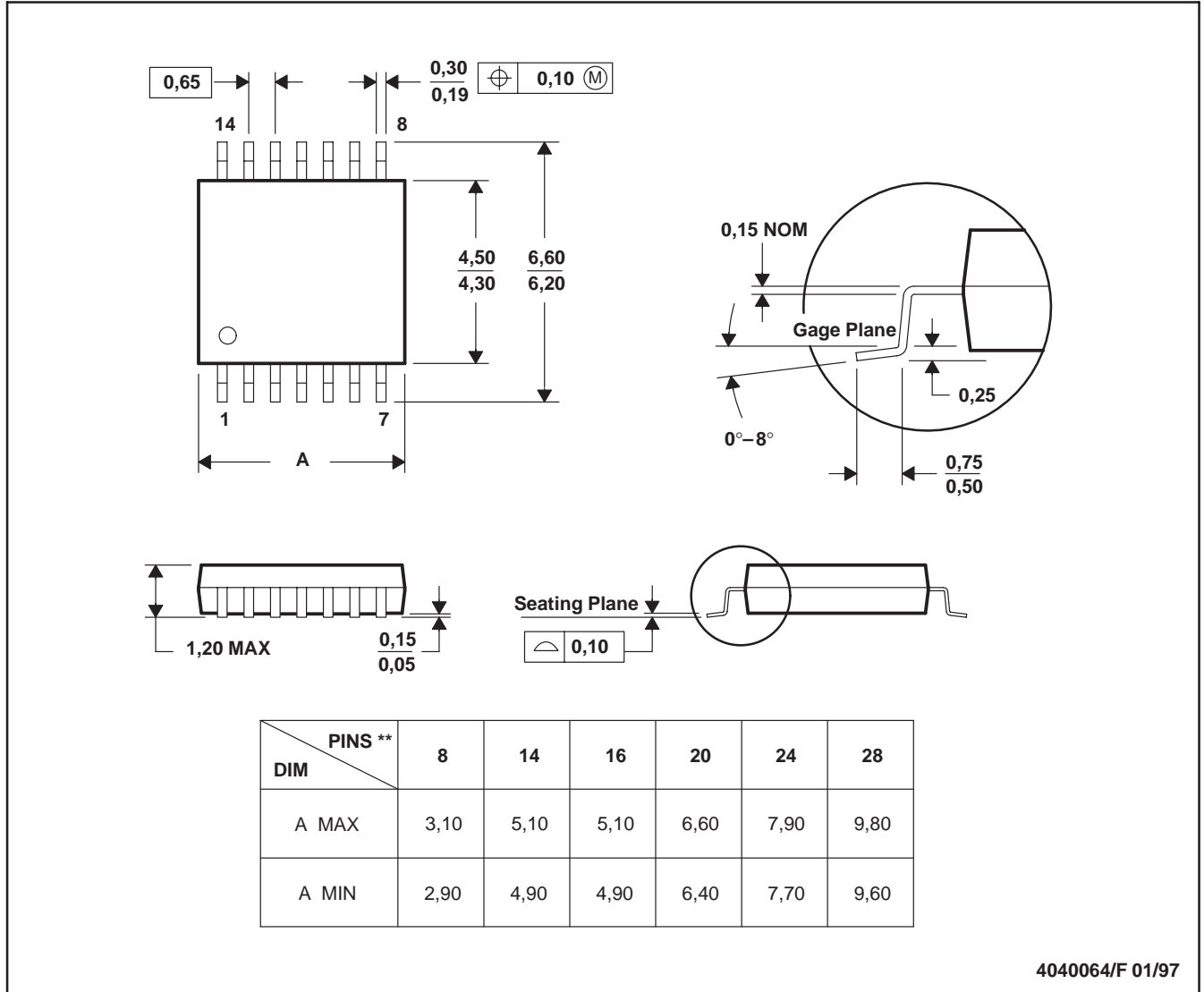

4040064/F 01/97

- NOTES:
- A. All linear dimensions are in millimeters.
 - B. This drawing is subject to change without notice.
 - C. Body dimensions do not include mold flash or protrusion not to exceed 0,15.
 - D. Falls within JEDEC MO-153

IMPORTANT NOTICE

Texas Instruments Incorporated and its subsidiaries (TI) reserve the right to make corrections, modifications, enhancements, improvements, and other changes to its products and services at any time and to discontinue any product or service without notice. Customers should obtain the latest relevant information before placing orders and should verify that such information is current and complete. All products are sold subject to TI's terms and conditions of sale supplied at the time of order acknowledgment.

TI warrants performance of its hardware products to the specifications applicable at the time of sale in accordance with TI's standard warranty. Testing and other quality control techniques are used to the extent TI deems necessary to support this warranty. Except where mandated by government requirements, testing of all parameters of each product is not necessarily performed.

TI assumes no liability for applications assistance or customer product design. Customers are responsible for their products and applications using TI components. To minimize the risks associated with customer products and applications, customers should provide adequate design and operating safeguards.

TI does not warrant or represent that any license, either express or implied, is granted under any TI patent right, copyright, mask work right, or other TI intellectual property right relating to any combination, machine, or process in which TI products or services are used. Information published by TI regarding third-party products or services does not constitute a license from TI to use such products or services or a warranty or endorsement thereof. Use of such information may require a license from a third party under the patents or other intellectual property of the third party, or a license from TI under the patents or other intellectual property of TI.

Reproduction of information in TI data books or data sheets is permissible only if reproduction is without alteration and is accompanied by all associated warranties, conditions, limitations, and notices. Reproduction of this information with alteration is an unfair and deceptive business practice. TI is not responsible or liable for such altered documentation.

Resale of TI products or services with statements different from or beyond the parameters stated by TI for that product or service voids all express and any implied warranties for the associated TI product or service and is an unfair and deceptive business practice. TI is not responsible or liable for any such statements.

Following are URLs where you can obtain information on other Texas Instruments products and application solutions:

Products		Applications	
Amplifiers	amplifier.ti.com	Audio	www.ti.com/audio
Data Converters	dataconverter.ti.com	Automotive	www.ti.com/automotive
DSP	dsp.ti.com	Broadband	www.ti.com/broadband
Interface	interface.ti.com	Digital Control	www.ti.com/digitalcontrol
Logic	logic.ti.com	Military	www.ti.com/military
Power Mgmt	power.ti.com	Optical Networking	www.ti.com/opticalnetwork
Microcontrollers	microcontroller.ti.com	Security	www.ti.com/security
		Telephony	www.ti.com/telephony
		Video & Imaging	www.ti.com/video
		Wireless	www.ti.com/wireless

Mailing Address: Texas Instruments
Post Office Box 655303 Dallas, Texas 75265