



TH71081

868/915MHz ASK Transmitter / LO Source

Features

- Fully integrated, PLL-stabilized VCO
- Flexible frequency range from 800 MHz to 930 MHz
- ASK achieved by on/off keying of internal power amplifier
- FM possible with external varactor
- Wide power supply range from 2.2 V to 5.5 V
- High over-all frequency accuracy
- Very low standby current
- Adjustable output power range from -15 dBm to +1 dBm
- Adjustable current consumption from 6.2 mA to 12.5 mA
- Differential output well-suited for loop antenna
- Conforms to EN 300 220 and similar standard

Ordering Information

Part No.	Temperature Range	Package
TH71081	-40 C° to 85 °C	SOIC8

Application Examples

- Keyless car and central locking
- Low-power telemetry
- Alarm and security systems
- General digital data transmission
- General analog audio signal transmission
- Local oscillator signal generation

Pin Description

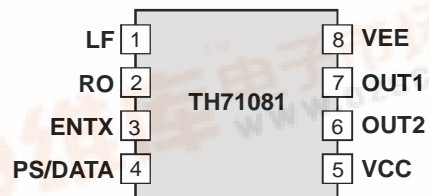

General Description

The TH71081 ASK transmitter IC is designed for applications in the European 868MHz industrial-scientific-medical (ISM) band, according to the EN 300 220 telecommunications standard. It can also be used for any other system with carrier frequencies ranging from 800 MHz to 930 MHz (e.g. for applications in the US 915MHz ISM band).

The transmitter's carrier frequency f_c is determined by the frequency of the reference crystal f_{ref} that is used. The integrated PLL synthesizer ensures that each RF value, ranging from 800 MHz to 930 MHz, can be achieved by using a crystal with reference frequency according to: $f_{ref} = f_c/N$, where $N = 32$ is the PLL feedback divider ratio.

Theory of Operation

General

As depicted in Fig.1, the TH71081 transmitter consists of a fully integrated voltage-controlled oscillator (VCO), a divide-by-32 divider (div32), a phase-frequency detector (PFD) and a charge pump. An external loop filter at pin LF determines the dynamic behaviour of the PLL and suppresses reference spurious signals.

The VCO's output signal feeds the power amplifier (PA). RF signal power P_o can be adjusted in six steps from $P_o = -15$ dBm to +1 dBm either by changing the value of resistor R_1 or by varying the voltage V_{PS} at pin PS/DATA. The open-collector differential output (OUT1, OUT2) can be used to either directly drive a loop antenna or to be converted to a single-ended impedance by means of a balanced-to-unbalanced (balun) transformer. For maximum available output power, the differential output should be matched to a load of approx. 1 k Ω .

Bandgap biasing ensures stable operation of the IC at a power supply range of 2.2 V to 5.5 V.

ASK Modulation

The TH71081 can be ASK-modulated by applying data directly at pin PS. This turns the PA on and off and therefore leads to an ASK signal at the output.

LO Source

Many applications require a stable RF source. For this purpose, the TH71081 can be used without modulation as an easy-to-use, PLL-stabilized, continuous wave (CW) generator.

Frequency Modulation (FM)

For FM operation an external varactor is required. It simply acts as a pulling capacitor connected in series to the crystal. Then the analog modulation signal, applied through a series resistor, directly modulates the XOSC.

Mode Control Logic

The mode control logic allows two different modes of operation as listed in the following table. The mode control pin ENTX is pulled-down internally. This guarantees that the whole circuit is shut down if this pin is left floating.

ENTX	Mode	Description
0	TX disabled	whole circuit in standby
1	TX enable	TX active

Table 1: Modes of operation

Block Diagram

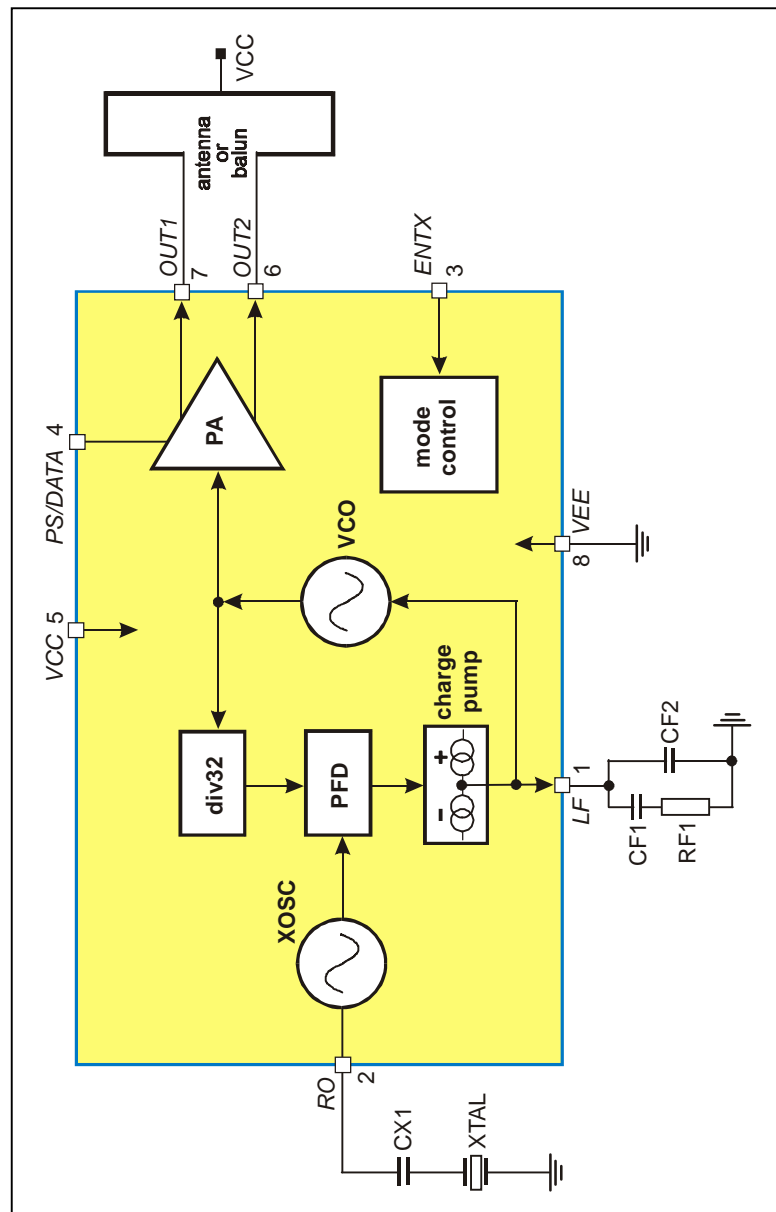
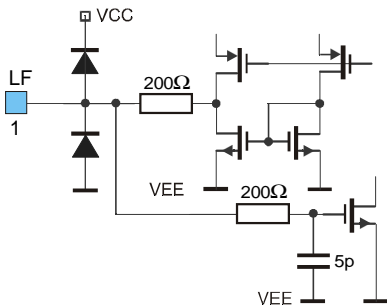
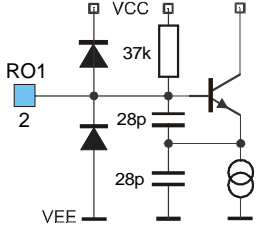
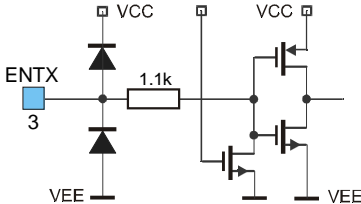
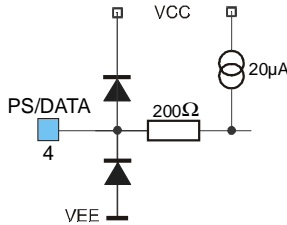
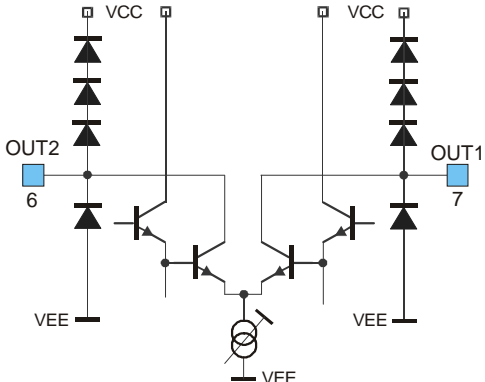

Fig. 1: TH71081 block diagram with external components

Pin Definition and Description

Pin No.	Name	I/O Type	Functional Schematic	Description
1	LF	analog I/O		connection to loop filter, charge pump output, VCO tuning input
2	RO	analog I/O		XOSC connection to XTAL, Colpitts type crystal oscillator
3	ENTX	input		mode control input, CMOS-compatible with internal pull-down
4	PS/DATA	analog I/O		power-select and ASK input, high-impedance comparator logic
5	VCC	supply		positive power supply
6	OUT2	output		differential power amplifier output, open collector
7	OUT1	output		differential power amplifier output, open collector
8	VEE	ground		negative power supply

Technical Data

Absolute Maximum Ratings

Parameter	Symbol	Condition	Min	Max	Unit
Supply voltage	V_{cc}		-0.3	7.0	V
Input voltage	V_{in}	ENTX pin	-0.3	VCC+0.3	V
Input current	I_{in}	ENTX pin	-1.0	1.0	mA
Storage temperature	T_{STG}		-40	150	°C
Electrostatic discharge	V_{ESD}	human body model, MIL STD 833D method 3015.7	-1.0	+1.0	kV

Normal Operating Conditions

Parameter	Symbol	Condition	Min	Max	Unit
Supply voltage	V_{cc}		2.2	5.5	V
Operating temperature	T_a		-40	85	°C
XOSC frequency	f_{ref}	set by the crystal	25	29	MHz
VCO frequency	f_c	$f_c = 32 \cdot f_{ref}$	800	930	MHz

DC Characteristics

all parameters under normal operating conditions, unless otherwise stated;
typical values at $T_a = 23\text{ °C}$ and $V_{cc} = 3\text{ V}$

Parameter	Symbol	Condition	Min	Typ	Max	Unit
Standby current	I_{SBY}	ENTX=0		0.05	0.1	μA
Operating current	I_{cc}	ENTX=1, $V_{PS}=1.1\text{V}$	8	10	11	mA
Input HIGH voltage	V_{HIGH}	ENTX pin	$0.7 \cdot V_{cc}$		$V_{cc}+0.3$	V
Input LOW voltage	V_{LOW}	ENTX pin	-0.3		$0.3 \cdot V_{cc}$	V
Input current	I_{in}	ENTX=0	-1		1	μA
Pull down current	I_{pd}	ENTX=1	2	8	15	μA

AC Characteristics

all parameters under normal operating conditions, unless otherwise stated;
 typical values at $T_a = 23\text{ °C}$ and $V_{cc} = 3\text{ V}$;
 $ENTX = 1$, $V_{PS} = 1.1\text{ V}$, $f_c = 868.3\text{ MHz}$, test circuit shown in Fig. 2

Parameter	Symbol	Condition	Min	Typ	Max	Unit
Output power	P_o			-2		dBm
FM deviation	Δf_{FM}	adjustable with varactor and V_{FM}		± 6		kHz
Modulation frequency FM	f_{mod}			5		kHz
Data rate ASK	R_{ASK}	NRZ		40		kbit/s
Reference spurs	P_{ref}	@ $f_c \pm f_{ref}$		-44		dBm
Harmonic content	P_{harm}	@ $2f_c, 3f_c, 4f_c$		-40		dBm
Spurious output signal	P_{off}	$V_{PS} \leq 0.1\text{ V}$		-60		dBm
Phase noise	PN	@ $f_c \pm 500\text{ kHz}$		-87		dBc/Hz
VCO gain	K_{VCO}			300		MHz/V
Charge pump current	I_{CP}			± 260		μA
Start-up time	t_{on}	from "all OFF" to any other mode			0.9	ms

Output Power Selection

typical values at $T_a = 23\text{ °C}$ and $V_{cc} = 3\text{ V}$;
 $ENTX = 1$, $f_c = 868.3\text{ MHz}$, test circuit shown in Fig. 2

R1 / k Ω	0	7.5	11	15	24	43
R2 / k Ω	∞	4.7	4.7	4.7	4.7	4.7
V_{PS} / V	≥ 2	1.1	0.9	0.7	0.5	0.3
I_{cc} / mA	12.5	9.5	8.5	7.8	7.0	6.2
P_o / dBm	1	-2	-5	-8	-12	-15
P_{harm} / dBm	≤ -40	≤ -40	≤ -40	≤ -45	≤ -45	≤ -50

If the transmitter is operated at any supply voltage V_{cc} ,
 the values for R_1 and R_2 can be calculated as follows:

$$R_1 = R_2 \cdot \left(\frac{V_{cc}}{V_{PS}} - 1 \right)$$

Crystal Parameter

Parameter	Symbol	Condition	Min	Max	Unit
Crystal frequency	$f_{crystal}$	fundamental mode, AT	25	29	MHz
Load capacitance	C_{load}		10	15	pF
Static capacitance	C_0			7	pF
Resonance resistance	R_m			40	Ω
Spurious response	a_{spur}			-10	dB

Test Circuit

Fig. 2: Test circuit for ASK with 50Ω matching network

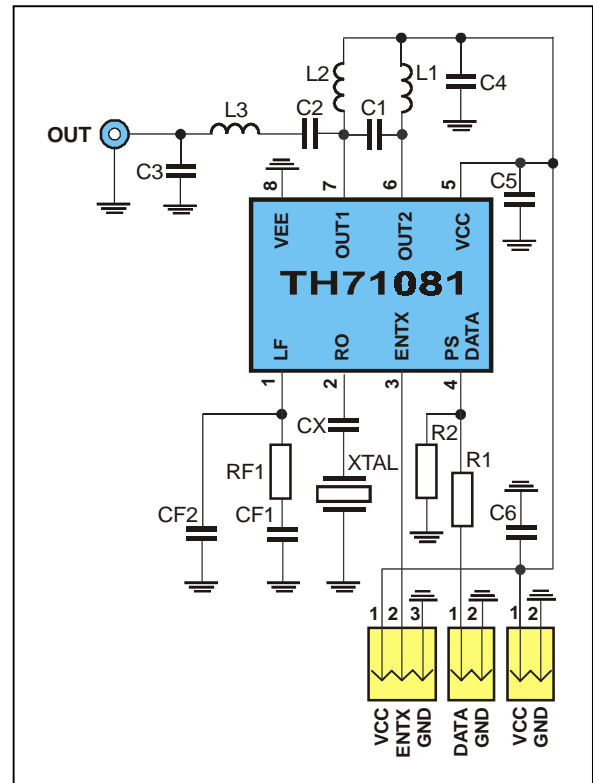

Test circuit component list to Fig. 2

Part	Size	Value	Tolerance	Description
CF1	0603	4.7 nF	±10%	loop filter capacitor
CF2	0603	56 pF	±10%	loop filter capacitor
CX	0603	18 pF	±10%	XOSC capacitor
C1	0603	0.68 pF	±5%	impedance matching capacitor
C2	0603	33 pF	±5%	impedance matching capacitor
C3	0805	2.2 pF	±5%	impedance matching capacitor
C4	0603	330 pF	±10%	blocking capacitor
C5	0603	330 pF	±10%	blocking capacitor
C6	0805	33 nF	±10%	blocking capacitor
L1	0603	8.2 nH	±5%	impedance matching inductor
L2	0603	15 nH	±5%	impedance matching inductor
L3	0603	22 nH	±5%	impedance matching inductor
RF1	0603	1.0 kΩ	±10%	loop filter resistor
R1	0603	See output power selection table	±10%	ASK power-select resistor, not requirement at CW mode
R2	0603	See output power selection table	±10%	ASK or CW mode power-select resistor
XTAL	HC49/S	27.1344 MHz fundamental wave	±30ppm calibration ±30ppm temp.	crystal, $C_{load} = 12 \text{ pF to } 15 \text{ pF}$, $C_{0, max} = 7 \text{ pF}$, $R_{m, max} = 40 \text{ } \Omega$

Package Information

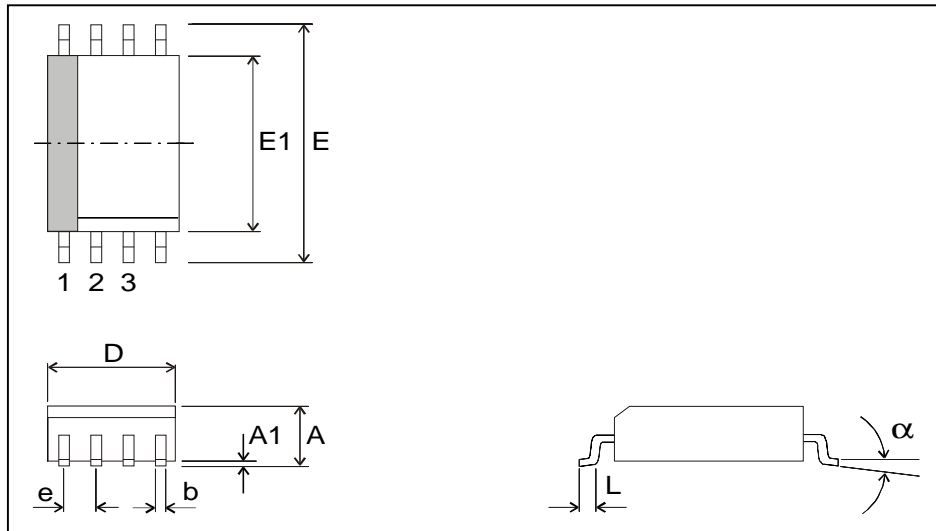

Fig. 6: SOIC8 (Small Outline Package)

all Dimension in mm, coplanarity < 0.1mm									
	D	E1	E	A	A1	e	b	L	α
min	4.80	3.81	5.80	1.32	0.10	1.27	0.36	0.41	0°
max	4.98	3.99	6.20	1.72	0.25		0.46	1.27	8°
all Dimension in inch, coplanarity < 0.004"									
min	0.189	0.150	0.2284	0.060	0.0040	0.05	0.014	0.016	0°
max	0.196	0.157	0.2440	0.068	0.0098		0.018	0.050	8°

Your Notes

Your Notes

Important Notice

Devices sold by Melexis are covered by the warranty and patent indemnification provisions appearing in its Term of Sale. Melexis makes no warranty, express, statutory, implied, or by description regarding the information set forth herein or regarding the freedom of the described devices from patent infringement. Melexis reserves the right to change specifications and prices at any time and without notice. Therefore, prior to designing this product into a system, it is necessary to check with Melexis for current information. This product is intended for use in normal commercial applications. Applications requiring extended temperature range, unusual environmental requirements, or high reliability applications, such as military, medical life-support or life-sustaining equipment are specifically not recommended without additional processing by Melexis for each application.

The information furnished by Melexis is believed to be correct and accurate. However, Melexis shall not be liable to recipient or any third party for any damages, including but not limited to personal injury, property damage, loss of profits, loss of use, interrupt of business or indirect, special incidental or consequential damages, of any kind, in connection with or arising out of the furnishing, performance or use of the technical data herein. No obligation or liability to recipient or any third party shall arise or flow out of Melexis' rendering of technical or other services.

© 2000 Melexis NV. All rights reserved.

For the latest version of this document. Go to our website at
www.melexis.com

Or for additional information contact Melexis Direct:

Europe and Japan:
Phone: +32 1361 1631
E-mail: sales_europe@melexis.com

All other locations:
Phone: +1 603 223 2362
E-mail: sales_usa@melexis.com