

Audio Analog Switch

FEATURES

- Wide Operating Voltage Range (2 to 14 V)
- Low Distortion (typ. 0.004%)
- Wide Dynamic Range (typ. 6 V_{P-P})
- Low Output Impedance (typ. 20 Ω)
- Low Switching Noise (typ. 3 mV)
- Output Parallel Connection Possible

APPLICATIONS

- Audio Systems
- Radio Cassettes

DESCRIPTION

The TK15327M is an Analog Switch IC that was developed for audio frequency. The function is to select one output from two inputs and has a floating position too. The channel can be changed by two control levels and the device includes two circuits. The TK15327M has a mono-power supply and the input bias is a built-in type ($V_{CC}/2V$). Because the distortion is very low, the TK15327M fits various signals switching. It is best suited for Hi-Fi devices. Operating voltage is wide, the circuit plan is simple. The TK15327M is available in a small plastic surface mount package (SSOP-12).

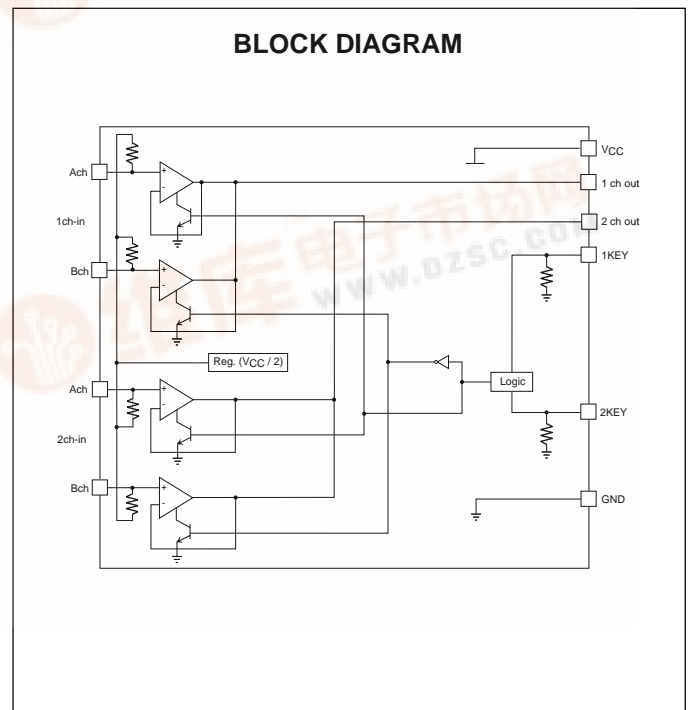
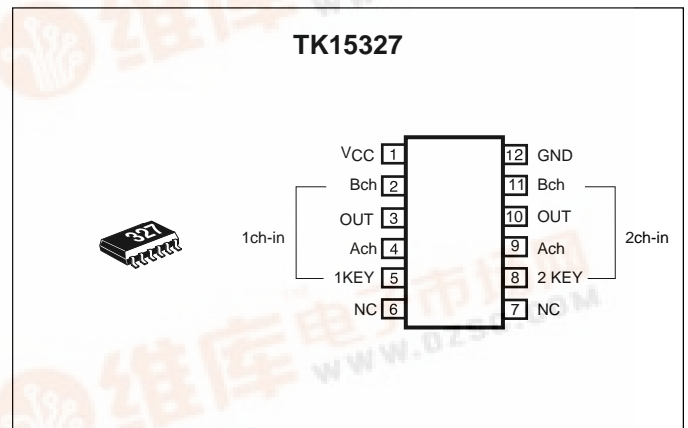

ORDERING INFORMATION

TK15327M □□

└─ Tape/Reel Code

TAPE/REEL CODE
TL: Tape Left



TK15327

ABSOLUTE MAXIMUM RATINGS

Supply Voltage 15 V
 Power Dissipation (Note 4) 350 mW
 Storage Temperature Range -55 to +150 °C
 Operating Temperature Range -20 to +75 °C
CONTROL SECTION
 Input Voltage -0.3 V to $V_{CC} + 0.3$ V

ANALOG SWITCH SECTION
 Signal Input Voltage -0.3 V to $V_{CC} + 0.3$ V
 Signal Output Current 3 mA
 Operating Voltage Range 2 to 14 V
 Maximum Input Frequency 100 kHz

TK15327M ELECTRICAL CHARACTERISTICS

Test conditions: $V_{CC} = 8.0$ V, $T_A = 25$ °C, unless otherwise specified.

SYMBOL	PARAMETER	TEST CONDITIONS	MIN	TYP	MAX	UNITS
I_{CC}	Supply Current			4.2	6.5	mA
KEY CONTROL SECTION						
V_{IL}	Input Voltage Low Level	Note 1	-0.3		+0.8	V
V_{IH}	Input Voltage High Level		1.8		$V_{CC} + 0.3$	V
Z_{IN}	Input Impedance			50		k Ω
ANALOG SWITCH SECTION						
THD	Total Harmonic Distortion	$V_{IN} = 1$ Vrms, $f = 1$ kHz		0.004	0.008	%
N_L	Residual Noise	Note 2			10	μ Vrms
ISO	Isolation	$V_{IN} = 1$ Vrms, $F = 10$ kHz, Note 3			-75	dB
SEP	Separation	$V_{IN} = 1$ Vrms, $f = 10$ kHz, Note 3			-80	dB
DYN	Maximum Input Signal Level	$f = 1$ kHz, THD = 0.1%	2.0			Vrms
GVA	Voltage Gain	$f = \sim 20$ kHz		0		dB
V_{cent}	Input-Output Terminal Voltage	$V_{CC} / 2$ output	3.8	4.0	4.2	V
ΔV_{cent}	Output Terminal Voltage Difference	Between same channel		3	13	mV
R_{IN}	Input Bias Resistance			65		μ A
Z_{OUT}	Output Impedance	DC Impedance		20		Ω

Note 1: The KEY input equivalent circuit is shown to the right.

1 channel and 2 channel is the separate action by 1Key pin and 2 key pin. When the control pin is open, it is outputted high level (about 1.4 V). Then the A channel input signal is outputted. The change is carried out at low level.

Note 2: The specification means a value as measurement-input terminal connects to ground through a capacitor.

Note 3: ISO is a cross talk between A channel and B channel, SEP is a cross talk between 1 channel and 2 channel. The specification means a value as measurement-input terminal connects to ground through 10 k Ω resistor and capacitor.

Note 4: Power dissipation is 350 mW when mounted as recommended. Derate at 3.0 mW/°C for operation above 25°C.

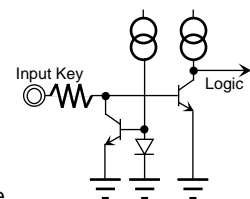

TEST CIRCUITS AND METHODS

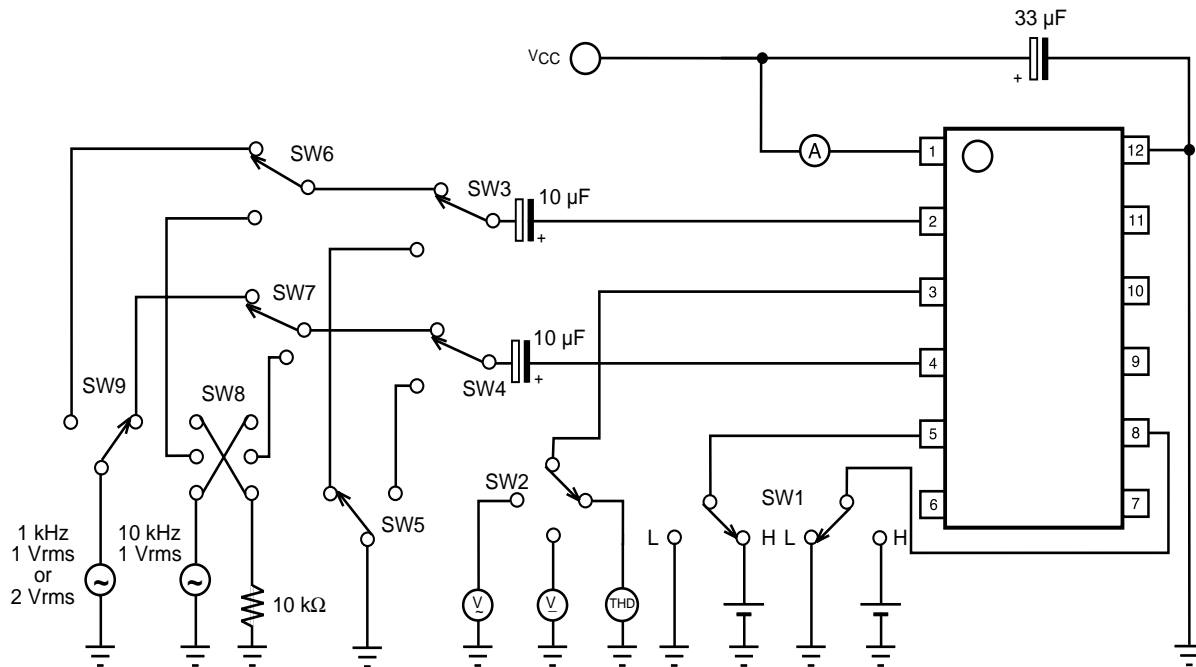

- 1: The above condition represents 1 ch.
- 2: The above conditions distortion rate of 1-Ach and dynamic range measurement.
- 3: SW5 is for residual noise measurement.
- 4: SW8 is for cross talk (ISO or SEP) measurement.

SUPPLY CURRENT (FIGURE 1)

This current is a consumption current with a nonloading condition.

- 1) Connect Pin 5 to V_{CC} , Pin 8 is low level or open.
- 1) Measure the inflow current to Pin 1 from V_{CC} . This current is the supply current.

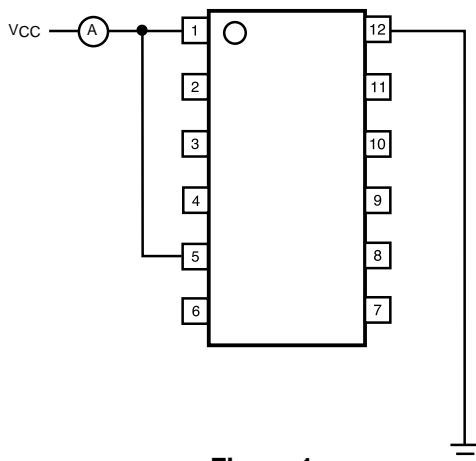

Figure 1

CONTROL LOW/HIGH LEVEL (FIGURE 2)

This level is to measure the threshold level.

- 1) Input, the V_{CC} to Pin 1. (This condition is the same with other measurements, omitted from the next for simplicity)
- 2) Input to Pin 4 with sine wave ($f = 1 \text{ kHz}$, $V_{IN} = 1 \text{ Vrms}$).
- 3) Connect an oscilloscope to Pin 3.
- 4) Elevate the control voltage from 0 V gradually (Pin 8 is low level or open), until the sine wave appears at the oscilloscope. This voltage is the threshold level when the wave appears.

TEST CIRCUITS AND METHODS (CONT.)

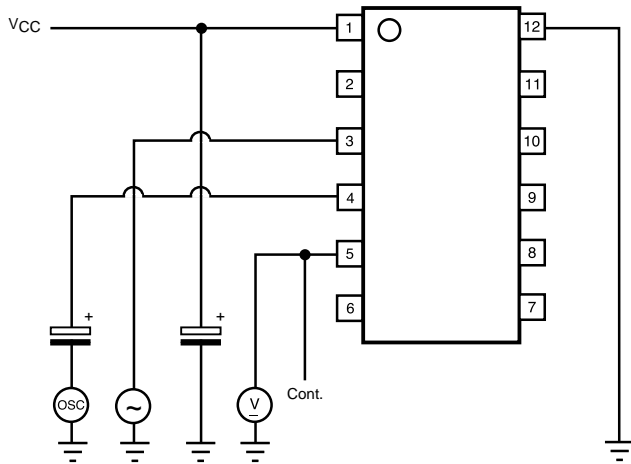

Figure 2

CONTROL INPUT IMPEDANCE (FIGURE 3)

This is the input resistance of control terminals.

- 1) Measure the inflow current from V_{CC} to Pin 5.
- 2) Calculate:

$$IMP = V_{CC} / \text{Inflow Current}$$

This resistance is the input impedance.

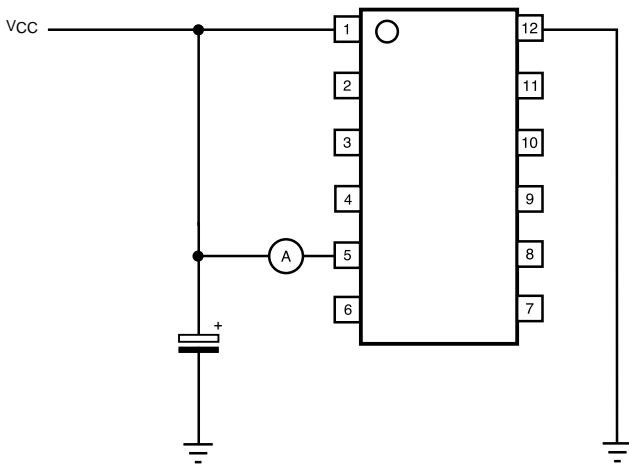

Figure 3

TOTAL HARMONIC DISTORTION (FIGURE 4)

Use the lower distortion oscillator for this measurement because distortion of the TK15327 is very low.

- 1) Connect V_{CC} to Pin 5, Pin 8 is low level or open.
- 2) Connect a distortion analyzer to Pin 3.
- 3) Input the sine wave (1 kHz, 1 Vrms) to Pin 4.
- 4) Measure the distortion of Pin 3. This value is the distortion of 1-Ach.
- 5) Next, reverse conditions at Pin 5 and Pin 8.
- 6) Input the same sine wave to Pin 2.
- 7) Measure in the same way. This value is the distortion of 1-Bch.

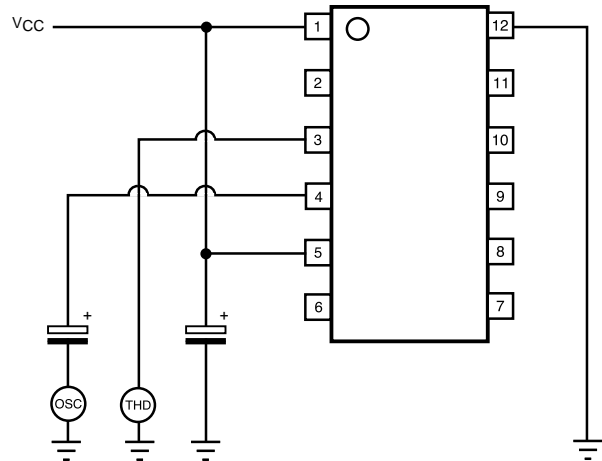

Figure 4

VOLTAGE GAIN (FIGURE 5)

This is the output level against input level.

- 1) Connect V_{CC} to Pin 5, Pin 8 is low level or open.
- 2) Connect AC volt meters to Pin 4 and Pin 3.
(Using the same type meter is best)
- 3) Input a sine wave ($f = \text{max. } 20 \text{ kHz}$, 1 Vrms) to Pin 4.
- 4) Measure the level of Pin 4 and name this V1.
- 5) Measure the level of Pin 3 and name this V2.
- 6) Calculate Gain = $20 \text{ Log } ((|V2 - V1|) / V1)$
 $V1 < V2 + \text{Gain}$, $V1 > V2 - \text{Gain}$
This value is the voltage gain of 1-Ach.
- 7) Next, reverse conditions at Pin 5 and Pin 8.
- 8) Input the same sine wave to Pin 2.
- 9) Measure and calculate in the same way.
This value is the voltage gain of 1-Bch.

TEST CIRCUITS AND METHODS (CONT.)

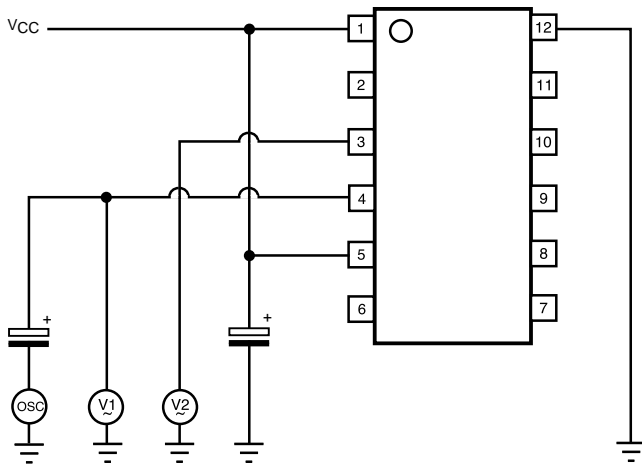

Figure 5

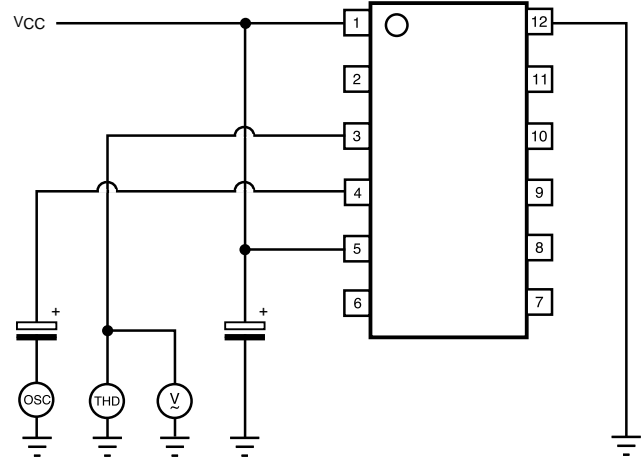

Figure 6

MAXIMUM INPUT LEVEL (FIGURE 6)

This measurement measures at output side.

- 1) Connect V_{CC} to Pin 5, Pin 8 is low level or open.
- 2) Connect a distortion analyzer and an AC voltmeter to Pin 3.
- 3) Input a sine wave (1 kHz) to Pin 4 and elevate the voltage gradually until the distortion gets to 0.1%.
- 4) When the distortion amounts to 0.1%, stop elevating and measure the AC level of Pin 3.
This value is the maximum input level of 1-Ach.
- 5) Next, reverse conditions at Pin 5 and Pin 8.
- 6) Input the same sine wave to Pin 2.
- 7) Measure in the same way.
This value is the maximum input level of 1-Bch.

RESIDUAL NOISE (FIGURE 7)

This value is not S/N ratio. This is a noise which occurs from the device itself.

- 1) Connect V_{CC} to Pin 5, Pin 8 is low level or open.
- 2) Connect an AC voltmeter to Pin 3.
- 3) Connect a capacitor from Pin 4 to GND.
- 4) Measure AC voltage of Pin 3. This value is the noise of 1-Ach. If the influence of noise from outside exists, use optional filters.
- 5) Next, reverse conditions at Pin 5 and Pin 8.
- 6) Connect to GND through a capacitor from Pin 2.
- 7) Measure in the same way.
This value is the noise level of 1-Bch.

TEST CIRCUITS AND METHODS (CONT.)

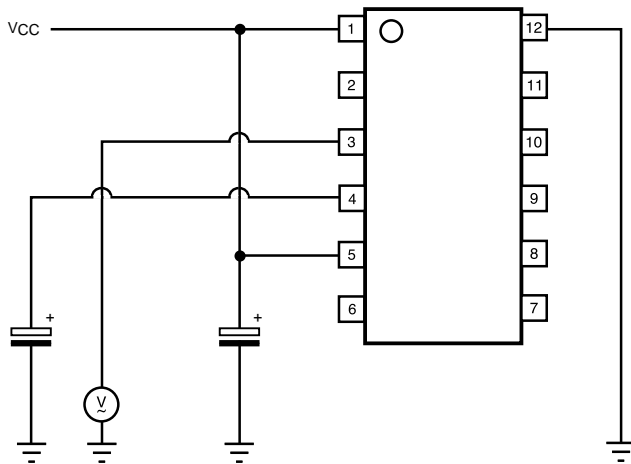

Figure 7

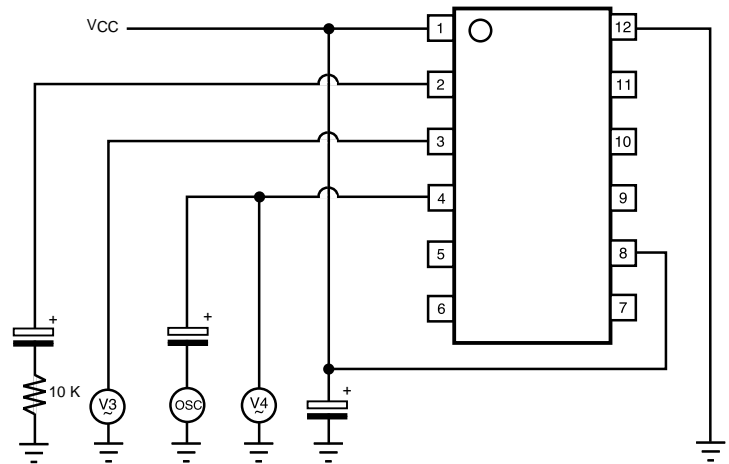

Figure 8

ISOLATION (FIGURE 8)

This is the cross talk between Ach and Bch.

- 1) Connect V_{CC} to Pin 8, Pin 5 is low level or open.
- 2) Connect AC volt meters to Pin 4 and Pin 3.
- 3) Connect a capacitor and a resistance in series to GND from Pin 2.
- 4) Input a sine wave (10 kHz, 1 Vrms) to Pin 4.
- 5) Measure the level of Pin 4 and name this V4.
- 6) Measure the level of Pin 3 and name this V3.
- 7) Calculate:

$$ISO = 20 \text{ Log } (V3 / V4)$$
 This value is the isolation to Bch from Ach.
- 8) Next, reverse conditions at Pin 5 and Pin 8.
- 9) Change line of Pin 2 and Pin 4.
- 10) Input the same sine wave to Pin 2.
- 11) Measure and calculate in the same way.
 This value is the isolation to Ach from Bch.

SEPARATION (FIGURE 9)

This is the cross talk between 1ch and 2ch.

- 1) Connect either Pin 5 or Pin 8 to V_{CC} . One side pin is low level or open.
- 2) Connect AC volt meters to Pin 4 (or Pin 2) and Pin 10.
- 3) Connect Pin 9 and Pin 11 to GND through capacitors and a resistance.
- 4) Input a sine wave (10 kHz, 1 Vrms) to Pin 2 and Pin 4.
- 5) Measure the level of Pin 4 and name this V5.
- 6) Measure the level of Pin 10 and name this V6.
- 7) Calculate:

$$SEP = 20 \text{ Log } (V6 / V5)$$
 This value is the separation to 2ch from 1ch.

TEST CIRCUITS AND METHODS (CONT.)

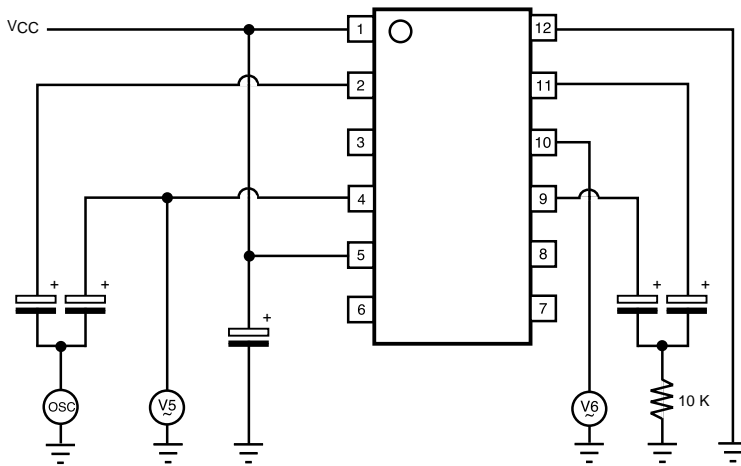

Figure 9

OUTPUT TERMINAL DIFFERENCE

This is the DC output voltage difference between Ach and Bch. This is calculated by using values measured at the I/O Terminal Voltage.

$$\Delta V_{cent} = | (1 - A_{ch} \text{ value}) - (1 - B_{ch} \text{ value}) |$$

This value is the voltage difference of 1 ch.

I/O TERMINAL VOLTAGE (FIGURE 10)

This is the DC voltage of input and output. Because the input and the output are nearly equal, only the output is measured.

- 1) Connect V_{CC} to Pin 5, Pin 8 is low level or open.
- 2) Connect a DC volt meter to Pin 3 and measure.
This value is the terminal voltage of 1-Ach.
- 3) Next, reverse conditions at Pin 5 and Pin 8.
- 4) Measure in the same way.
This value is the terminal voltage of 1-Bch.

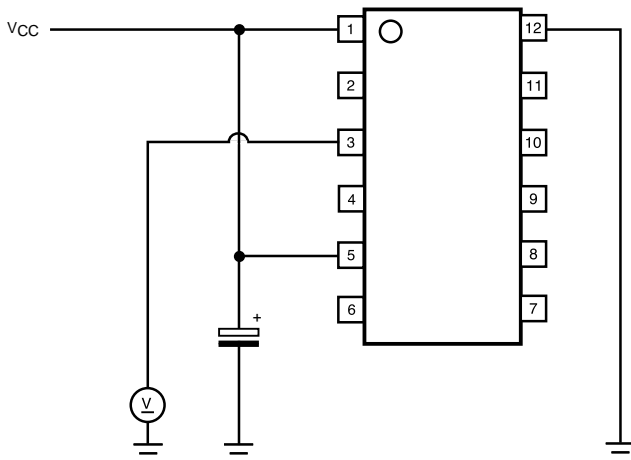
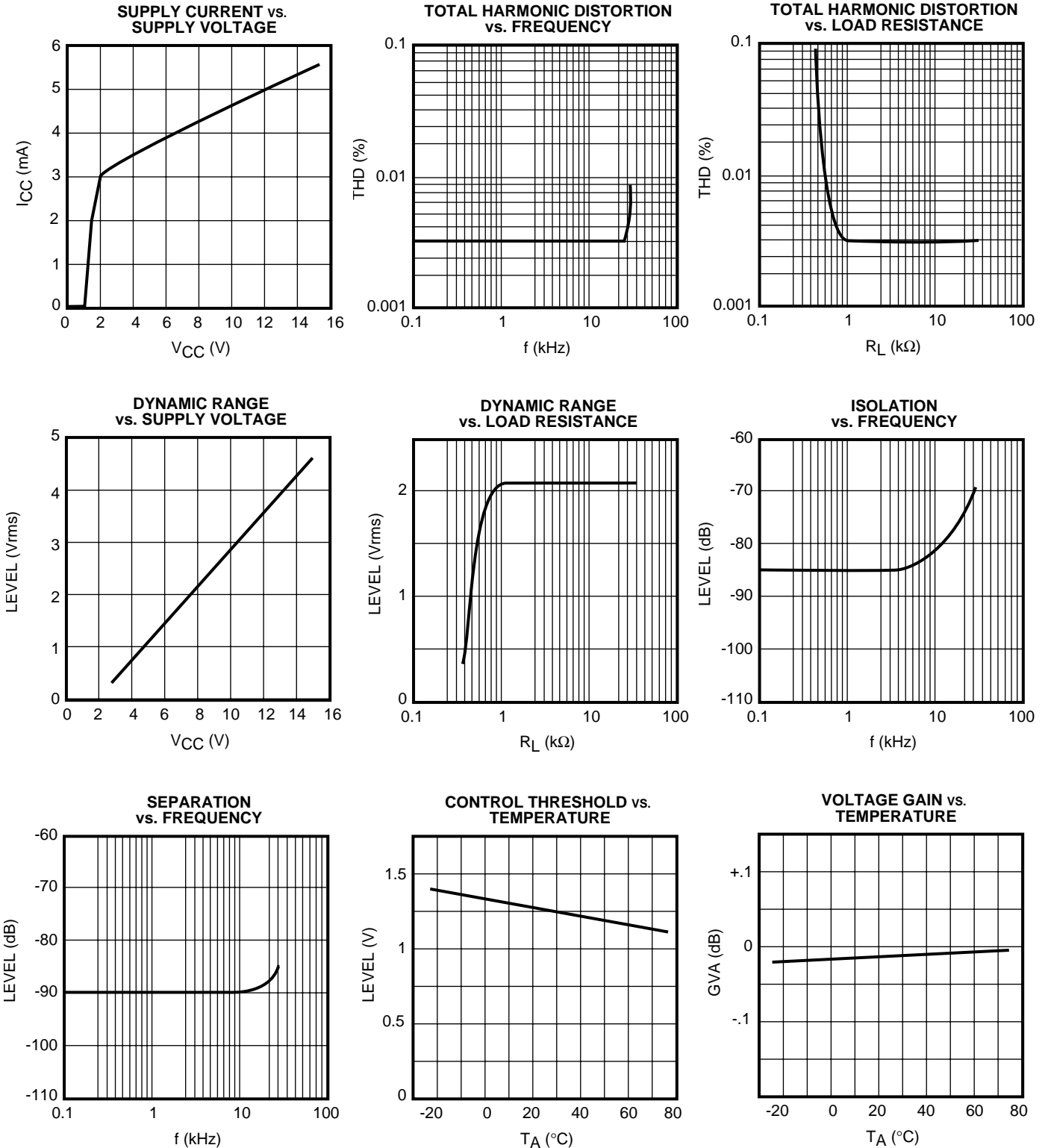

Figure 10

TYPICAL PERFORMANCE CHARACTERISTICS

$V_{CC} = 8\text{ V}$, $T_A = 25\text{ }^\circ\text{C}$, unless otherwise specified.



TYPICAL PERFORMANCE CHARACTERISTICS (CONT.)

$V_{CC} = 8\text{ V}$, $T_A = 25\text{ }^\circ\text{C}$, unless otherwise specified.

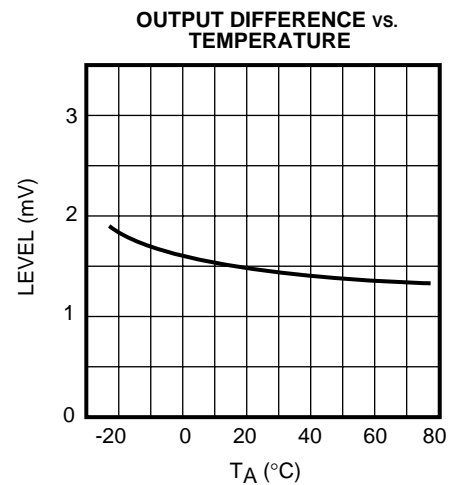
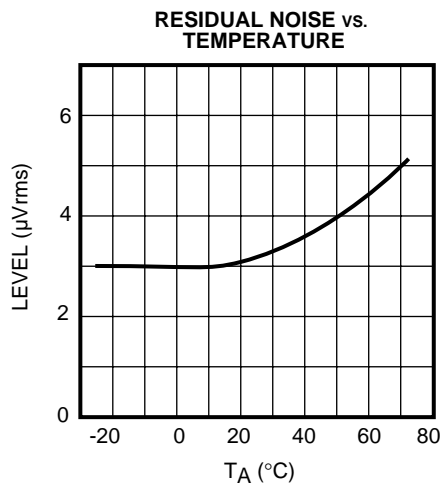

TERMINAL VOLTAGE AND CIRCUIT

Condition: $V_{CC} = 8\text{ V}$.

PIN NO.	ASSIGNMENT	DC VOLTAGE	CIRCUIT/FUNCTION
1	V_{CC}	8 V	Supply Voltage Pin
2 4 9 11	IN A, IN B	4 V	<p>Signal Input Pin</p>
3 10	OUT Pin 5 and Pin 8 Condition	Floating	<p>Signal Output Pin</p>
5 8	KEY	0 V	<p>Control Pin</p>
12	GND	0 V	Ground Pin
6 7	NC	Floating	No Contact Pin

APPLICATION INFORMATION

KEY INPUT CIRCUIT

1ch and 2ch is separate action by each control keys. Figure 11 is an equivalence circuit of key input. If two keys are low level or high level at the same time then the output is floating condition. (See Terminal DC Voltage and Circuit table on page 9).

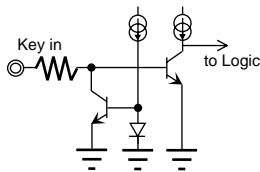

Figure 11

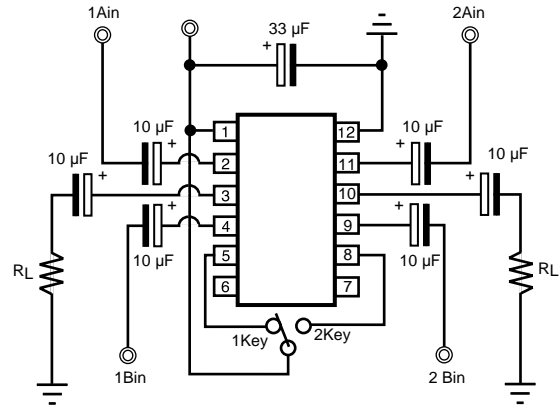

Figure 13

SWITCHING TIME

This time is the signal change response time compared to the control key input signal. Figure 12 illustrates the timing chart. $T = 2 \mu s$ typically.

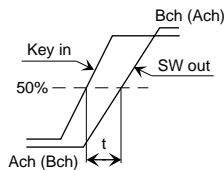

Figure 12

APPLICATION

Figure 13 illustrates an example of a typical application. The standard application is to use capacitor coupling at the inputs and output of the TK15327M. For characteristics of distortion and dynamic range versus R_L , refer to the graphs in the Typical Performance Characteristics. The TK15327M can also be used with direct coupling, but the characteristics will get worse (distortion, etc.). If direct coupling is desired, then it is recommended to use external circuitry that is biased compatible with the TK15329M. Input of the TK15329M is the open base type.

CROSS TALK (ISOLATION AND SEPARATION)

Figure 14 is an example of a layout pattern. In the application of the TK15327M, the following must be considered. Because of the high impedance at the inputs, the capacitors can act as antennas to each other. If the parts are bigger, and the space between the capacitors is too narrow, then cross talk will increase. Therefore, when designing the printed circuit pattern, separate the input capacitors as far as possible and use as small a part as possible (e.g., surface mount types, etc.).

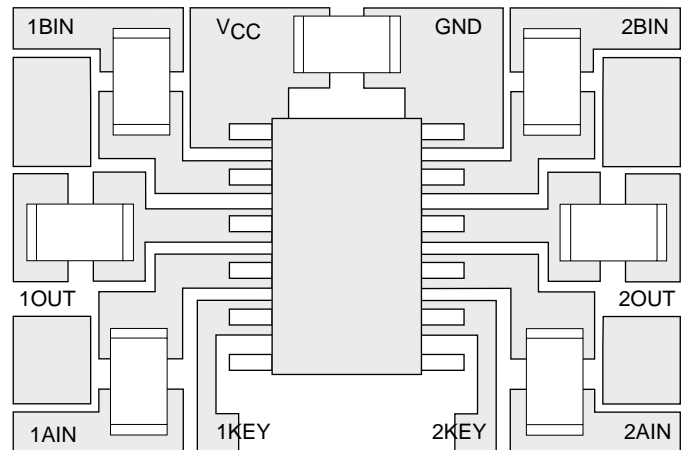

Figure 14

APPLICATION INFORMATION (CONT.)

OUTPUT TERMINAL VOLTAGE DIFFERENCE

This parameter is the output voltage difference between Ach and Bch, and appears when the channel changes from Ach to Bch, or changes to the reverse. Generally, this is called Switching Noise or Pop Noise. If this value is big and if this noise is amplified by the final amplifier and is outputted by the speakers, then it appears as a Shock Sound. Output terminal voltage difference of the TK15327M is a value that adds the internal bias difference and the offset voltage difference. The value of the TK15327M is very small; its maximum value is 13 mV. Toko can offer the "Muting IC" if users wish to mute Switching Noise.

DIRECT TOUCH

The signal input terminals:

Internal circuits are operated by constant current circuit, even if V_{CC} or GND is contacted, damage does not occur.

The signal output terminal:

Outflow or inflow current is decided by ability of final transistor, but protection circuit is not attached. If GND or V_{CC} are contacted damage may occur. Pay attention to long time contact. Do not supply over the maximum rating. Referenced to GND, do not provide to all terminals over $V_{CC} + 0.3$ V or -0.3 V.

DC SIGNAL INPUT

The output of the TK15327M has a saturation voltage (both V_{CC} and GND sides about 1.0 V); accordingly the use of a DC signal is not recommend (e.g., the pulse signal etc.)

NC TERMINAL

NC terminals are not wired inside IC by bonding wire. NC terminals are not tested so do not connect at outside.

FLOATING POSITION

TK15327 has floating position and can increase optional channels. Figure 15 is an example to select one output from four inputs, and the change operates by four controls. This function is shown in the table below. If channels increase more, control keys will increase with the same number too. In this case the Decoder may be necessary. Each device and channel has individual output voltage values within a specification. When channels are increased caution the output terminal voltage difference too.

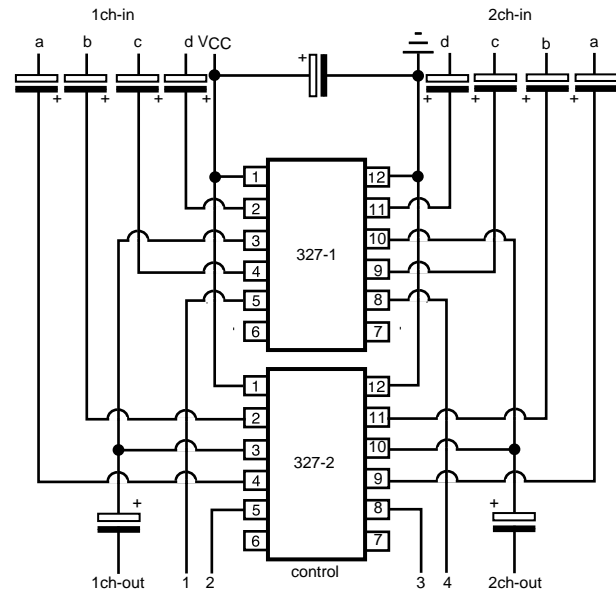
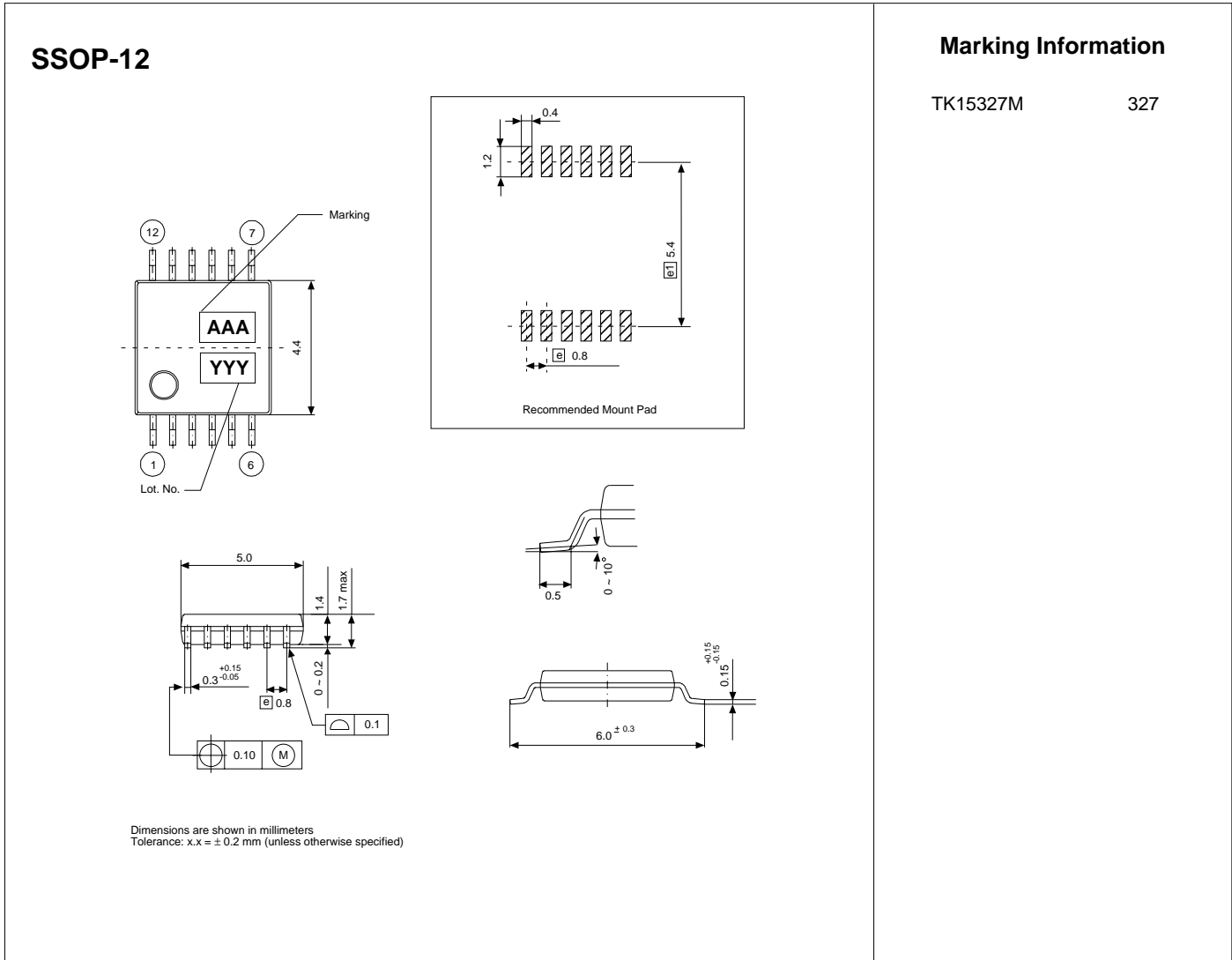

Figure 15

KEY NO. / OUTPUT	1	2	3	4
c	H	L	L	L
a	L	H	L	L
b	L	L	H	L
d	L	L	L	H

When all is high level or low level, output is the floating. Plural high level is prohibited.

PACKAGE OUTLINE



Toko America, Inc. Headquarters
 1250 Feehanville Drive, Mount Prospect, Illinois 60056
 Tel: (847) 297-0070 Fax: (847) 699-7864

TOKO AMERICA REGIONAL OFFICES

Midwest Regional Office
 Toko America, Inc.
 1250 Feehanville Drive
 Mount Prospect, IL 60056
 Tel: (847) 297-0070
 Fax: (847) 699-7864

Western Regional Office
 Toko America, Inc.
 2480 North First Street, Suite 260
 San Jose, CA 95131
 Tel: (408) 432-8281
 Fax: (408) 943-9790

Eastern Regional Office
 Toko America, Inc.
 107 Mill Plain Road
 Danbury, CT 06811
 Tel: (203) 748-6871
 Fax: (203) 797-1223

Semiconductor Technical Support
 Toko Design Center
 4755 Forge Road
 Colorado Springs, CO 80907
 Tel: (719) 528-2200
 Fax: (719) 528-2375

Visit our Internet site at <http://www.tokoam.com>

The information furnished by TOKO, Inc. is believed to be accurate and reliable. However, TOKO reserves the right to make changes or improvements in the design, specification or manufacture of its products without further notice. TOKO does not assume any liability arising from the application or use of any product or circuit described herein, nor for any infringements of patents or other rights of third parties which may result from the use of its products. No license is granted by implication or otherwise under any patent or patent rights of TOKO, Inc.