

- **Very Low Power Consumption . . . 2 mW Typ at $V_{DD} = 5\text{ V}$**
- **Capable of Operation in Astable Mode**
- **CMOS Output Capable of Swinging Rail to Rail**
- **High Output-Current Capability**
Sink 100 mA Typ
Source 10 mA Typ
- **Output Fully Compatible With CMOS, TTL, and MOS**
- **Low Supply Current Reduces Spikes During Output Transitions**
- **Single-Supply Operation From 2 V to 15 V**
- **Functionally interchangeable With the NE556; Has Same Pinout**

description

The TLC556 series are monolithic timing circuits fabricated using the TI LinCMOS™ process, which provides full compatibility with CMOS, TTL, and MOS logic and operates at frequencies up to 2 MHz. Accurate time delays and oscillations are possible with smaller, less-expensive timing capacitors than the NE556 because of the high input impedance. Power consumption is low across the full range of power supply voltages.

Like the NE556, the TLC556 has a trigger level approximately one-third of the supply voltage and a threshold level approximately two-thirds of the supply voltage. These levels can be altered by use of the control voltage terminal. When the trigger input falls below the trigger level, the flip-flop is set and the output goes high. If the trigger input is above the trigger level and the threshold input is above the threshold level, the flip-flop is reset and the output is low. The reset input can override all other inputs and can be used to initiate a new timing cycle. If the reset input is low, the flip-flop is reset and the output is low. Whenever the output is low, a low-impedance path is provided between the discharge terminal and ground.

While the CMOS output is capable of sinking over 100 mA and sourcing over 10 mA, the TLC556 exhibits greatly reduced supply-current spikes during output transitions. This minimizes the need for the large decoupling capacitors required by the NE556.

These devices have internal electrostatic-discharge (ESD) protection circuits that prevent catastrophic failures at voltages up to 2000 V as tested under MIL-STD-883C, Method 3015. However, care should be exercised in handling these devices, as exposure to ESD may result in degradation of the device parametric performance.

All unused inputs should be tied to an appropriate logic level to prevent false triggering.

The TLC556C is characterized for operation from 0°C to 70°C. The TLC556I is characterized for operation from -40°C to 85°C. The TLC556M is characterized for operation over the full military temperature range of -55°C to 125°C.

**D, J, OR N PACKAGE
(TOP VIEW)**

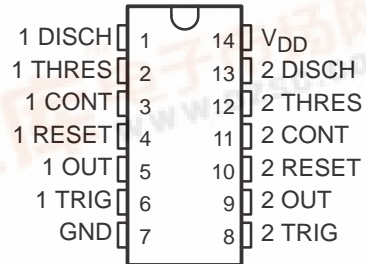

**FK PACKAGE
(TOP VIEW)**

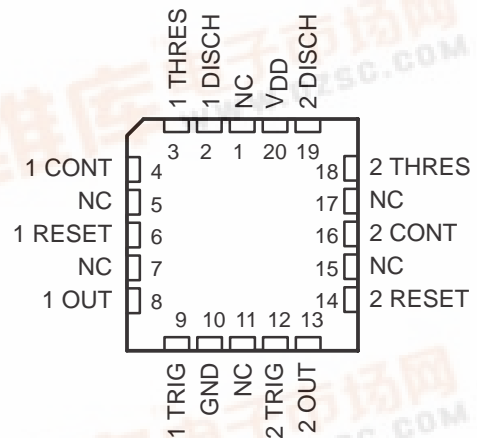

NC—No internal connection



TLC556, TLC556Y DUAL LinCMOS™ TIMERS

SLFS047B – FEBRUARY 1984 – REVISED SEPTEMBER 1997

AVAILABLE OPTIONS

T _A RANGE	V _{DD} RANGE	PACKAGE				CHIP FORM (Y)
		SMALL OUTLINE (D)	CHIP CARRIER (FK)	CERAMIC DIP (J)	PLASTIC DIP (N)	
0°C to 70°C	2 V to 18 V	TLC556CD			TLC556CN	TLC556Y
-40°C to 85°C	3 V to 18 V	TLC556ID			TLC556IN	
-55°C to 125°C	5 V to 18 V	TLC556MD	TLC556MFK	TLC556MJ	TLC556MN	

The D package is available taped and reeled. Add the suffix R to the device type (e.g., TLC556CDR).

FUNCTION TABLE

RESET VOLTAGE†	TRIGGER VOLTAGE†	THRESHOLD VOLTAGE†	OUTPUT	DISCHARGE SWITCH
< MIN	Irrelevant	Irrelevant	L	On
> MAX	< MIN	Irrelevant	H	Off
>MAX	>MAX	>MAX	L	On
> MAX	> MAX	< MIN	As previously established	

† For conditions shown as MIN or MAX, use the appropriate value specified under electrical characteristics.

functional block diagram (each timer)

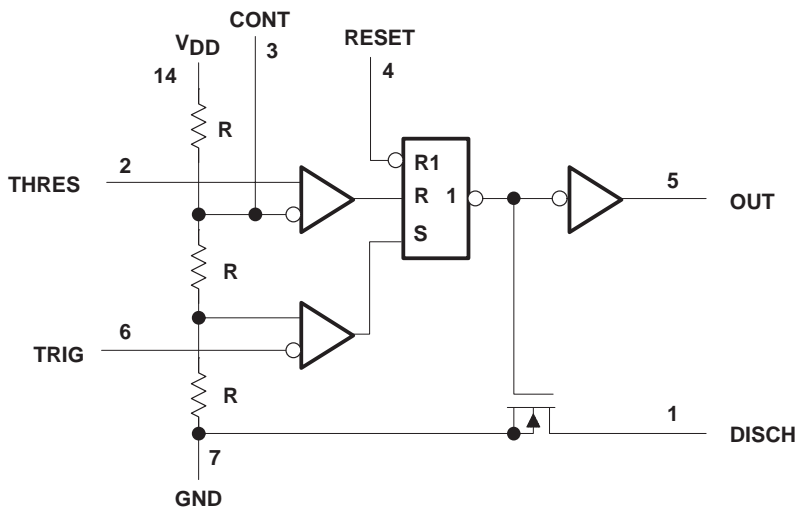

RESET can override TRIG and THRES.
TRIG can override THRES.

Pin numbers shown are for the D, J, or N packages.

TLC556, TLC556Y DUAL LinCMOS™ TIMERS

SLFS047B – FEBRUARY 1984 – REVISED SEPTEMBER 1997

TLC556Y chip information

These chips, properly assembled, display characteristics similar to the TLC556 (see electrical table). Thermal compression or ultrasonic bonding may be used on the doped aluminum bonding pads. Chips may be mounted with conductive epoxy or a gold-silicon preform.

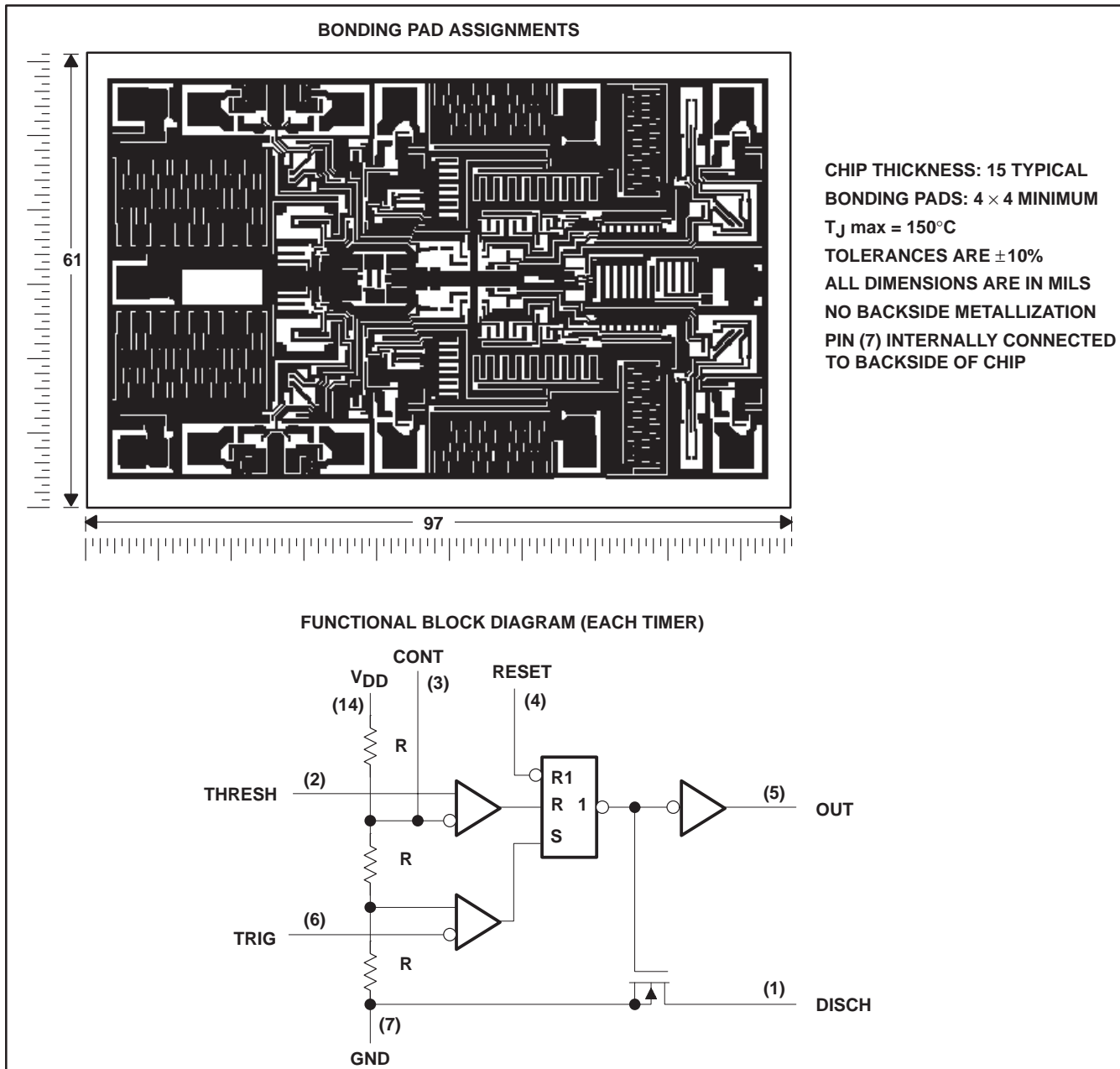

TLC556, TLC556Y DUAL LinCMOS™ TIMERS

SLFS047B – FEBRUARY 1984 – REVISED SEPTEMBER 1997

absolute maximum ratings over operating free-air temperature (unless otherwise noted)

	TLC556C	TLC556I	TLC556M	UNIT
Supply voltage, V_{DD} (see Note 1)	18	18	18	V
Input voltage range, V_I	-0.3 to V_{DD}	-0.3 to V_{DD}	-0.3 to V_{DD}	V
Sink current, discharge or output	150	150	150	mA
Source current, output	15	15	15	mA
Continuous total power dissipation	See Dissipation Rating Table			
Operating free-air temperature range	0 to 70	-40 to 85	-55 to 125	°C
Storage temperature range	-65 to 150	-65 to 150	-65 to 150	°C
Case temperature for 60 seconds	FK package		260	°C
Lead temperature 1,6 mm (1/16 inch) from case for 60 seconds	J package		300	
Lead temperature 1,6 mm (1/16 inch) from case for 10 seconds	D or N package	260	260	

NOTE 1: All voltage values are with respect to network ground terminal.

DISSIPATION RATING TABLE

PACKAGE	$T_A \leq 25^\circ\text{C}$ POWER RATING	DERATING FACTOR ABOVE $T_A = 25^\circ\text{C}$	$T_A = 70^\circ\text{C}$ POWER RATING	$T_A = 85^\circ\text{C}$ POWER RATING	$T_A = 125^\circ\text{C}$ POWER RATING
D	950 mW	7.6 mW/°C	608 mW	494 mW	N/A
FK	1375 mW	11.0 mW/°C	880 mW	715 mW	275 mW
J	1375 mW	11.0 mW/°C	880 mW	715 mW	275 mW
N	1150 mW	9.2 mW/°C	736 mW	598 mW	N/A

recommended operating conditions

		MIN	MAX	UNIT
Supply voltage, V_{DD}		2	15	V
Operating free-air temperature range, T_A	TLC556C	0	70	°C
	TLC556I	-40	85	
	TLC556M	-55	125	

TLC556, TLC556Y DUAL LinCMOS™ TIMERS

SLFS047B – FEBRUARY 1984 – REVISED SEPTEMBER 1997

electrical characteristics at specified free-air temperature, $V_{DD} = 2\text{ V}$ for TLC556C, $V_{DD} = 3\text{ V}$ for TLC556I

PARAMETER	TEST CONDITIONS	T_A †	TLC556C			TLC556I			UNIT
			MIN	TYP	MAX	MIN	TYP	MAX	
V_{IT} Input threshold voltage		25°C	0.95	1.33	1.65	1.6	2	2.4	V
		Full range	0.85		1.75	1.5		2.5	
Threshold current		25°C	10			10			pA
		MAX	75			150			
$V_{(trigger)}$ Trigger voltage		25°C	0.4	0.67	0.95	0.71	1	1.29	V
		Full range	0.3		1.05	0.61		1.39	
$I_{(trigger)}$ Trigger current		25°C	10			10			pA
		MAX	75			150			
$V_{(reset)}$ Reset voltage		25°C	0.4	1.1	1.5	0.4	1.1	1.5	V
		Full range	0.3		1.8	0.3		1.8	
$I_{(reset)}$ Reset current		25°C	10			10			pA
		MAX	75			150			
Control voltage (open circuit) as a percentage of supply voltage		MAX	66.7%			66.7%			
Discharge switch on-state voltage	$I_{OL} = 1\text{ mA}$	25°C	0.04			0.03			V
		Full range	0.25			0.375			
Discharge switch off-state current		25°C	0.1			0.1			nA
		MAX	0.5			120			
V_{OH} High-level output voltage	$I_{OH} = -300\text{ }\mu\text{A}$	25°C	1.5	1.9		1.5	1.9		V
		Full range	1.5			2.5			
V_{OL} Low-level output voltage	$I_{OL} = 1\text{ mA}$	25°C	0.07			0.07			V
		Full range	0.35			0.4			
I_{DD} Supply current	See Note 2	25°C	130			130			μA
		Full range	800			1000			

† Full range is 0°C to 70°C for TLC556C and –40°C to 85°C for TLC556I.

NOTE 2: These values apply for the expected operating configurations in which THRES is connected directly to DISCH or TRIG.

TLC556, TLC556Y DUAL LinCMOS™ TIMERS

SLFS047B – FEBRUARY 1984 – REVISED SEPTEMBER 1997

electrical characteristics at specified free-air temperature, $V_{DD} = 5\text{ V}$

PARAMETER	TEST CONDITIONS	T_A †	TLC556C			TLC556I			TLC556M			UNIT	
			MIN	TYP	MAX	MIN	TYP	MAX	MIN	TYP	MAX		
V_{IT}	Input threshold voltage	25°C	2.8	3.3	3.8	2.8	3.3	3.8	2.8	3.3	3.8	V	
		Full range	2.7		3.9	2.7		3.9	2.7		3.9		
Threshold current		25°C		10			10			10	pA		
		MAX		75			150			5000			
$V_{(trigger)}$	Trigger voltage	25°C	1.36	1.66	1.96	1.36	1.66	1.96	1.36	1.66	1.96	V	
		Full range	1.26		2.06	1.26		2.06	1.26		2.06		
$I_{(trigger)}$	Trigger current	25°C		10			10			10	pA		
		MAX		75			150			5000			
$V_{(reset)}$	Reset voltage	25°C	0.4	1.1	1.5	0.4	1.1	1.5	0.4	1.1	1.5	V	
		Full range	0.3		1.8	0.3		1.8	0.3		1.8		
$I_{(reset)}$	Reset current	25°C		10			10			10	pA		
		MAX		75			150			5000			
Control voltage (open circuit) as a percentage of supply voltage		MAX	66.7%			66.7%			66.7%				
Discharge switch on-state voltage	$I_{OL} = 10\text{ mA}$	25°C		0.15	0.5		0.15	0.5		0.15	0.5	V	
		Full range			0.6			0.6			0.6		
Discharge switch off-state current		25°C		0.1			0.1			0.1	nA		
		MAX		0.5			2			120			
V_{OH}	High-level output voltage	$I_{OH} = -1\text{ mA}$	25°C	4.1	4.8		4.1	4.8		4.1	4.8	V	
		Full range	4.1			4.1			4.1				
V_{OL}	Low-level output voltage	$I_{OL} = 8\text{ mA}$	25°C		0.21	0.4		0.21	0.4		0.21	0.4	V
			Full range			0.5			0.5			0.6	
		$I_{OL} = 5\text{ mA}$	25°C		0.13	0.3		0.13	0.3		0.13	0.3	
			Full range			0.4			0.4			0.45	
		$I_{OL} = 3.2\text{ mA}$	25°C		0.08	0.3		0.08	0.3		0.08	0.3	
			Full range			0.35			0.35			0.4	
I_{DD}	Supply current	See Note 2	25°C		340	700		340	700		340	700	μA
			Full range			1000			1200			1400	

† Full range is 0°C to 70°C for TLC556C, -40°C to 85°C for TLC556I, and -55°C to 125°C for TLC556M.

NOTE 2: These values apply for the expected operating configurations in which THRES is connected directly to DISCH or to TRIG.

TLC556, TLC556Y DUAL LinCMOS™ TIMERS

SLFS047B – FEBRUARY 1984 – REVISED SEPTEMBER 1997

electrical characteristics at specified free-air temperature, $V_{DD} = 15\text{ V}$

PARAMETER		TEST CONDITIONS	T_A †	TLC556C			TLC556I			TLC556M			UNIT
				MIN	TYP	MAX	MIN	TYP	MAX	MIN	TYP	MAX	
V_{IT}	Input threshold voltage		25°C	9.45	10	10.55	9.45	10	10.55	9.45	10	10.55	V
			Full range	9.35		10.65	9.35		10.65	9.35		10.65	
	Threshold current		25°C	10			10			10			pA
			MAX	75			150			5000			
$V_{(trigger)}$	Trigger voltage		25°C	4.65	5	5.35	4.65	5	5.35	4.65	5	5.35	V
			Full range	4.55		5.45	4.55		5.45	4.55		5.45	
$I_{(trigger)}$	Trigger current		25°C	10			10			10			pA
			MAX	75			150			5000			
$V_{(reset)}$	Reset voltage		25°C	0.4	1.1	1.5	0.4	1.1	1.5	0.4	1.1	1.5	V
			Full range	0.3		1.8	0.3		1.8	0.3		1.8	
$I_{(reset)}$	Reset current		25°C	10			10			10			pA
			MAX	75			150			5000			
	Control voltage (open circuit) as a percentage of supply voltage		MAX	66.7%			66.7%			66.7%			
	Discharge switch on-state voltage	$I_{OL} = 100\text{ mA}$	25°C	0.8			0.8			0.8			V
			Full range	1.7			1.7			1.7			
	Discharge switch off-state current		25°C	0.1			0.1			0.1			nA
			MAX	0.5			2			120			
V_{OH}	High-level output voltage	$I_{OH} = -10\text{ mA}$	25°C	12.5	14.2		12.5	14.2		12.5	14.2		V
			Full range	12.5			12.5			12.5			
		$I_{OH} = -5\text{ mA}$	25°C	13.5	14.6		13.5	14.6		13.5	14.6		
			Full range	13.5			13.5			13.5			
		$I_{OH} = -1\text{ mA}$	25°C	14.2	14.9		14.2	14.9		14.2	14.9		
			Full range	14.2			14.2			14.2			
V_{OL}	Low-level output voltage	$I_{OL} = 100\text{ mA}$	25°C	1.28			1.28			1.28			V
			Full range	3.2			3.2			3.2			
		$I_{OL} = 50\text{ mA}$	25°C	0.63			0.63			0.63			
			Full range	1			1			1			
		$I_{OL} = 10\text{ mA}$	25°C	0.12			0.12			0.12			
			Full range	0.3			0.3			0.3			
	Supply current	See Note 2	25°C	0.72			0.72			0.72			mA
			Full range	1.2			1.2			1.2			

† Full range is 0°C to 70°C for TLC556C, -40°C to 85°C for TLC556I, and -55°C to 125°C for TLC556M.

NOTE 2: These values apply for the expected operating configurations in which THRES is connected directly to DISCH or TRIG.

TLC556, TLC556Y DUAL LinCMOS™ TIMERS

SLFS047B – FEBRUARY 1984 – REVISED SEPTEMBER 1997

electrical characteristics, $V_{DD} = 5\text{ V}$, $T_A = 25^\circ\text{C}$

PARAMETER		TEST CONDITIONS	MIN	TYP	MAX	UNIT
V_{IT}	Input threshold voltage		2.8	3.3	3.8	V
	Threshold current			10		pA
$V_{(trigger)}$	Trigger voltage		1.36	1.66	1.96	V
$I_{(trigger)}$	Trigger current			10		pA
$V_{(reset)}$	Reset voltage		0.4	1.1	1.5	V
$I_{(reset)}$	Reset current			10		pA
	Discharge switch on-state voltage	$I_{OL} = 10\text{ mA}$		0.15	0.5	V
	Discharge switch off-state current			0.1		nA
V_{OH}	High-level output voltage	$I_{OH} = -1\text{ mA}$	4.1	4.8		V
V_{OL}	Low-level output voltage	$I_{OL} = 8\text{ mA}$		0.21	0.4	V
		$I_{OL} = 5\text{ mA}$		0.13	0.3	
		$I_{OL} = 2.1\text{ mA}$		0.08	0.3	
I_{DD}	Supply current	See Note 2		3.40	700	μA

NOTE 2: These values apply for the expected operating configurations in which THRES is connected directly to DISCH or TRIG.

operating characteristics, $V_{DD} = 5\text{ V}$, $T_A = 25^\circ\text{C}$ (unless otherwise noted)

PARAMETER		TEST CONDITIONS	MIN	TYP	MAX	UNIT
	Initial error of timing interval †	$V_{DD} = 5\text{ V to }15\text{ V}$, $R_A = R_B = 1\text{ k}\Omega\text{ to }100\text{ k}\Omega$		1%	3%	
	Supply voltage sensitivity of timing interval	$C_T = 0.1\ \mu\text{F}$, See Note 3		0.1	0.5	%/V
t_r	Output pulse rise time	$R_L = 10\text{ M}\Omega$, $C_L = 10\text{ pF}$		20	75	ns
t_f	Output pulse fall time			15	60	
f_{max}	Maximum frequency in astable mode	$R_A = 470\ \Omega$, $C_T = 200\text{ pF}$, $R_B = 200\ \Omega$, See Note 3	1.2	2.1		MHz

† Timing interval error is defined as the difference between the measured value and the average value of a random sample from each process run.

NOTE 3: R_A , R_B , and C_T are as defined in Figure 3.

TYPICAL CHARACTERISTICS

DISCHARGE SWITCH ON-STATE RESISTANCE
vs
FREE-AIR TEMPERATURE

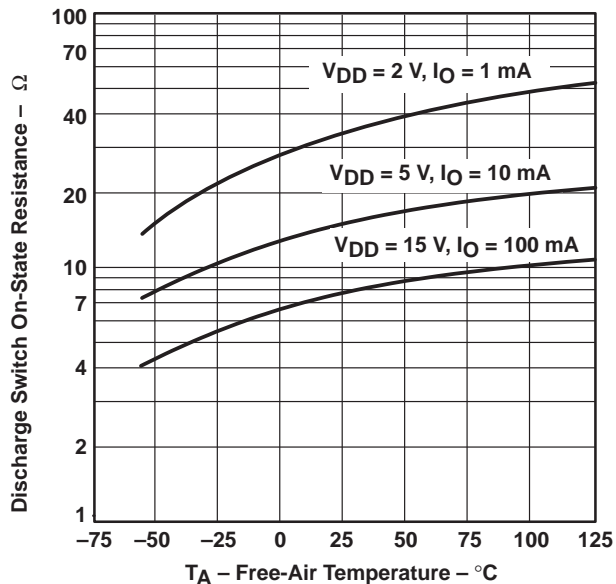
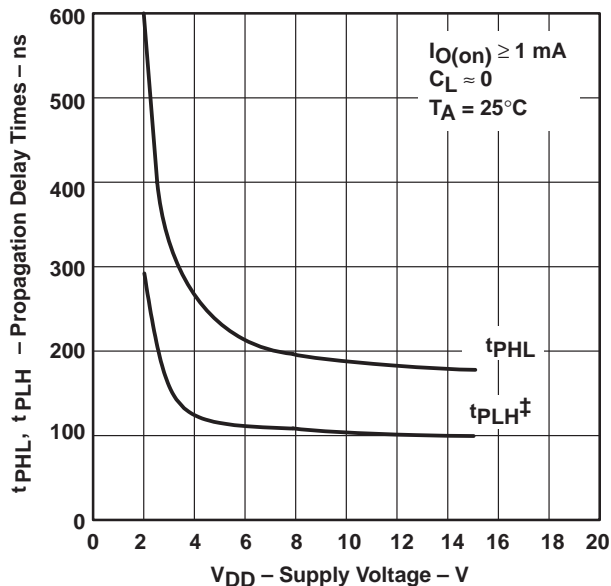

Figure 1

PROPAGATION DELAY TIMES (TO DISCHARGE
OUTPUT FROM TRIGGER AND THRESHOLD
SHORTED TOGETHER)
vs
SUPPLY VOLTAGE



‡ The effects of the load resistance on these values must be taken into account separately.

Figure 2

TLC556, TLC556Y DUAL LinCMOS™ TIMERS

SLFS047B – FEBRUARY 1984 – REVISED SEPTEMBER 1997

APPLICATION INFORMATION

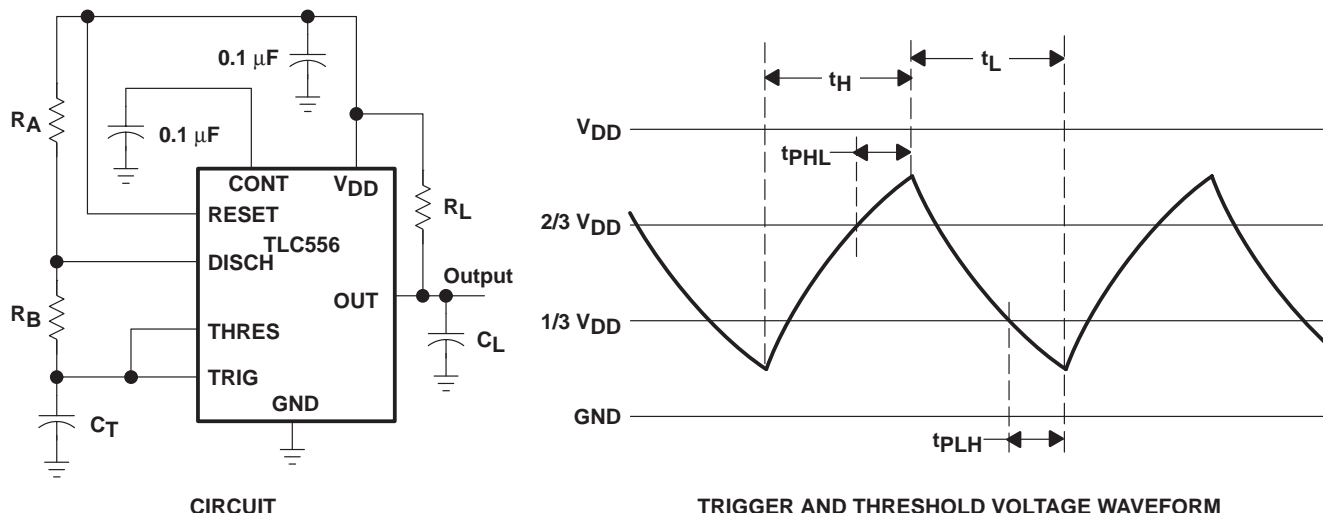

Figure 3. Astable Operation

Connecting the trigger input to the threshold input, as shown in Figure 3, causes the timer to run as a multivibrator. The capacitor C_T charges through R_A and R_B to the threshold voltage level (approximately $0.67 V_{DD}$) and then discharges through R_B only to the value of the trigger voltage level (approximately $0.33 V_{DD}$). The output is high during the charging cycle (t_H) and low during the discharge cycle (t_L). The duty cycle is controlled by the values of R_A , and R_B , and C_T , as shown in the equations below.

$$t_H \approx C_T (R_A + R_B) \ln 2 \quad (\ln 2 = 0.693)$$

$$t_L \approx C_T R_B \ln 2$$

$$\text{Period} = t_H + t_L \approx C_T (R_A + 2R_B) \ln 2$$

$$\text{Output driver duty cycle} = \frac{t_L}{t_H + t_L} \approx 1 - \frac{R_B}{R_A + 2R_B}$$

$$\text{Output waveform duty cycle} = \frac{t_H}{t_H + t_L} \approx \frac{R_B}{R_A + 2R_B}$$

The 0.1- μF capacitor at CONT in Figure 3 decreases the period by about 10%.

The formulas shown above do not allow for any propagation delay from the trigger and threshold inputs to the discharge output. These delay times add directly to the period and create differences between calculated and actual values that increase with frequency. In addition, the discharge output resistance r_{on} adds to R_B to provide another source of error in the calculation when R_B is very low or r_{on} is very high.

The equations below provide better agreement with measured values.

$$t_H = C_T (R_A + R_B) \ln \left[3 - \exp \left(\frac{-t_{PLH}}{C_T (R_B + r_{on})} \right) \right] + t_{PHL}$$

$$t_L = C_T (R_B + r_{on}) \ln \left[3 - \exp \left(\frac{-t_{PHL}}{C_T (R_A + R_B)} \right) \right] + t_{PLH}$$

APPLICATION INFORMATION

The preceding equations and those given earlier are similar in that a time constant is multiplied by the logarithm of a number or function. The limit values of the logarithmic terms must be between $\ln 2$ at low frequencies and $\ln 3$ at extremely high frequencies. For a duty cycle close to 50%, an appropriate constant for the logarithmic terms can be substituted with good results. Duty cycles less than 50% $\frac{t_H}{t_H + t_L}$ will require that $\frac{t_H}{t_L} < 1$ and possibly $R_A \leq r_{on}$. These conditions can be difficult to obtain.

In monostable applications, the trip point of the trigger input can be set by a voltage applied to CONT. An input voltage between 10% and 80% of the supply voltage from a resistor divider with at least 500- μ A bias provides good results.

TLC556, TLC556Y DUAL LinCMOS™ TIMERS

SLFS047B – FEBRUARY 1984 – REVISED SEPTEMBER 1997

MECHANICAL INFORMATION

D (R-PDSO-G**)

PLASTIC SMALL-OUTLINE PACKAGE

14 PIN SHOWN

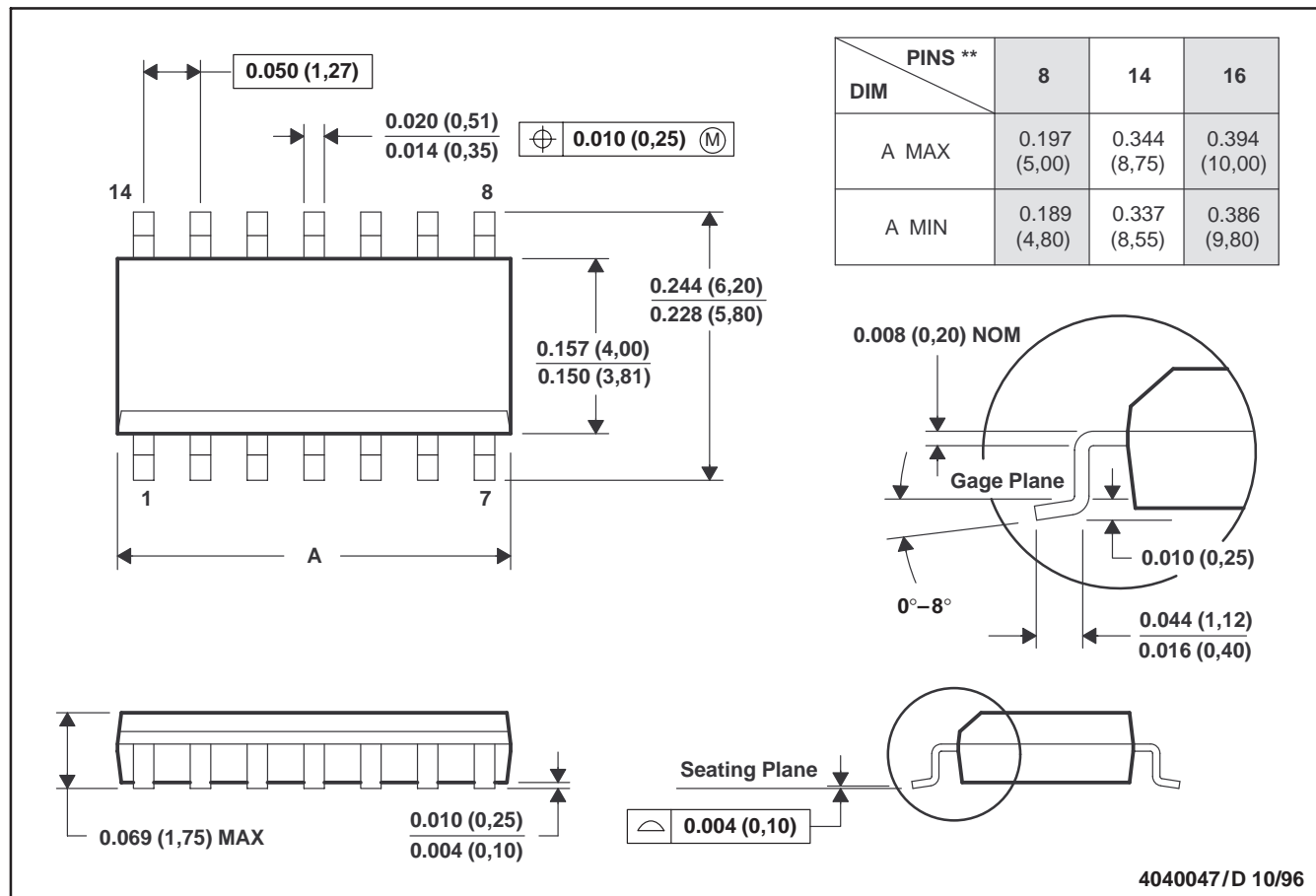

- NOTES:
- A. All linear dimensions are in inches (millimeters).
 - B. This drawing is subject to change without notice.
 - C. Body dimensions do not include mold flash or protrusion, not to exceed 0.006 (0,15).
 - D. Falls within JEDEC MS-012

TLC556, TLC556Y DUAL LinCMOS™ TIMERS

SLFS047B – FEBRUARY 1984 – REVISED SEPTEMBER 1997

MECHANICAL INFORMATION

FK (S-CQCC-N**)

LEADLESS CERAMIC CHIP CARRIER

28 TERMINAL SHOWN

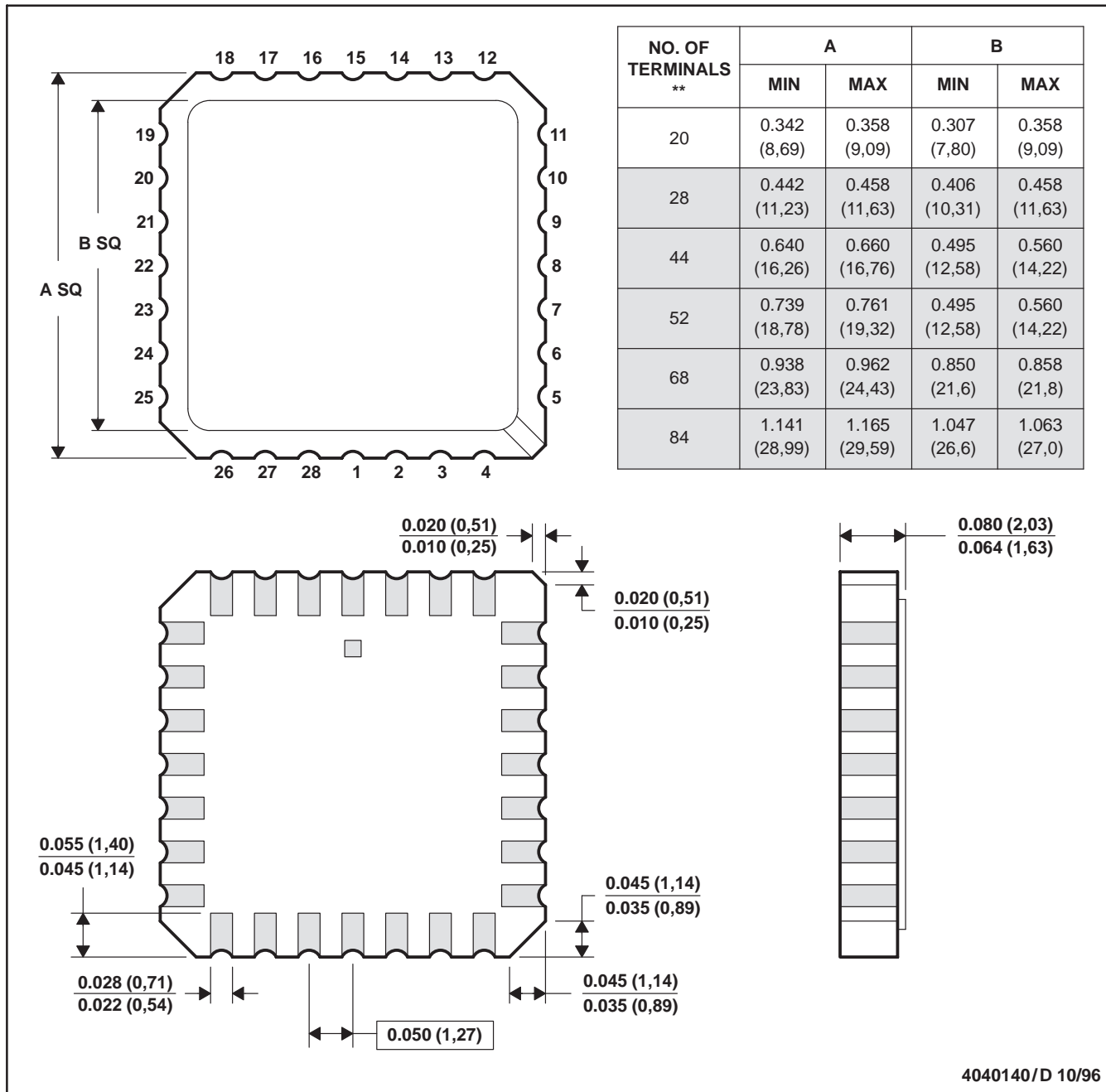

- NOTES:
- All linear dimensions are in inches (millimeters).
 - This drawing is subject to change without notice.
 - This package can be hermetically sealed with a metal lid.
 - The terminals are gold plated.
 - Falls within JEDEC MS-004

TLC556, TLC556Y DUAL LinCMOS™ TIMERS

SLFS047B – FEBRUARY 1984 – REVISED SEPTEMBER 1997

MECHANICAL INFORMATION

J (R-GDIP-T**)

CERAMIC DUAL-IN-LINE PACKAGE

14 PIN SHOWN

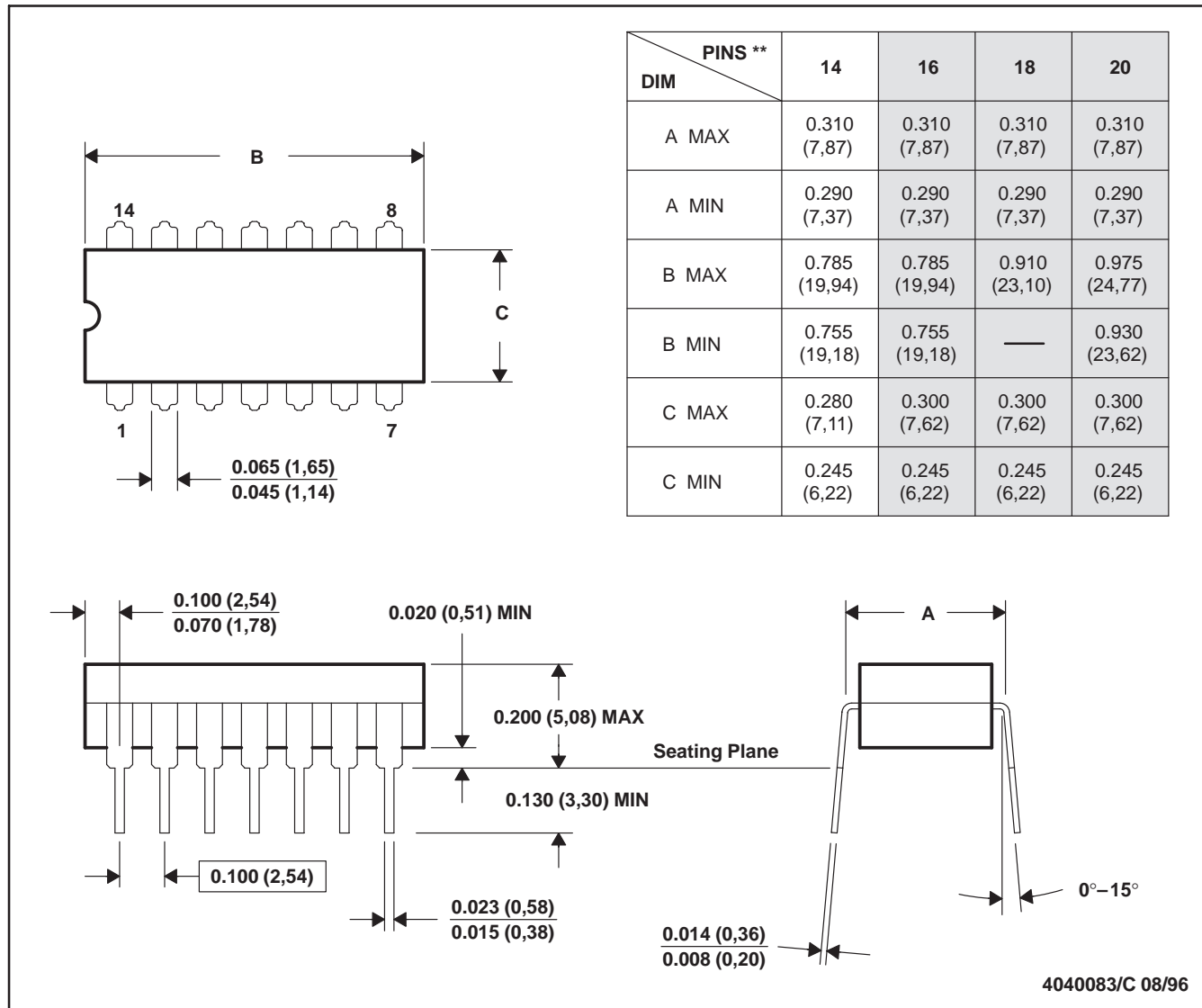

- NOTES:
- A. All linear dimensions are in inches (millimeters).
 - B. This drawing is subject to change without notice.
 - C. This package can be hermetically sealed with a ceramic lid using glass frit.
 - D. Index point is provided on cap for terminal identification only on press ceramic glass frit seal only.
 - E. Falls within MIL-STD-1835 GDIP1-T14, GDIP1-T16, GDIP1-T18, and GDIP1-T20

TLC556, TLC556Y DUAL LinCMOS™ TIMERS

SLFS047B – FEBRUARY 1984 – REVISED SEPTEMBER 1997

MECHANICAL INFORMATION

N (R-PDIP-T**)

PLASTIC DUAL-IN-LINE PACKAGE

16 PIN SHOWN

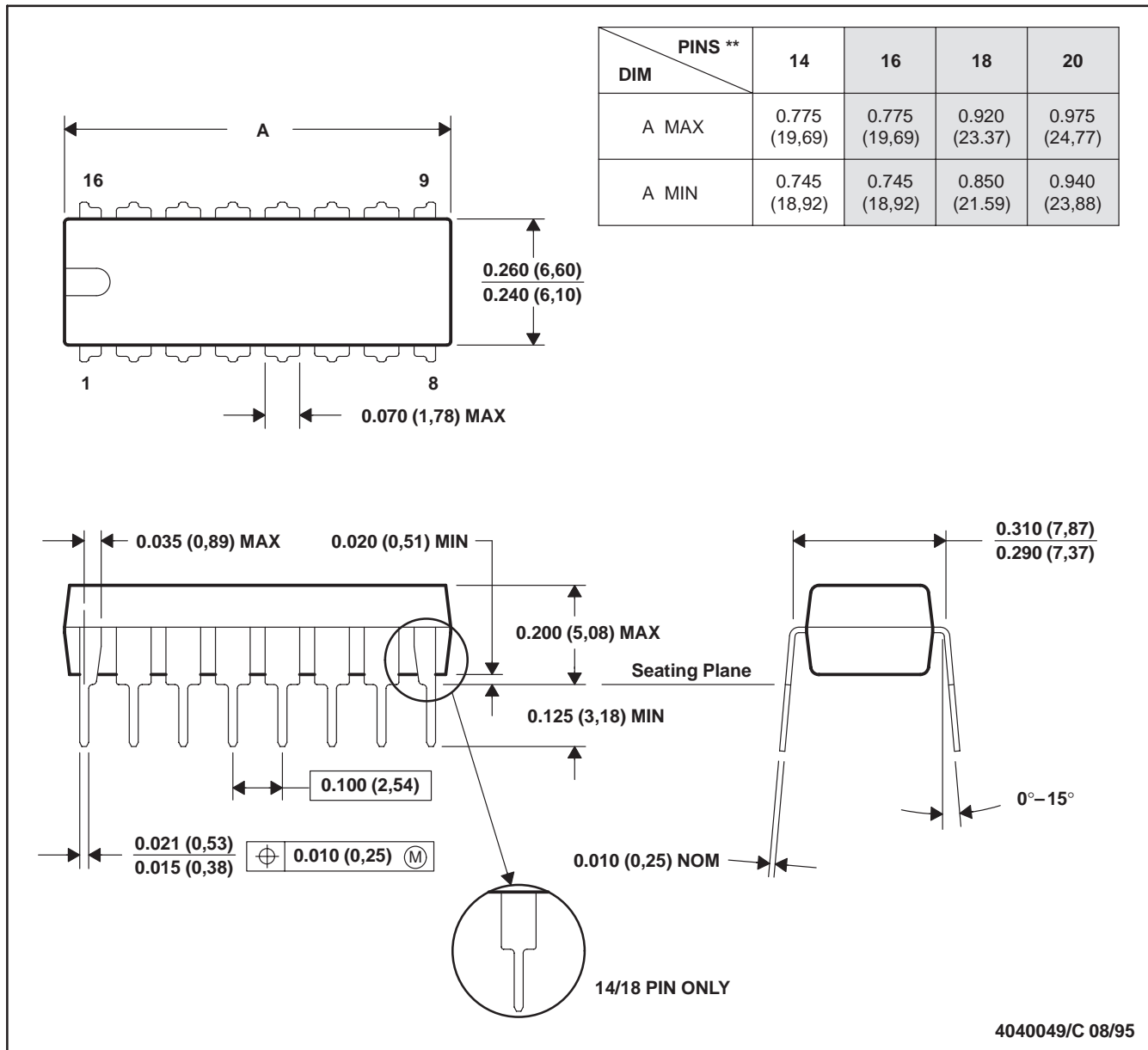

- NOTES: A. All linear dimensions are in inches (millimeters).
 B. This drawing is subject to change without notice.
 C. Falls within JEDEC MS-001 (20 pin package is shorter than MS-001.)

PACKAGING INFORMATION

Orderable Device	Status ⁽¹⁾	Package Type	Package Drawing	Pins	Package Qty	Eco Plan ⁽²⁾	Lead/Ball Finish	MSL Peak Temp ⁽³⁾
5962-89503022A	ACTIVE	LCCC	FK	20	1	None	POST-PLATE	Level-NC-NC-NC
5962-8950302CA	ACTIVE	CDIP	J	14	1	None	A42 SNPB	Level-NC-NC-NC
TLC556CD	ACTIVE	SOIC	D	14	50	Pb-Free (RoHS)	CU NIPDAU	Level-2-260C-1YEAR/ Level-1-220C-UNLIM
TLC556CDG4	ACTIVE	SOIC	D	14	50	Pb-Free (RoHS)	CU NIPDAU	Level-2-260C-1YEAR/ Level-1-220C-UNLIM
TLC556CDR	ACTIVE	SOIC	D	14	2500	Pb-Free (RoHS)	CU NIPDAU	Level-2-260C-1YEAR/ Level-1-220C-UNLIM
TLC556CDRG4	ACTIVE	SOIC	D	14	2500	Pb-Free (RoHS)	CU NIPDAU	Level-2-260C-1YEAR/ Level-1-220C-UNLIM
TLC556CN	ACTIVE	PDIP	N	14	25	Pb-Free (RoHS)	CU NIPD	Level-NC-NC-NC
TLC556CNE4	ACTIVE	PDIP	N	14	25	None	Call TI	Call TI
TLC556ID	ACTIVE	SOIC	D	14	50	Pb-Free (RoHS)	CU NIPDAU	Level-2-260C-1YEAR/ Level-1-220C-UNLIM
TLC556IDR	ACTIVE	SOIC	D	14	2500	Pb-Free (RoHS)	CU NIPDAU	Level-2-260C-1YEAR/ Level-1-220C-UNLIM
TLC556IN	ACTIVE	PDIP	N	14	25	Pb-Free (RoHS)	CU NIPD	Level-NC-NC-NC
TLC556INE4	ACTIVE	PDIP	N	14	25	None	Call TI	Call TI
TLC556MD	ACTIVE	SOIC	D	14	50	None	CU NIPDAU	Level-1-220C-UNLIM
TLC556MDR	ACTIVE	SOIC	D	14	1	None	CU NIPDAU	Level-1-220C-UNLIM
TLC556MFKB	ACTIVE	LCCC	FK	20	1	None	POST-PLATE	Level-NC-NC-NC
TLC556MJ	ACTIVE	CDIP	J	14	1	None	A42 SNPB	Level-NC-NC-NC
TLC556MJB	ACTIVE	CDIP	J	14	1	None	A42 SNPB	Level-NC-NC-NC
TLC556MN	OBSOLETE	PDIP	N	14		None	Call TI	Call TI

⁽¹⁾ The marketing status values are defined as follows:

ACTIVE: Product device recommended for new designs.

LIFEBUY: TI has announced that the device will be discontinued, and a lifetime-buy period is in effect.

NRND: Not recommended for new designs. Device is in production to support existing customers, but TI does not recommend using this part in a new design.

PREVIEW: Device has been announced but is not in production. Samples may or may not be available.

OBSOLETE: TI has discontinued the production of the device.

⁽²⁾ Eco Plan - May not be currently available - please check <http://www.ti.com/productcontent> for the latest availability information and additional product content details.

None: Not yet available Lead (Pb-Free).

Pb-Free (RoHS): TI's terms "Lead-Free" or "Pb-Free" mean semiconductor products that are compatible with the current RoHS requirements for all 6 substances, including the requirement that lead not exceed 0.1% by weight in homogeneous materials. Where designed to be soldered at high temperatures, TI Pb-Free products are suitable for use in specified lead-free processes.

Green (RoHS & no Sb/Br): TI defines "Green" to mean "Pb-Free" and in addition, uses package materials that do not contain halogens, including bromine (Br) or antimony (Sb) above 0.1% of total product weight.

⁽³⁾ MSL, Peak Temp. -- The Moisture Sensitivity Level rating according to the JEDEC industry standard classifications, and peak solder temperature.

Important Information and Disclaimer: The information provided on this page represents TI's knowledge and belief as of the date that it is provided. TI bases its knowledge and belief on information provided by third parties, and makes no representation or warranty as to the accuracy of such information. Efforts are underway to better integrate information from third parties. TI has taken and continues to take reasonable steps to provide representative and accurate information but may not have conducted destructive testing or chemical analysis on

incoming materials and chemicals. TI and TI suppliers consider certain information to be proprietary, and thus CAS numbers and other limited information may not be available for release.

In no event shall TI's liability arising out of such information exceed the total purchase price of the TI part(s) at issue in this document sold by TI to Customer on an annual basis.

IMPORTANT NOTICE

Texas Instruments Incorporated and its subsidiaries (TI) reserve the right to make corrections, modifications, enhancements, improvements, and other changes to its products and services at any time and to discontinue any product or service without notice. Customers should obtain the latest relevant information before placing orders and should verify that such information is current and complete. All products are sold subject to TI's terms and conditions of sale supplied at the time of order acknowledgment.

TI warrants performance of its hardware products to the specifications applicable at the time of sale in accordance with TI's standard warranty. Testing and other quality control techniques are used to the extent TI deems necessary to support this warranty. Except where mandated by government requirements, testing of all parameters of each product is not necessarily performed.

TI assumes no liability for applications assistance or customer product design. Customers are responsible for their products and applications using TI components. To minimize the risks associated with customer products and applications, customers should provide adequate design and operating safeguards.

TI does not warrant or represent that any license, either express or implied, is granted under any TI patent right, copyright, mask work right, or other TI intellectual property right relating to any combination, machine, or process in which TI products or services are used. Information published by TI regarding third-party products or services does not constitute a license from TI to use such products or services or a warranty or endorsement thereof. Use of such information may require a license from a third party under the patents or other intellectual property of the third party, or a license from TI under the patents or other intellectual property of TI.

Reproduction of information in TI data books or data sheets is permissible only if reproduction is without alteration and is accompanied by all associated warranties, conditions, limitations, and notices. Reproduction of this information with alteration is an unfair and deceptive business practice. TI is not responsible or liable for such altered documentation.

Resale of TI products or services with statements different from or beyond the parameters stated by TI for that product or service voids all express and any implied warranties for the associated TI product or service and is an unfair and deceptive business practice. TI is not responsible or liable for any such statements.

Following are URLs where you can obtain information on other Texas Instruments products and application solutions:

Products		Applications	
Amplifiers	amplifier.ti.com	Audio	www.ti.com/audio
Data Converters	dataconverter.ti.com	Automotive	www.ti.com/automotive
DSP	dsp.ti.com	Broadband	www.ti.com/broadband
Interface	interface.ti.com	Digital Control	www.ti.com/digitalcontrol
Logic	logic.ti.com	Military	www.ti.com/military
Power Mgmt	power.ti.com	Optical Networking	www.ti.com/opticalnetwork
Microcontrollers	microcontroller.ti.com	Security	www.ti.com/security
		Telephony	www.ti.com/telephony
		Video & Imaging	www.ti.com/video
		Wireless	www.ti.com/wireless

Mailing Address: Texas Instruments
Post Office Box 655303 Dallas, Texas 75265