

- **Drive Capability:**
 - Segment . . . 30 mA × 16 Bits
 - Common . . . 640 mA
- **Constant Current Output . . . 3 mA to 30 mA (Current Value Setting for All Channels Using External Resistor)**
- **Constant Current Accuracy ±6% (Maximum Error Between Bits)**
- **Data Input: Clock Synchronized Serial Input**
- **LED Type Applied Cathode Common**
- **Logic Power Supply Voltage 4.5 V to 5.5 V**
- **LED Power Supply Voltage 4.5 V to 5.5 V**
- **Operating Frequency . . . 10 MHz**
- **Operating Free-Air Temperature Range –20°C to 85°C**
- **48-Pin SSOL Package**

description

The TLC5920 is an LED driver incorporating a 16-channel shift register, data latch, and constant current circuitry with current value control and 8-channel common driver into a single chip. The constant output current is capable of 30 mA for 16 bits simultaneously, and the current value can be set by one external register. This device also includes a 16-bit segment driver and 8-bit common driver; therefore, the monochrome LED array with 16 × 8 dots can be driven by only one TLC5920, and a two-color LED array with 16 x 16 dots can be driven by two TLC5920s.

DL PACKAGE (TOP VIEW)

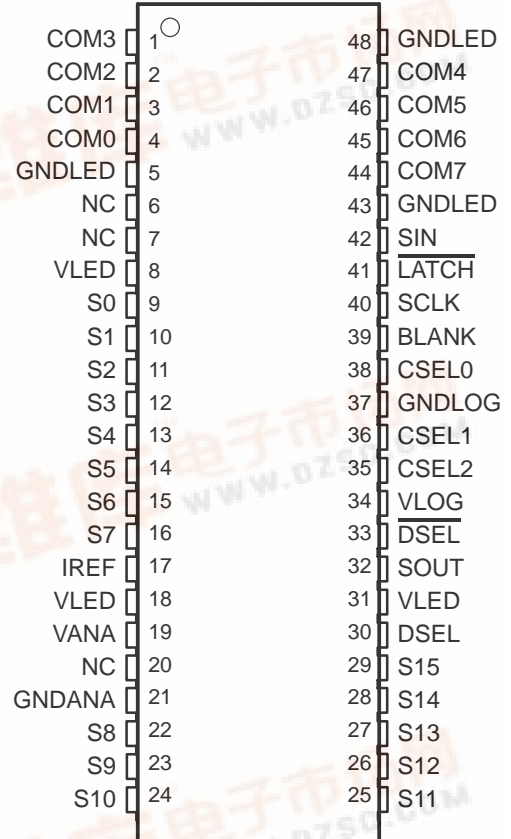

Please be aware that an important notice concerning availability, standard warranty, and use in critical applications of Texas Instruments semiconductor products and disclaimers thereto appears at the end of this data sheet.

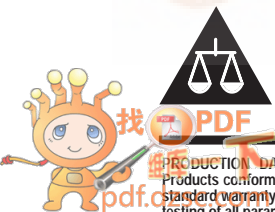

PRODUCTION DATA information is current as of publication date. Products conform to specifications per the terms of Texas Instruments standard warranty. Production processing does not necessarily include testing of all parameters.



TLC5920 16x8 BIT LED DRIVER/CONTROLLER

SLAS264 – MARCH 2000

functional block diagram

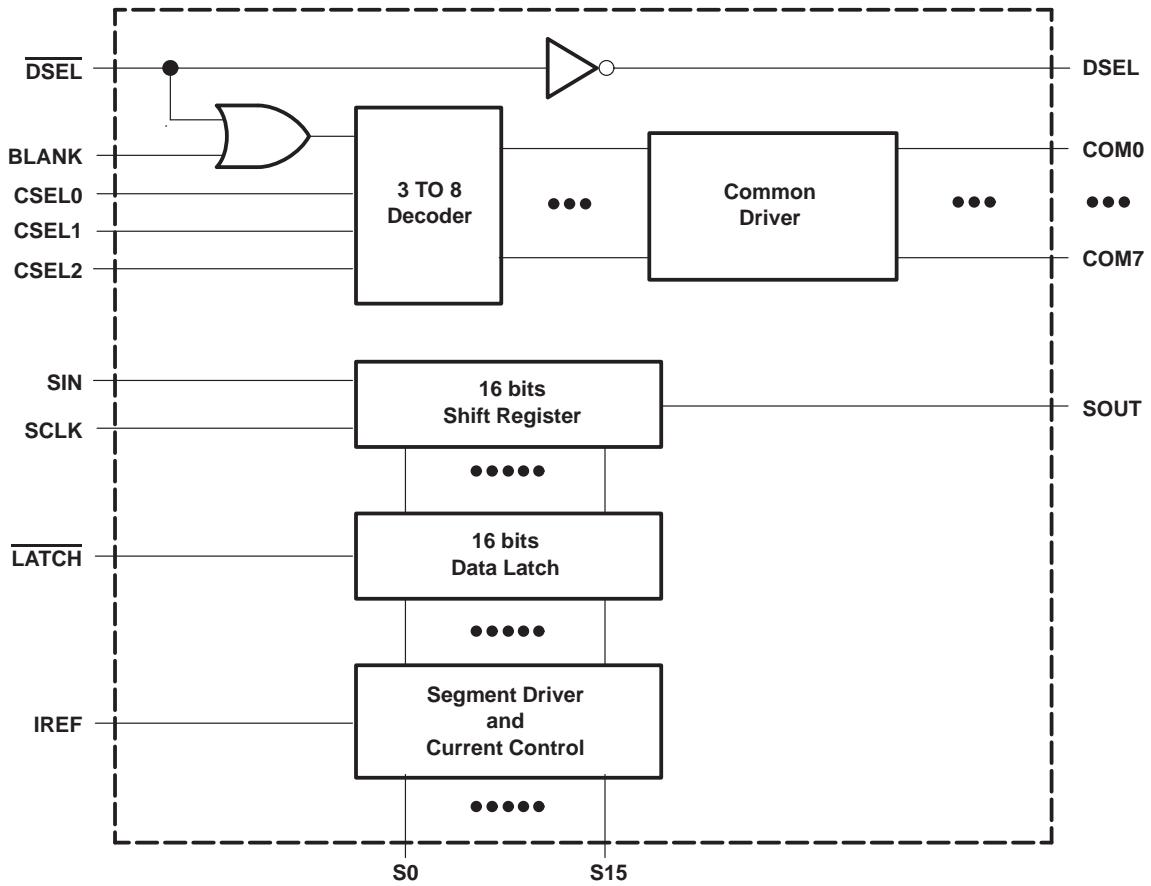

TLC5920
16x8 BIT LED DRIVER/CONTROLLER

SLAS264 – MARCH 2000

Terminal Functions

TERMINAL NAME	NO.	I/O	DESCRIPTION																																				
BLANK	39	I	Blank(light off). By turning all the output for the common driver off, the LED is turned off. When BLANK is high, the LED is turned off.																																				
COM0 – COM7	4, 3, 2, 1, 47, 46, 45, 44	O	LED common driver output																																				
CSEL0 – 2	38, 36, 35	I	Common driver select. One terminal out of COM0 through COM7 is selected. <table style="margin-left: auto; margin-right: auto; border-collapse: collapse;"> <tr> <td style="padding: 0 10px;">2</td> <td style="padding: 0 10px;">1</td> <td style="padding: 0 10px;">0</td> <td style="padding: 0 10px;">Common Driver</td> </tr> <tr> <td>L</td> <td>L</td> <td>L</td> <td style="text-align: center;">0</td> </tr> <tr> <td>L</td> <td>L</td> <td>H</td> <td style="text-align: center;">1</td> </tr> <tr> <td>L</td> <td>H</td> <td>L</td> <td style="text-align: center;">2</td> </tr> <tr> <td>L</td> <td>H</td> <td>H</td> <td style="text-align: center;">3</td> </tr> <tr> <td>H</td> <td>L</td> <td>L</td> <td style="text-align: center;">4</td> </tr> <tr> <td>H</td> <td>L</td> <td>H</td> <td style="text-align: center;">5</td> </tr> <tr> <td>H</td> <td>H</td> <td>L</td> <td style="text-align: center;">6</td> </tr> <tr> <td>H</td> <td>H</td> <td>H</td> <td style="text-align: center;">7</td> </tr> </table>	2	1	0	Common Driver	L	L	L	0	L	L	H	1	L	H	L	2	L	H	H	3	H	L	L	4	H	L	H	5	H	H	L	6	H	H	H	7
2	1	0	Common Driver																																				
L	L	L	0																																				
L	L	H	1																																				
L	H	L	2																																				
L	H	H	3																																				
H	L	L	4																																				
H	L	H	5																																				
H	H	L	6																																				
H	H	H	7																																				
$\overline{\text{DSEL}}$	33	I	Display select. When $\overline{\text{DSEL}}$ is high, the LED is turned off. Note that, when BLANK is high, the LED is turned off with no regard to the $\overline{\text{DSEL}}$ input.																																				
DSEL	30	O	Display select output. The inverted data of $\overline{\text{DSEL}}$ is clocked out.																																				
GNDANA	21		Analog ground																																				
GNDLED	5, 43, 48		LED driver ground																																				
GNDLOG	37		Logic ground																																				
IREF	17	I	Constant current control setting. The LED current is set to the desired value by connecting an external resistor between IREF and GND.																																				
$\overline{\text{LATCH}}$	41	I	Latch. When $\overline{\text{LATCH}}$ is high, data on the shift register goes through latch. When $\overline{\text{LATCH}}$ is low, data is latched.																																				
SIN	42	I	Serial input for display																																				
SOUT	32	O	Serial output for display																																				
SCLK	40	I	Synchronous clock input for serial data transfer. The input data of SIN is synchronized to the rising edge of SCLK, and transferred to SOUT.																																				
S0 – S15	9, 10, 11, 12, 13, 14, 15, 16, 22, 23, 24, 25, 26, 27, 28, 29	O	LED segment driver output																																				
VANA	19		Analog power supply voltage																																				
VLOG	34		Logic power supply voltage																																				
VLED	8, 18, 31		LED driver power supply voltage																																				

TLC5920

16x8 BIT LED DRIVER/CONTROLLER

SLAS264 – MARCH 2000

absolute maximum ratings† (see Note 1)

Logic supply voltage, $V_{(LOG)}$	– 0.3 V to 7 V
LED supply voltage, $V_{(LED)}$	– 0.3 V to 7 V
Analog supply voltage, $V_{(ANA)}$	– 0.3 V to 7 V
Output current, $I_{OH(S)}$	– 32 mA
Output current, $I_{OL(C)}$	650 mA
Input voltage range, V_I	– 0.3 V to $V_{(LOG)} + 0.3$ V
Output voltage range, V_O	– 0.3 V to $V_{(LOG)} + 0.3$ V
Continuous total power dissipation	1500 mW
Thermal resistance	83°C/W
Operating free-air temperature range (see Note 2), T_A	– 20 to 85°C
Storage temperature range, T_{stg}	– 40°C to 125°C

† Stresses beyond those listed under “absolute maximum ratings” may cause permanent damage to the device. These are stress ratings only, and functional operation of the device at these or any other conditions beyond those indicated under “recommended operating conditions” is not implied. Exposure to absolute-maximum-rated conditions for extended periods may affect device reliability.

- NOTES: 1. All voltage values are with respect to GND terminal.
 2. $T_J \leq 150^\circ\text{C}$ (refer to appendix thermal condition).

recommended operating conditions

dc characteristics (see Note 3)

PARAMETER	TEST CONDITIONS	MIN	NOM	MAX	UNIT
Logic supply voltage, $V_{(LOG)}$		4.5	5	5.5	V
LED supply voltage, $V_{(LED)}$		4.5	5	5.5	V
Analog power supply, $V_{(ANA)}$		4.5	5	5.5	V
Voltage between GND and $V_{(DEF)}$, $G_{(DEF)}$	$G_{(DEF)} = GND_{(LOG)} - GND_{(LED)}$	– 0.3	0	0.3	V
High-level input voltage, V_{IH}		2.0		$V_{(LOG)}$	V
Low-level input voltage, V_{IL}		$GND_{(LOG)}$		0.8	V
High-level output current, I_{OH}	$V_{(LOG)} = 4.5\text{V}$, SOUT, DSEL			– 1	mA
High-level output current, $I_{OH(S)}$	S0 to S15			– 30	
Low-level output current, I_{OL}	$V_{(LOG)} = 4.5\text{V}$, SOUT, DSEL			1.6	mA
Low-level output current, $I_{OL(C)}$	DUTY = 1/16, COM0 to COM7			640	
Operating free-air temperature range, T_A (see Note 2)		– 20		85	°C

- NOTES: 2. $T_J \leq 150^\circ\text{C}$ (refer to appendix thermal condition).
 3. V_{ANA} must be same as V_{LED} .

ac characteristics ($T_A = -20^\circ\text{C}$ to 85°C)

PARAMETER	TEST CONDITIONS	MIN	NOM	MAX	UNIT
$f_{(SCLK)}$ Shift clock frequency				10	MHz
$t_{w(H)}/t_{w(L)}$ SCLK pulse duration (high- or low-level)		40			ns
t_r/t_f Rise/fall time				100	ns
t_{su} Setup time	SIN – SCLK	10			ns
	SCLK – LATCH	10			
t_h Hold time	LATCH – SCLK	10			ns
	SIN – SCLK	10			

TLC5920
16x8 BIT LED DRIVER/CONTROLLER

SLAS264 – MARCH 2000

electrical characteristics (unless otherwise noted),

MIN/MAX: $V_{(LOG)} = V_{(ANA)} = V_{(LED)} = 4.5\text{ V to }5.5\text{ V}$, $T_A = -20^\circ\text{C to }85^\circ\text{C}$

TYP: $V_{(LOG)} = V_{(ANA)} = V_{(LED)} = 5\text{ V}$, $T_A = 25^\circ\text{C}$

PARAMETER		TEST CONDITIONS	MIN	TYP	MAX	UNIT
V_{OH}	High-level output voltage	$I_{OH} = -1\text{ mA}$, SOUT, DSEL	3.6			V
V_{OL}	Low-level output voltage	$I_{OL} = 1.6\text{ mA}$, SOUT, DSEL			0.6	V
		$I_{OL} = 640\text{ mA}$, COM0 to COM7		0.6	0.9	
I_I	Input current	$V_I = V_{(LOG)}$ or $GND_{(LOG)}$			± 1	μA
$I_{(LOG)}$	Supply current	Data transfer, SCLK = 10 MHz			0.1	mA
$I_{(LED)}$		LED is turned off		0.8	1.6	
$I_{(ANA)}$		LED is turned off		0.8	1.6	
$I_{OH(S03)}$	Segment current	$V_{(Sn)} = 2.5\text{ V}$, $R_{(IREF)} = 4200\ \Omega$	-2.45	-3	-3.45	mA
$I_{OH(S10)}$		$V_{(Sn)} = 2.5\text{ V}$, $R_{(IREF)} = 1260\ \Omega$	-8.5	-10	-11.5	
$I_{OH(S20)}$		$V_{(Sn)} = 2.5\text{ V}$, $R_{(IREF)} = 630\ \Omega$	-17	-20	-23	
$I_{OH(S30)}$		$V_{(Sn)} = 2.5\text{ V}$, $R_{(IREF)} = 420\ \Omega$	-25.5	-30	-34.5	
$\Delta I_{OH(S)}$	Segment current error between bits	$V_{(LED)} = 5\text{ V}$, $R_{(IREF)} = 630\ \Omega$, $V_{(Sn)} = 2.5\text{ V}$		$\pm 3\%$	$\pm 6\%$	
V_{REF}	Voltage reference		1.2	1.26	1.3	V

switching characteristics, $C_L = 15\text{ pF}$

PARAMETER		TEST CONDITIONS	MIN	TYP	MAX	UNIT
t_r	Rise time	SOUT			40	ns
		DSEL			40	
		COMn			80	
		Sn			80	
t_f	Fall time	SOUT			40	ns
		DSEL			40	
		COMn			40	
		Sn			40	
t_d	Propagation delay time	$\overline{\text{LATCH}} - \text{Sn}$			40	ns
		$\overline{\text{SCLK}} - \text{Sn}$			40	
		$\overline{\text{SCLK}} - \text{SOUT}$			40	
		$\overline{\text{DSEL}} - \text{DSEL}$			40	
$t_{(DLH)}$	Propagation delay time	$\overline{\text{CSELn}} - \text{COMn}$			120	ns
		$\overline{\text{DSEL}} - \text{COMn}$			120	
		BLANK - COMn			120	
$t_{(DHL)}$	Propagation delay time	$\overline{\text{CSELn}} - \text{COMn}$			40	ns
		$\overline{\text{DSEL}} - \text{COMn}$			40	
		BLANK - COMn			40	

TLC5920 16x8 BIT LED DRIVER/CONTROLLER

SLAS264 – MARCH 2000

PARAMETER MEASUREMENT INFORMATION

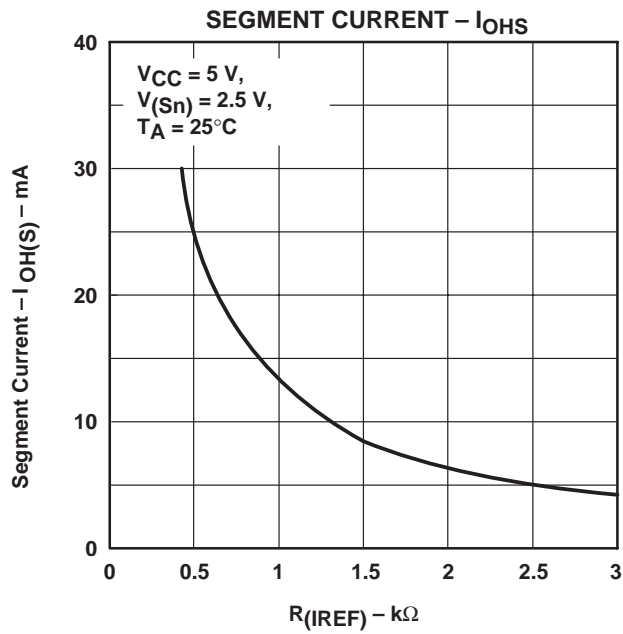
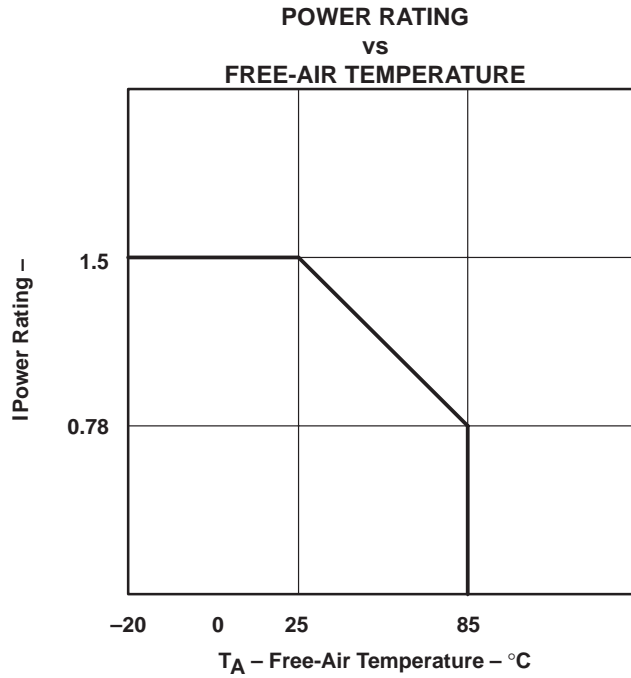

$$I_{OH(S)} = \frac{V_{REF}}{R_{(IREF)}} \times 10$$

TLC5920 16x8 BIT LED DRIVER/CONTROLLER

SLAS264 – MARCH 2000

timing diagram (common driver)

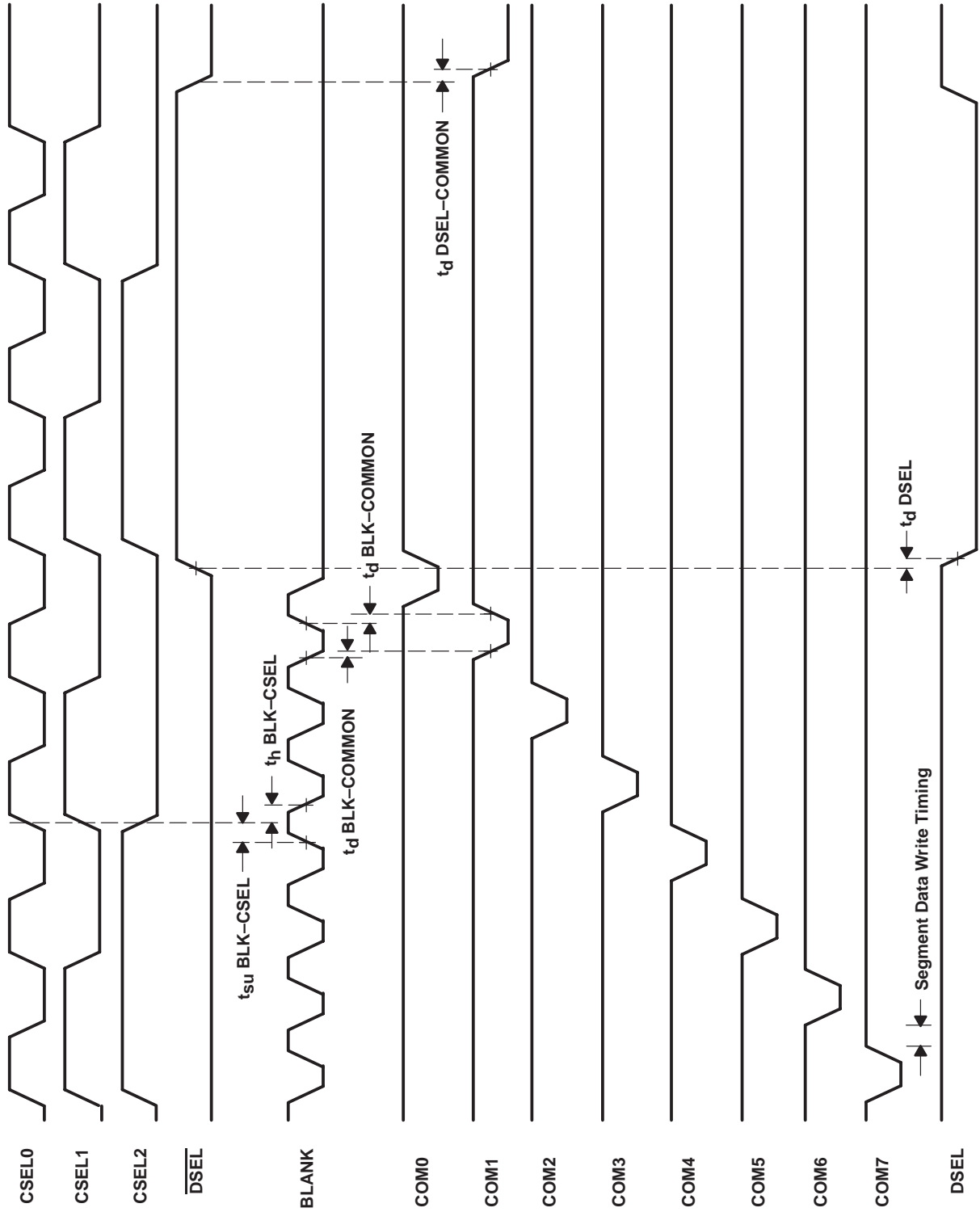

TLC5920
16x8 BIT LED DRIVER/CONTROLLER

SLAS264 – MARCH 2000

timing diagram (segment driver)

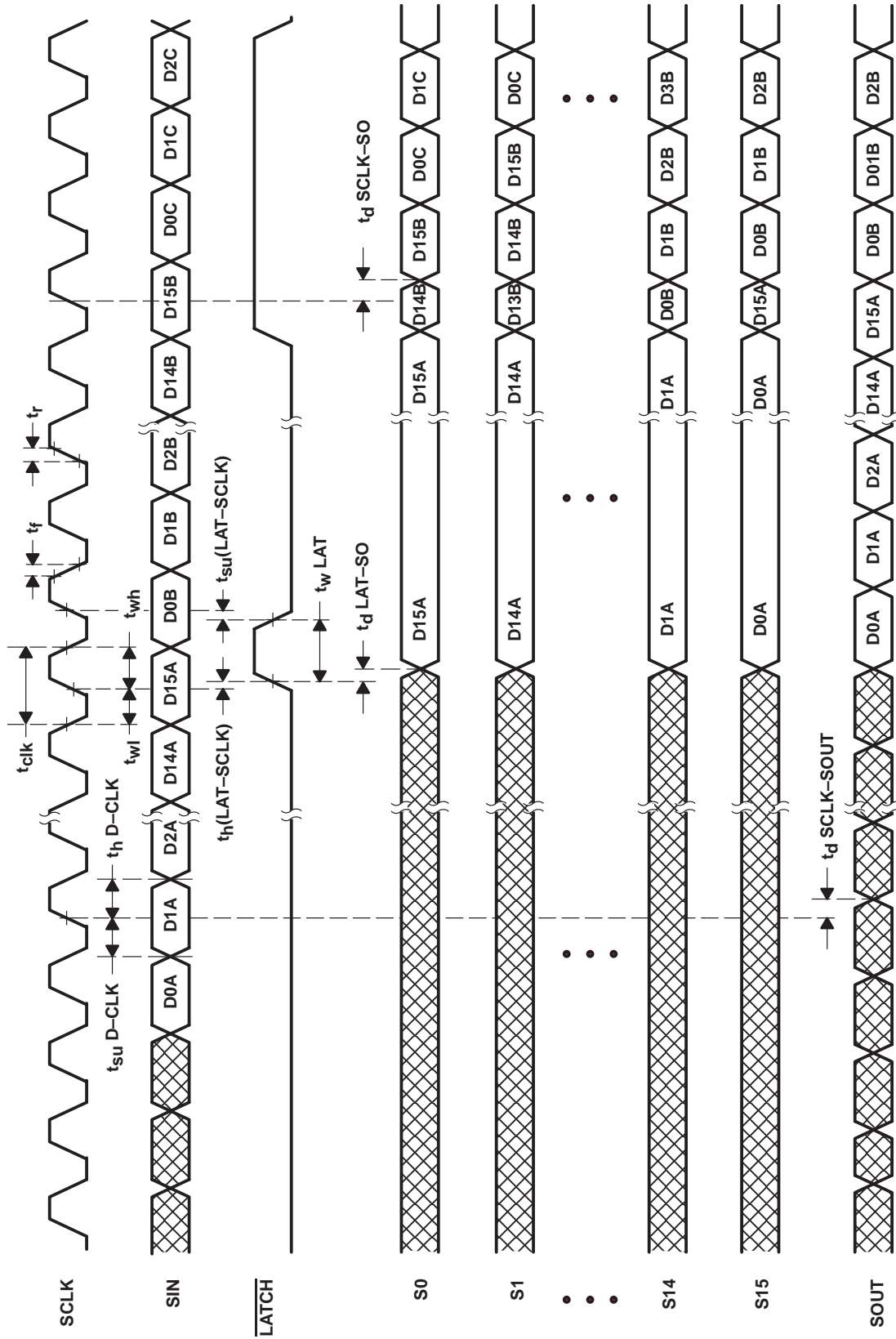

APPLICATION INFORMATION

example 1

The other remaining terminals used for dot matrix LED drive can be utilized for LED lamp drive and other displays.

LEDs driven by TLC5920

cathode common type

LED			TLC5920 QUANTITY	DUTY	DRIVE CURRENT (mA)
TYPE	NO. OF COLOR	QUANTITY			
LAMP	Mono	16	1	Static	30
	Two	8	1	Static	30
7 SEGMENT	Mono	16	1	1/8	30
	Two	8	1	1/8	30
5 x 7	Mono	3	1	1/8	30
	Two	1	1	1/8	30
8 x 8	Mono	2	1	1/8	30
	Two	1	1	1/8	30
16 x 16	Mono	2	2	1/16	20
	Two	1	2	1/16	20
	Three	1	3	1/16	13
24 x 24	Mono	2	3	1/24	13
	Two	1	3	1/24	13

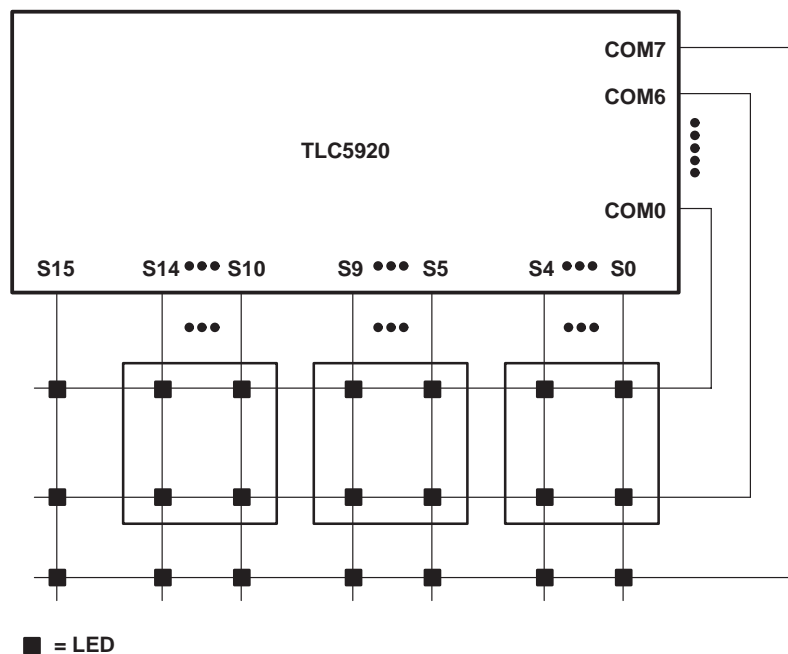

TLC5920 16x8 BIT LED DRIVER/CONTROLLER

SLAS264 – MARCH 2000

APPLICATION INFORMATION

example 2

Using two TLC5920s, an LED with two colors and 16 x 16 dots can be driven. The number of LED arrays can also be increased by making a cascade connection in the application circuit.

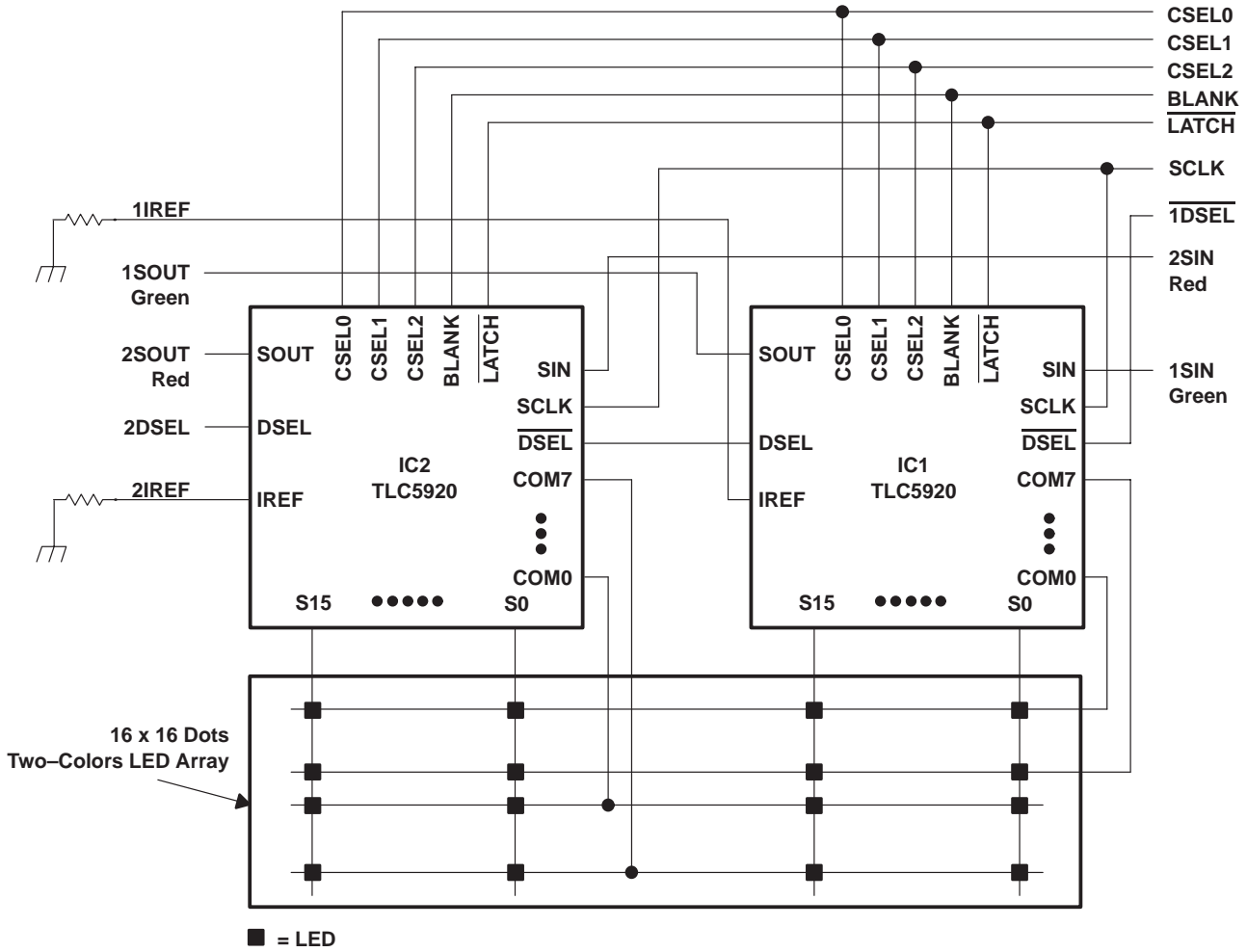

TLC5920 16x8 BIT LED DRIVER/CONTROLLER

SLAS264 – MARCH 2000

MECHANICAL DATA

DL (R-PDSO-G**)

PLASTIC SMALL-OUTLINE PACKAGE

48 PINS SHOWN

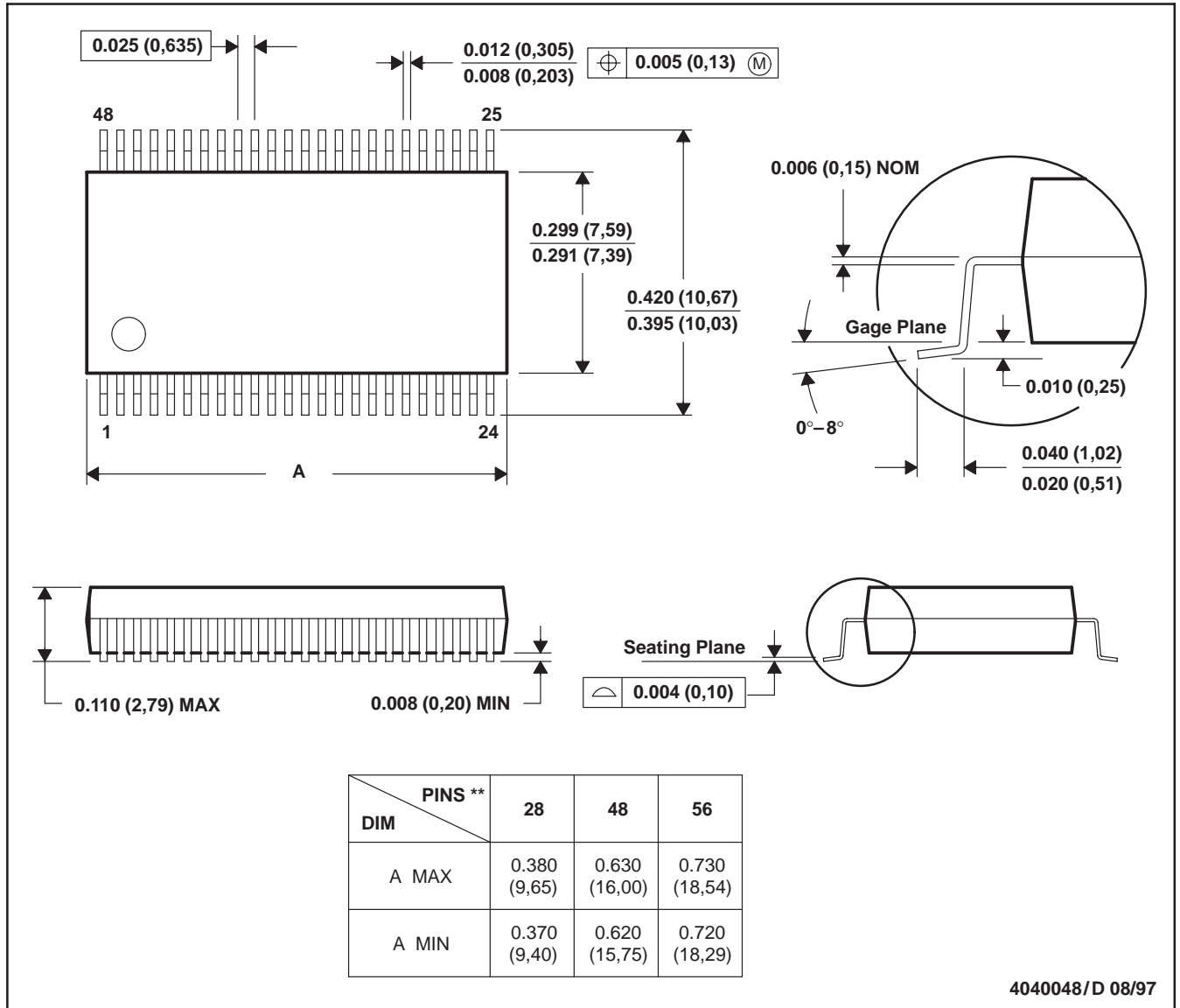

- NOTES: A. All linear dimensions are in inches (millimeters).
 B. This drawing is subject to change without notice.
 C. Body dimensions do not include mold flash or protrusion not to exceed 0.006 (0,15).
 D. Falls within JEDEC MO-118

IMPORTANT NOTICE

Texas Instruments and its subsidiaries (TI) reserve the right to make changes to their products or to discontinue any product or service without notice, and advise customers to obtain the latest version of relevant information to verify, before placing orders, that information being relied on is current and complete. All products are sold subject to the terms and conditions of sale supplied at the time of order acknowledgement, including those pertaining to warranty, patent infringement, and limitation of liability.

TI warrants performance of its semiconductor products to the specifications applicable at the time of sale in accordance with TI's standard warranty. Testing and other quality control techniques are utilized to the extent TI deems necessary to support this warranty. Specific testing of all parameters of each device is not necessarily performed, except those mandated by government requirements.

CERTAIN APPLICATIONS USING SEMICONDUCTOR PRODUCTS MAY INVOLVE POTENTIAL RISKS OF DEATH, PERSONAL INJURY, OR SEVERE PROPERTY OR ENVIRONMENTAL DAMAGE ("CRITICAL APPLICATIONS"). TI SEMICONDUCTOR PRODUCTS ARE NOT DESIGNED, AUTHORIZED, OR WARRANTED TO BE SUITABLE FOR USE IN LIFE-SUPPORT DEVICES OR SYSTEMS OR OTHER CRITICAL APPLICATIONS. INCLUSION OF TI PRODUCTS IN SUCH APPLICATIONS IS UNDERSTOOD TO BE FULLY AT THE CUSTOMER'S RISK.

In order to minimize risks associated with the customer's applications, adequate design and operating safeguards must be provided by the customer to minimize inherent or procedural hazards.

TI assumes no liability for applications assistance or customer product design. TI does not warrant or represent that any license, either express or implied, is granted under any patent right, copyright, mask work right, or other intellectual property right of TI covering or relating to any combination, machine, or process in which such semiconductor products or services might be or are used. TI's publication of information regarding any third party's products or services does not constitute TI's approval, warranty or endorsement thereof.