

# SIEMENS

## Smart Quad Channel Low-Side Switch

TLE 5216 G

SPT-IC

### Features

- Overload protection
- Short circuit protection
- Cascadeable serial diagnostic interface
- Overvoltage protection
- $\mu$ C compatible input
- Electrostatic discharge (ESD) protection

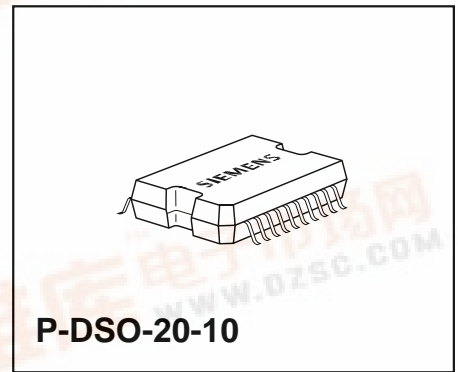

Type	Ordering Code	Package
▼ TLE 5216 G	Q67006-A9206	P-DSO-20-10
▼ New Type		

### Application

- All kinds of resistive and inductive loads (relays, electromagnetic valves)
- $\mu$ C compatible power switch for 12 V applications
- Solenoid control switch in automotive and industrial control systems

## General Description

Quad channel Low-Side Switch in Smart Power Technology (SPT) with four separate LOW active inputs and four open drain DMOS output stages. The TLE 5216G is protected by embedded protection functions and designed for automotive and industrial applications.

## Product Summary

Parameter	Symbol	Values	Unit
Supply voltage	$V_S$	6 ... 30	V
Drain source clamping voltage (OUT1 - OUT4)	$V_{DS(AZ)max}$	75	V
ON resistance	$R_{ON(typ)}$	0.35	$\Omega$
Output current	$I_D$	$4 \times 2$	A

## Pin Configuration

(top view)

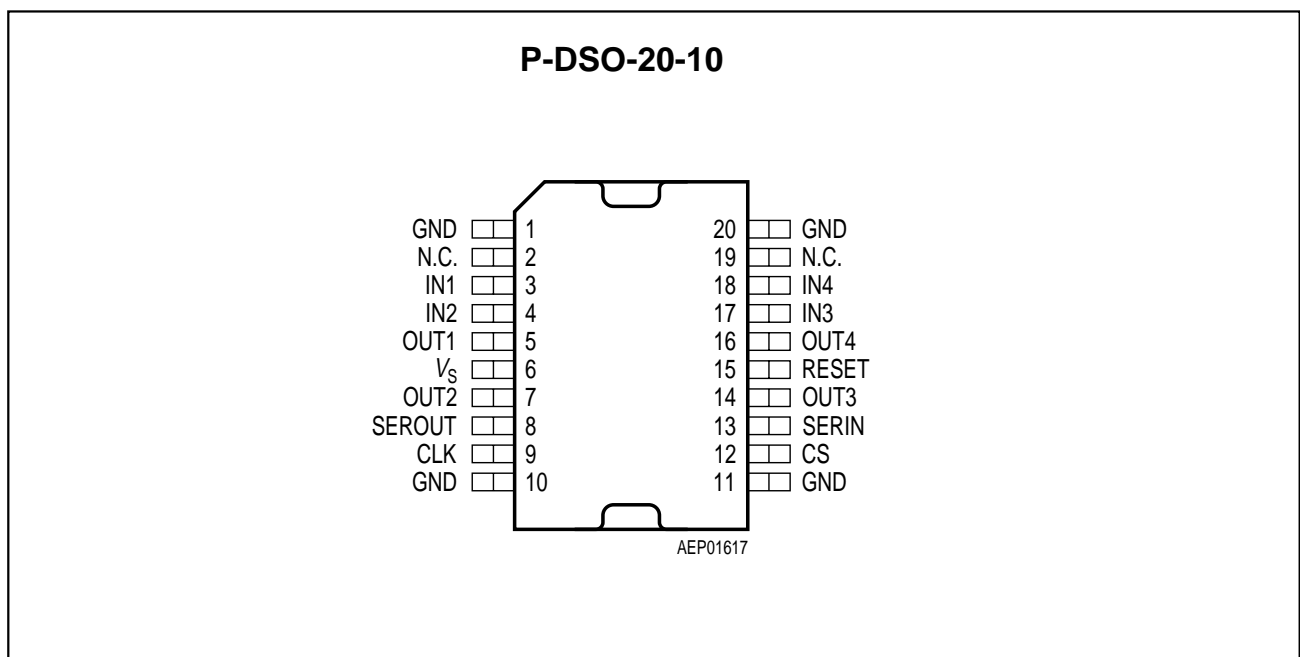
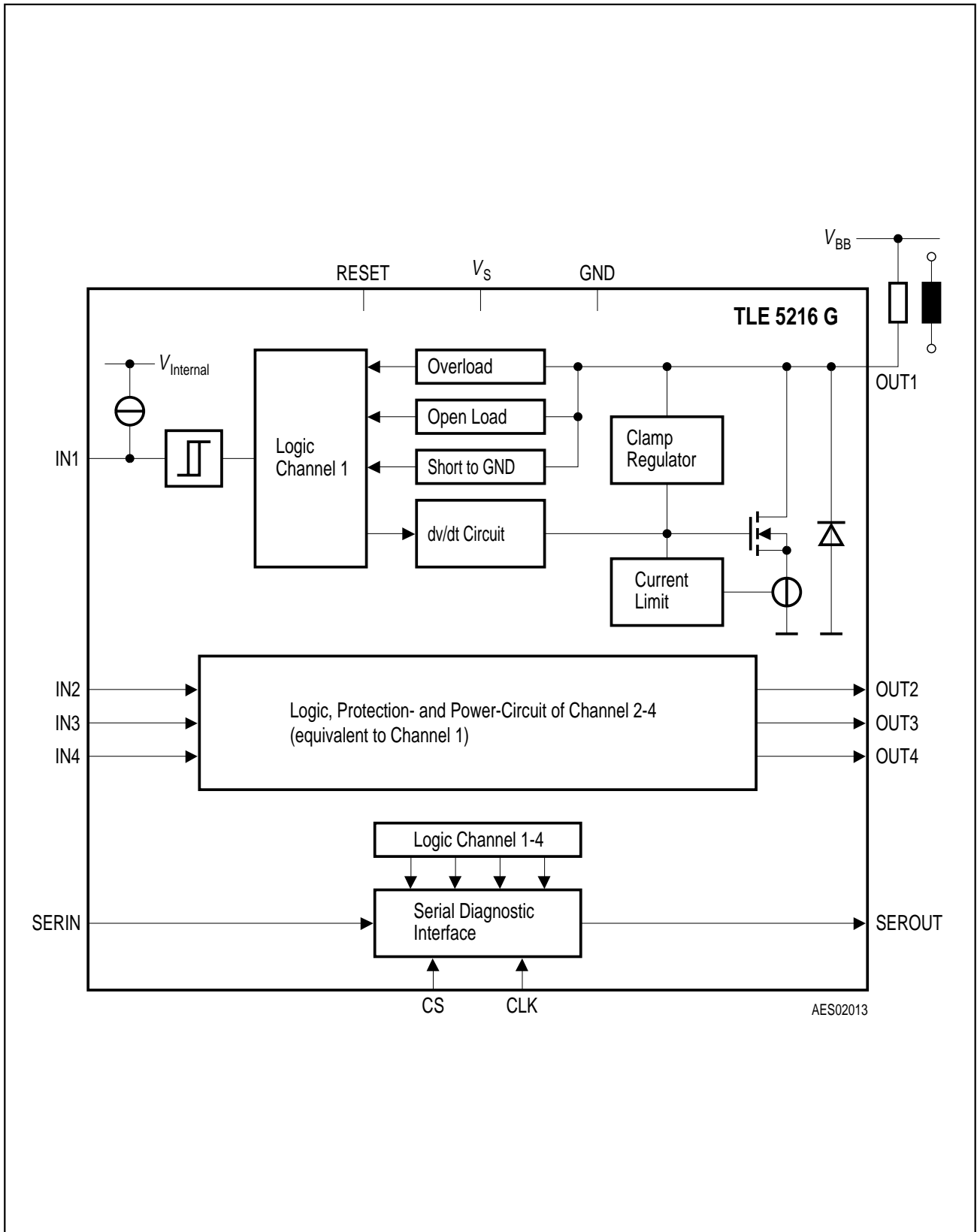

**Figure 1**

---

**Pin Definitions and Functions**

Pin No.	Symbol	Function
3	IN1	Input switch 1; active LOW; internal pull-up
4	IN2	Input switch 2; active LOW; internal pull-up
5	OUT1	Output switch 1; overload and shorted load protected
6	$V_s$	Supply voltage
7	OUT2	Output switch 2; overload and shorted load protected
8	SEROUT	Data-out of serial diagnostic interface; open drain
9	CLK	Clock for serial diagnostic interface
1, 10, 11, 20	GND	Ground
12	CS	Chip select for serial diagnostic interface; internal pull-up
13	SERIN	Data-in of serial diagnostic interface; internal pull-up
14	OUT3	Output switch 3; overload and shorted load protected
15	RESET	Reset; active LOW; shuts down all outputs and resets the error flags
16	OUT4	Output switch 4; overload and shorted load protected
17	IN3	Input switch 3; active LOW; internal pull-up
18	IN4	Input switch 4; active LOW; internal pull-up
2, 19	N.C.	Not connected



**Figure 2**  
**Block Diagram**

## Application Description

This IC is specially designed to drive inductive loads up to 2 A nominal current (valves, relays, etc.). Integrated clamp-diodes limit the output voltage when inductive loads are turned off.

For the detection of errors at the load there is a serial diagnostic interface, which monitors the following errors for every output separately:

- open load in inactive mode
- shorted output (shorted to ground) in inactive mode
- overload or shorted load in active mode

## Circuit Description

The block diagram shows the four independent power drivers with the referring logic block and the serial diagnostic interface which stores and transfers the diagnostic signals to the external circuit. Each power switch connects a high side load to ground when a LOW signal applies at the inputs. To protect the IC against short circuit and over load each output is provided with a current limitation and a delayed overload shutdown. The slew rate of the switching process is limited internally.

The integrated clamp diodes limit the voltage at the output to  $V_{DS(AZ)}$ , when inductive loads are switched off. The maximum power dissipation, which is given from the static and dynamic thermal resistance, limits the allowable inductive energy. A diode in parallel to every output clamps negative voltage.

All outputs, preferably the outputs 1 and 2 and the outputs 3 and 4 may be used in parallel (no addition of max. freewheeling energy).

A curve of the output voltage is shown in **figure 6**.

The diagnostic block monitors the voltages across the power switch. If in active mode (LOW level input) there is a higher voltage than  $V_{DS(OV)}$  for a time longer than  $t_{VDS(OV)}$ , the diagnostic block will show an overload in the error register and the affected power switch will be shut off. The switch can only be reactivated if the corresponding input is switched off and then on again.

In inactive mode (HIGH level at input) open load or shorted output (shorted load to ground) is detected and signalled to the serial diagnostic interface. If the voltage across the power switch is lower than  $V_{DS(OL)}$  for the time  $t_{VDS(OL)}$  (min. 50  $\mu$ s) open load is identified. If the voltage is even lower than  $V_{DS(SH)}$  for the time  $t_{VDS(SH)}$  (min. 30  $\mu$ s) "shorted to ground" is detected. An internal voltage divider will pull the output to the voltage  $V_{DS}$  if there is an open load.

A new error on the same output stage will over-write the old error report. The protocol of the serial diagnostic interface includes independent error reports for each output driver.

As soon as an error is latched into the error register the serial data output (SEROUT) of the interface will go LOW (while CS is still HIGH). If the chip select gets a LOW signal

(CS = L), all error reports can be shifted out serially. The rising edge of the CS will reset all error registers. The function of the serial diagnostic interface is shown in **figure 7**.

The data input (SERIN) allows several TLE 5216 G or other serial diagnostic interfaces to be cascaded.

A LOW signal on the reset pin (RESET) or a supply voltage lower than the operating range (4.5 V) will erase the error register and disable all four power switches.

### Absolute Maximum Ratings

$T_j = -40\text{ °C to }150\text{ °C}$

Parameter	Symbol	Values	Unit	
Supply voltage	$V_S$	- 2 ... 40	V	
Input voltages IN1 ... IN4, SERIN, CLK, CS, RESET	$V_{IN}$	- 0.3 ... 7	V	
Status output voltage Data OUT (SEROUT)	$V_{SEROUT}$	- 0.3 ... 10	V	
Operating temperature range	$T_j$	- 40 ... 150	°C	
Storage temperature range	$T_{Stg}$	- 50 ... 150	°C	
Output current per channel	$T_j = 25\text{ °C}$	$I_{D(AZ)}$	- 3.8 ... 3.8	A
	$T_j = 125\text{ °C}$	$I_{D(AZ)}$	- 2.95 ... 2.95	A
Ground pin current	$T_j = 25\text{ °C}$	$I_{GND}$	- 10 ... 10	A
	$T_j = 125\text{ °C}$	$I_{GND}$	- 8 ... 8	A
Thermal resistance (junction-case static) See diagrams P-DSO-20-10	$R_{thJC}$	5	K/W	
Transient thermal impedance	$t_p = 100\text{ }\mu\text{s}$ ; square pulse	$Z_{thJC}$	0.5	K/W
	$t_p = 100\text{ }\mu\text{s}$ ; triangle pulse	$Z_{thJC}$	0.2	K/W

*Note: Maximum ratings are absolute ratings; exceeding only one of these values may cause irreversible damage to the integrated circuit.*

## Operating Range

Parameter	Symbol	Limit Values		Unit
		min.	max.	
Supply voltage	$V_S$	6	30	V
Supply voltage outputs switchable; no diagnostic	$V_S$	4.5		V
Input LOW voltage	$V_S > 6\text{ V}$ $V_{INL}$	- 0.3	1	V
Input HIGH voltage	$V_S > 6\text{ V}$ $V_{INH}$	2	6	V
Clock input HIGH voltage	$V_S > 6\text{ V}$ $V_{CLKH}$	2.4	6	V
Inverse current at output isolated cooling fin <sup>1)</sup>	$V_S > 6\text{ V}$ $I_D$	- 0.3		A
Junction temperature	$T_j$	- 40	150	°C
Clock frequency	$V_S > 6\text{ V}$ $f_{CLK}$	0	500	kHz
Clock pulse width	$V_S > 6\text{ V}$ $t_{CLKH}, t_{CLKL}$	400		ns
CS pulse width	$V_S > 6\text{ V}$ $t_{CSH}, t_{CSL}$	2		µs
Setup time CS to CLK	$V_S > 6\text{ V}$ $t_{CSC}$	2		µs

<sup>1)</sup> If inverse current occurs at output 2 or 3, then provide external pull-up resistor 5.6 kΩ to + 5 V at input DIN.

*Note: In the operating range the functions given in the circuit description are fulfilled.*

## Electrical Characteristics

$V_S = 6\text{ V to }18\text{ V}$ ;  $T_j = -40\text{ °C to }150\text{ °C}$  (unless otherwise specified)

Parameter	Symbol	Limit Values			Unit
		min.	typ.	max.	

## Power Supply ( $V_S$ )

Supply current	Outputs ON	$I_S$		3.5	8	mA
	Outputs OFF	$I_S$		8	15	mA

## Power Outputs

ON state resistance						
$T_j = 25\text{ °C}$ ; $I_D = 2\text{ A}$ ; all $V_{DS} > 0\text{ V}$	$R_{DS(ON)}$			0.35	0.4	$\Omega$
$T_j = 125\text{ °C}$ ; $I_D = 1.5\text{ A}$ ; $t > 100\text{ }\mu\text{s}$	$R_{DS(ON)}$			0.55	0.63	$\Omega$
Clamping voltage (OUT1 - OUT4)						
$I_D = 1\text{ A}$ ; $0 < T_j < 125\text{ °C}$ ; all $V_{DS} > 0\text{ V}$	$V_{DS(AZ)}$	65	70	75		V
Negative clamping voltage						
$T_j = 25\text{ °C}$ ; $I_D = -0.3\text{ A}$	$V_{DS(AZ)}$	-1			-0.5	V
Current limitation						
$T_j = 0\text{ °C}$ ; $V_{DS} = V_{DS(OV)}$	$I_{D(lim)}$	3.0	3.6	4.2		A
$T_j = 25\text{ °C}$ ; $V_{DS} = V_{DS(OV)}$	$I_{D(lim)}$	2.8	3.3	3.8		A
$T_j = 125\text{ °C}$ ; $V_{DS} = V_{DS(OV)}$	$I_{D(lim)}$	2.25	2.6	2.95		A
Leakage current						
$V_S = 0\text{ V}$ ; $V_{DS} = 12\text{ V}$ ; all $V_{DS} > 0\text{ V}$	$I_R$			0.2	0.5	mA

## Digital Inputs

### Inputs IN1 ... IN4, CS, SERIN

Input LOW current	$0\text{ V} < V_{IN} < 2\text{ V}$	$I_{INL}$	-200	-100	-50	$\mu\text{A}$
Input HIGH current	$V_{IN} = 5\text{ V}$	$I_{INH}$	-20	0	5	$\mu\text{A}$
Input hysteresis		$V_{INHys}$	0.5	0.6		V

## Input Clock (CLK)

Input current	$0\text{ V} < V_{INCLK} < 5\text{ V}$	$I_{INCLK}$	-20	2	5	$\mu\text{A}$
Input hysteresis		$V_{INCLKHys}$	0.5	0.7		V



## Electrical Characteristics (cont'd)

$V_S = 6\text{ V to }18\text{ V}; T_j = -40\text{ °C to }150\text{ °C}$  (unless otherwise specified)

Parameter	Symbol	Limit Values			Unit
		min.	typ.	max.	

### Input Reset

Input current	$0\text{ V} < V_{\text{INR}} < 2\text{ V}$	$I_{\text{INR}}$	- 25	- 10	- 5	$\mu\text{A}$
Input hysteresis		$V_{\text{INRHys}}$	0.5	0.6		V

### Input Currents in Case of Inverse Current at Output

$\Sigma I_D = -0.3\text{ A}; V_S = 0\text{ V}; 0\text{ V} < V_{\text{IN}} < 5\text{ V}$

Inputs CLK, SEROUT, CS, SERIN		$I_{\text{IN}}$			200	$\mu\text{A}$
Inputs IN1 ... IN4		$I_{\text{IN}}$			100	$\mu\text{A}$
Input RESET		$I_{\text{IN}}$			25	$\mu\text{A}$

### Timings

Data valid SEROUT after CLK						
	no 100 % testing	$t_{\text{DDA}}$	0	150	400	ns
Output ON delay	$R_L = 12\ \Omega$	$t_{\text{DON}}$	0	1.4	10	$\mu\text{s}$
Output OFF delay	$R_L = 12\ \Omega$	$t_{\text{DOFF}}$	0	2.4	10	$\mu\text{s}$
Difference of delays	$R_L = 12\ \Omega$	$t_{\text{DON}} - t_{\text{DOFF}}$	- 3	- 1	3	$\mu\text{s}$
Output slew rate falling	$C_L = 1\text{ nF}; 10\text{ V} \rightarrow 2\text{ V}$	$S_f$	- 15	- 8	- 5	$\text{V}/\mu\text{s}$
Output slew rate rising	$I_D = 1\text{ A}; 5\text{ V} \rightarrow 55\text{ V}$	$S_r$	10	14	20	$\text{V}/\mu\text{s}$

### Diagnostic Output (SEROUT)

Output leakage current	$V_{\text{SEROUT}} = 5\text{ V}$	$I_{\text{SEROUTH}}$	0		5	$\mu\text{A}$
Output LOW voltage	$0\text{ V} < I_{\text{SEROUT}} < 1.6\text{ mA}$	$V_{\text{SEROUTL}}$	0	0.2	0.5	V

**Electrical Characteristics** (cont'd)

$V_S = 6\text{ V to }18\text{ V}; T_j = -40\text{ °C to }150\text{ °C}$  (unless otherwise specified)

Parameter	Symbol	Limit Values			Unit
		min.	typ.	max.	

**Diagnostic Functions**

Overload threshold	Output ON	$V_{DS(OV)}$	1.5	2	2.5	V
Overload delay	$V_S = 12\text{ V}; V_{BB} = 12\text{ V}$	$t_{VDS(OV)}$	30	80	200	$\mu\text{s}$
Open load output voltage	$V_S = 6.5\text{ V};$ outputs OFF	$V_{DS}$	3.3	3.8	4.3	V
		$V_S = 12.5\text{ V}$	$V_{DS}$	6.7	7.7	8.7
Differential open load output resistance	outputs OFF	$R_D$	5	15	40	$\text{k}\Omega$
Open load threshold	$V_S = 6.5\text{ V};$ outputs OFF	$V_{DS(OL)}$	4.3	4.7	5.2	V
		$V_S = 12.5\text{ V}$	$V_{DS(OL)}$	9.3	10.2	11
Open load delay	$V_S = 12\text{ V}$	$t_{VDS(OL)}$	50	130	250	$\mu\text{s}$
Shorted to ground threshold	$V_S = 6.5\text{ V};$ outputs OFF	$V_{DS(SH)}$	2.4	2.8	3.3	V
		$V_S = 12.5\text{ V}$	$V_{DS(SH)}$	4.5	5.4	6.3
Shorted to ground delay	$V_S = 12\text{ V}$	$t_{VDS(SH)}$	30	80	200	$\mu\text{s}$

*Note: The listed characteristics are ensured over the operating range of the integrated circuit. Typical characteristics specify mean values expected over the production spread. If not otherwise specified, typical characteristics apply at  $T_A = 25\text{ °C}$  and the given supply voltage.*

Test Circuits

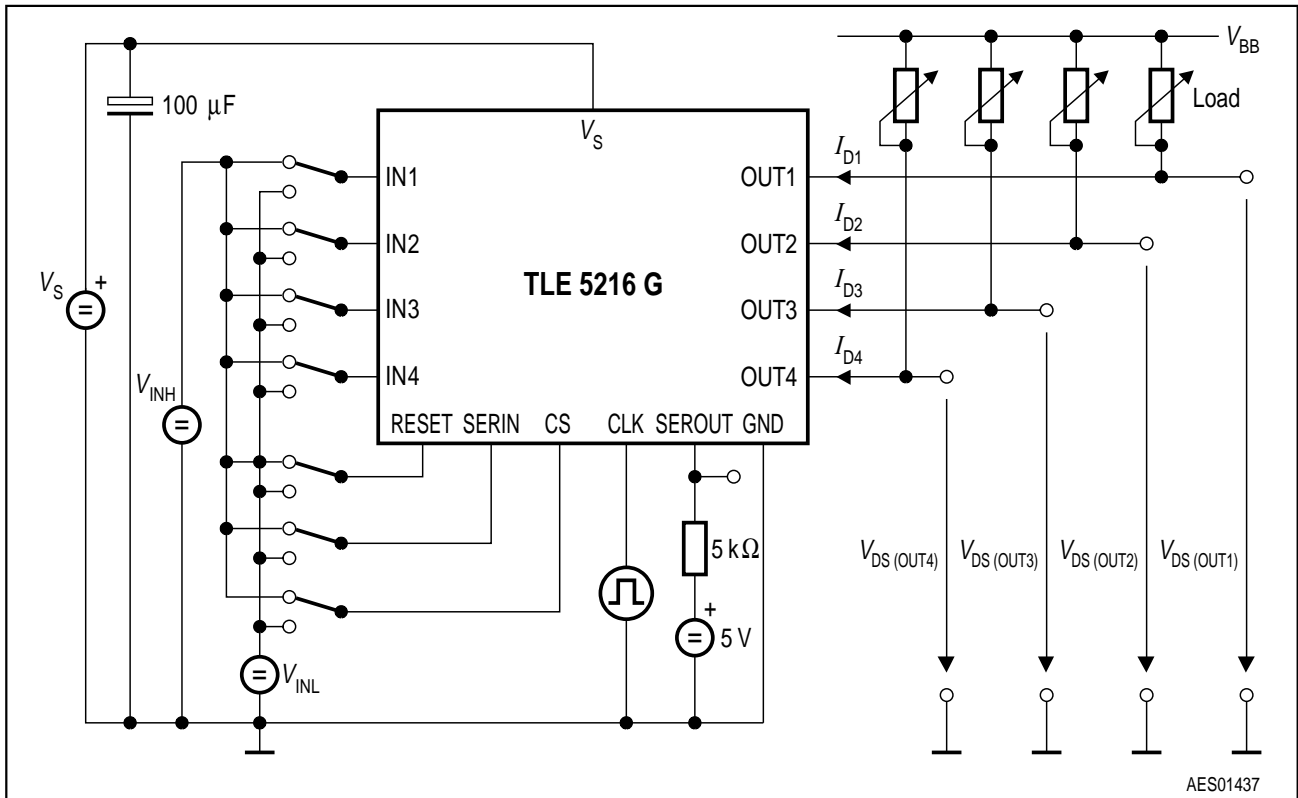

Figure 3  
Test Circuit 1

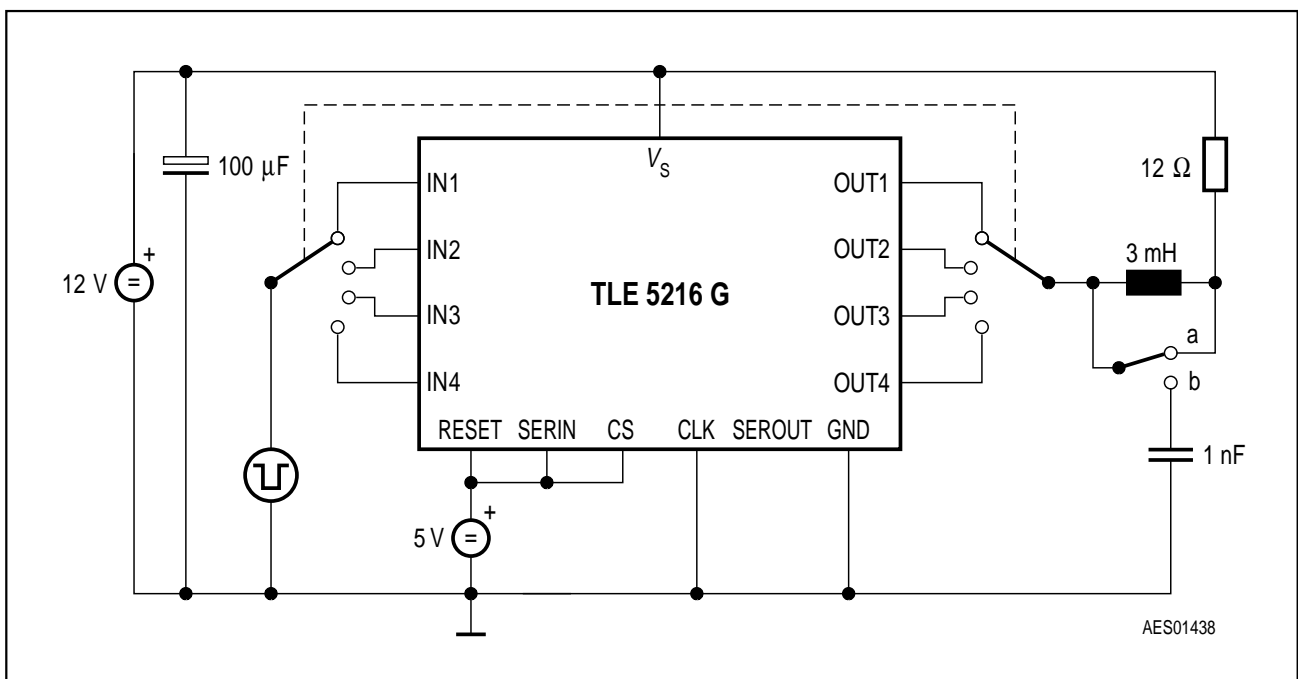

Figure 4  
Test Circuit 2

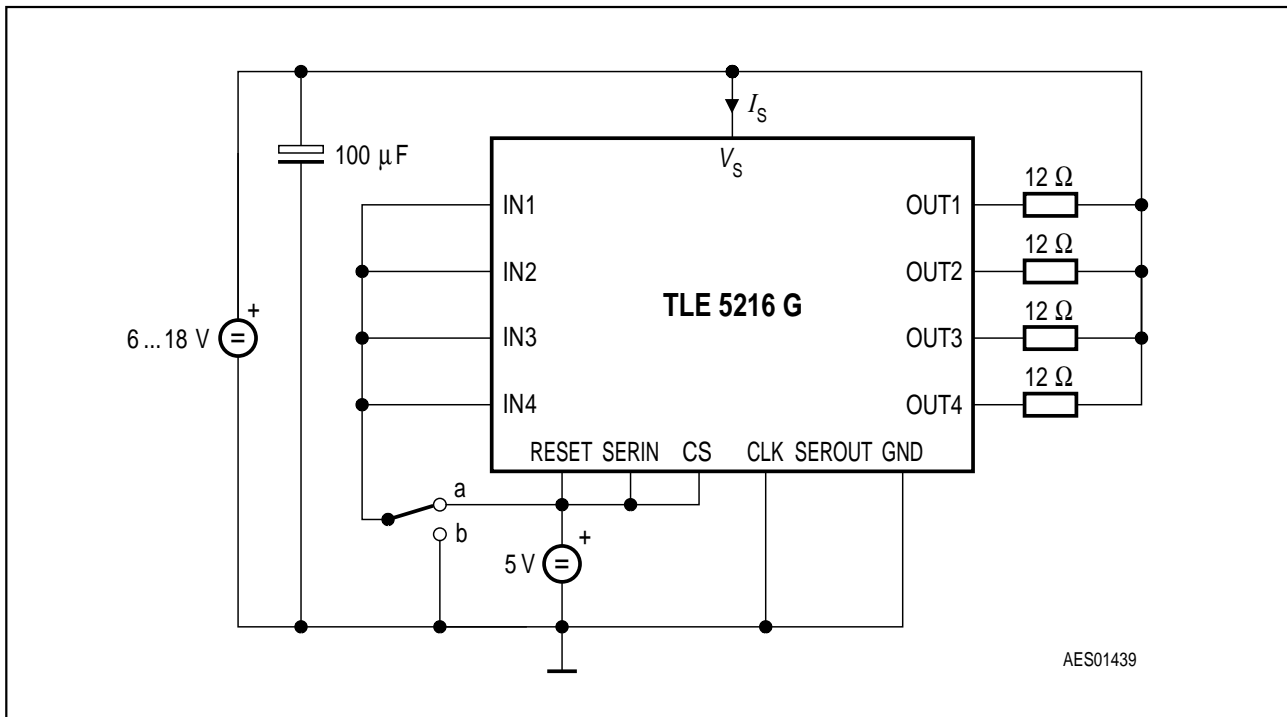

Figure 5  
Test Circuit 3

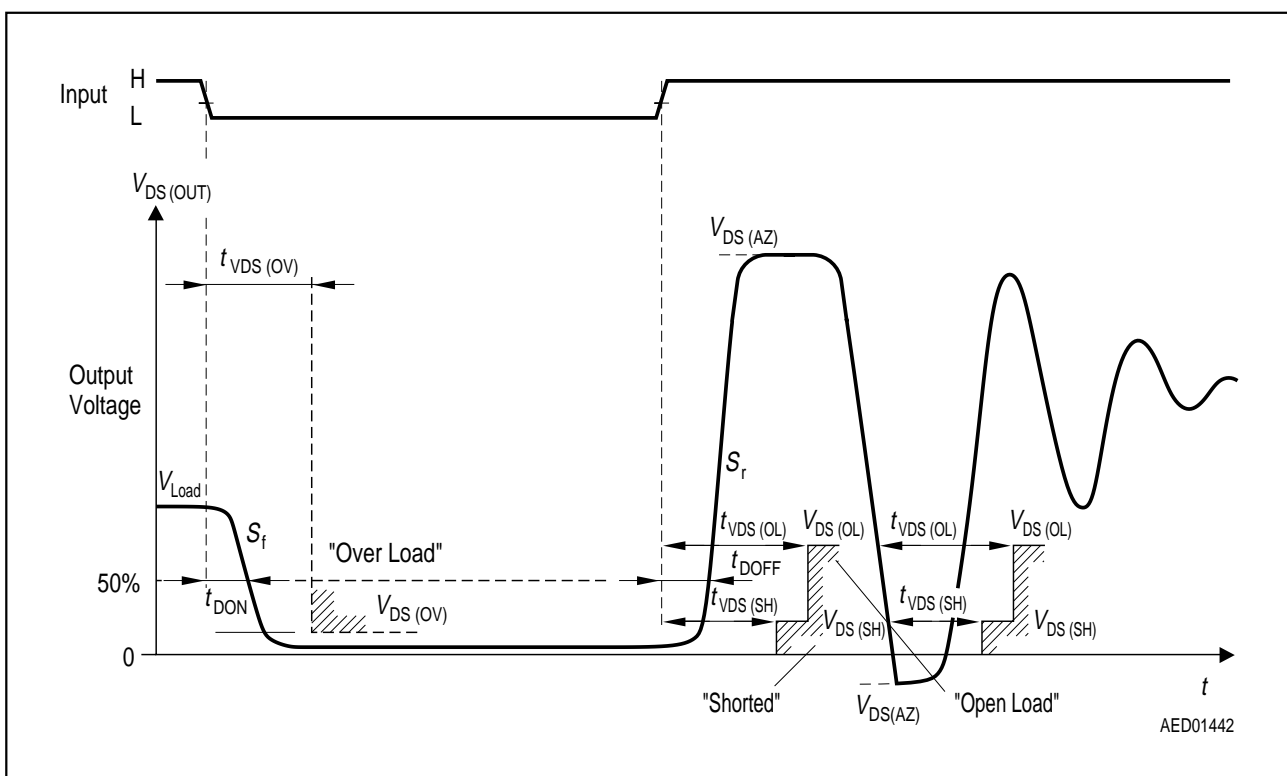

Figure 6  
Switching Waveforms with Inductive Loads

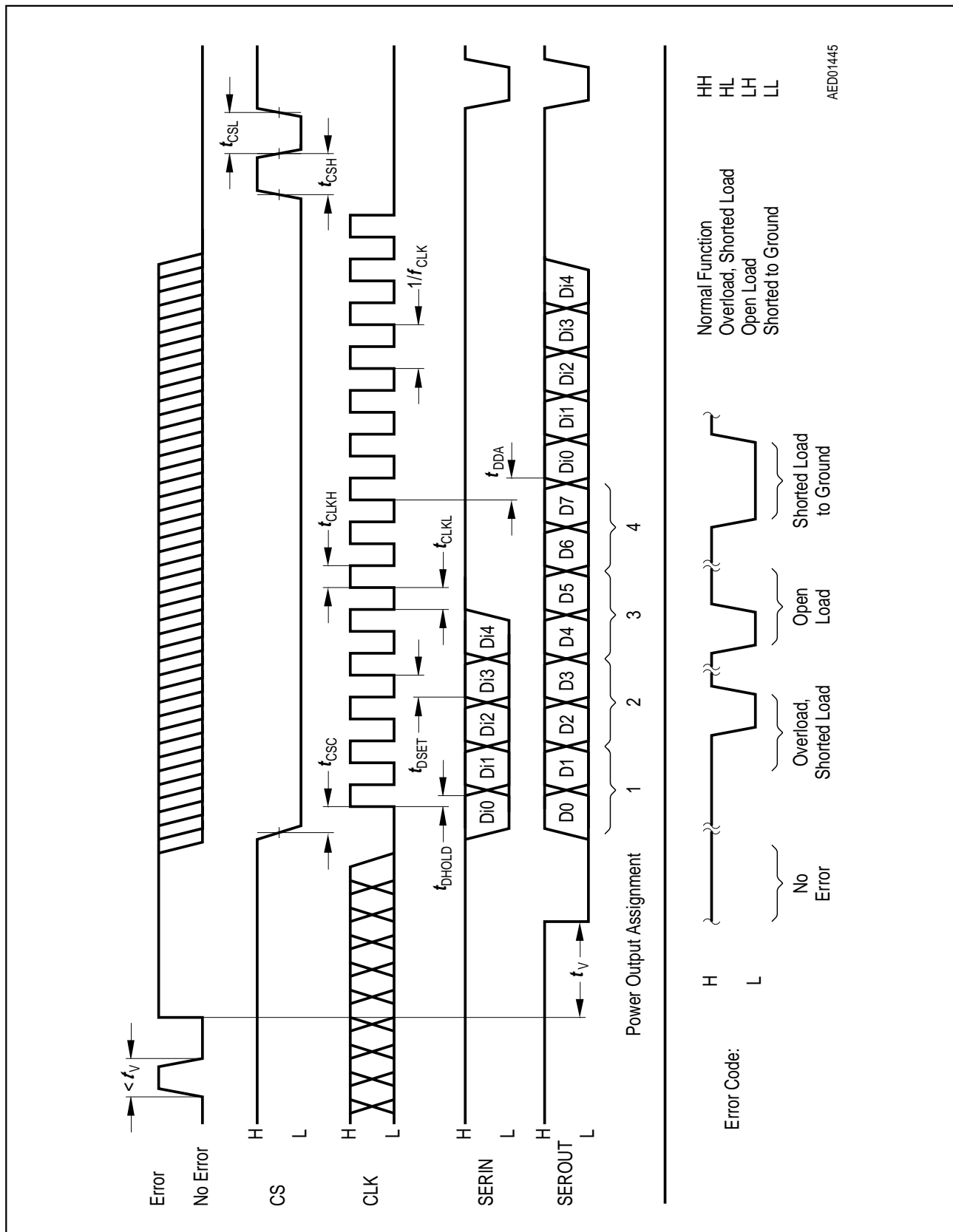
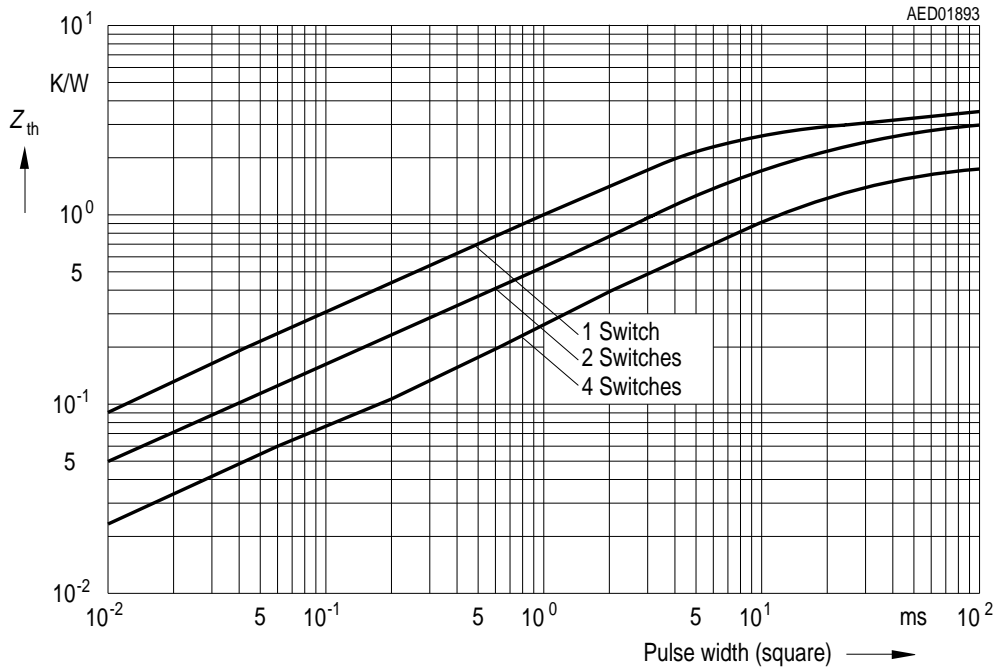

Figure 7  
Serial Diagnostic Interface Timing Diagram

Thermal Resistance for P-DSO-20-10



Note: Thermal resistance is measured at  $T_C = 25^\circ\text{C}$  and  $T_{jpeak} = 45^\circ\text{C}$ . Multiple switches are equally loaded at the same time.

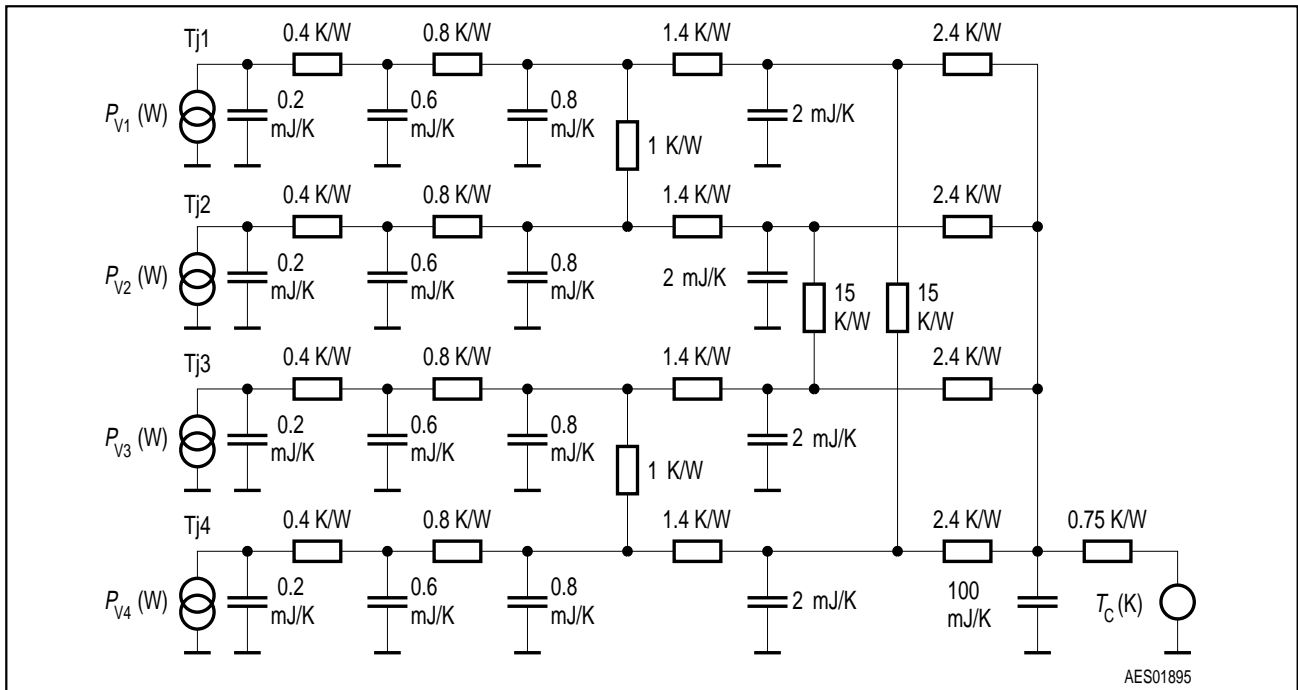
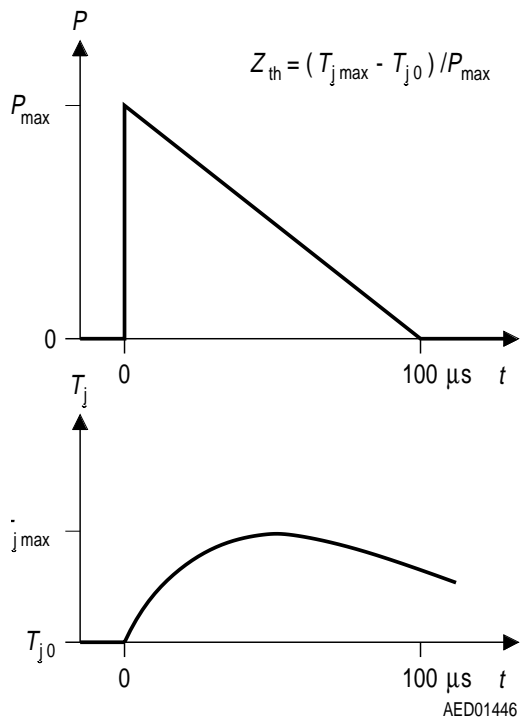

Figure 8  
Thermal Equivalent Circuit for P-DSO-20-10

Note: Thermal equivalent circuit is valid at  $T_C = 25^\circ\text{C}$  and  $25^\circ\text{C} < T_j < 45^\circ\text{C}$ . At  $T_C = 110^\circ\text{C}$  and  $110^\circ\text{C} < T_j < 130^\circ\text{C}$ ,  $Z_{th}$  is 15% higher. For high power transients with  $T_{jmax} - T_C \leq 100\text{K}$  add 25% headroom for thermal non-uniformity.

**Definition of Dynamic Thermal Resistance (triangle Pulse)**



**Maximum Freewheeling Energy for Inductive Loads**

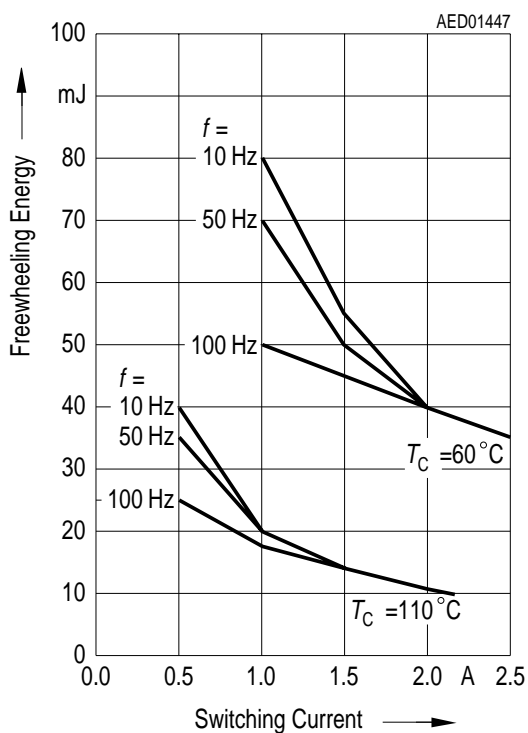

**Maximum Freewheeling Energy for Inductive Loads with Various Switches in Parallel  $T_c = 110^\circ\text{C}$ ,  $f = 10\text{ Hz}$**

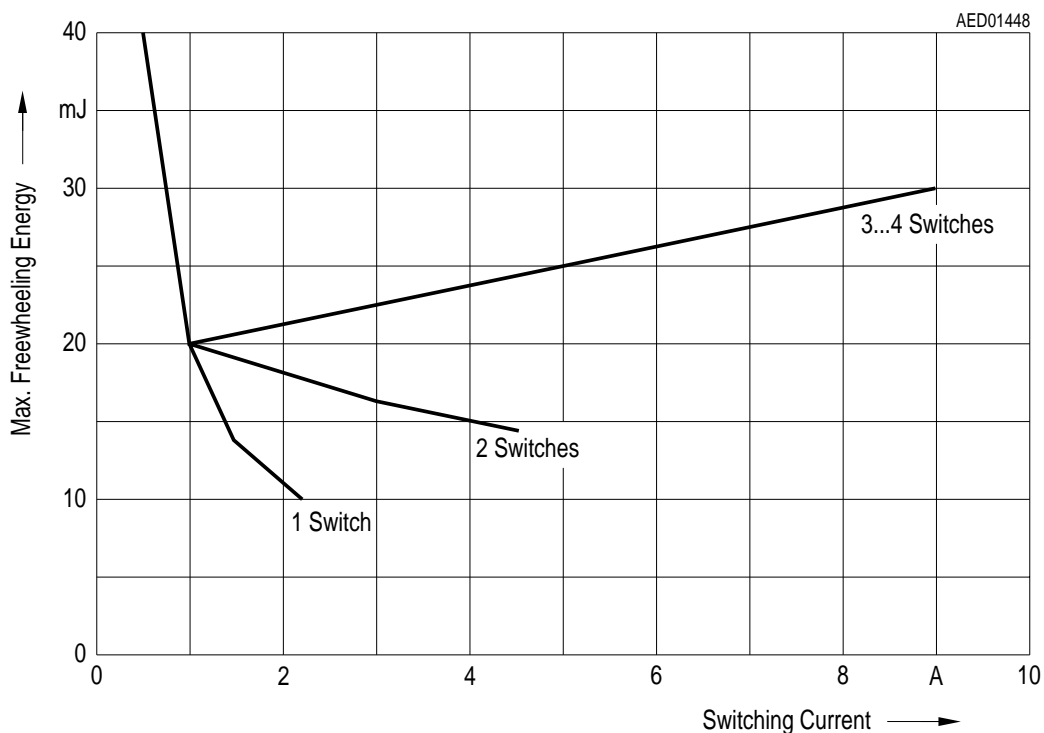

**Diagnostic Threshold versus Supply Voltage**

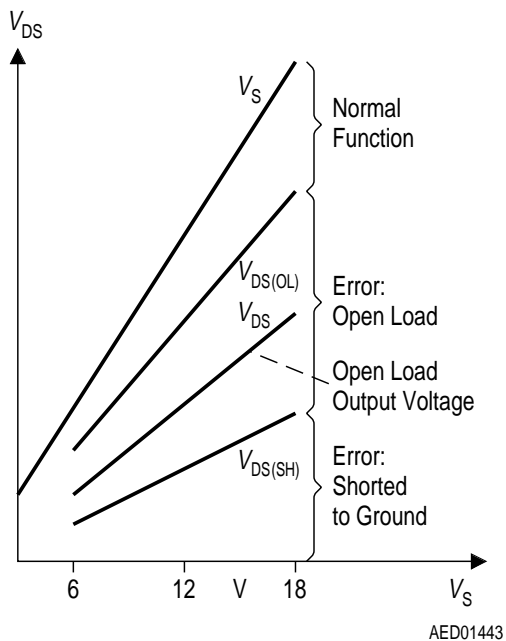

**Current Limitation versus Temperature**

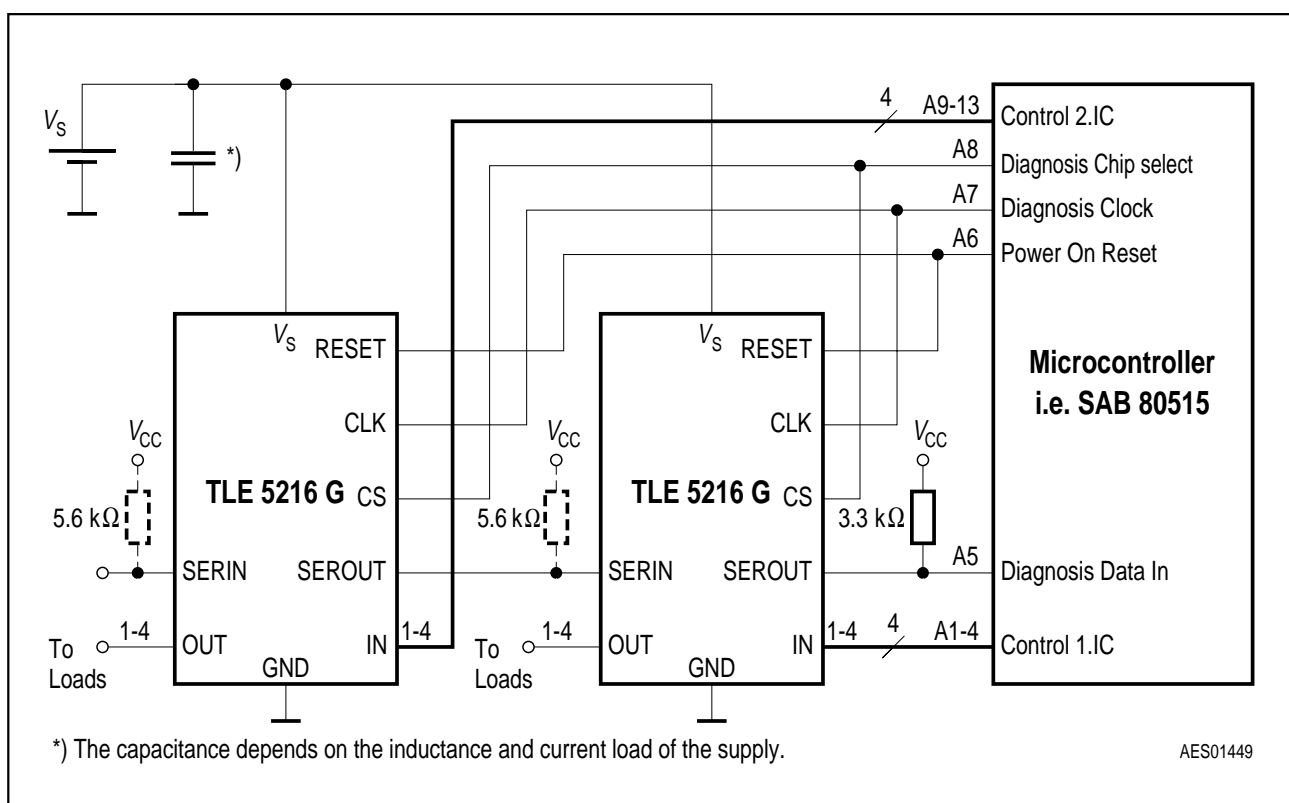
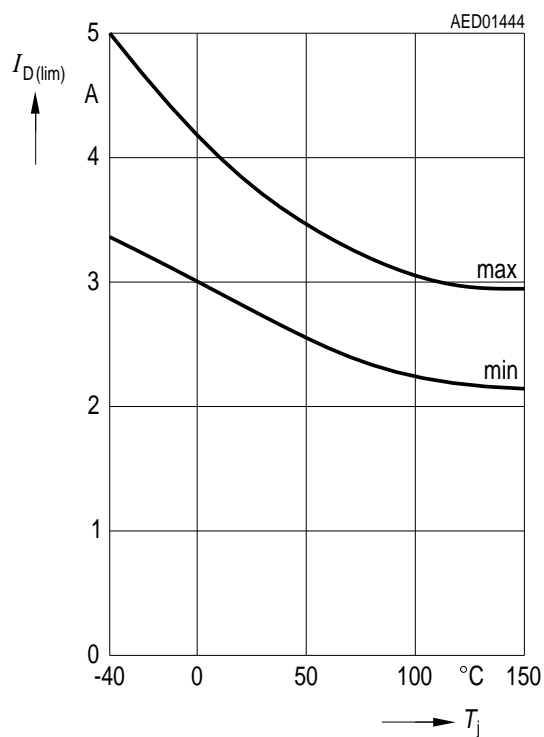
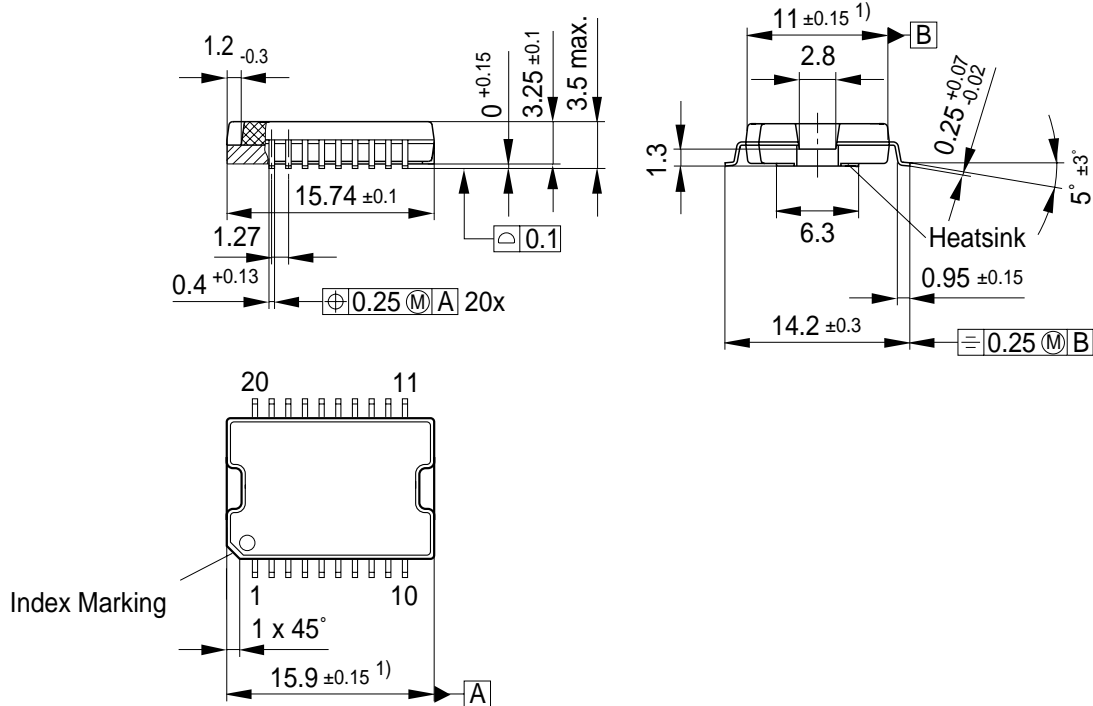

**Figure 9**  
**Application Circuit**



Package Outlines

**P-DSO-20-10**  
(Plastic Dual Small Outline Package)



1) Does not include plastic or metal protrusion of 0.15 max. per side

GPS05791

GPS05791

**Sorts of Packing**

Package outlines for tubes, trays etc. are contained in our Data Book "Package Information".

SMD = Surface Mounted Device

Dimensions in mm