



## ABS System IC

TLE 6210  
TLE 6211

# 1 Overview

## 1.1 Features

- 5 V, 800 mA linear regulator
- Undervoltage/overvoltage reset
- Undervoltage and overvoltage logout
- Digital watchdog supervision for 2 Microcontrollers
- (motor) relay driver
- (valve) relay driver
- Inverted or non inverted lamp relay driver
- Enable output
- Overtemperature and overcurrent protection

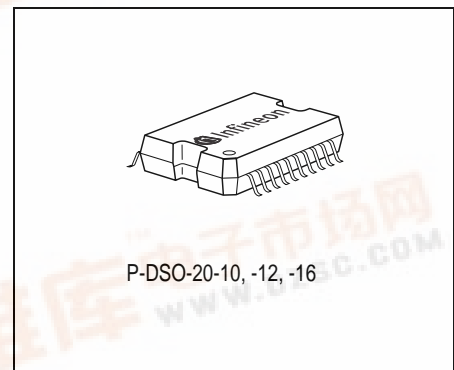

Type	Ordering code	Package/Shipment
TLE 6210 C	on request	Bare dice
TLE 6210 G	on request	P-DSO-20-12, Tape and Reel
TLE 6211 G	on request	P-DSO-20-12, Tape and Reel

## 1.2 Functional Description

The TLE 6210 and TLE 6211 are integrated circuit consisting of a 5 V voltage regulator with 800 mA current capability, different relay driver outputs and supervision logic. The supervision logic watches the input voltage and the regulator output voltage both for over-voltage and under-voltage. In addition two window watchdogs supervise the correct operation of 2 independent watchdog signals, e.g. from two Microcontrollers.

The TLE 6210 and TLE 6211 are designed especially for the severe conditions of ABS/ASR applications in an automotive environment.

### 1.3 Block Diagram

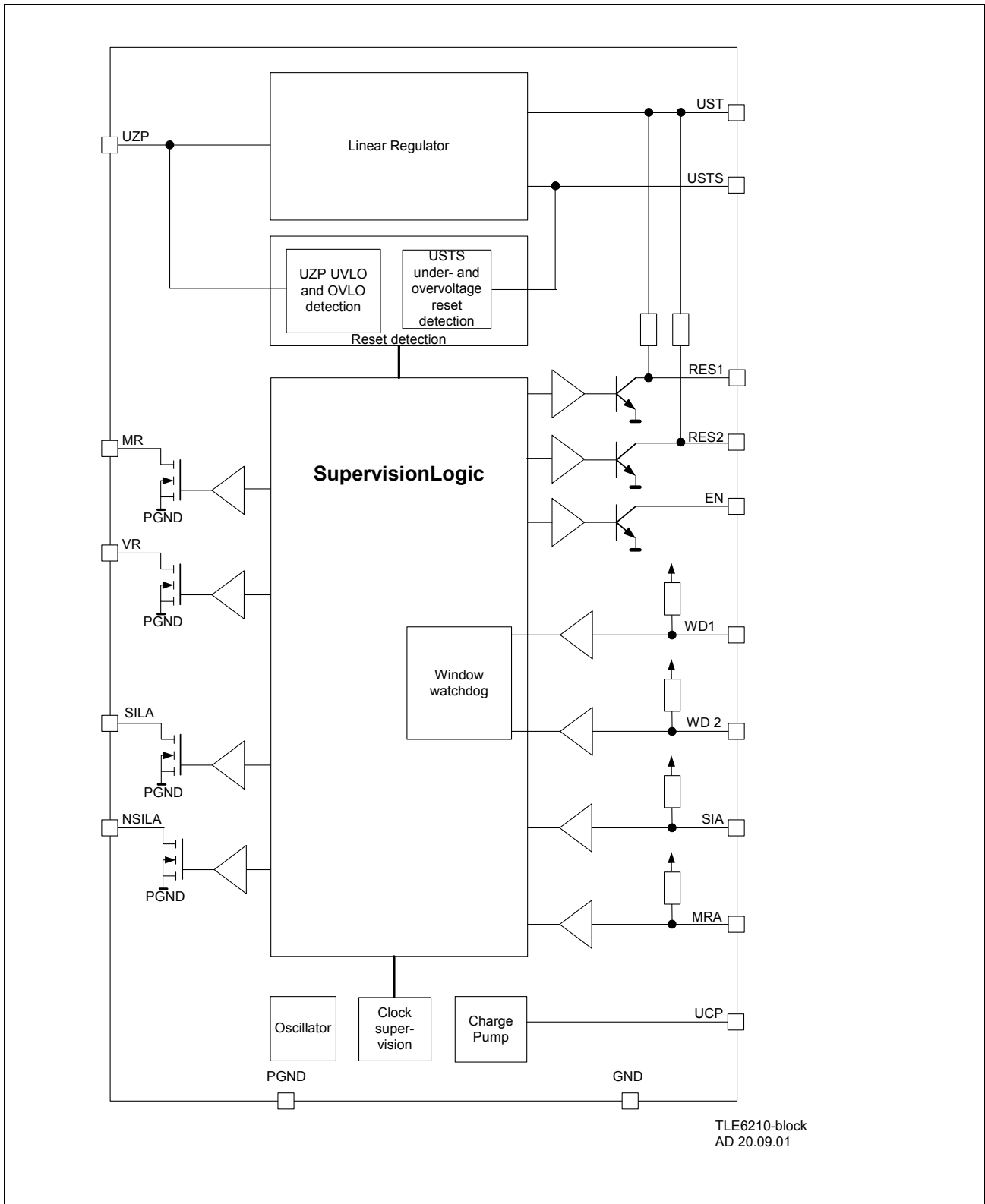

Figure 1 Block Diagram

## 2 Pin / Pad Configuration

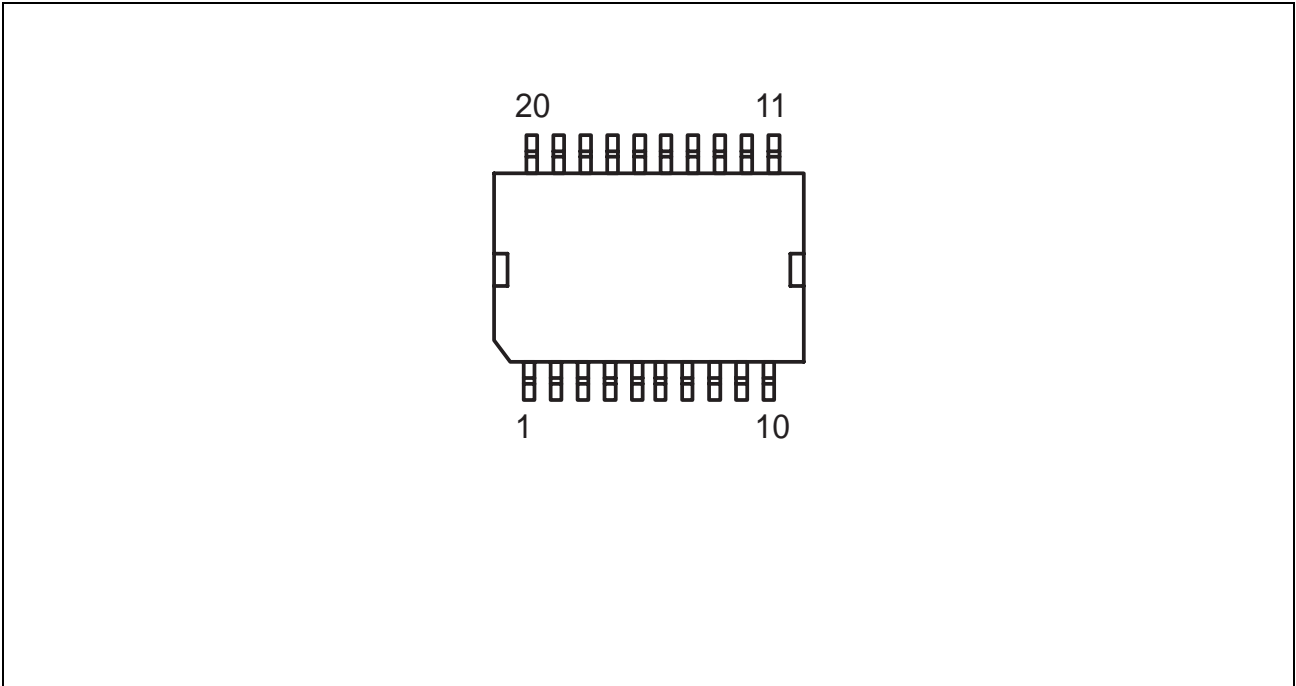

Figure 2 Pin Configuration P-DSO-20-12

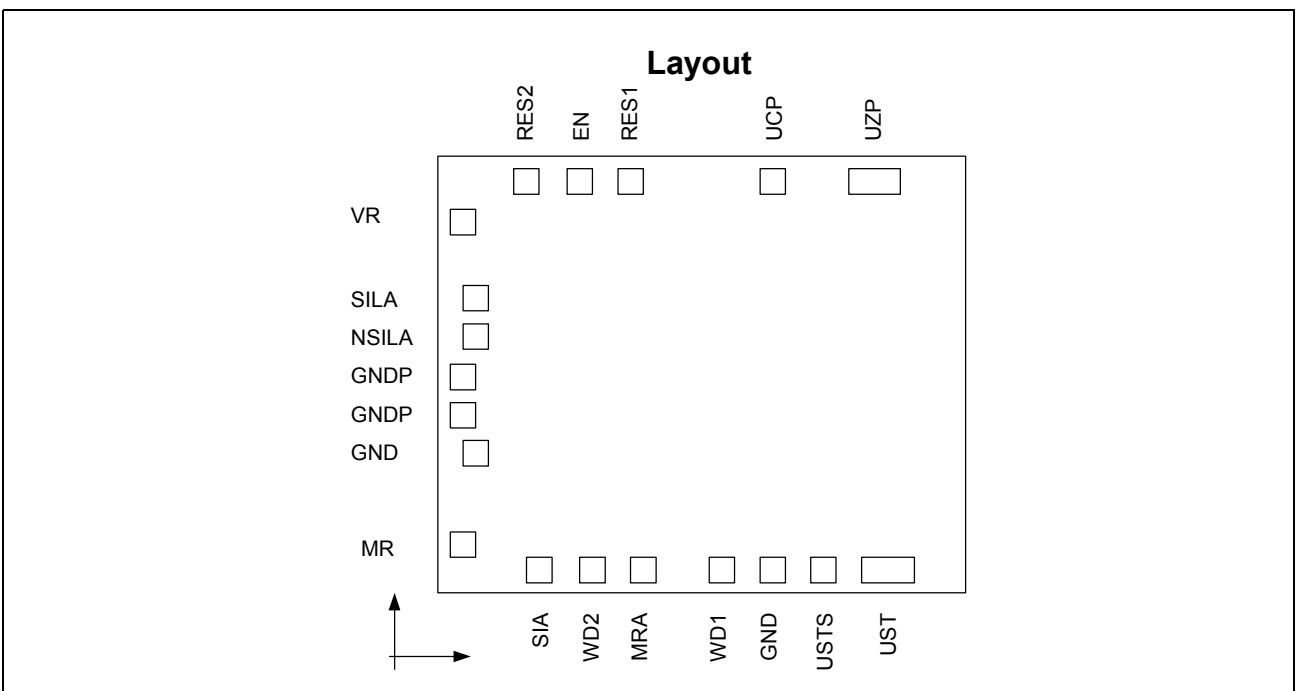

Figure 3 Chip-Layout

Pin / Pad Configuration

Pin / Pad Definitions and Functions

Pin Number		Symbol / Pad Name	Function
TLE 6210 G	TLE 6211G		
1	1	GND	<b>Power GND</b> connection
2	2	N.C.	<b>Not Connected</b>
3	3	$U_{ZP}$	<b>Supply Voltage</b> ; reverse protection diode is required
4	4	$U_{CP}$	<b>Charge Pump Capacitor</b> pin; An external capacitor is the energy storage for the charge pump
5	5	RES1	<b>Reset Output 1</b> ; open collector output with integrated pull-up resistor. A high indicates normal operation; function identical to RES2
6	6	EN	<b>Enable Output</b> ; open collector; low indicates an error condition
7	7	RES2	<b>Reset Output 2</b> ; open collector output with integrated pull-up resistor. A high indicates normal operation; function identical to RES1
8	8	VR	<b>Valve Relay Output</b> ; open drain output
9	–	SILA	<b>Lamp Output</b> ; open drain output; For TLE 6210 CW only
–	9	NSILA	<b>Inverted Lamp Output</b> ; open drain output; For TLE 6211 CW only
10	10	GND	<b>Power Ground</b> connection
11	11	GND	<b>Power Ground</b> connection
12	12	MR	<b>Motor Relay Output</b> ; open drain output
13	13	SIA	<b>Lamp Control Signal Input</b> ; controls SILA/NSILA; a logic high switches SILA off and NSILA on
14	14	WD2	<b>Watchdog Input 2</b>
15	15	MRA	<b>Motor Relay Control Input</b> ; A logic High switches MR on
16	16	WD1	<b>Watchdog Input 1</b>
17	17	GND	<b>Logic Ground</b>
18	18	$U_{STS}$	<b>Sense input</b> for $U_{ST}$ supervision
19	19	$U_{ST}$	<b>5 V Linear Regulator Output</b>
20	20	GND	<b>Ground Connection</b>
Backside metallization		GND	The lead frame connects the pins 1, 10, 11 and 20 to the backside metallization.

### 3 Electrical Characteristics

#### 3.1 Absolute Maximum Ratings

$$-40\text{ °C} \leq T_j \leq 150\text{ °C}$$

#	Parameter	Symbol	Limit Values		Unit	Conditions
			min.	max.		
M1	Supply Voltage	$U_{ZP}$	0	20	V	–
			0	26.5	V	$0 < t_p \leq 5\text{ min.};$ $-40\text{ °C} \leq 80\text{ °C}$
			0	35	V	$0 < t_p \leq 200\text{ ms};$ $f < 0.067\text{ Hz};$ $n \leq 360\text{ cycles}$
			0	35	V	$0 < t_p \leq 50\text{ ms};$ $0 < f_p \leq 1\text{ Hz};$ $n \leq 36000\text{ cycles}$
			-1.5	–	V	$t_p = 2\text{ s}$
M2	Supply Voltage variation	$dU_{ZP}/dt$	–	10	V/ $\mu$ s	–
M3	Output voltage at VR, MR	$U_{VR}, U_{MR}$	–	60	V	VR, MR-DMOS off
M4	Output voltage at SILA	$U_{SILA}$	–	42	V	SILA-DMOS off
M5	Output voltage at NSILA	$U_{NSILA}$	–	42	V	NSILA-DMOS off
M6	Output voltage at RES1, RES2	$U_{RES1}$ $U_{RES2}$	-0.5	7	V	–
M7	Output voltage at EN	$U_{EN}$	-0.5	7	V	–
M8	Input Voltage at WD1, WD2, MRA, SIA	$U_{WD1}, U_{WD2}$ $U_{MRA}, U_{SIA}$	-0.5	7	V	–
M9	Voltage $U_{CP}$	$U_{CP}$	-0.5	20	V	–
M10	Storage Temperature	$T_{stg}$	-55	150	°C	–
M11	Junction Temperature	$T_j$	-40	150 175	°C °C	continuous short term (< 50 h over lifetime)

Electrical Characteristics

3.1 Absolute Maximum Ratings (cont'd)  
-40 °C ≤ T<sub>j</sub> ≤ 150 °C

#	Parameter	Symbol	Limit Values		Unit	Conditions
			min.	max.		
M12	ESD	–	±4000	–	V	according to EIA/JESD 22-A 114B
			±2000	–	V	U <sub>ZP</sub> , MR, EN, VR, SILA, all other pins
M13	Life Time	t <sub>b</sub>	10000	–	h	ambient temperature range: -40 °C 2% -20 °C 10% 25 °C 24% 60 °C 34% 80 °C 24% 100 °C 5% >120 °C 1%

**Note:** Stresses above the ones listed here may cause permanent damage to the device. Exposure to absolute maximum rating conditions for extended periods may affect device reliability.

Electrical Characteristics

3.2 Functional Range

#	Parameter	Symbol	Limit Values			Unit	Conditions
			min.	typ.	max.		
F1	Supply voltage	$U_{ZP}$	4.5	14.0	18	V	–
			–	–	26.5	V	$t < 5 \text{ min.}$
			–	–	4.5	V	$U_{ST} \leq 0.3 \text{ V};$ Reset = Low; Enable = Low; VR and MR off
F2	Input capacitor	$C_{UZP}$	0.33	3.3	–	$\mu\text{F}$	$T_U = 20 \text{ }^\circ\text{C}$ $U_N = 63 \text{ V}$ Typ. = MKT
F3	Case Temperature	$T_C$	-40	–	125	$^\circ\text{C}$	P-DSO-20-12
F4	Junction Temperature	$T_j$	-40	–	150	$^\circ\text{C}$	life time
			–	–	175	$^\circ\text{C}$	short time <sup>1)</sup>
F5	Thermal resistance junction-ambient	$R_{thja}$	–	40	–	K/W	P-DSO-20-12 minimum footprint
F6	Thermal resistance junction-case	$R_{thjc}$	–	–	2.4	K/W	P-DSO-20-12

1) Parameter may deviate in the temperature range  $T_j = 150 \text{ }^\circ\text{C} \dots 175 \text{ }^\circ\text{C}$   
Total operation time max. 50 h for temperature range  $T_j > 150 \text{ }^\circ\text{C}$

Within the functional range the device works according to the functional description. However parameters may exceed the values given in the Characteristics.

## 4 Block Description and Electrical Characteristics

### 4.1 General

#### Characteristics

$6\text{ V} \leq U_{ZP} \leq 18\text{ V}$ ,  $-40\text{ °C} \leq T_j \leq +150\text{ °C}$ , if not otherwise specified

#	Parameter	Symbol	Limit Values			Unit	Conditions
			min.	typ.	max.		
4.1.1	Power consumption regulator	$I_{UZP}$	–	7	15	mA	$U_{ZP} = 16\text{ V}$ , $I_{UST} = 800\text{ mA}$ , VR on, SILA on, EN, RES1, RES2 = High
4.1.2	Overtemperature protection threshold	$T_{ab}$	150	–	–	°C	$T_j > T_{ab}$

### 4.2 Oscillator

A 16 kHz oscillator is used as time base for the 1 kHz clock. An independent clock supervision circuit supervises the oscillator. If the oscillator clock is missing the error flag is set.

#### Characteristics Internal Oscillator

$6\text{ V} \leq U_{ZP} \leq 18\text{ V}$ ,  $-40\text{ °C} \leq T_j \leq +150\text{ °C}$ , if not otherwise specified

#	Parameter	Symbol	Limit Values			Unit	Conditions
			min.	typ.	max.		
4.2.1	Frequency	$f_{OSZ}$	14.4	16	17.6	kHz	$U_{ZP} \geq 6\text{ V}$ $4.7\text{ V} \leq U_{ZP} < 6\text{ V}$
			13.6	–	18.4		
4.2.2	Clock supervision	$t_{CLUE}$	–	120	–	µs	error if $t_{Low}$ or $t_{High} > t_{CLUE}$
4.2.3	Logic time base	$t_{CLK}$	0.9	1	1.1	ms	Period



**Block Description and Electrical Characteristics**

**4.3 Charge Pump**

The integrated charge pump requires an external capacitor at pin  $U_{CP}$ . The charge pump voltage is typically 15 V. It is internally used for the voltage regulator only. It is only intended for internal function and may not be used for any external loads. The output voltage is short circuit protected against the supply voltage.

**Characteristics Charge Pump**

$6\text{ V} \leq U_{ZP} \leq 18\text{ V}$ ,  $-40\text{ }^{\circ}\text{C} \leq T_j \leq +150\text{ }^{\circ}\text{C}$ , if not otherwise specified

#	Parameter	Symbol	Limit Values			Unit	Conditions
			min.	typ.	max.		
4.3.1	Power up time	$t_{CP}$	–	10	–	ms	$U_{ZP} = 6\text{ V}$ ; $C_{CP} = 68\text{ nF}$ ; Load capacitor to $U = 0.9 \times U_{CPmax}$
4.3.2	Charge pump voltage	$U_{CP}$	–	15	22	V	Regulator on
4.3.3	Frequency	$f_{CP}$	1.4	3.2	–	MHz	–

## Block Description and Electrical Characteristics

### 4.4 Voltage Regulator

The 5 V low drop linear regulator can supply up to 800 mA current. The regulator requires an output capacitor. The linear regulator is equipped with overcurrent protection and its own overtemperature protection. The linear element consists of 2 anti-serial DMOS transistors. In case of low input supply voltage this avoids discharging of the output capacitor.

The output voltage  $U_{ST}$  is supervised for over- and undervoltage.  $U_{ST}$  output has to be connected externally to the sense input  $U_{STS}$ . If over- or undervoltage condition is detected the Reset outputs RES1 and RES2 are logical low. For a detailed description of the reset logic please see [Chapter 4.9](#).

#### Characteristics Voltage Regulator

$6\text{ V} \leq U_{ZP} \leq 18\text{ V}$ ,  $-40\text{ °C} \leq T_j \leq +150\text{ °C}$ , if not otherwise specified

#	Parameter	Symbol	Limit Values			Unit	Conditions
			min.	typ.	max.		
4.4.1	Nominal output voltage	$U_{ST}$	4.95 4.925	5.00 5.00	5.05 5.075	V V	$U_{ZP} = 14\text{ V}$ ; $I_{ST} = 400\text{ mA}$ ; Output capacitor as defined in <a href="#">4.4.11</a> ; on wafer level $T_j = 25\text{ °C}$ P-DSO-20-12
4.4.2	$U_{ST}$ load current	$I_{ST}$	–	–	800	mA	–
4.4.3	Line variation	$\Delta U_{ST}$	–	–	50	mV	$T_j = 25\text{ °C}$ ; $6.0\text{ V} \leq U_{ZP} \leq 18\text{ V}$ ; $I_{ST} = 600\text{ mA}$ ; capacitor as defined in <a href="#">4.4.11</a> ; $dU_Z/dt < 1\text{ V}/\mu\text{s}$

Block Description and Electrical Characteristics

Characteristics Voltage Regulator (cont'd)

$6\text{ V} \leq U_{ZP} \leq 18\text{ V}$ ,  $-40\text{ °C} \leq T_j \leq +150\text{ °C}$ , if not otherwise specified

#	Parameter	Symbol	Limit Values			Unit	Conditions
			min.	typ.	max.		
4.4.4	Load variation	$\Delta U_{ST}$	–	–	50	mV	$T_j = 25\text{ °C}$ ; $U_{ZP} = 14\text{ V}$ ; $0\text{ mA} \leq I_{ST} \leq 800\text{ mA}$ ; capacitor as defined in 4.4.11; $dI_{ST}/dt \leq 1\text{ mA}/\mu\text{s}$
4.4.5	Temperature variation	$\Delta U_{ST}$	–	50	100	mV	$U_{ZP} = 14\text{ V}$ ; $I_{ST} = I_{STmax}$ ; $-40\text{ °C} \leq T_j \leq 150\text{ °C}$ ; capacitor as defined in 4.4.11; for die mounted in a hybrid: $dT_U/dt \leq 10\text{ K/s}$ for P-DSO-20-12: $dT_G/dt \leq 5\text{ K/min}$ .
4.4.6	Long time drift	$\Delta U_{ST}$	–	–	50	mV	$U_{ZP} \leq U_{ZPmax}$ ; $0\text{ mA} \leq I_{ST} \leq I_{STmax}$ ; $-40\text{ °C} \leq T_j \leq 150\text{ °C}$ ; $t_b = 10000\text{ h}$ , see conditions M13.
4.4.7	Overall output voltage tolerance	$U_{ST}$	4.75	5.00	5.25	V	all parameters from 4.4.1 to 4.4.6
4.4.8	Power Supply ripple rejection	$\Delta U_{STss}$	–	–	25	mV	$0\text{ Hz} \leq f_{UST} \leq 10\text{ kHz}$ ; capacitor as defined in 4.4.11; $7\text{ V} \leq U_{ZP} \leq 24\text{ V}$
4.4.9	Series Resistor	$R_{Dson}$	–	–	1.7 2.7	$\Omega$ $\Omega$	$T_j = 25\text{ °C}$ $T_j = 150\text{ °C}$  $U_{CP} > 15\text{ V}$ ; $U_{ZP} = 6\text{ V}$ ; $I_{ST} = 800\text{ mA}$
4.4.10	Maximum output current (output shorted)	$I_K$	0.8	–	1.6	A	$U_{CP} > 15\text{ V}$ ; $U_{ST} = 0\text{ V}$ ; $4.5\text{ V} \leq U_{ZP} \leq 18\text{ V}$
4.4.11	Load capacitor at output $U_{ST}$	$C_{UST}$	3.3	–	150	$\mu\text{F}$	$T_U = 20\text{ °C}$ ; $U_N = 25\text{ V}$ ; Type ETQW Roederstein
		Z	–	4	–	$\Omega$	$f = 100\text{ kHz}$ ; $T_U = 20\text{ °C}$
4.4.12	$U_{ST}$ off voltage	$U_{STRest}$	–	–	400	mV	$I_{ST} = 0\text{ mA}$
4.4.13	Clamping voltage	$U_{ZST}$	5.5	–	7	V	clamping voltage at $I = 100\text{ mA}$

**Block Description and Electrical Characteristics**

**4.5 Enable-Output EN**

The open collector enable output EN informs the system about any error condition. Any error except a detected supply under-voltage will set the EN output Low. Of cause for long under-voltage at the supply line, soon the  $U_{ST}$  output capacitor will be discharged and this will cause  $U_{ST}$  under-voltage and therefore EN Low. The time depends on the load and the output capacitor. The EN is an open collector output. It is short circuit protected to  $U_{ST}$ .

After power up when the first watchdog edges at WD1 a WD2 are detected the Enable output is switched into High state.

**Characteristics EN Output**

$6\text{ V} \leq U_{ZP} \leq 18\text{ V}$ ,  $-40\text{ }^{\circ}\text{C} \leq T_j \leq +150\text{ }^{\circ}\text{C}$ , if not otherwise specified

#	Parameter	Symbol	Limit Values			Unit	Conditions
			min.	typ.	max.		
4.5.1	Output Low voltage	$U_L$	–	–	0.4	V	$I_L \leq 10\text{ mA}$
			–	–	0.2	V	$I_L \leq 1\text{ mA}$
4.5.2	Reverse current	$I_R$	–	–	5	$\mu\text{A}$	$U_{EN} = 5\text{ V}$

## Block Description and Electrical Characteristics

### Power Driver

The TLE 6210/TLE 6211 includes 3 open drain outputs for loads up to 0.5 A: The two drivers VR and MR are intended for (valve and motor) relays, while the SILA/NSILA output is designed for a lamp.

In the TLE 6210 GW the SILA output is available. The output goes low if the supply voltage  $U_{ZP}$  is no longer available – the DMOS is switched on automatically. In the TLE 6211 GW the NSILA has the inverted polarity related to SILA. In bare dice both outputs SILA and NSILA can be used.

### 4.6 Valve Relay Output VR

The valve relay output VR is switched On after the power up reset and valid watchdog signals. The driver has an open drain configuration and can supply up to 500 mA. The output is protected against overtemperature and overcurrent. The output is short circuit protected to  $U_Z$ . The output stage is equipped with its own overtemperature protection. In case of overvoltage at the supply  $U_{ZP}$  the output is switched off. However the output is not protected against overvoltages caused by switching inductive loads. Therefore externally a free wheeling diode is required as shown in the application diagram.

The valve relay output VR is controlled by the internal supervision logic. If any watchdog errors or supply over-voltage is detected or the 5 V regulator is out of range, the VR is switched off (please see also [Table 1](#) on [Page 19](#) and [Table 2](#) on [Page 28](#)).

#### Characteristics Relay Driver Output VR

$6\text{ V} \leq U_{ZP} \leq 18\text{ V}$ ,  $-40\text{ °C} \leq T_j \leq +150\text{ °C}$ , if not otherwise specified

#	Parameter	Sym- bol	Limit Values			Unit	Conditions
			min.	typ.	max.		
4.6.1	Saturation Voltage	$U_{DS}$	–	–	1.2	V	$R_{last} \geq 35\ \Omega$ ; $I_L \leq 0.5\text{ A}$ ; $6\text{ V} \leq U_{ZP} \leq 16\text{ V}$
4.6.2	On state resistance	$R_{DSon}$	–	–	2.4	$\Omega$	$T_j = 150\text{ °C}$ ; $I_L = 0.5\text{ A}$ ; $U_{ZP} = 6\text{ V}$
4.6.3	Overload detection current	$I_K$	500	–	–	mA	–
4.6.4	Output leakage current	$I_R$	–	–	0.5 2	mA mA	$U_A \leq 16\text{ V}$ $16\text{ V} < U_A \leq 60\text{ V}$
4.6.5	Overtemperature shutdown threshold	$T_K$	150	–	–	°C	–

Block Description and Electrical Characteristics

### 4.7 Motor Relay Driver

The motor relay driver MR is controlled by the MRA input signal and the internal control logic. A logic High at the MRA input switches the MR low side switch on, a logic Low signal switches it off. However the supervision logic overrules the MRA input condition. Please see also [Table 1](#) on [Page 19](#) and [Table 2](#) on [Page 28](#).

The output is an open collector output and can sink up to 500 mA. It is protected against overtemperature and overcurrent and short circuit prove to  $U_Z$ . Even the output is switched off by the supervision logic at  $U_{ZP}$  overvoltage externally a free wheeling diode is required to protect the output against switching off inductive loads.

#### Characteristics Relay Driver Output MR

$6\text{ V} \leq U_{ZP} \leq 18\text{ V}$ ,  $-40\text{ °C} \leq T_j \leq +150\text{ °C}$ , if not otherwise specified

#	Parameter	Sym- bol	Limit Values			Unit	Conditions
			min.	typ.	max.		
4.7.1	Saturation Voltage	$U_{DS}$	–	–	1.2	V	$R_{last} \geq 35\ \Omega$ ; $I_L \leq 0.5\text{ A}$ ; $6\text{ V} \leq U_{ZP} \leq 16\text{ V}$
4.7.2	On state resistance	$R_{DSon}$	–	–	2.4	$\Omega$	$T_j = 150\text{ °C}$ ; $I_L = 0.5\text{ A}$ ; $U_{ZP} = 6\text{ V}$
4.7.3	Overload detection current	$I_K$	500	–	–	mA	–
4.7.4	Output leakage current	$I_R$	–	–	0.5 2	mA mA	$U_A \leq 16\text{ V}$ $16\text{ V} < U_A \leq 60\text{ V}$
4.7.5	Overtemperature shutdown threshold	$T_K$	150	–	–	$^{\circ}\text{C}$	–

Block Description and Electrical Characteristics

4.7.1 Control Input MRA

The logic inputs MRA expect TTL-type signals from a  $\mu$ -controller with 5 V I/Os. An integrated pull-up resistor ensures that an open input is read High.

Characteristics Control Inputs MRA

$6\text{ V} \leq U_{ZP} \leq 18\text{ V}$ ,  $-40\text{ }^\circ\text{C} \leq T_j \leq +150\text{ }^\circ\text{C}$ , if not otherwise specified

#	Parameter	Sym- bol	Limit Values			Unit	Conditions
			min.	typ.	max.		
4.7.6	Internal pull-up resistor to $U_{ST}$	$R_{WD}$	10	20	40	$k\Omega$	$0\text{ V} \leq U_E \leq U_{ST} + 0.3\text{ V}$
4.7.7	Input voltage Low	$U_L$	-0.3	–	1.0	V	–
4.7.8	Input voltage High	$U_H$	2.0	–	$U_{ST} + 1.0$	V	–
4.7.9	Input current	$I_H$	–	–	5	$\mu\text{A}$	$U_E = U_{ST}$
			–	–	1.0	$\text{mA}$	$U_{ST} < U_E \leq U_{ST} + 1\text{ V}$

Block Description and Electrical Characteristics

### 4.8 Error Lamp Output SILA and Lamp Relay Output NSILA

The SILA output is a 300 mA open collector output. It is available in the TLE 6210 G. SILA is a self-on output: It is switched on if the supply voltage is missing. The TLE 6211 G is equipped with the logically inverted NSILA output. NSILA is a 30 mA open collector output. It is intended to drive the lamp relay. In the dice version TLE 6211 C both outputs can be used.

Both SILA and NSILA are intended to control a warning lamp. The output is controlled by the internal supervision logic and control signal at the SIA pin.

A logic High at the SIA input switches SILA off and NSILA on.

The supervision logic will switch on SILA if a watchdog timing violation is detected or the output voltage  $U_{ST}$  is out of range. [Table 1 on Page 19](#) and [Table 2 on Page 28](#) give an overview on the different errors.

The SILA output is equipped with its own overtemperature protection.

#### Characteristics Lamp Driver Output SILA

$6\text{ V} \leq U_{ZP} \leq 18\text{ V}$ ,  $-40\text{ °C} \leq T_j \leq +150\text{ °C}$ , if not otherwise specified

#	Parameter	Symbol	Limit Values			Unit	Conditions
			min.	typ.	max.		
4.8.1	Saturation voltage	$U_{SILA}$	–	–	2.5	V	$I = 300\text{ mA}$ ; $U_{ZP} \geq 6\text{ V}$
			–	–	2.5		$I = 300\text{ mA}$ ; $U_{ZP} = 0\text{ V}$
4.8.2	Overload detection current	$I_K$	300	–	–	mA	–
4.8.3	Output leakage current	$I_R$	–	–	0.1	mA	$U_{SILA} \leq 16\text{ V}$
			–	–	4	mA	$16\text{ V} < U_{SILA} < 42\text{ V}$
4.8.4	Threshold voltage for automatic ON	$U_{ZP}$	1	–	4.7	V	$U_{SILA} \leq 2.5\text{ V}$ ; $I = 300\text{ mA}$
4.8.5	Overtemperature shutdown threshold	$T_K$	150	–	–	°C	$U_{ZP} \geq 6\text{ V}$



## Block Description and Electrical Characteristics

### Characteristics Lamp-Relay Driver Output NSILA

$6\text{ V} \leq U_{ZP} \leq 18\text{ V}$ ,  $-40\text{ °C} \leq T_j \leq +150\text{ °C}$ , if not otherwise specified

#	Parameter	Symbol	Limit Values			Unit	Conditions
			min.	typ.	max.		
4.8.6	On state resistance	$R_{DSon}$	–	–	33	$\Omega$	$T_j = 150\text{ °C}$ ; $I = 30\text{ mA}$ ; $U_{ZP} \geq 7\text{ V}$
4.8.7	Overload detection current	$I_K$	30	–	–	mA	–
4.8.8	Output leakage current	$I_R$	–	–	10	$\mu\text{A}$	$U_{NSILA} \leq 42\text{ V}$

#### 4.8.1 Control Input SIA

The logic inputs SIA expect TTL-type signals from a  $\mu$ -controller with 5 V I/Os. An integrated pull-up resistor ensures that an open input is read High.

### Characteristics Control Inputs SIA

$6\text{ V} \leq U_{ZP} \leq 18\text{ V}$ ,  $-40\text{ °C} \leq T_j \leq +150\text{ °C}$ , if not otherwise specified

#	Parameter	Symbol	Limit Values			Unit	Conditions
			min.	typ.	max.		
4.8.9	Internal pull-up resistor to $U_{ST}$	$R_{WD}$	10	20	40	k $\Omega$	$0\text{ V} \leq U_E \leq U_{ST} + 0.3\text{ V}$
4.8.10	Input voltage Low	$U_L$	-0.3	–	1.0	V	–
4.8.11	Input voltage High	$U_H$	2.0	–	$U_{ST} + 1.0$	V	–
4.8.12	Input current	$I_H$	–	–	5	$\mu\text{A}$	$U_E = U_{ST}$
			–	–	1.0	mA	$U_{ST} < U_E \leq U_{ST} + 1\text{ V}$

---

## Block Description and Electrical Characteristics

### Supervision

The TLE 6210 and TLE 6211 are equipped with a complex supervision logic. The input voltage and the regulator output voltage is supervised. In addition two  $\mu$ -controller are supervised by independent watchdog circuits.

### 4.9 Overvoltage and Undervoltage

Both the supply voltage  $U_{ZP}$  and the output voltage  $U_{ST}$  are supervised for over- and undervoltage.

In case any undervoltage or overvoltage condition at  $U_{ST}$  or  $U_{ZP}$  is detected, the reset outputs RES1 and RES2 are switched to low state. RES1 and RES2 are not controlled by the watchdog logic.

To supervise the output voltage  $U_{ST}$  an independent bandgap from the reference bandgap is used.

The reset outputs RES1 and RES2 are together controlled by the  $U_{ST}$  reset logic and the supply undervoltage lockout (UVLO) and overvoltage lockout (OVLO).

A logic High at the RES1 and RES2 indicates normal operation. The outputs are open collector type outputs with integrated pull-up resistors to  $U_{ST}$ . Even when the  $U_{ST}$  voltage drops, the reset outputs RES1 and RES2 remain low ( $< 0.4$  V).

Both undervoltage and overvoltage detection of  $U_{ST}$  and  $U_{ZP}$  use a voltage hysteresis to avoid any reset toggling.

#### Undervoltage and Overvoltage Detection $U_{ST}$

The  $U_{ST}$  output voltage has to be externally connected to the  $U_{STs}$  sense input.

To be able to detect also wrong output voltages caused by a malfunction of the related bandgap reference for supervision an independent bandgap is used.

As soon as any reset condition is detected the RES1 and RES2 go low.

#### 4.9.1 Undervoltage Lockout (UVLO) and Overvoltage Lockout (OVLO)

The supply voltage  $U_{ZP}$  is supervised as well. If the voltage rises above the upper threshold value of 19.5 V reset is asserted. When an undervoltage occurs, after some time the output voltage will drop below the reset threshold and a reset is asserted. The undervoltage lockout is only valid during power up.

Both the OVLO and the UVLO threshold use a hysteresis to avoid reset glitches. In addition the OVLO is digitally filtered. Overvoltage below 2 to 3 clock cycles (equals typical 2  $\mu$ s or 3  $\mu$ s) are neglected to avoid resetting the system when any inductive load is switched off.

**Block Description and Electrical Characteristics**

When the undervoltage condition at  $U_{ST}$  or  $U_{ZP}$  is no longer detected a reset reaction time of typical 52 ms (52 clock cycles) is started. After this time the reset signal is set high.

**Table 1 Truth Table Overvoltage and Undervoltage Supervision**

The table assumes that no other error is detected, especially no watchdog failure and no clock failure.

Supply voltage $U_{ZP}$	Regulator Voltage $U_{ST}$	SILA	NSILA	MR	VR	EN	RES 1 RES 2	Regulator
ok	ok	= SIA	= not SIA	= not MRA	L	Z	H	ON
ok	under-voltage	L	Z	Z	Z	L	L	ON
normal	over-voltage	L	Z	Z	Z	L	H	ON
under-voltage	under-voltage	L	Z	Z	Z	Z*	L	OFF
under-voltage	ok	= SIA	= not SIA	not MRA	L	H	H	ON
over-voltage	x	= L	Z	Z	Z	Z*	L	OFF

Z: high impedance

\* In the application the voltage is undefined as regulator is off

### 4.9.2 Under- and Overvoltage Reset Behavior

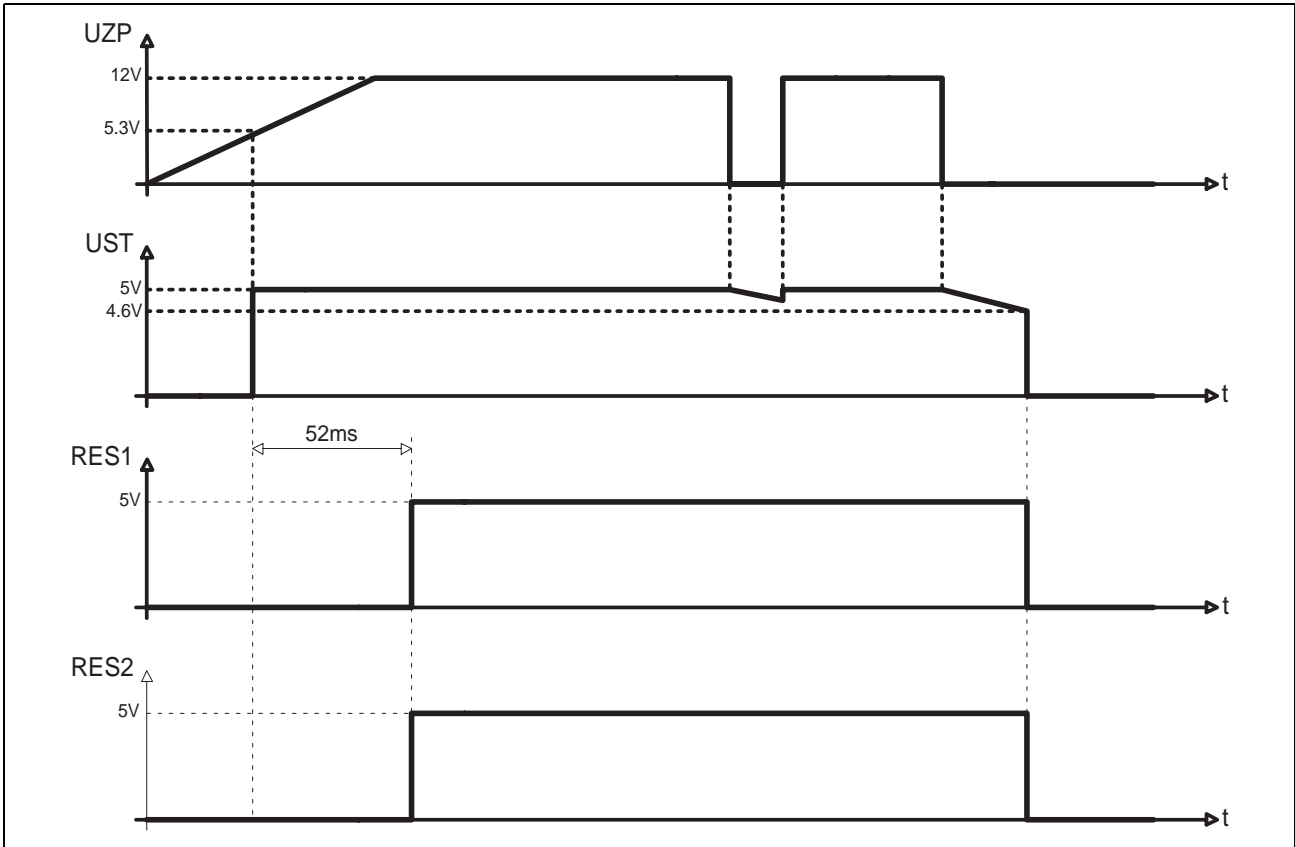

Figure 4

#### Characteristics Supervision of $U_{ZP}$ , $U_{ST}$

$6\text{ V} \leq U_{ZP} \leq 18\text{ V}$ ,  $-40\text{ }^\circ\text{C} \leq T_j \leq +150\text{ }^\circ\text{C}$ , if not otherwise specified

#	Parameter	Symbol	Limit Values			Unit	Conditions
			min.	typ.	max.		

#### $U_{ZP}$ -Undervoltage

4.9.1	$U_{ZP}$ undervoltage threshold	$U_{ZPU}$	5.2	5.3	5.4	V	$U_{ST}$ off
4.9.2	$U_{ZP}$ undervoltage hysteresis	$U_H$	20	–	50	mV	$U_{ZPU(ON)} = U_{ZPU(OFF)} + U_H^{1)}$

#### $U_{ZP}$ -Overvoltage

4.9.3	$U_{ZP}$ overvoltage threshold	$U_{ZUE}$	18.75	19.5	20.25	V	Outputs NSILA, VR, MR, $U_{ST}$ off
-------	--------------------------------	-----------	-------	------	-------	---	-------------------------------------

## Block Description and Electrical Characteristics

### Characteristics Supervision of $U_{ZP}$ , $U_{ST}$ (cont'd)

$6\text{ V} \leq U_{ZP} \leq 18\text{ V}$ ,  $-40\text{ °C} \leq T_j \leq +150\text{ °C}$ , if not otherwise specified

#	Parameter	Symbol	Limit Values			Unit	Conditions
			min.	typ.	max.		
4.9.4	$U_{ZP}$ overvoltage hysteresis	$U_H$	0.5	–	1.0	V	$U_H = U_{ZUE(on)} - U_{ZUE(off)}$
4.9.5	$U_{ZP}$ overvoltage filter	$t_{on}$	2 1.8	– –	3 3.4	$\times t_{CLK}$ ms	$U_{ZP} \geq$ overvoltage threshold
		$t_{off}$	2 1.8	– –	3 3.4	$\times t_{CLK}$ ms	$U_{ZP} <$ overvoltage threshold

### $U_{ST}$ -Undervoltage

4.9.6	$U_{ST}$ undervoltage threshold	$U_{STU}$	4.5	4.6	4.7	V	RES1, RES2 = low
4.9.7	$U_{ST}$ undervoltage hysteresis	$U_H$	20	–	50	mV	$U_{STU(on)} = U_{STU(off)} + U_H^{1)}$

### $U_{ST}$ -Overvoltage

4.9.8	$U_{ST}$ overvoltage threshold	$U_{STUE}$	5.3	5.4	5.5	V	Error flag is set
4.9.9	$U_{ST}$ overvoltage hysteresis	$U_H$	20	–	50	mV	$U_{STUE(ON)} = U_{STUE(off)} - U_H^{1)}$
4.9.10	$U_{STS}$ input current	$I_{STS}$	0.94	1.5	2.2	mA	$U_{STS} = 6\text{ V}$

### Reset timing

4.9.11	Reset delay time	$t_{RH}$	– 46.35	52 52	– 58.85	$\times t_{CLK}$ ms	$U_{ZP} \geq 5.4\text{ V}$ $U_{ST} \geq 4.75\text{ V}$
--------	------------------	----------	------------	----------	------------	------------------------	---

1) Hysteresis guaranteed by design.

Block Description and Electrical Characteristics

#### 4.10 Reset Outputs RES1, RES2

The two reset outputs RES1 and RES2 are open collector outputs with integrated pull-up resistor of typical 10 kΩ to  $U_{ST}$ . Both outputs are protected against short circuits to  $U_{ST}$ .

##### Characteristics RES1 and RES2

$6\text{ V} \leq U_{ZP} \leq 18\text{ V}$ ,  $-40\text{ °C} \leq T_j \leq +150\text{ °C}$ , if not otherwise specified

#	Parameter	Sym- bol	Limit Values			Unit	Conditions
			min.	typ.	max.		
4.10.1	Output low voltage	$U_L$	–	–	0.4	V	$I_L = 0.8\text{ mA}$ ; $U_{ST} = 1.8\text{ V}$ $I_L = 2\text{ mA}$ ; $U_{ST} = 4.5\text{ V}$ $1.8\text{ V} \leq U_{ST} \leq 4.5\text{ V}$
			–	–	0.4	V	
4.10.2	Output high voltage	$U_H$	$U_{ST} - 0.1$	–	$U_{ST}$	V	$R_L \geq 10\text{ M}\Omega$
4.10.3	Internal pull-up resistor to $U_{ST}$	$R_{RES}$	5	10	20	kΩ	$0\text{ V} \leq U_A \leq U_{ST} + 0.3\text{ V}$

### 4.11 Watchdog

To supervise the operation of 2  $\mu$ -processors watchdog logic for two input signals is integrated. The logic expects at each WD1 and WD2 rectangular signals with 10 ms high and 10 ms low time. Deviations from the expected time are counted as errors and influence the output signals.

A digital filter suppresses noise or pulses below 3 clock cycles (typ. 3 ms).

The detection circuit is described in [Figure 12](#).

After power up and 1 or 2 valid watchdog edges the WD logic enables the output Drivers.

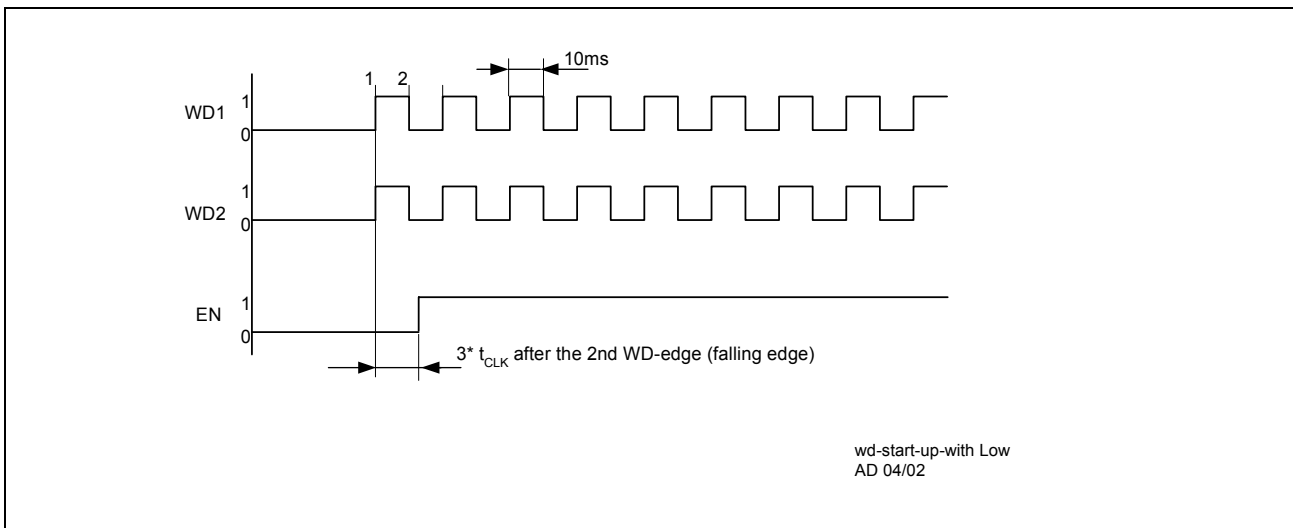

**Figure 5** Enable output EN after correct watchdog signals at WD1 and WD2 are present; WD1 and WD2 start with logic Low

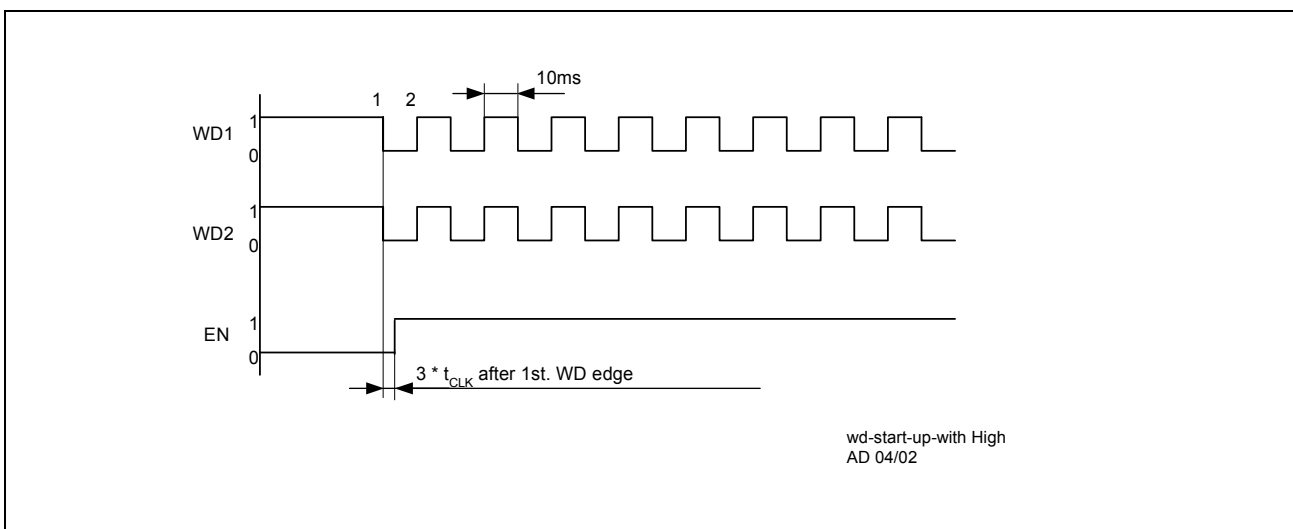

**Figure 6** Enable output EN after correct watchdog signals at WD1 and WD2 are present; WD1 and WD2 start with logic High

## Block Description and Electrical Characteristics

The logic expects the time between two clock edges between 3 and 15 clock-cycles. If this window is not met, the outputs VR, MR and NSILA are switched off, SILA is switched on and the enable output goes low.

An internal counter ( see [Figure 12](#)) includes a 4 bit counter. Each time the value 15 is reached a dominant counter reset signal is generated at the output "=15". This pulse is generated continuously at

$$t = (15+3) T1 + n * (16*T1)$$

after the last valid watchdog pulse was detected.

When internal resets and watchdog edges occur at the same time, the internal reset is dominant.

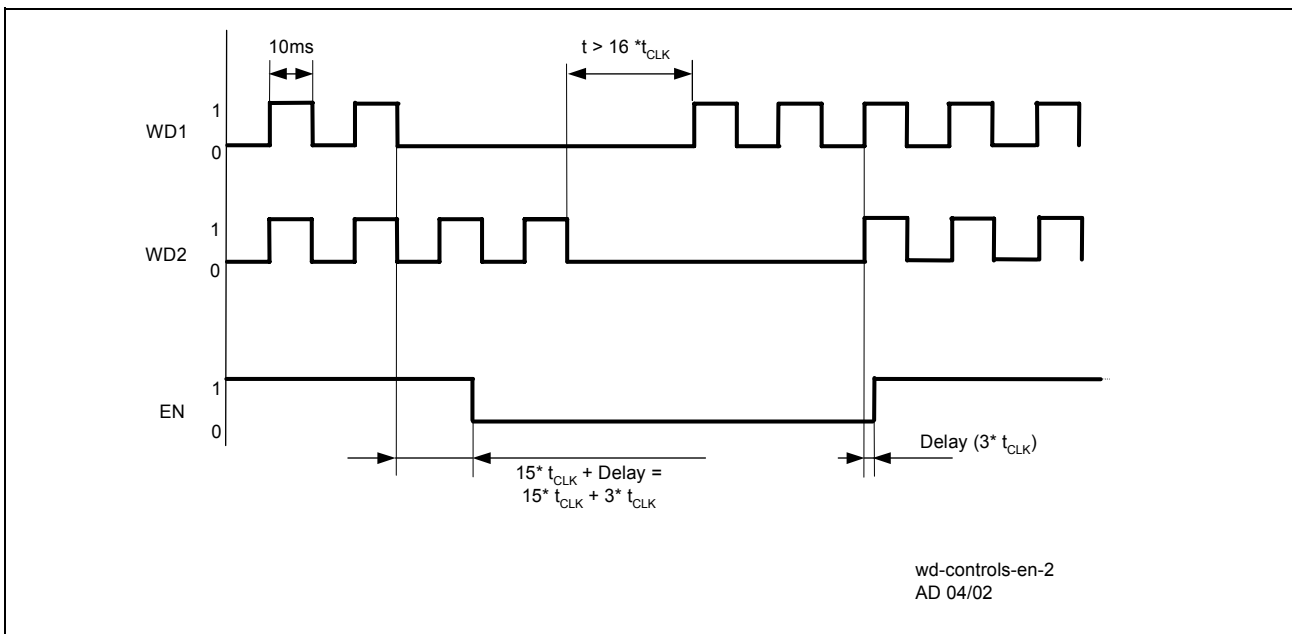

**Figure 7** Missing watchdog signals cause EN low



Block Description and Electrical Characteristics

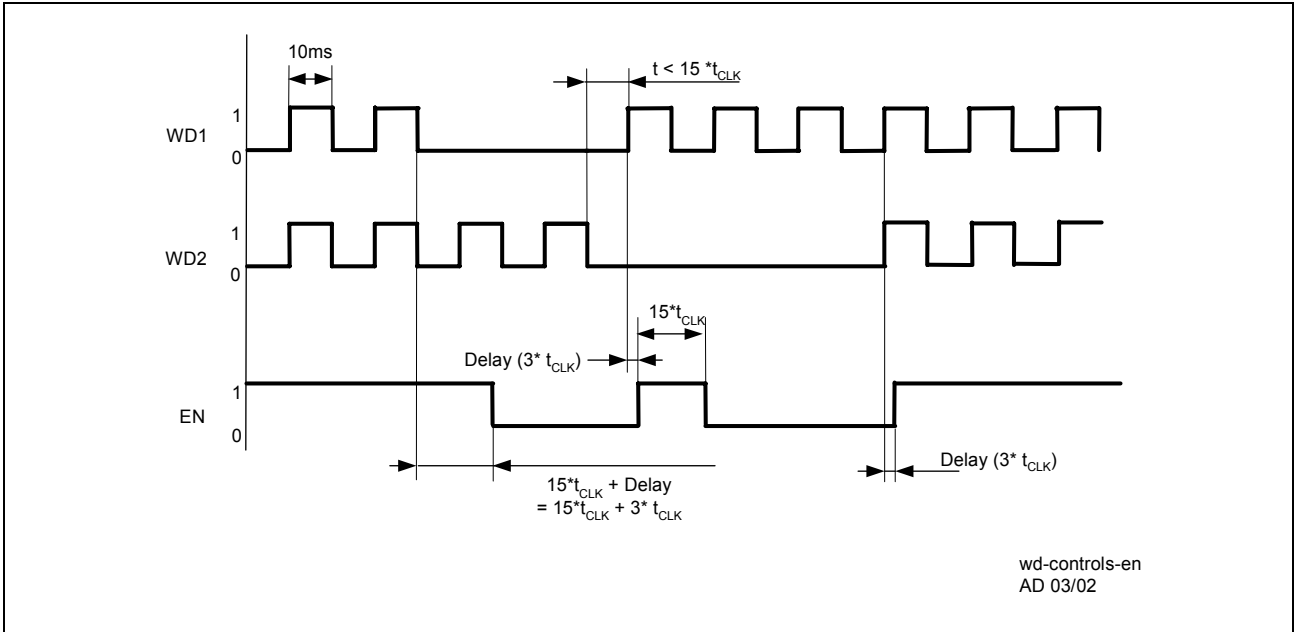

**Figure 8** Missing watchdog signals cause EN low

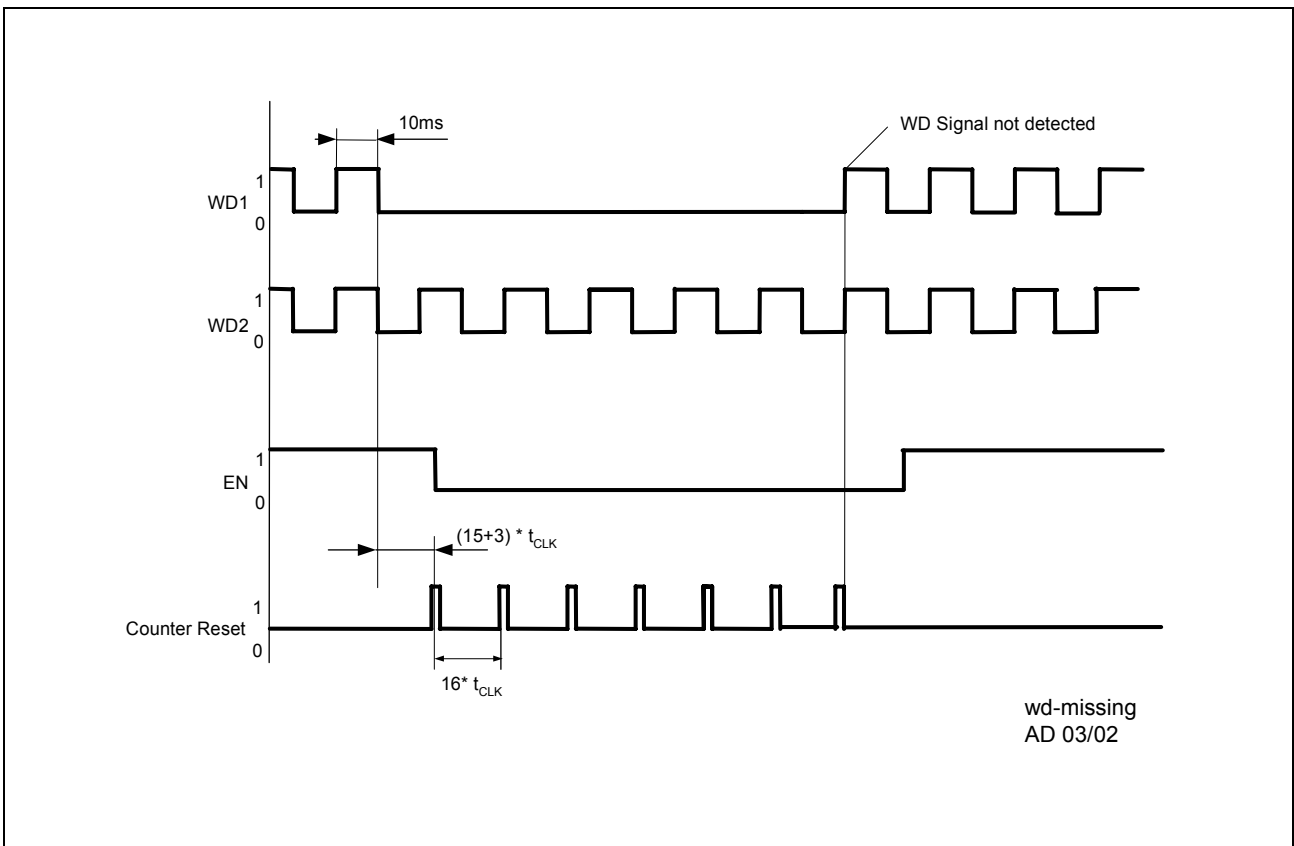

**Figure 9** Timing diagram - any watchdog signal missing causes a High signal at the output "=15" (Counter reset). This signal sets back the logic

### Block Description and Electrical Characteristics

Any watchdog high or low time above 15 ms influences the enable (EN) and the VR output. If the time after the last watchdog edge exceeds 120 clock cycles - typical 120 ms - an error flag is set. This flag can only be removed by powering down the IC.

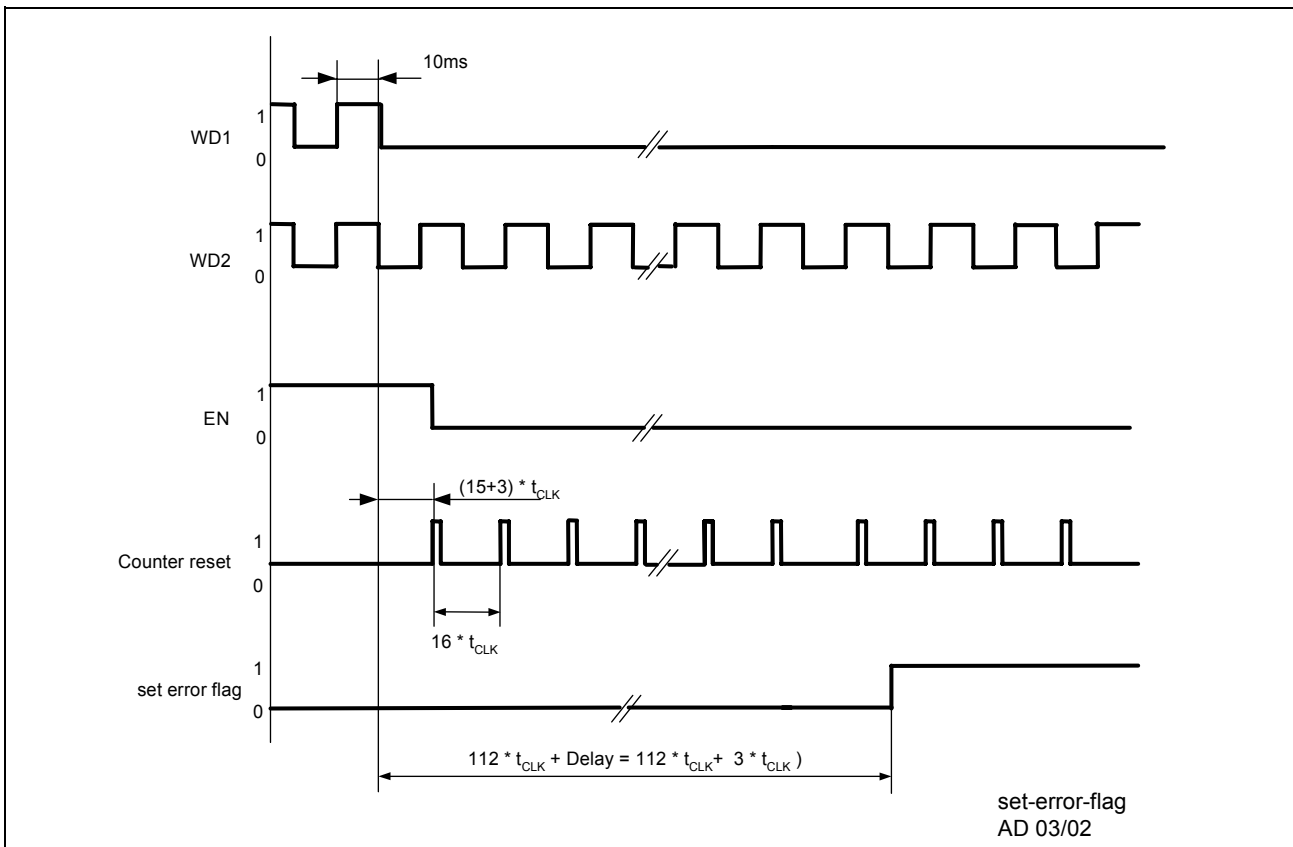

**Figure 10** Missing watchdog signals for more than  $120 * t_{CLK}$  (typ. 120ms) sets the failure register

An integrated pull-up resistor to  $U_{ST}$  in the WD1 and WD2 inputs ensures to detect a permanent logic High in case the input is open.

## Block Description and Electrical Characteristics

### Characteristics WD1, WD2

$6\text{ V} \leq U_{ZP} \leq 18\text{ V}$ ,  $-40\text{ }^{\circ}\text{C} \leq T_j \leq +150\text{ }^{\circ}\text{C}$ , if not otherwise specified

#	Parameter	Symbol	Limit Values			Unit	Conditions
			min.	typ.	max.		
4.11.1	Internal pullup resistor to $U_{ST}$	$R_{WD}$	10	20	40	k $\Omega$	$0\text{ V} \leq U_E \leq U_{ST} + 0.3\text{ V}$
4.11.2	Input voltage Low	$U_L$	-0.3	–	1.0	V	–
4.11.3	Input voltage High	$U_H$	2.0	–	$U_{ST} + 1.0$	V	–
4.11.4	Input current	$I_H$	–	–	5	$\mu\text{A}$	$U_E = U_{ST}$
			–	–	1.0	mA	$U_{ST} < U_E \leq U_{ST} + 1\text{ V}$

### Characteristics Watchdog

$6\text{ V} \leq U_{ZP} \leq 18\text{ V}$ ,  $-40\text{ }^{\circ}\text{C} \leq T_j \leq +150\text{ }^{\circ}\text{C}$ , if not otherwise specified

#	Parameter	Symbol	Limit Values			Unit	Conditions
			min.	typ.	max.		
4.11.5	Release reaction time	$t_{ON}$	1	–	2	$\times t_{CLK}$	Number of valid Watchdog input clock edges
4.11.6	Closed window time	$t_{pulse}$	–	3	–	$\times t_{CLK}$	The distance between clock edges is at least $t_{pulse}$  equals: periodically pulse
			2.25	3	3.3	ms	
			1.8	3	3.3	ms	
4.11.7	Open window time	$t_{VR}$	–	15	–	$\times t_{CLK}$	if the edge distance $\Delta t > t_{VR}$ , VR is switched off
			13.5	15	17.6	ms	equals
4.11.8	Error flag detection	$t_{FSP}$	–	120	–	$\times t_{CLK}$	if $\Delta t > t_{FSP}$ , the error flag is set.
			108	120	132	ms	equals

**Block Description and Electrical Characteristics**

**4.11.1 Watchdog Logic**

Table 2 and Figure 11 show the watchdog logic. figure 12 shows the logic implementation

Watchdog WD1, WD2 Time between Edges	Clock	SILA	NSILA	MR	VR	EN	RES1/2	Error Flag
ok	ok	= SIA	= not SIA	= not MRA	L	Z	H	L
$< 3 * t_{CLK}$	ok	L	Z	Z	Z	L	H	L
$> 15 * t_{CLK}$	ok	L	Z	Z	Z	L	H	L
$> 120 * t_{CLK}$	ok	L	Z	Z	Z	L	H	H
ok	error	L	Z	Z	Z	L	H	H

**Table 2 Watchdog and Clock Supervision Truth Table**

The table assumes that no other error is detected, especially no undervoltage or overvoltage at the supply and regulator output.

Z: High impedance

Block Description and Electrical Characteristics

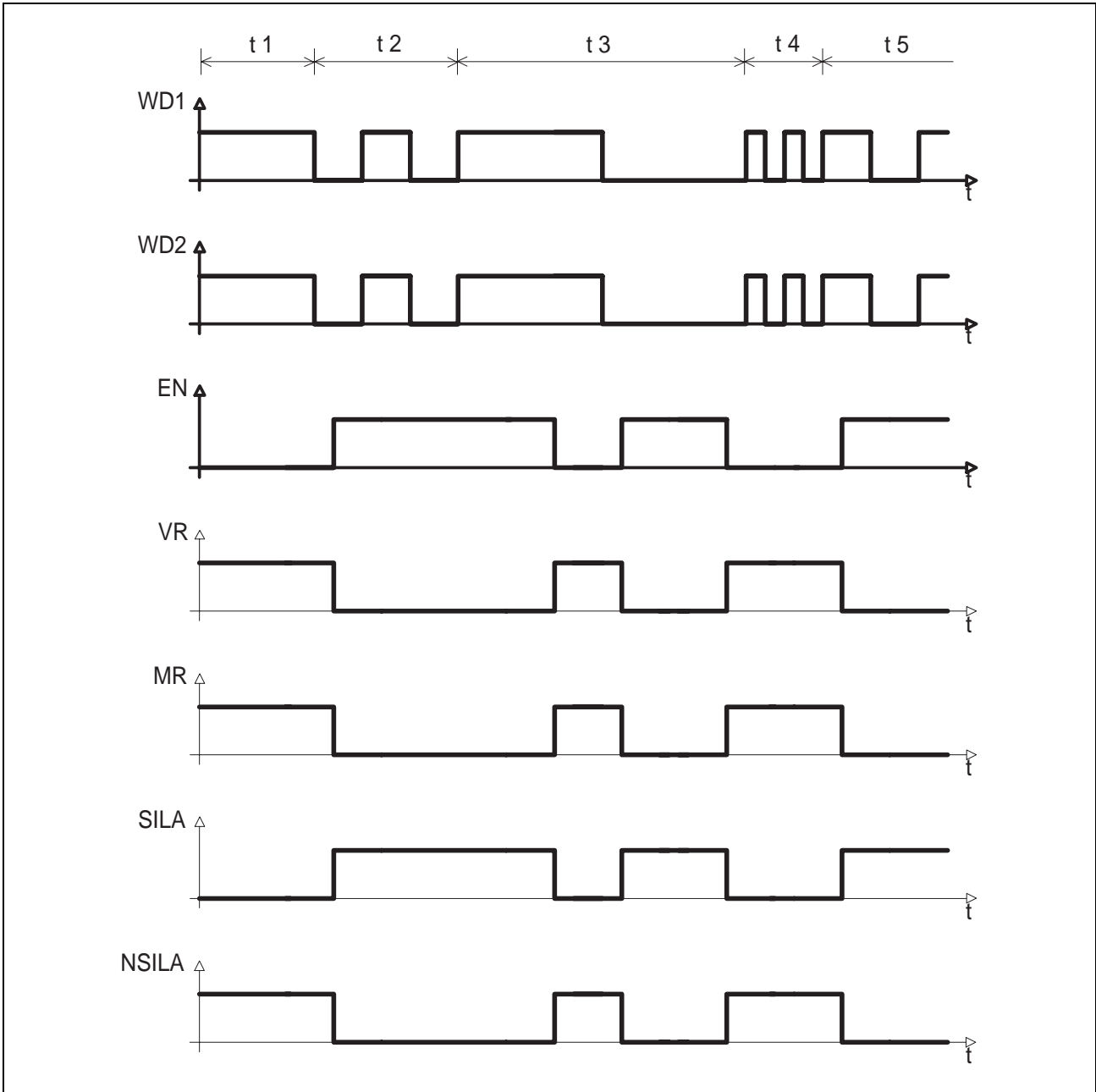

**Figure 11 Watchdog Violation Reaction**

- $t_1$ : No watchdog signals at WD1 or WD2
- $t_2$ : Normal operation. EN is going high after the first watchdog edges at WD1 and WD2 are detected.
- $t_3$ : Watchdog open window time exceeded: but below  $120 \cdot t_{CLK}$  (typ. 120 ms). Error Flag is not set.
- $t_4$ : Watchdog time too short (below closed window time)
- $t_5$ : Normal operation

Block Description and Electrical Characteristics

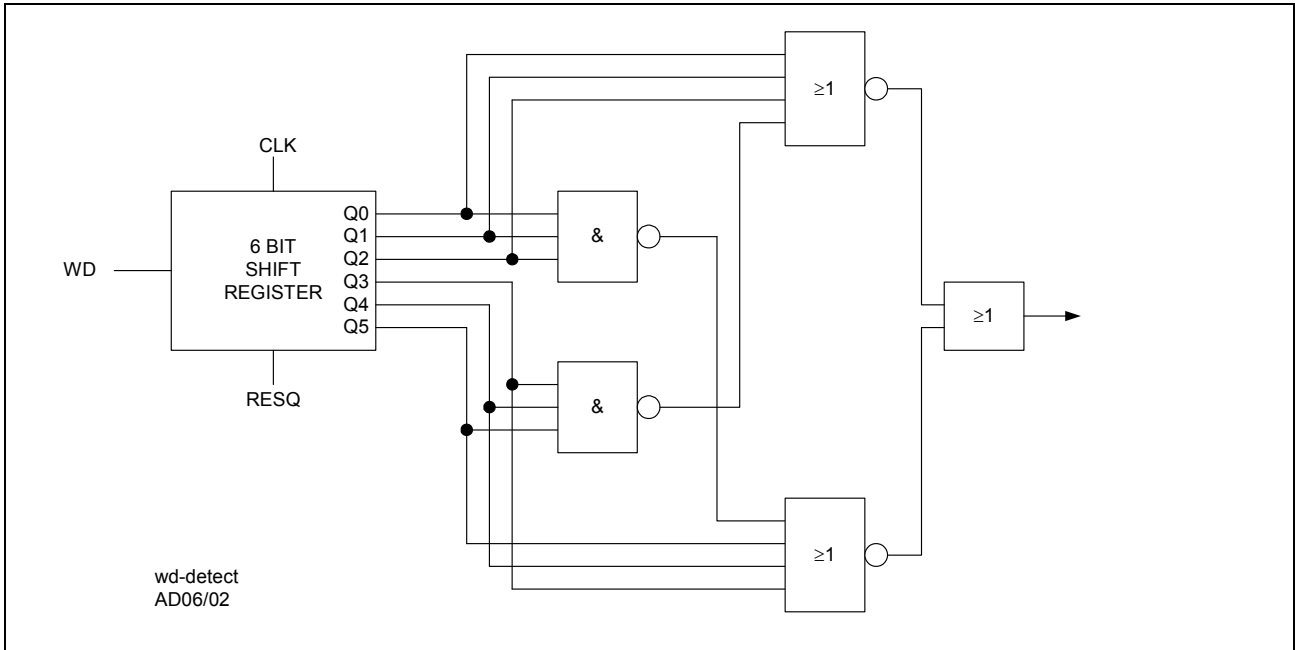

Figure 12 Logic Diagram: Detection of Watchdog Edges.

The watchdog signal is clocked through the shift register. The output condition of the edge detection circuit above is true for register state 111000 and 000111. 3 clks after the rising edge or falling edge of WD<sub>x</sub> the logic below will get a pulse of 1 clk length.

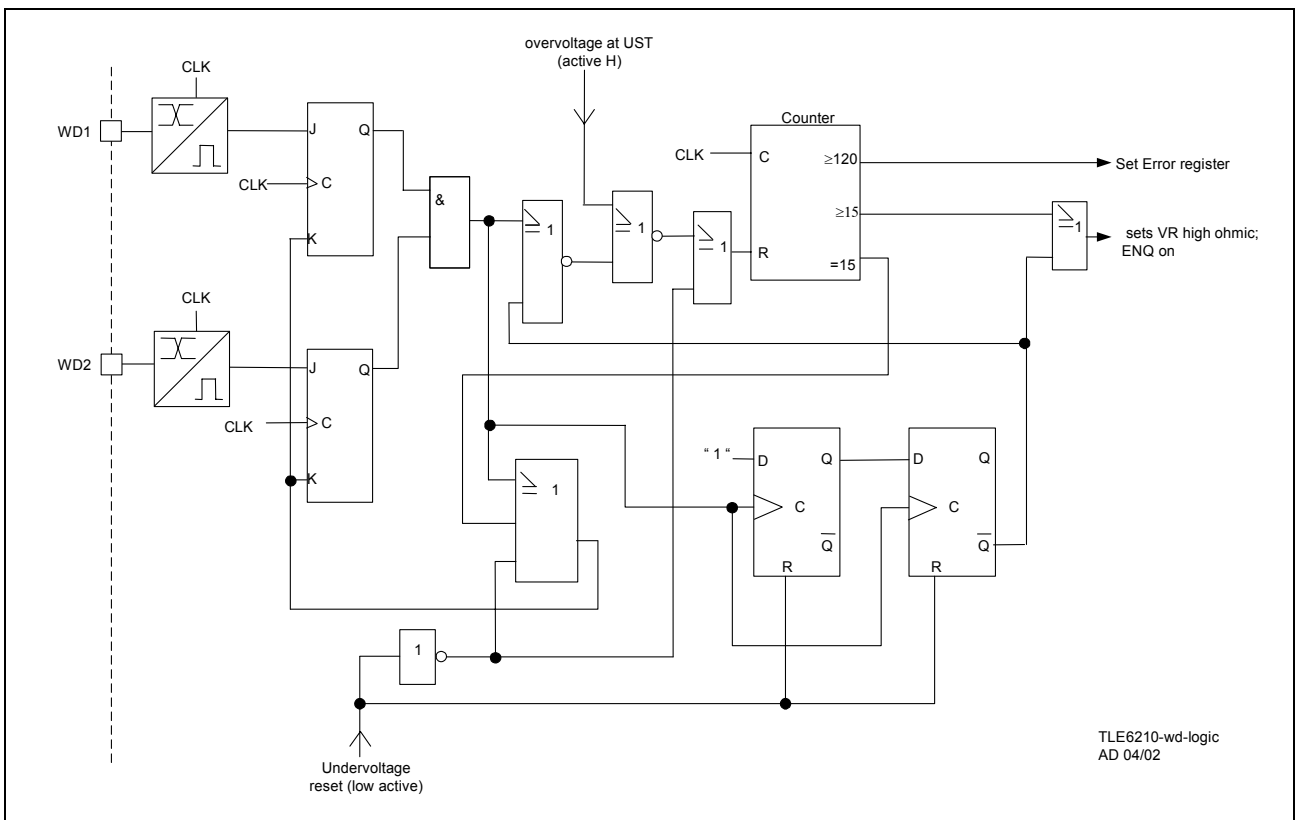
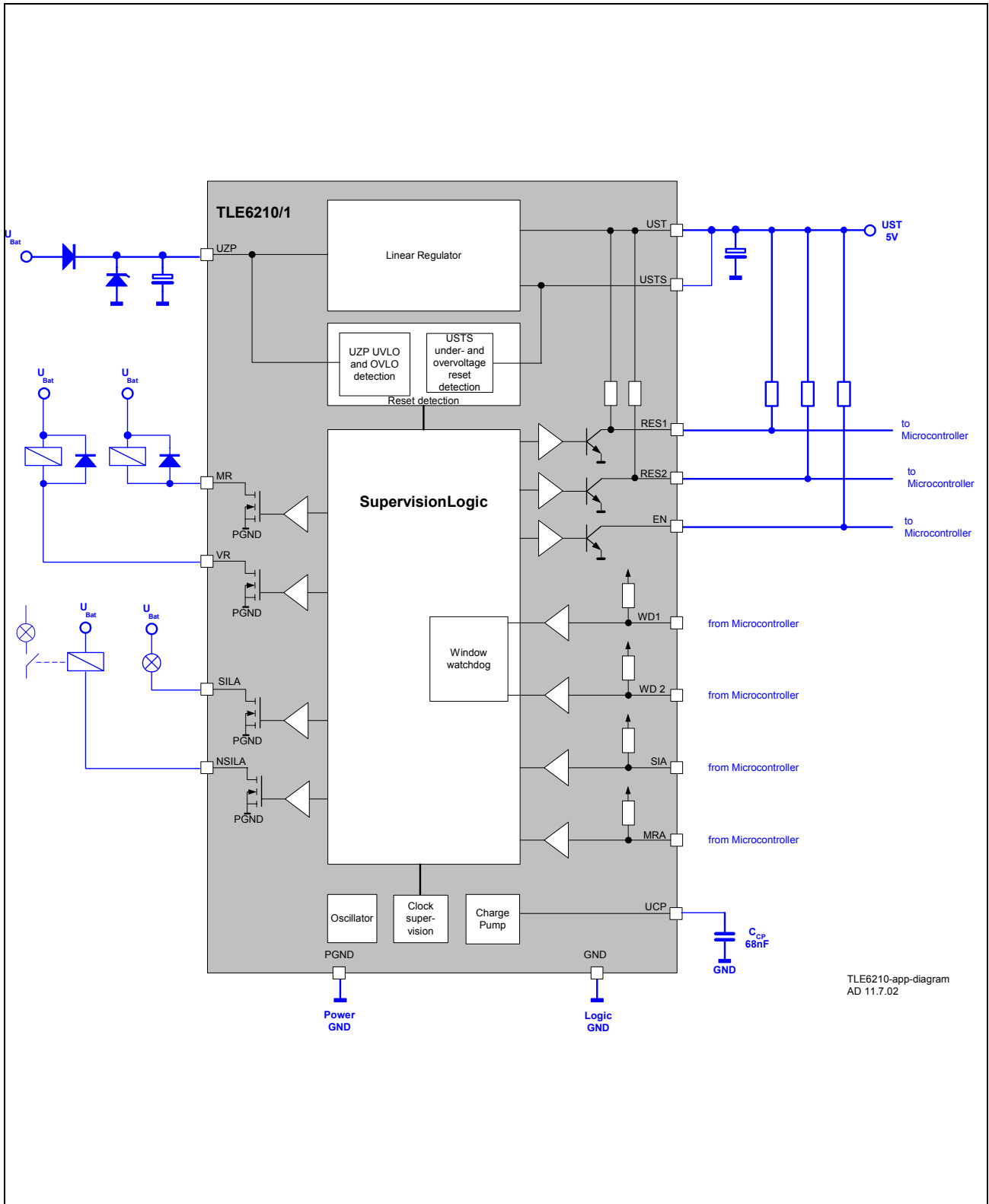

Figure 13 Block Diagram Watchdog Logic

## 5 Application Diagram



TLE6210-app-diagram  
AD 11.7.02

Figure 14 Application Diagram

## 6 Package Outlines

### P-DSO-20-12 (Plastic Dual Small Outline Package)

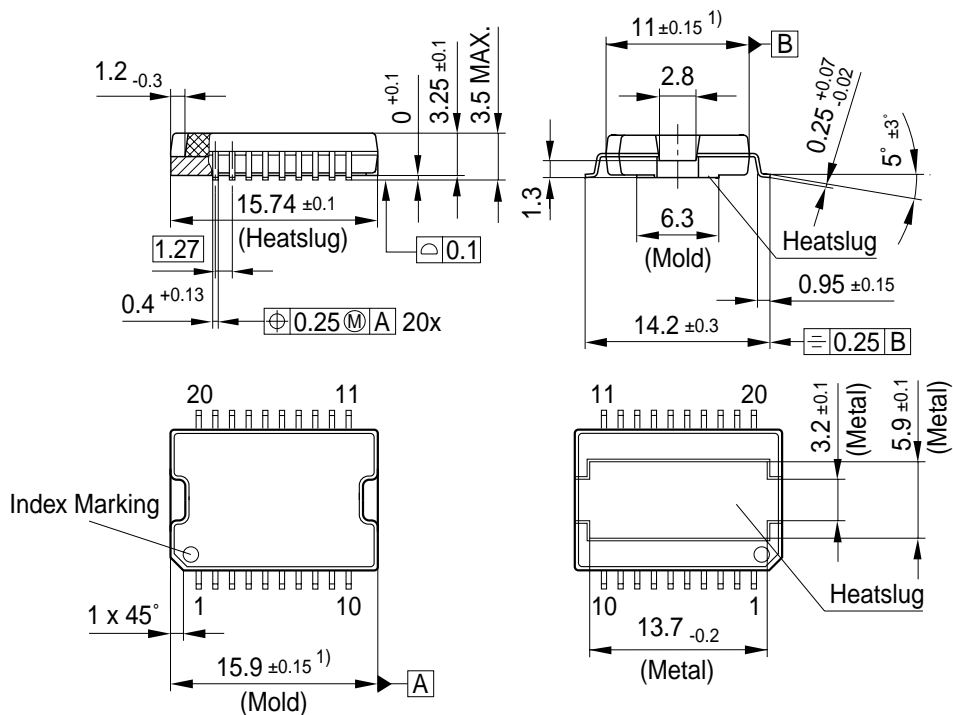

<sup>1)</sup> Does not include plastic or metal protrusion of 0.15 max. per side

GPS05791

### Sorts of Packing

Package outlines for tubes, trays etc. are contained in our Data Book "Package Information".

SMD = Surface Mounted Device

Dimensions in mm



Revision History

Version	Date	Major Changes																																										
V0.0	2002-08	<p>Advanced Information Data Sheet TLE 6210, TLE 6211</p> <p>Device is a replacement of the TLE 5200/TLE 5201 with the following deviations from the specification from 1998-01-21.</p> <p>Devices are only available in the P-DSO-20-12 package or as bare dice</p> <p>The data sheet structure was changed and some chapters were moved. Parameter reference numbers are changed now:</p> <table border="0"> <thead> <tr> <th></th> <th>TLE 5200/01</th> <th>TLE 6210/11</th> </tr> </thead> <tbody> <tr> <td>• Control input SIA</td> <td>1.x</td> <td>4.8.x</td> </tr> <tr> <td>• Control input MRA</td> <td>1.x</td> <td>4.7.x</td> </tr> <tr> <td>• Enable</td> <td>2.x</td> <td>4.5.x</td> </tr> <tr> <td>• Reset outputs</td> <td>3.x</td> <td>4.10.x</td> </tr> <tr> <td>• SILA/NSILA</td> <td>4.x</td> <td>4.8.x</td> </tr> <tr> <td>• VR</td> <td>5.x</td> <td>4.6.x</td> </tr> <tr> <td>• MR</td> <td>5.x</td> <td>4.7.x</td> </tr> <tr> <td>• Voltage supervision</td> <td>6.x</td> <td>4.9.x</td> </tr> <tr> <td>• Oscillator</td> <td>7.x</td> <td>4.2.x</td> </tr> <tr> <td>• Watchdog</td> <td>8.x</td> <td>4.11.x</td> </tr> <tr> <td>• Charge Pump</td> <td>9.x</td> <td>4.3.x</td> </tr> <tr> <td>• 5 V Regulator</td> <td>10.x</td> <td>4.4.x</td> </tr> <tr> <td>• General information</td> <td>10.x</td> <td>4.1.x</td> </tr> </tbody> </table> <p>Absolute Maximum Ratings: Digital I/Os (reference M6, M7, M8) changed to -0.5 to 7 V</p>		TLE 5200/01	TLE 6210/11	• Control input SIA	1.x	4.8.x	• Control input MRA	1.x	4.7.x	• Enable	2.x	4.5.x	• Reset outputs	3.x	4.10.x	• SILA/NSILA	4.x	4.8.x	• VR	5.x	4.6.x	• MR	5.x	4.7.x	• Voltage supervision	6.x	4.9.x	• Oscillator	7.x	4.2.x	• Watchdog	8.x	4.11.x	• Charge Pump	9.x	4.3.x	• 5 V Regulator	10.x	4.4.x	• General information	10.x	4.1.x
	TLE 5200/01	TLE 6210/11																																										
• Control input SIA	1.x	4.8.x																																										
• Control input MRA	1.x	4.7.x																																										
• Enable	2.x	4.5.x																																										
• Reset outputs	3.x	4.10.x																																										
• SILA/NSILA	4.x	4.8.x																																										
• VR	5.x	4.6.x																																										
• MR	5.x	4.7.x																																										
• Voltage supervision	6.x	4.9.x																																										
• Oscillator	7.x	4.2.x																																										
• Watchdog	8.x	4.11.x																																										
• Charge Pump	9.x	4.3.x																																										
• 5 V Regulator	10.x	4.4.x																																										
• General information	10.x	4.1.x																																										
V0.1	2001-11	Update truth table																																										
V0.2	2002-04	<p>increase error flag detection time <math>t_{FSP}</math> from 112 clock cycles to 120 clock cycles (parameter 4.11.8)</p> <p>Add of logic block diagram (figure 12) and watchdog timing diagrams (figure 5 to 10)</p>																																										

Revision History

Version	Date	Major Changes
V1.0	2002-07	Data sheet Remove pad / chip information from the datasheet ESD value SILA, MR, VR,UZP 4kV Update typ. value 4.3.3 Extend and correct block description at chapters 4.4; 4.6; 4.7; 4.8 Table 1: SILA function at overtemperature changed Table 2: timings as a function of $t_{CLK}$ Figure 11, t3: correct timing Chapter 4.11: Extend description; add figure 12: Detection of watchdog edges Appplciation diagram: replace free wheeling zener diodes at MR and VR relay by normal diodes.
V1.1	2002-07	change device suffixes: bare dice: TLE621x C packaged: TLE621x G
V1.2	2002-08	Table 1 and text chapter 4.8: correct NSILA at overvoltage Change long term drift 4.4.6 to 10000h Add a more detailed description to figure 12.

Integrated protection functions are designed to prevent IC destruction under fault conditions described in the data sheet. Fault conditions are considered as “outside” normal operating range. Protection functions are not designed for continuous repetitive operation.

Characteristics show the deviation of parameter at the given supply voltage and junction temperature. Typical values show the typical parameters expected from manufacturing.

**Edition 2002-08**

**Published by Infineon Technologies AG,  
St.-Martin-Strasse 53,  
D-81541 München, Germany**

**© Infineon Technologies AG 2002.  
All Rights Reserved.**

**Attention please!**

The information herein is given to describe certain components and shall not be considered as warranted characteristics.

Terms of delivery and rights to technical change reserved.

We hereby disclaim any and all warranties, including but not limited to warranties of non-infringement, regarding circuits, descriptions and charts stated herein.

Infineon Technologies is an approved CECC manufacturer.

**Information**

For further information on technology, delivery terms and conditions and prices please contact your nearest Infineon Technologies Office in Germany or our Infineon Technologies Representatives worldwide.

**Warnings**

Due to technical requirements components may contain dangerous substances. For information on the types in question please contact your nearest Infineon Technologies Office.

Infineon Technologies Components may only be used in life-support devices or systems with the express written approval of Infineon Technologies, if a failure of such components can reasonably be expected to cause the failure of that life-support device or system, or to affect the safety or effectiveness of that device or system. Life support devices or systems are intended to be implanted in the human body, or to support and/or maintain and sustain and/or protect human life. If they fail, it is reasonable to assume that the health of the user or other persons may be endangered.