



CAN-Transceiver

TLE 6250

TLE 6250 V33

Final Data Sheet

Features

- CAN data transmission rate up to 1 Mbaud
- Suitable for 12 V and 24 V applications
- Excellent EMC performance (very high immunity and very low emission)
- Version for 5 V and 3.3 V micro controllers
- Bus pins are short circuit proof to ground and battery voltage
- Over-temperature protection
- Very wide temperature range (- 40°C up to 150°C)



Type	Ordering Code	Package
TLE 6250 G	Q67006-A9427	P-DSO-8-3
TLE 6250 C	Q67000-A9594	(chip)
TLE 6250 G V33	Q67006-A9523	P-DSO-8-3
TLE 6250 C V33	Q67000-A9538	(chip)

Description

The CAN-transceiver TLE 6250 is a monolithic integrated circuit that is available as bare die as well as in a P-DSO-8-3 package. The IC is optimized for high speed differential mode data transmission in automotive and industrial applications and is compatible to ISO/DIS 11898 (see page 12 and 20). It works as an interface between the CAN protocol controller and the physical differential bus in both, 12 V and 24 V systems.

Note:

There are two versions available: one for 5 V logic and the other one for 3.3 V logic requiring additional supply via the V_{33V} pin. The IC can be set to stand-by mode via an control input. In addition the 5 V-version offers a receive only mode feature to support diagnostic functions.

The IC is based on the **Smart Power Technology SPT®** which allows bipolar and CMOS control circuitry in accordance with DMOS power devices existing on the same monolithic circuit. The TLE 6250 is designed to withstand the severe conditions of automotive applications and provides excellent EMC performance.



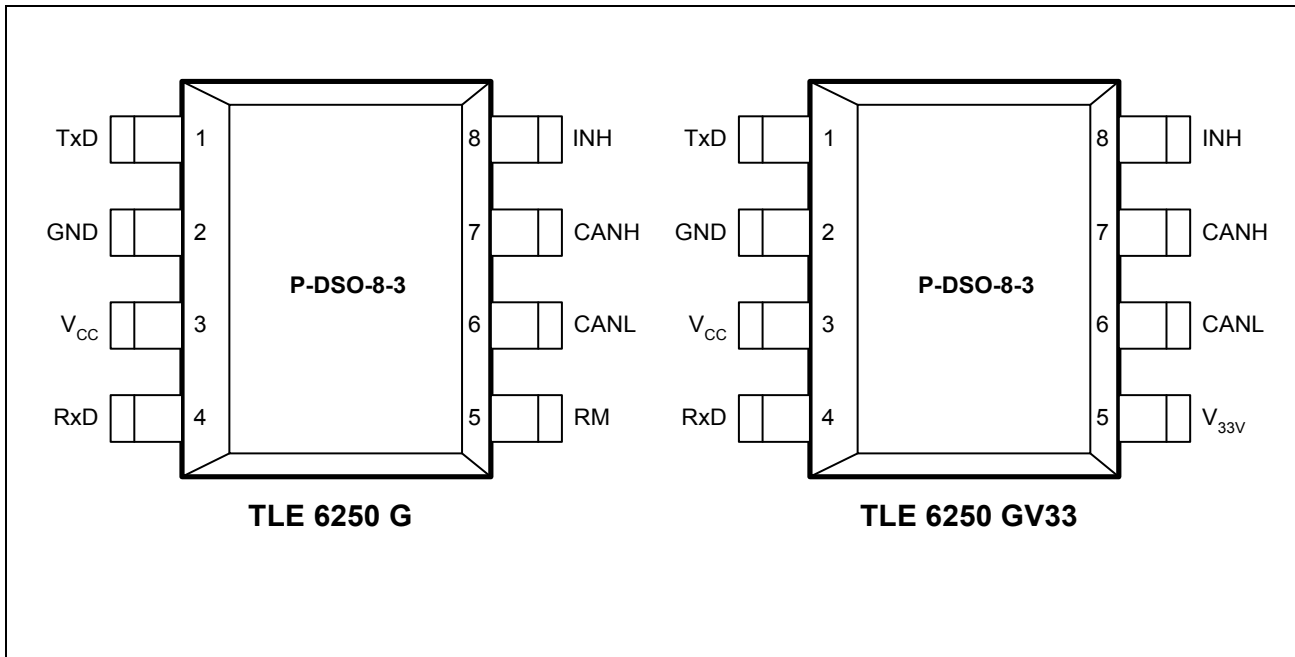

Figure 1 Pin Configuration (top view)

Pin Definitions and Functions

Pin No.	Symbol	Function
1	TxD	CAN transmit data input; 20 kΩ pull up, LOW in dominant state
2	GND	Ground;
3	V _{CC}	5 V Supply;
4	RxD	CAN receive data output; LOW in dominant state, integrated pull up
5	RM	Receive-only input; (5 V-version), 20 kΩ pull up, set low to activate RxD-only mode
	V _{33V}	Logic supply; (3.3 V-version) <u>3.3 V OR 5V</u> microcontroller logic supply can be connected here! The digital I/Os of the TLE6250V33 adopt to the connected microcontroller logic supply at V _{33V}
6	CANL	Low line input; LOW in dominant state
7	CANH	High line output; HIGH in dominant state
8	INH	Control input; 20 kΩ pull, set LOW for normal mode

Functional Block Diagram

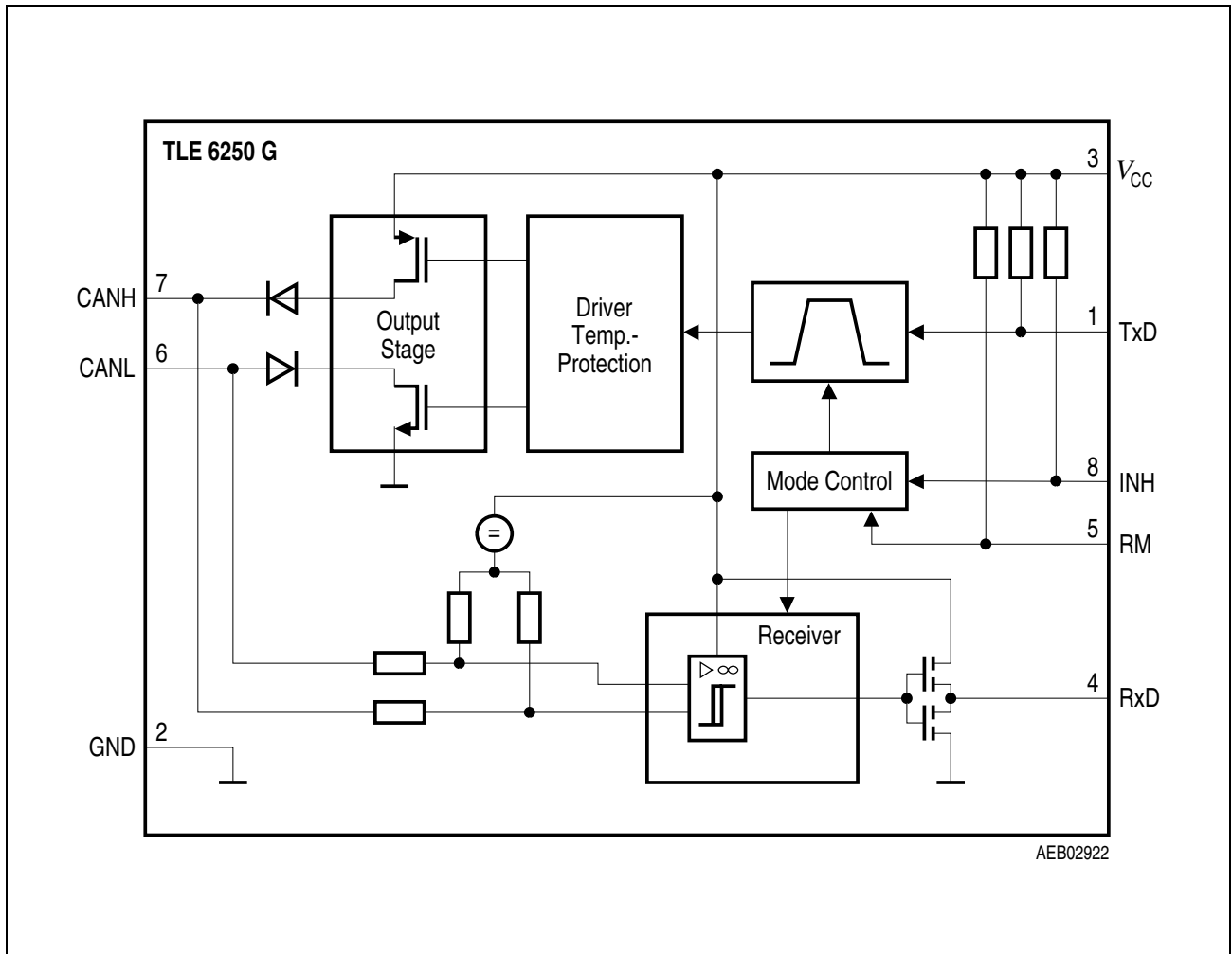

Figure 2 Block Diagram TLE 6250 G

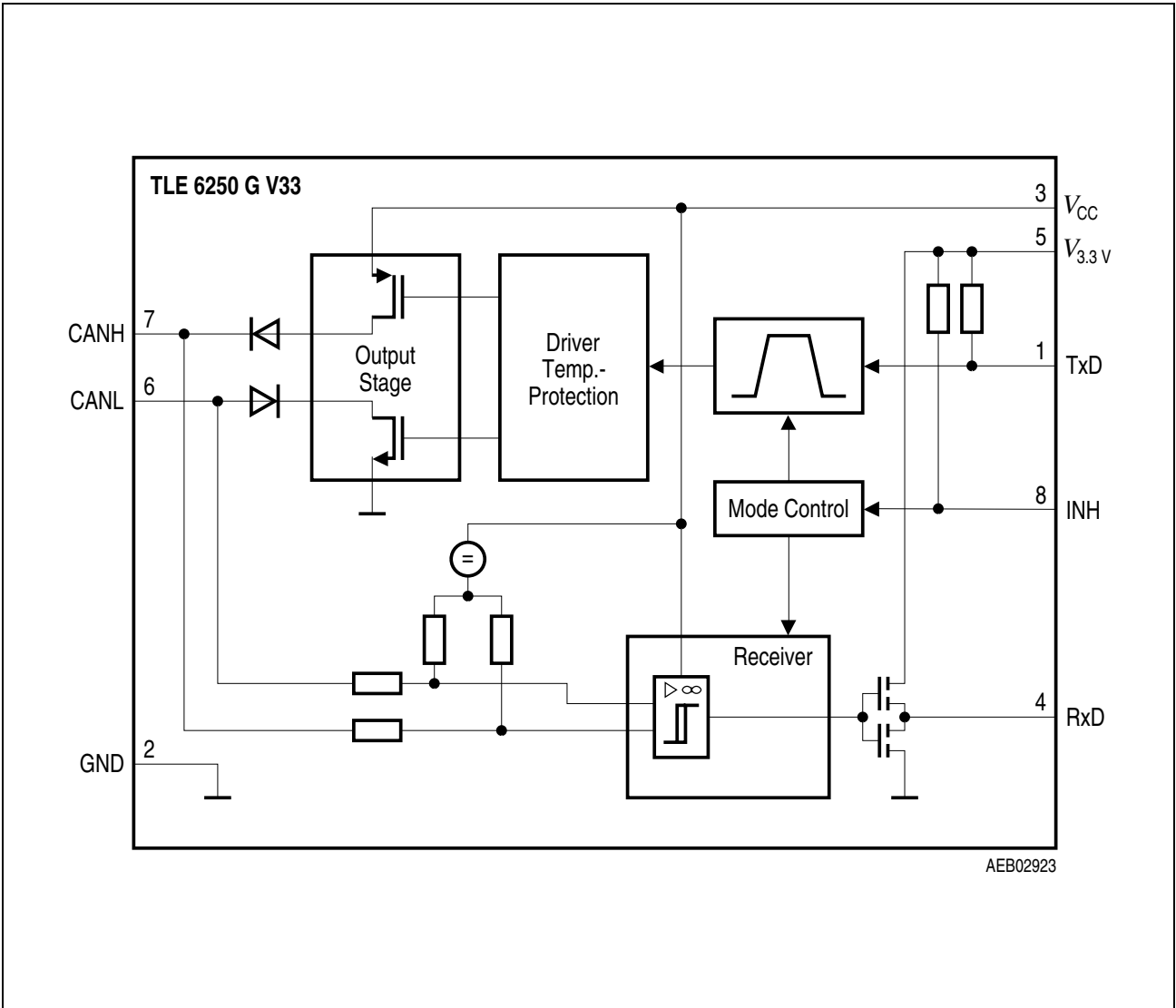

Figure 3 **Block Diagram TLE 6250 G V33**

Application Information

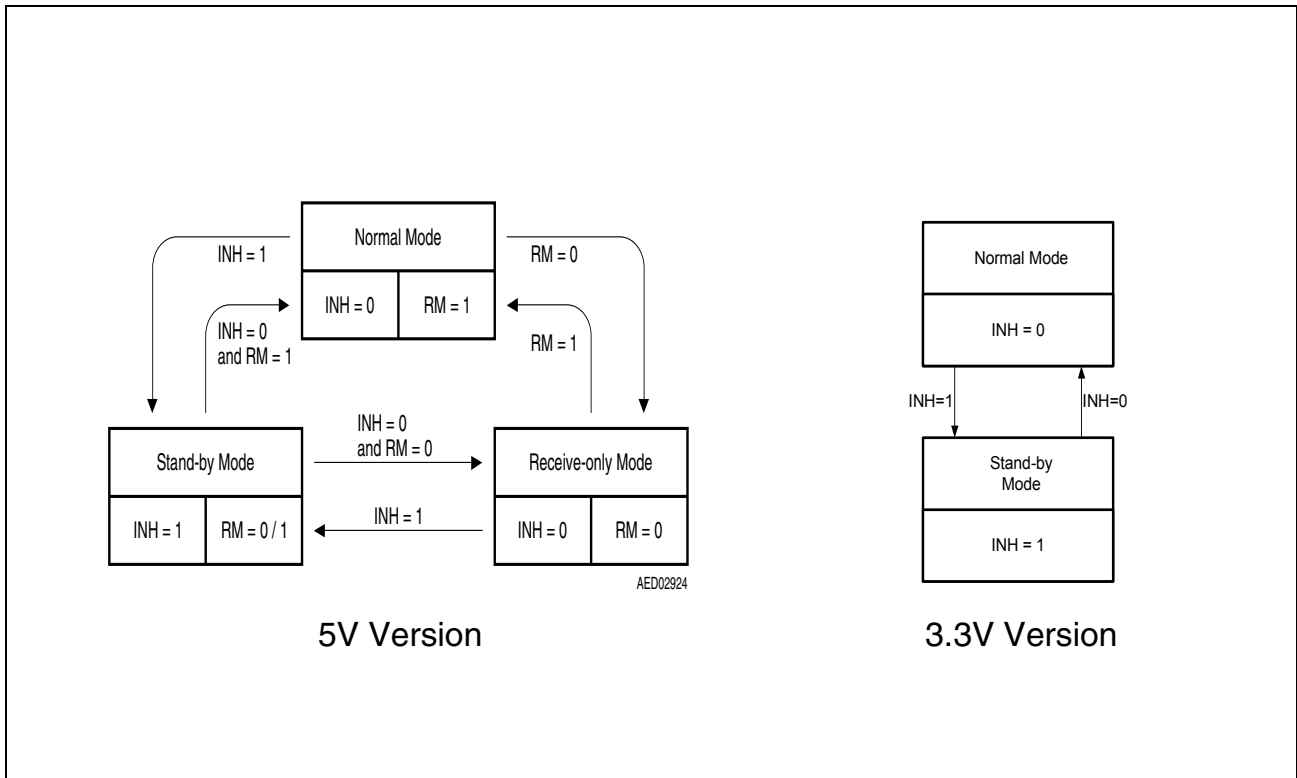

Figure 4 Mode State Diagram

Both, the TLE 6250 G as well as the TLE 6250 C offer three different operation modes (see **Figure 4**), controlled by the INH and RM pin for the TLE6250 and only by the INH pin for the 6250 V33. In the normal mode the device is able to receive and to transmit messages whereas in the receive-only mode signals at the TxD input are not transmitted to the CAN bus. The receive-only mode can be used for diagnostic purposes as well as to prevent the bus being blocked by a faulty permanent dominant TxD input signal. The stand-by mode is a low power mode that disables both, the receiver as well as the transmitter. For the TLE 6250 G V33 and TLE 6250 C V33 the receive only mode feature is not available. The inhibit feature for this versions works in the same way as for the 5V versions.

In case the receive-only feature is not used the RM pin has to be left open. When the stand-by mode is not used the INH pin has to be connected to ground level in order to switch the TLE 6250 in normal mode.

Application Information for the 3.3V Version

The TLE 6250V33 can be used for both; 3.3V and 5V microcontroller logic supply as shown below. Don't apply external resistors between the power supply and this pin. This may cause a voltage drop and so reduce the available voltage at this pin.

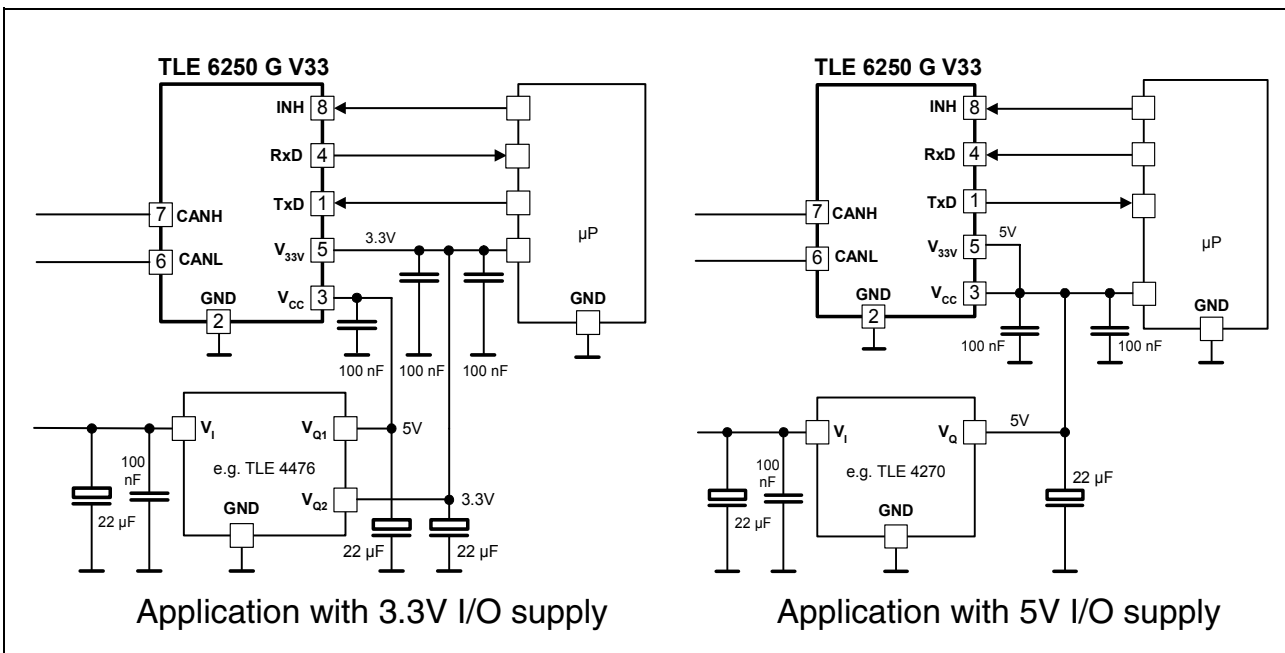

Electrical Characteristics TLE6250 G (5V Version)

Electrical Characteristics
Absolute Maximum Ratings

Parameter	Symbol	Limit Values		Unit	Remarks
		min.	max.		

Voltages

Supply voltage	V_{CC}	- 0.3	6.5	V	-
CAN input voltage (CANH, CANL)	$V_{CANH/L}$	- 40	40	V	-
Logic voltages at INH, RM, TxD, RxD	V_I	- 0.3	V_{CC}	V	$0\text{ V} < V_{CC} < 5.5\text{ V}$
Electrostatic discharge voltage at CANH, CANL	V_{ESD}	- 6	6	kV	human body model (100 pF via 1.5 k Ω)
Electrostatic discharge voltage	V_{ESD}	- 2	2	kV	human body model (100 pF via 1.5 k Ω)

Temperatures

Junction temperature	T_j	- 40	160	$^{\circ}\text{C}$	-
----------------------	-------	------	-----	--------------------	---

Note: Maximum ratings are absolute ratings; exceeding any one of these values may cause irreversible damage to the integrated circuit.

Operating Range

Parameter	Symbol	Limit Values		Unit	Remarks
		min.	max.		
Supply voltage	V_{CC}	4.5	5.5	V	–
Junction temperature	T_j	– 40	150	°C	–

Thermal Resistances

Junction ambient	R_{thj-a}	–	185	K/W	–
------------------	-------------	---	-----	-----	---

Thermal Shutdown (junction temperature)

Thermal shutdown temperature	T_{jSD}	160	200	°C	10 °C hysteresis
------------------------------	-----------	-----	-----	----	------------------

Electrical Characteristics

4.5 V < V_{CC} < 5.5 V; $R_L = 60 \Omega$; $V_{INH} < V_{INH,ON}$; $-40 \text{ }^\circ\text{C} < T_j < 150 \text{ }^\circ\text{C}$; all voltages with respect to ground; positive current flowing into pin; unless otherwise specified.

Parameter	Symbol	Limit Values			Unit	Remarks
		min.	typ.	max.		

Current Consumption

Current consumption	I_{CC}	–	6	10	mA	recessive state; $V_{TxD} = V_{CC}$
Current consumption	I_{CC}	–	45	70	mA	dominant state; $V_{TxD} = 0 \text{ V}$
Current consumption	I_{CC}	–	6	10	mA	receive-only mode; RM = low
Current consumption	$I_{CC,stab}$	–	1	10	μA	stand-by mode; TxD = RM = high

Receiver Output RxD

HIGH level output current	$I_{RD,H}$	–	-4	-2	mA	$V_{RD} = 0.8 \times V_{CC}$, $V_{diff} < 0.4 \text{ V}^{(note 1)}$
LOW level output current	$I_{RD,L}$	2	4	–	mA	$V_{RD} = 0.2 \times V_{CC}$, $V_{diff} > 1 \text{ V}^{(note 1)}$

Transmission Input TxD

HIGH level input voltage threshold	$V_{TD,H}$	–	$0.5 \times V_{CC}$	$0.7 \times V_{CC}$	V	recessive state;
LOW level input voltage threshold	$V_{TD,L}$	$0.3 \times V_{CC}$	$0.4 \times V_{CC}$	–	V	dominant state
TxD pull up resistance	R_{TD}	10	25	50	k Ω	–

note1) $V_{diff} = V_{CANH} - V_{CANL}$

Electrical Characteristics (cont'd)

4.5 V < V_{CC} < 5.5 V; R_L = 60 Ω; V_{INH} < V_{INH,ON}; - 40 °C < T_j < 150 °C; all voltages with respect to ground; positive current flowing into pin; unless otherwise specified.

Parameter	Symbol	Limit Values			Unit	Remarks
		min.	typ.	max.		

Inhibit Input (pin INH)

HIGH level input voltage threshold	V _{INH,H}	–	0.5× V _{CC}	0.7× V _{CC}	V	stand-by mode;
LOW level input voltage threshold	V _{INH,L}	0.3× V _{CC}	0.4× V _{CC}	–	V	normal mode
INH pull up resistance	R _{INH}	10	25	50	kΩ	–

Receive only Input (RM) (5V version only)

HIGH level input voltage threshold	V _{RM,H}	–	0.5× V _{CC}	0.7× V _{CC}	V	normal mode;
LOW level input voltage threshold	V _{RM,L}	0.3× V _{CC}	0.4× V _{CC}	–	V	receive-only mode
RM pull up resistance	R _{RM}	10	25	50	kΩ	–

Electrical Characteristics (cont'd)

4.5 V < V_{CC} < 5.5 V; R_L = 60 Ω; V_{INH} < V_{INH,ON}; -40 °C < T_j < 150 °C; all voltages with respect to ground; positive current flowing into pin; unless otherwise specified.

Parameter	Symbol	Limit Values			Unit	Remarks
		min.	typ.	max.		

Bus Receiver

Differential receiver threshold voltage, recessive to dominant edge	V _{diff,d}	–	0.75	0.90	V	-20 V < (V _{CANH} , V _{CANL}) < 25 V V _{diff} = V _{CANH} - V _{CANL}
Differential receiver threshold voltage dominant to recessive edge	V _{diff,r}	0.50	0.60	–	V	-20 V < (V _{CANH} , V _{CANL}) < 25 V V _{diff} = V _{CANH} - V _{CANL}
Common Mode Range	CMR	-20	–	25	V	V _{CC} = 5V
Differential receiver hysteresis	V _{diff,hys}	–	150	–	mV	–
CANH, CANL input resistance	R _i	10	20	30	kΩ	recessive state
Differential input resistance	R _{diff}	20	40	60	kΩ	recessive state

Electrical Characteristics (cont'd)

4.5 V < V_{CC} < 5.5 V; R_L = 60 Ω; V_{INH} < V_{INH,ON}; -40 °C < T_j < 150 °C; all voltages with respect to ground; positive current flowing into pin; unless otherwise specified.

Parameter	Symbol	Limit Values			Unit	Remarks
		min.	typ.	max.		

Bus Transmitter

CANL/CANH recessive output voltage	V _{CANL/H}	0.4 × V _{CC}	–	0.6 × V _{CC}	V	V _{TxD} = V _{CC}
CANH, CANL recessive output voltage difference V _{diff} = V _{CANH} – V _{CANL} no load; (see note 2)	V _{diff}	- 1	–	0.05	V	V _{TxD} = V _{CC}
CANL dominant output voltage	V _{CANL}	–	–	2.0	V	V _{TxD} = 0 V; V _{CC} = 5 V
CANH dominant output voltage	V _{CANH}	2.8	–	–	V	V _{TxD} = 0 V; V _{CC} = 5 V
CANH, CANL dominant output voltage difference V _{diff} = V _{CANH} – V _{CANL}	V _{diff}	1.5	–	3.0	V	V _{TxD} = 0 V; V _{CC} = 5 V
CANL short circuit current	I _{CANLsc}	50	120	200	mA	V _{CANLshort} = 18 V
		–	150	–	mA	V _{CANLshort} = 36 V
CANH short circuit current	I _{CANHsc}	-200	-120	-50	mA	V _{CANHshort} = 0 V
CANH short circuit current	I _{CANHsc}	–	-120	–	mA	V _{CANHshort} = -5 V
Output current	I _{CANH,Ik}	-50	-300	-400	μA	V _{CC} = 0 V, V _{CANH} = V _{CANL} = -7 V
		-50	-100	-150	μA	V _{CC} = 0 V, V _{CANH} = V _{CANL} = -2 V
Output current	I _{CANH,Ik}	50	280	400	μA	V _{CC} = 0 V, V _{CANH} = V _{CANL} = 7 V
		50	100	150	μA	V _{CC} = 0 V, V _{CANH} = V _{CANL} = 2 V

note 2) deviation from ISO/DIS 11898

Electrical Characteristics (cont'd)

4.5 V < V_{CC} < 5.5 V; R_L = 60 Ω; V_{INH} < V_{INH,ON}; - 40 °C < T_j < 150 °C; all voltages with respect to ground; positive current flowing into pin; unless otherwise specified.

Parameter	Symbol	Limit Values			Unit	Remarks
		min.	typ.	max.		

Dynamic CAN-Transceiver Characteristics

Propagation delay TxD-to-RxD LOW (recessive to dominant)	$t_{d(L),TR}$	–	150	280	ns	C _L = 47 pF; R _L = 60 Ω; V _{CC} = 5 V; C _{RxD} = 20 pF
Propagation delay TxD-to-RxD HIGH (dominant to recessive)	$t_{d(H),TR}$	–	150	280	ns	C _L = 47 pF; R _L = 60 Ω; V _{CC} = 5 V; C _{RxD} = 20 pF
Propagation delay TxD LOW to bus dominant	$t_{d(L),T}$	–	100	140	ns	C _L = 47 pF; R _L = 60 Ω; V _{CC} = 5 V
Propagation delay TxD HIGH to bus recessive	$t_{d(H),T}$	–	100	140	ns	C _L = 47 pF; R _L = 60 Ω; V _{CC} = 5 V
Propagation delay bus dominant to RxD LOW	$t_{d(L),R}$	–	50	140	ns	C _L = 47 pF; R _L = 60 Ω; V _{CC} = 5 V; C _{RxD} = 20 pF
Propagation delay bus recessive to RxD HIGH	$t_{d(H),R}$	–	50	140	ns	C _L = 47 pF; R _L = 60 Ω; V _{CC} = 5 V; C _{RxD} = 20 pF

1)

Electrical Characteristics TLE6250 GV33 (3.3V Version)

Electrical Characteristics
Absolute Maximum Ratings

Parameter	Symbol	Limit Values		Unit	Remarks
		min.	max.		

Voltages

Supply voltage	V_{CC}	- 0.3	6.5	V	-
3.3 V supply	V_{33V}	- 0.3	5.5	V	-
CAN input voltage (CANH, CANL)	$V_{CANH/L}$	- 40	40	V	-
Logic voltages at INH, RM, TxD, RxD	V_I	- 0.3	V_{CC}	V	$0\text{ V} < V_{CC} < 5.5\text{ V}$
Electrostatic discharge voltage at CANH,CANL	V_{ESD}	- 6	6	kV	human body model (100 pF via 1.5 k Ω)
Electrostatic discharge voltage	V_{ESD}	- 2	2	kV	human body model (100 pF via 1.5 k Ω)

Temperatures

Junction temperature	T_j	- 40	160	$^{\circ}\text{C}$	-
----------------------	-------	------	-----	--------------------	---

Note: Maximum ratings are absolute ratings; exceeding any one of these values may cause irreversible damage to the integrated circuit.

Operating Range

Parameter	Symbol	Limit Values		Unit	Remarks
		min.	max.		
Supply voltage	V_{CC}	4.5	5.5	V	–
3.3 V supply voltage	V_{33V}	3.0	5.5	V	–
Junction temperature	T_j	– 40	150	°C	–

Thermal Resistances

Junction ambient	R_{thj-a}	–	185	K/W	–
------------------	-------------	---	-----	-----	---

Thermal Shutdown (junction temperature)

Thermal shutdown temperature	T_{jsD}	160	200	°C	10 °C hysteresis
------------------------------	-----------	-----	-----	----	------------------

Electrical Characteristics

4.5 V < V_{CC} < 5.5 V; (3.0 V < V_{33V} < 3.6 V for 3.3 V version); $R_L = 60 \Omega$; $V_{INH} < V_{INH,ON}$; $-40 \text{ }^\circ\text{C} < T_j < 150 \text{ }^\circ\text{C}$; all voltages with respect to ground; positive current flowing into pin; unless otherwise specified.

Parameter	Symbol	Limit Values			Unit	Remarks
		min.	typ.	max.		

Current Consumption (3.3V version)

Current consumption	I_{CC+33V}	–	6	10	mA	recessive state; $V_{TxD} = V_{33V}$
Current consumption	I_{CC+33V}	–	45	70	mA	dominant state; $V_{TxD} = 0 \text{ V}$
Current consumption	I_{33V}	–	–	2	mA	
Current consumption	$I_{CC+33V, stb}$	–	1	10	μA	stand-by mode TxD = high

Receiver Output RxD

HIGH level output current	$I_{RD,H}$	–	-2	-1	mA	$V_{RD} = 0.8 \times V_{33V}$, $V_{diff} < 0.4 \text{ V}^{(\text{note } 1)}$
LOW level output current	$I_{RD,L}$	1	2	–	mA	$V_{RD} = 0.2 \times V_{33V}$, $V_{diff} > 1 \text{ V}^{(\text{note } 1)}$

Transmission Input TxD

HIGH level input voltage threshold	$V_{TD,H}$	–	$0.55 \times V_{33V}$	$0.7 \times V_{33V}$	V	recessive state;
LOW level input voltage threshold	$V_{TD,L}$	$0.3 \times V_{33V}$	$0.45 \times V_{33V}$	–	V	dominant state;
TxD pull up resistance	R_{TD}	10	25	50	k Ω	–

note1) $V_{diff} = V_{CANH} - V_{CANL}$

Electrical Characteristics (cont'd)

4.5 V < V_{CC} < 5.5 V; (3.0 V < V_{33V} < 3.6 V for 3.3 V version); $R_L = 60 \Omega$; $V_{INH} < V_{INH,ON}$; $-40 \text{ }^\circ\text{C} < T_j < 150 \text{ }^\circ\text{C}$; all voltages with respect to ground; positive current flowing into pin; unless otherwise specified.

Parameter	Symbol	Limit Values			Unit	Remarks
		min.	typ.	max.		

Inhibit Input (pin INH)

HIGH level input voltage threshold	$V_{INH,H}$	–	$0.55 \times V_{33V}$	$0.7 \times V_{33V}$	V	stand-by mode;
LOW level input voltage threshold	$V_{INH,L}$	$0.3 \times V_{33V}$	$0.45 \times V_{33V}$	–	V	normal mode;
INH pull up resistance	R_{INH}	10	25	50	k Ω	–

Electrical Characteristics (cont'd)

4.5 V < V_{CC} < 5.5 V; (3.0 V < V_{33V} < 3.6 V for 3.3 V version); $R_L = 60 \Omega$; $V_{INH} < V_{INH,ON}$; $-40 \text{ }^\circ\text{C} < T_j < 150 \text{ }^\circ\text{C}$; all voltages with respect to ground; positive current flowing into pin; unless otherwise specified.

Parameter	Symbol	Limit Values			Unit	Remarks
		min.	typ.	max.		

Bus Receiver

Differential receiver threshold voltage, recessive to dominant edge	$V_{diff,d}$	–	0.75	0.90	V	$-20 \text{ V} < (V_{CANH}, V_{CANL}) < 25 \text{ V}$ $V_{diff} = V_{CANH} - V_{CANL}$
Differential receiver threshold voltage dominant to recessive edge	$V_{diff,r}$	0.50	0.60	–	V	$-20 \text{ V} < (V_{CANH}, V_{CANL}) < 25 \text{ V}$ $V_{diff} = V_{CANH} - V_{CANL}$
Common Mode Range	CMR	-20	–	25	V	$V_{CC} = 5\text{V}$
Differential receiver hysteresis	$V_{diff,hys}$	–	150	–	mV	–
CANH, CANL input resistance	R_i	10	20	30	k Ω	recessive state
Differential input resistance	R_{diff}	20	40	60	k Ω	recessive state

Electrical Characteristics (cont'd)

4.5 V < V_{CC} < 5.5 V; (3.0 V < V_{33V} < 3.6 V for 3.3 V version); $R_L = 60 \Omega$; $V_{INH} < V_{INH,ON}$; $-40 \text{ }^\circ\text{C} < T_j < 150 \text{ }^\circ\text{C}$; all voltages with respect to ground; positive current flowing into pin; unless otherwise specified.

Parameter	Symbol	Limit Values			Unit	Remarks
		min.	typ.	max.		

Bus Transmitter

CANL/CANH recessive output voltage	$V_{CANL/H}$	$0.4 \times V_{CC}$	–	$0.6 \times V_{CC}$	V	$V_{TxD} = V_{33V}$
CANH, CANL recessive output voltage difference $V_{diff} = V_{CANH} - V_{CANL}$ no load; (see note 2)	V_{diff}	- 1	–	0.05	V	$V_{TxD} = V_{33V}$
CANL dominant output voltage	V_{CANL}	–	–	2.0	V	$V_{TxD} = 0 \text{ V}$; $V_{CC} = 5 \text{ V}$
CANH dominant output voltage	V_{CANH}	2.8	–	–	V	$V_{TxD} = 0 \text{ V}$; $V_{CC} = 5 \text{ V}$
CANH, CANL dominant output voltage difference $V_{diff} = V_{CANH} - V_{CANL}$	V_{diff}	1.5	–	3.0	V	$V_{TxD} = 0 \text{ V}$; $V_{CC} = 5 \text{ V}$
CANL short circuit current	I_{CANLsc}	50	120	200	mA	$V_{CANLshort} = 18 \text{ V}$
		–	150	–	mA	$V_{CANLshort} = 36 \text{ V}$
CANH short circuit current	I_{CANHsc}	-200	-120	-50	mA	$V_{CANHshort} = 0 \text{ V}$
CANH short circuit current	I_{CANHsc}	–	-120	–	mA	$V_{CANHshort} = -5 \text{ V}$
Output current	$I_{CANH,ik}$	-50	-300	-400	μA	$V_{CC} = 0 \text{ V}$, $V_{CANH} = V_{CANL} = -7 \text{ V}$
		-50	-100	-150	μA	$V_{CC} = 0 \text{ V}$, $V_{CANH} = V_{CANL} = -2 \text{ V}$
Output current	$I_{CANH,ik}$	50	280	300	μA	$V_{CC} = 0 \text{ V}$, $V_{CANH} = V_{CANL} = 7 \text{ V}$
		50	100	150	μA	$V_{CC} = 0 \text{ V}$, $V_{CANH} = V_{CANL} = 2 \text{ V}$

note 2) deviation from ISO/DIS 11898

Electrical Characteristics (cont'd)

4.5 V < V_{CC} < 5.5 V; (3.0 V < V_{33V} < 3.6 V for 3.3 V version); $R_L = 60 \Omega$; $V_{INH} < V_{INH,ON}$; $-40 \text{ }^\circ\text{C} < T_j < 150 \text{ }^\circ\text{C}$; all voltages with respect to ground; positive current flowing into pin; unless otherwise specified.

Parameter	Symbol	Limit Values			Unit	Remarks
		min.	typ.	max.		

Dynamic CAN-Transceiver Characteristics

Propagation delay TxD-to-RxD LOW (recessive to dominant)	$t_{d(L),TR}$	–	150	280	ns	$C_L = 47 \text{ pF}$; $R_L = 60 \Omega$; $V_{CC} = 5 \text{ V}$; $C_{RxD} = 20 \text{ pF}$
Propagation delay TxD-to-RxD HIGH (dominant to recessive)	$t_{d(H),TR}$	–	150	280	ns	$C_L = 47 \text{ pF}$; $R_L = 60 \Omega$; $V_{CC} = 5 \text{ V}$; $C_{RxD} = 20 \text{ pF}$
Propagation delay TxD LOW to bus dominant	$t_{d(L),T}$	–	100	140	ns	$C_L = 47 \text{ pF}$; $R_L = 60 \Omega$; $V_{CC} = 5 \text{ V}$
Propagation delay TxD HIGH to bus recessive	$t_{d(H),T}$	–	100	140	ns	$C_L = 47 \text{ pF}$; $R_L = 60 \Omega$; $V_{CC} = 5 \text{ V}$
Propagation delay bus dominant to RxD LOW	$t_{d(L),R}$	–	50	140	ns	$C_L = 47 \text{ pF}$; $R_L = 60 \Omega$; $V_{CC} = 5 \text{ V}$; $C_{RxD} = 20 \text{ pF}$
Propagation delay bus recessive to RxD HIGH	$t_{d(H),R}$	–	50	140	ns	$C_L = 47 \text{ pF}$; $R_L = 60 \Omega$; $V_{CC} = 5 \text{ V}$; $C_{RxD} = 20 \text{ pF}$

Diagrams

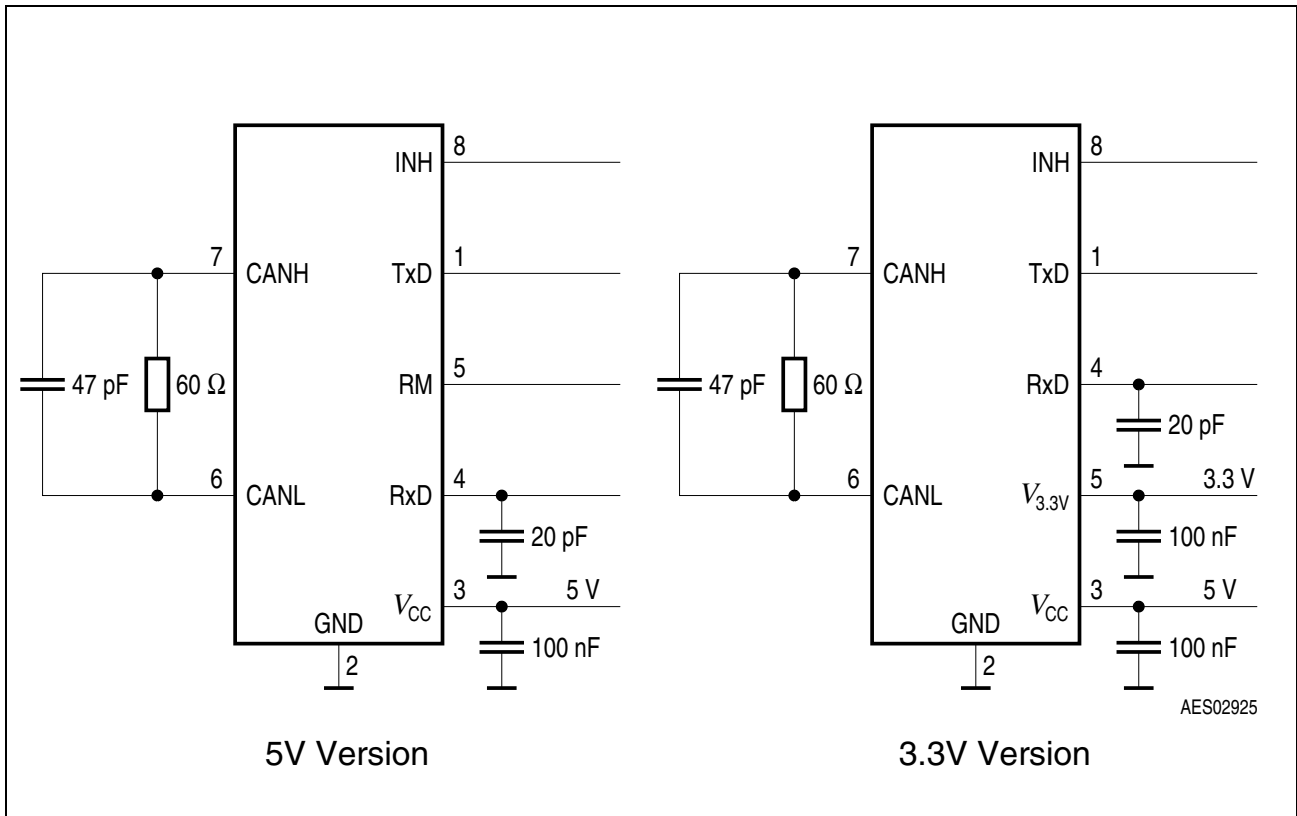

Figure 5 Test Circuits for Dynamic Characteristics

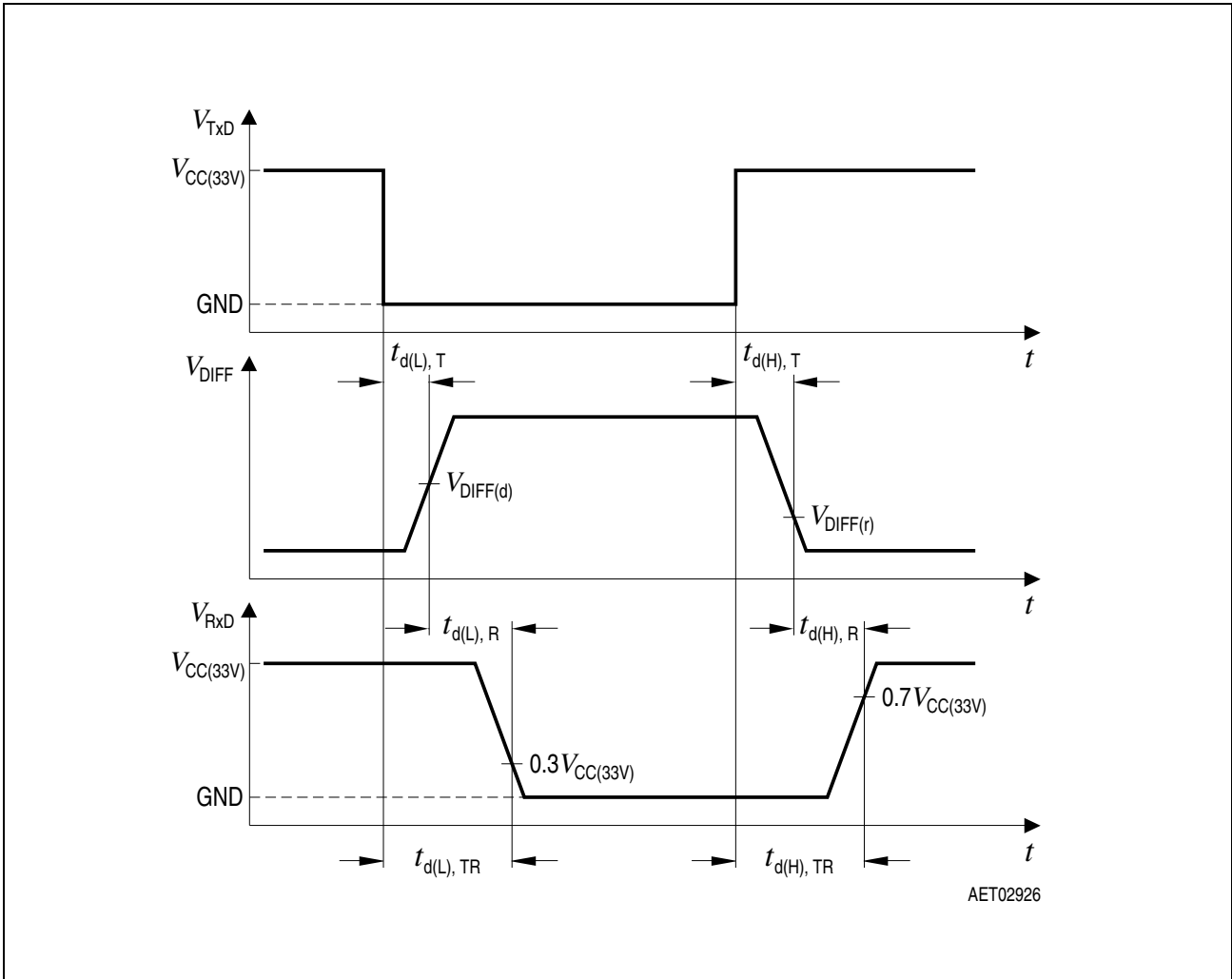

Figure 6 Timing Diagrams for Dynamic Characteristics

Application

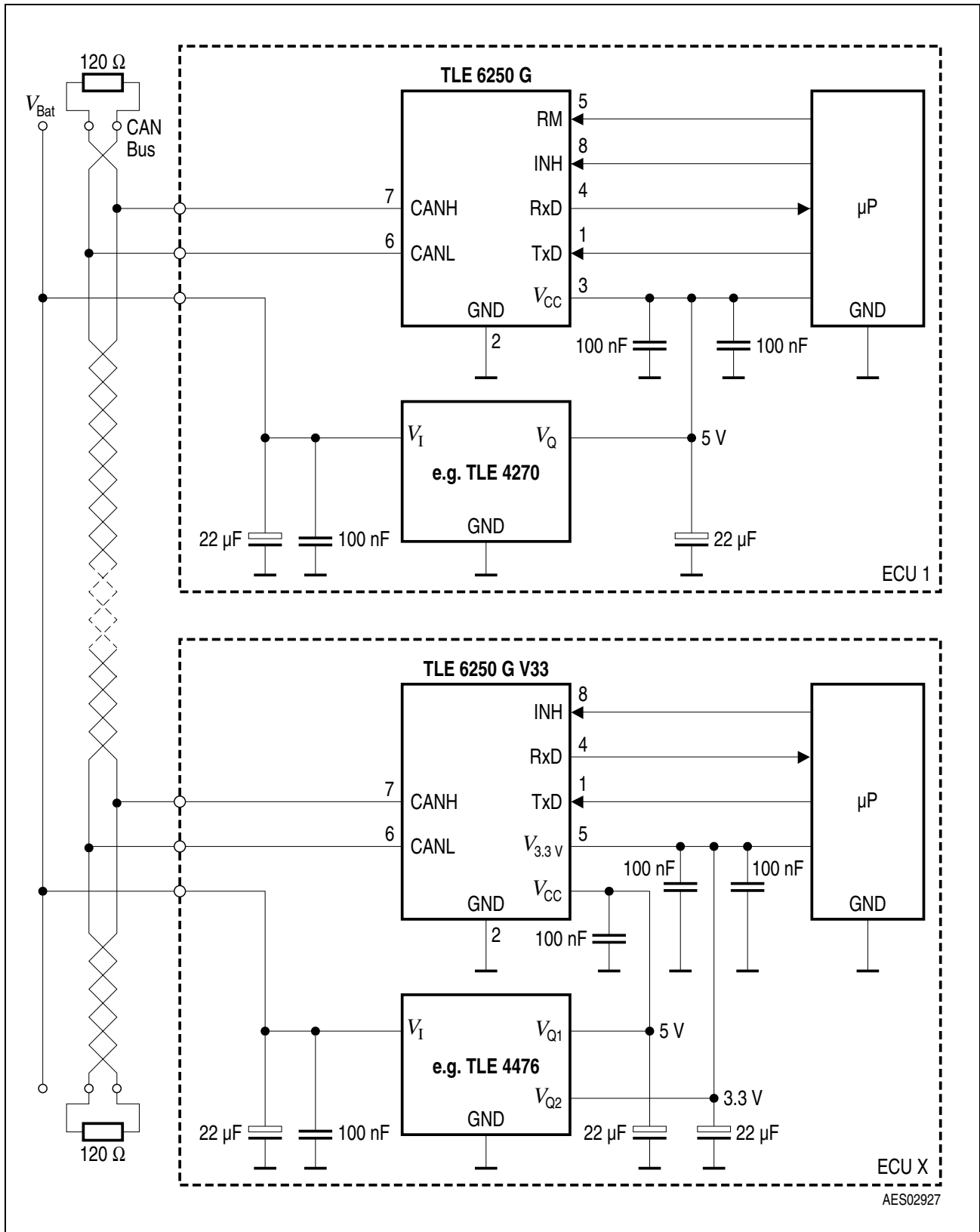
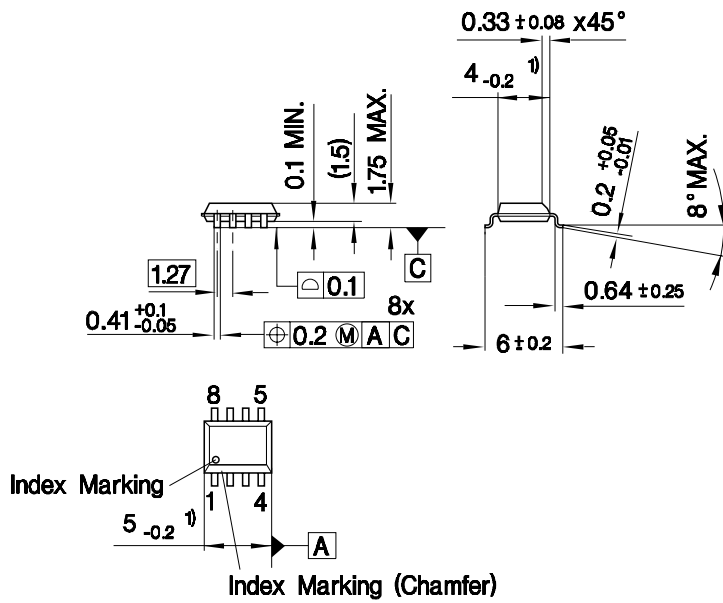

Figure 7 Application Circuit

Package Outlines

P-DSO-8-3 (Plastic Dual Small Outline Package)



1) Does not include plastic or metal protrusion of 0.15 max. per side

GPS09032

Sorts of Packing

Package outlines for tubes, trays etc. are contained in our Data Book "Package Information"

SMD = Surface Mounted Device

Dimensions in mm

Edition 2002-10-08

**Published by Infineon Technologies AG,
St.-Martin-Strasse 53,
D-81541 München, Germany**

**© Infineon Technologies AG 2002.
All Rights Reserved.**

Attention please!

The information herein is given to describe certain components and shall not be considered as warranted characteristics.

Terms of delivery and rights to technical change reserved.

We hereby disclaim any and all warranties, including but not limited to warranties of non-infringement, regarding circuits, descriptions and charts stated herein.

Infineon Technologies is an approved CECC manufacturer.

Information

For further information on technology, delivery terms and conditions and prices please contact your nearest Infineon Technologies Office in Germany or our Infineon Technologies Representatives worldwide (see address list).

Warnings

Due to technical requirements components may contain dangerous substances. For information on the types in question please contact your nearest Infineon Technologies Office.

Infineon Technologies Components may only be used in life-support devices or systems with the express written approval of Infineon Technologies, if a failure of such components can reasonably be expected to cause the failure of that life-support device or system, or to affect the safety or effectiveness of that device or system. Life support devices or systems are intended to be implanted in the human body, or to support and/or maintain and sustain and/or protect human life. If they fail, it is reasonable to assume that the health of the user or other persons may be endangered.