



ADJUSTABLE LED DRIVER

FEATURES

- Adjustable Constant Current up to 500 mA ($\pm 5\%$)
- Wide Input Voltage Range up to 42 V
- Low Drop Voltage
- Open-Load Detection
- Overtemperature Protection
- Short-Circuit Proof
- Reverse-Polarity Proof
- Wide Temperature Range: -40°C to 150°C

DRJ (QFN) PACKAGE
(TOP VIEW)

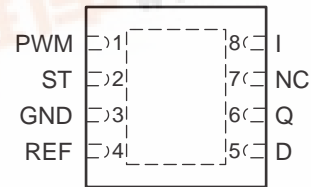

NC – No internal connection

DESCRIPTION/ORDERING INFORMATION

The TL4242 is an integrated adjustable constant-current source, driving loads up to 500 mA. The output current level can be adjusted via an external resistor. The device is designed to supply high-power LEDs (for example, OSRAM Dragon LA W57B) under the severe conditions of automotive applications, resulting in constant brightness and extended LED lifetime. It is provided in the DRJ (QFN) package. Protection circuits prevent damage to the device in case of overload, short circuit, reverse polarity, and overheat. The connected LEDs are protected against reverse polarity as well as excess voltages up to 45 V.

The integrated PWM input of the TL4242 permits LED brightness regulation by pulse-width modulation (PWM). Due to the high input impedance of the PWM input, the LED driver can be operated as a protected high-side switch.

The TL4242 is characterized for operation from -40°C to 150°C .

An external shunt resistor in the ground path of the connected LEDs is used to sense the LED current. A regulation loop holds the voltage drop at the shunt resistor at a constant level of 177 mV (typ). The constant-current level can be adjusted by selecting the shunt resistance, R_{REF} . Calculate the typical output current using the equation:

$$I_{Q,typ} = V_{REF}/R_{REF}$$

where V_{REF} is the reference voltage (typically 177 mV) (see *Reference Electrical Characteristics*). The equation applies for $R_{REF} = 0.39 \Omega$ to 10Ω .

The output current is shown as a function of the reference resistance in [Figure 1](#). With the PWM input, the LED brightness can be regulated via duty cycle. Also, PWM = L sets the TL4242 in sleep mode, resulting in a very low current consumption of $<1 \mu\text{A}$ (typ). Due to the high impedance of the PWM input (see [Figure 4](#)), the PWM pin also can be used as an enable input.

ORDERING INFORMATION⁽¹⁾

T _J	PACKAGE ⁽²⁾		ORDERABLE PART NUMBER	TOP-SIDE MARKING
-40°C to 150°C	QFN – DRJ	Reel of 1000	TL4242DRJR	T4242

(1) For the most current package and ordering information, see the Package Option Addendum at the end of this document, or see the TI web site at www.ti.com.

(2) Package drawings, thermal data, and symbolization are available at www.ti.com/packaging.

TERMINAL FUNCTIONS

NO.	NAME	DESCRIPTION
1	PWM	Pulse-width modulation input. If not used, connect to I.
2	ST	Status output. Open-collector output. Connect to an external pullup resistor ($R_{PULLUP} \geq 4.7 \text{ k}\Omega$).
3	GND	Ground
4	REF	Reference input. Connect to a shunt resistor.
5	D	Status delay. To set status reaction delay, connect to GND with a capacitor. If no delay is needed, leave open.
6	Q	Output
7	NC	No internal connection
8	I	Input. Connect directly to GND as close as possible to the device with a 100-nF ceramic capacitor.

FUNCTIONAL BLOCK DIAGRAM

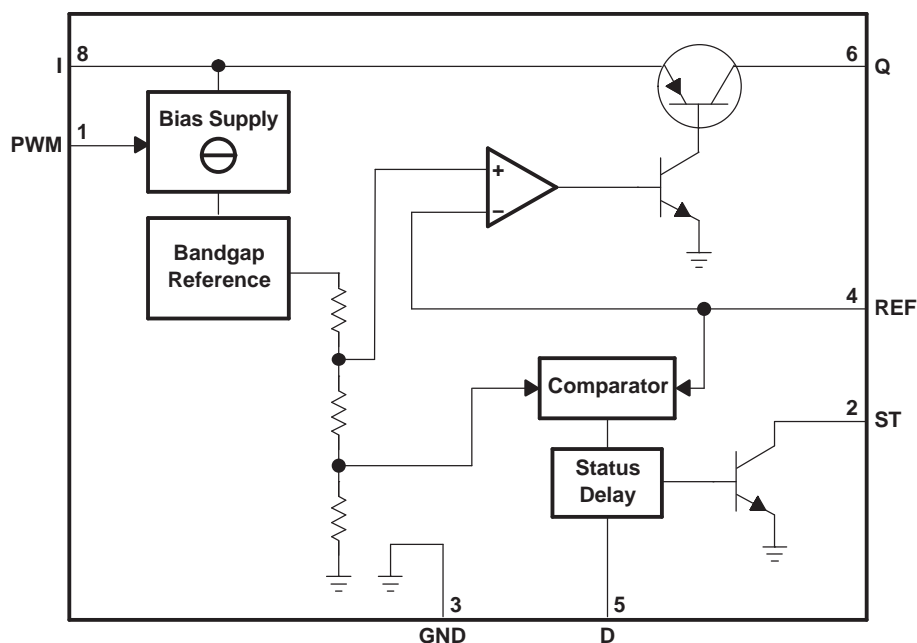

ABSOLUTE MAXIMUM RATINGS⁽¹⁾

over operating free-air temperature range (unless otherwise noted)

		MIN	MAX	UNIT	
V _{CC}	Supply voltage range ⁽²⁾	-42	45	V	
V _I	Input voltage range	D	-0.3	7	V
		PWM	-40	40	V
		REF	-1	16	V
V _O	Output voltage range	Q	-1	41	V
		ST	-0.3	40	V
I _O	Output current range	PWM		±1	mA
		REF		±2	mA
		ST		±5	mA
θ _{JA}	Thermal impedance, junction to ambient ⁽³⁾	JESD 51-5 ⁽⁴⁾		49.5	°C/W
		JESD 51-7 ⁽⁵⁾		114.4	
θ _{JP}	Thermal impedance, junction to pad ⁽³⁾		4.4	°C/W	
T _J	Virtual-junction temperature range	-40	150	°C	
T _{stg}	Storage temperature range	-50	150	°C	

- (1) Stresses beyond those listed under *Absolute Maximum Ratings* may cause permanent damage to the device. These are stress ratings only, and functional operation of the device at these or any other conditions beyond those indicated under *Recommended Operating Conditions* is not implied. Exposure to absolute-maximum-rated conditions for extended periods may affect device reliability.
- (2) All voltage values are with respect to the network ground terminal.
- (3) Maximum power dissipation is a function of T_{J(max)}, θ_{JA}, and T_A. The maximum allowable power dissipation at any allowable ambient temperature is P_D = (T_{J(max)} - T_A)/θ_{JA}. Operating at the absolute maximum T_J of 150°C can affect reliability.
- (4) The package thermal impedance is calculated in accordance with JESD 51-5.
- (5) The package thermal impedance is calculated in accordance with JESD 51-7.

RECOMMENDED OPERATING CONDITIONS

		MIN	MAX	UNIT
V _{CC}	Supply voltage	4.5	42	V
V _{ST}	Status (ST) output voltage		16	V
V _{PWM}	PWM voltage	0	40	V
C _D	Status delay (D) capacitance	0	2.2	μF
R _{REF}	Reference (REF) resistor	0	10	Ω
T _J	Virtual-junction temperature	-40	150	°C

OVERALL DEVICE ELECTRICAL CHARACTERISTICS

over recommended operating free-air temperature range, V_I = 13.5 V, R_{REF} = 0.47 Ω, V_{PWM,H}, T_J = -40°C to 150°C, all voltages with respect to ground (unless otherwise noted)

PARAMETER		TEST CONDITIONS		MIN	TYP	MAX	UNIT
I _{qL}	Supply current	V _Q = 6.6 V			12	22	mA
I _{qOFF}	Supply current, off mode	PWM = L, T _J < 85°C			0.1	2	μA

OUTPUT ELECTRICAL CHARACTERISTICS

over recommended operating free-air temperature range, $V_I = 13.5\text{ V}$, $R_{REF} = 0.47\ \Omega$, $V_{PWM,H}$, $T_J = -40^\circ\text{C}$ to 150°C , all voltages with respect to ground (unless otherwise noted)

PARAMETER		TEST CONDITIONS	MIN	TYP	MAX	UNIT
I_Q	Output current	$V_Q - V_{REF}^{(1)} = 6.6\text{ V}$	357	376	395	mA
		$V_Q - V_{REF} = 6.6\text{ V}$, $R_{REF} = 1\ \Omega$	168	177	185	
		$V_Q - V_{REF} = 6.6\text{ V}$, $R_{REF} = 0.39\ \Omega$	431	454	476	
		$V_Q - V_{REF} = 5.4\text{ V}$ to 7.8 V , $V_I = 9\text{ V}$ to 16 V	357	376	395	
I_{Qmax}	Output current limit	$R_{REF} = 0\ \Omega$		600		mA
V_{dr}	Drop voltage	$I_Q = 300\text{ mA}$		0.35	0.7	V

(1) $V_Q - V_{REF}$ equals the forward voltage sum of the connected LEDs (see Figure 3).

PWM INPUT ELECTRICAL CHARACTERISTICS

over recommended operating free-air temperature range, $V_I = 13.5\text{ V}$, $R_{REF} = 0.47\ \Omega$, $V_{PWM,H}$, $T_J = -40^\circ\text{C}$ to 150°C , all voltages with respect to ground (unless otherwise noted)

PARAMETER		TEST CONDITIONS	MIN	TYP	MAX	UNIT
$V_{PWM,H}$	High-level PWM voltage		2.6			V
$V_{PWM,L}$	Low-level PWM voltage				0.7	V
$I_{PWM,H}$	High-level PWM input current	$V_{PWM} = 5\text{ V}$		220	500	μA
$I_{PWM,L}$	Low-level PWM input current	$V_{PWM} = 0\text{ V}$	-1		1	μA
$t_{PWM,ON}$	Delay time, turn on	70% of I_{Qnom} , See Figure 6	0	15	40	μs
$t_{PWM,OFF}$	Delay time, turn off	30% of I_{Qnom} , See Figure 6	0	15	40	μs

REFERENCE (REF) ELECTRICAL CHARACTERISTICS

over recommended operating free-air temperature range, $V_I = 13.5\text{ V}$, $R_{REF} = 0.47\ \Omega$, $V_{PWM,H}$, $T_J = -40^\circ\text{C}$ to 150°C , all voltages with respect to ground (unless otherwise noted)

PARAMETER		TEST CONDITIONS	MIN	TYP	MAX	UNIT
V_{REF}	Reference voltage	$R_{REF} = 0.39\ \Omega$ to $1\ \Omega$	168	177	185	mV
I_{REF}	Reference input current	$V_{REF} = 180\text{ mV}$	-1	0.1	1	μA

STATUS OUTPUT (ST) ELECTRICAL CHARACTERISTICS

over recommended operating free-air temperature range, $V_I = 13.5\text{ V}$, $R_{REF} = 0.47\ \Omega$, $V_{PWM,H}$, $T_J = -40^\circ\text{C}$ to 150°C , all voltages with respect to ground (unless otherwise noted)

PARAMETER		TEST CONDITIONS	MIN	TYP	MAX	UNIT
V_{IQL}	Lower status-switching threshold	ST = L	15	25		mV
V_{IQH}	Upper status-switching threshold	ST = H		30	40	mV
V_{STL}	Low-level status voltage	$I_{ST} = 1.5\text{ mA}$			0.4	V
I_{STLK}	Leakage current	$V_{ST} = 5\text{ V}$			5	μA

STATUS DELAY (D) ELECTRICAL CHARACTERISTICS

over recommended operating free-air temperature range, $V_I = 13.5\text{ V}$, $R_{REF} = 0.47\ \Omega$, $V_{PWM,H}$, $T_J = -40^\circ\text{C}$ to 150°C , all voltages with respect to ground (unless otherwise noted)

PARAMETER		TEST CONDITIONS	MIN	TYP	MAX	UNIT
t_{STHL}	Delay time, status reaction	$C_D = 47\text{ nF}$, ST H→L	6	10	14	ms
t_{STLH}	Delay time, status release	$C_D = 47\text{ nF}$, ST L→H		10	20	μs

TYPICAL CHARACTERISTICS

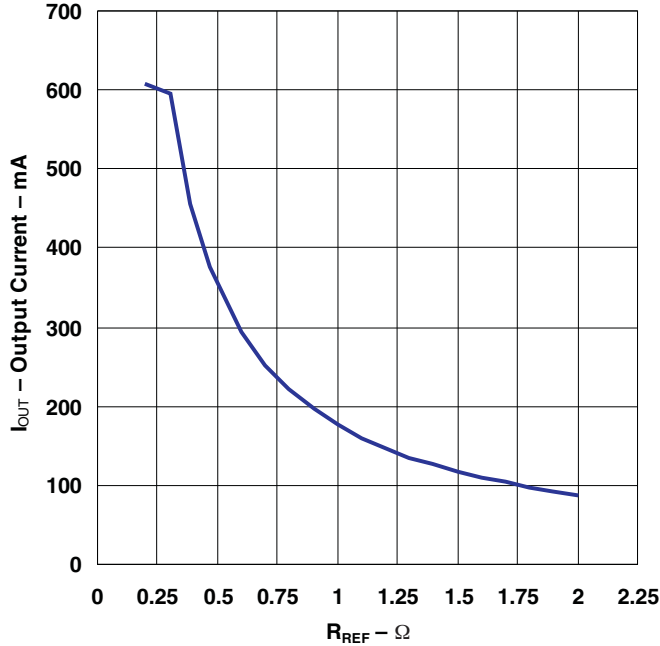

Figure 1. Output Current vs External Resistor

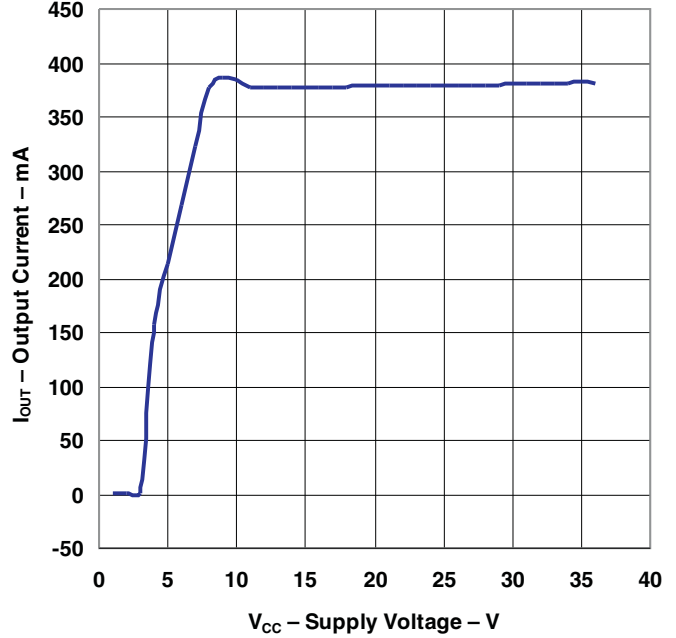

Figure 2. Output Current vs Supply Voltage

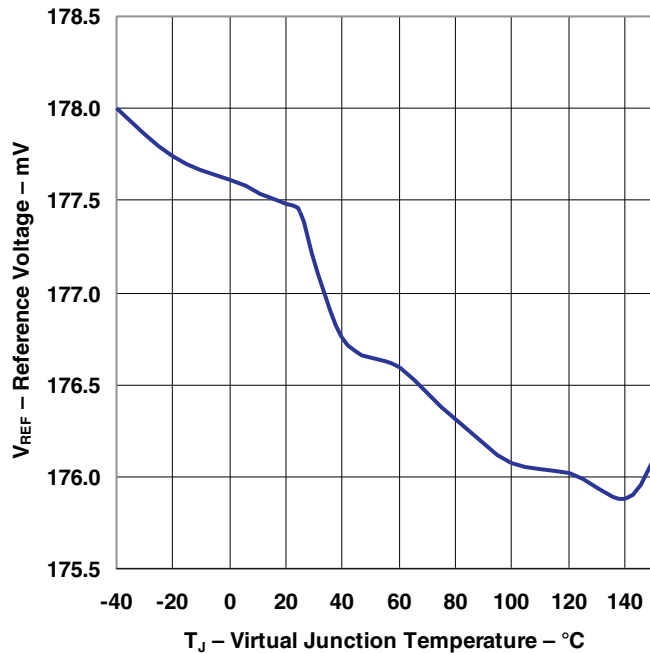

Figure 3. Reference Voltage vs Junction Temperature

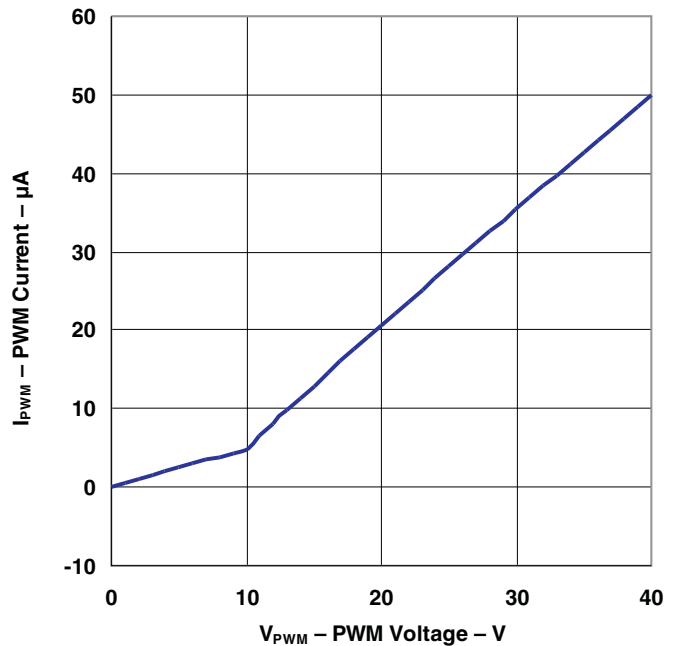

Figure 4. PWM Pin Input Current vs PWM Voltage

APPLICATION INFORMATION

Figure 5 shows a typical application with the TL4242 LED driver. The three LEDs are driven by a supply current that is adjusted by the resistor, R_{REF} , preventing brightness variations due to forward voltage spread of the LEDs. The luminosity spread arising from the LED production process can be compensated via software by an appropriate duty cycle applied to the PWM pin. Therefore, it is not necessary to select LEDs for forward voltage or luminosity classes. The minimum supply voltage calculates as the sum of the LED forward voltages, the TL4242 drop voltage (maximum 0.7 V at a LED current of 300 mA) and the maximum voltage drop at the shunt resistor R_{REF} of 185 mV (max).

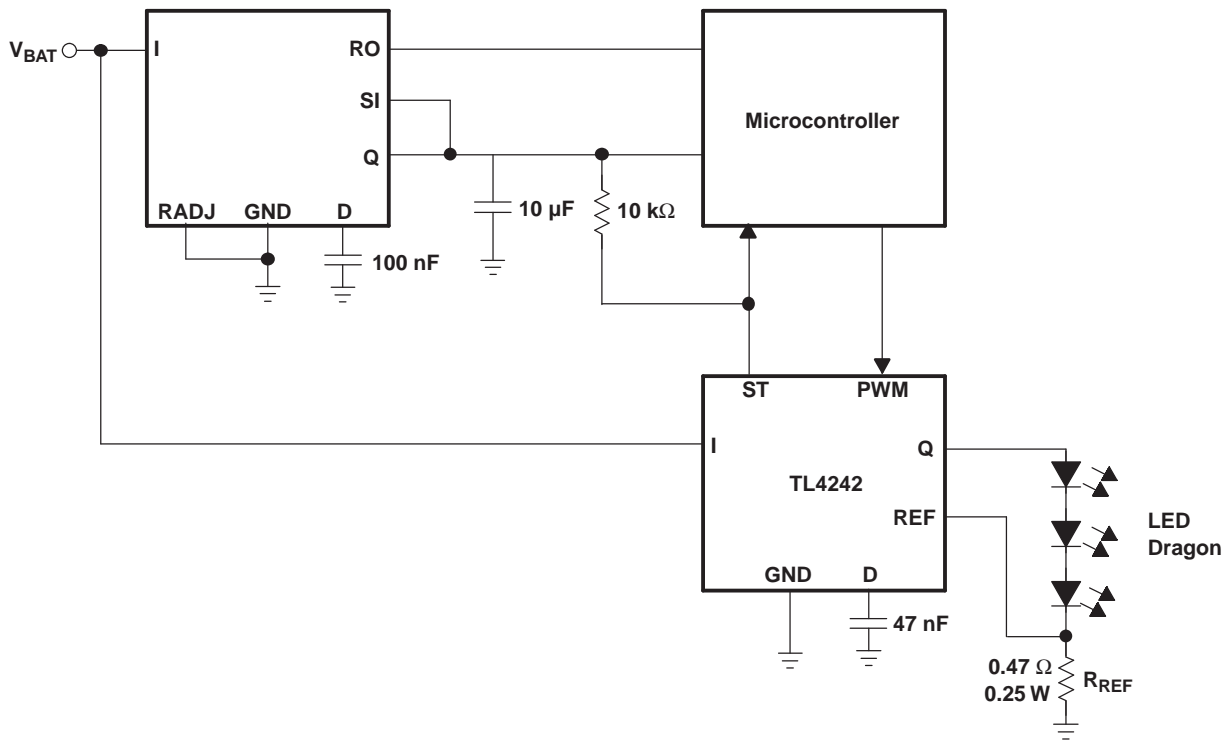

Figure 5. Application Circuit

The status output of the LED driver (ST) detects an open-load condition, enabling supervision of correct LED operation. An LED failure is detected as a voltage drop at the shunt resistor (R_{REF}) below 25 mV (typ). In this case, the status output pin (ST) is set low after a delay time adjustable by an optional capacitor connected to pin D.

The functionality and timing of ST and PWM are shown in Figure 6. The status delay can be adjusted via the capacitor connected to pin D. Delay time scales linearly with capacitance, C_D :

$$t_{STHL,typ} = \frac{C_D}{47 \text{ nF}} \times 10 \text{ ms}$$

$$t_{STLH,typ} = \frac{C_D}{47 \text{ nF}} \times 10 \text{ }\mu\text{s}$$

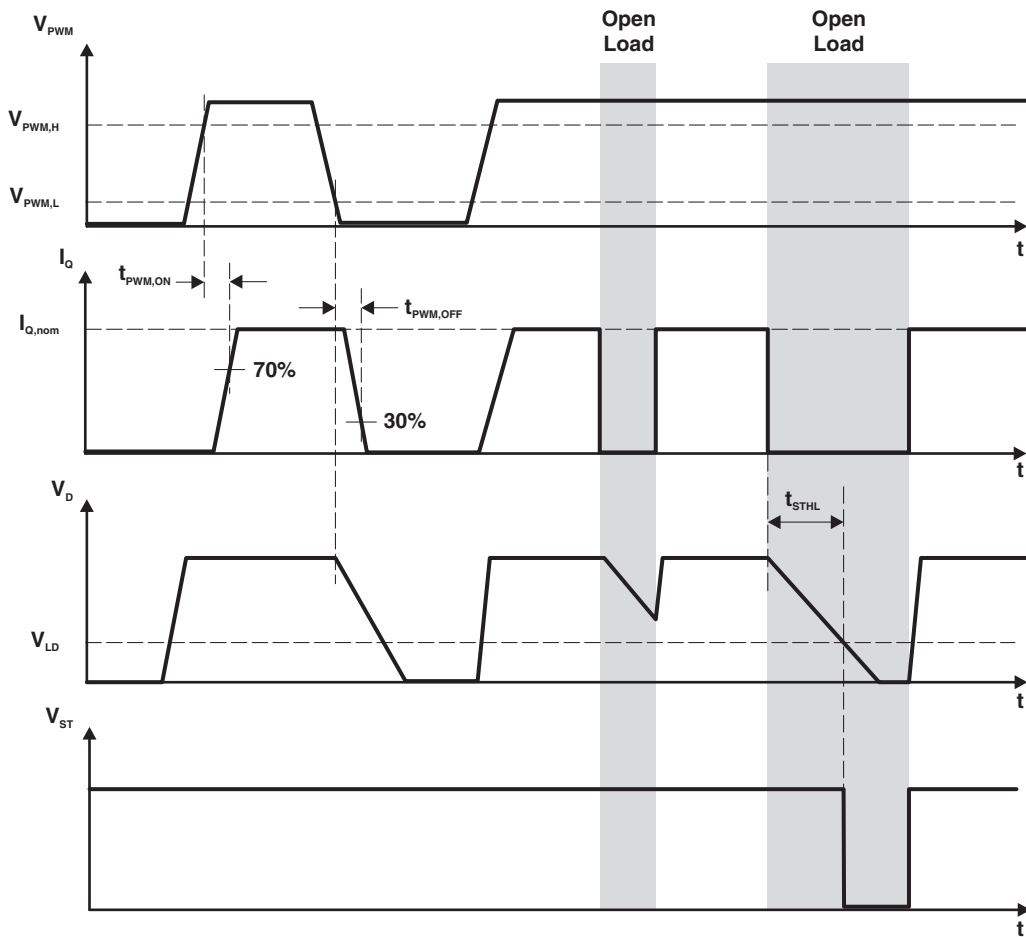

Figure 6. Function and Timing Diagram

PACKAGING INFORMATION

Orderable Device	Status ⁽¹⁾	Package Type	Package Drawing	Pins	Package Qty	Eco Plan ⁽²⁾	Lead/Ball Finish	MSL Peak Temp ⁽³⁾
TL4242DRJR	ACTIVE	SON	DRJ	8	1000	Green (RoHS & no Sb/Br)	CU NIPDAU	Level-3-260C-168 HR

⁽¹⁾ The marketing status values are defined as follows:

ACTIVE: Product device recommended for new designs.

LIFEBUY: TI has announced that the device will be discontinued, and a lifetime-buy period is in effect.

NRND: Not recommended for new designs. Device is in production to support existing customers, but TI does not recommend using this part in a new design.

PREVIEW: Device has been announced but is not in production. Samples may or may not be available.

OBSELETE: TI has discontinued the production of the device.

⁽²⁾ Eco Plan - The planned eco-friendly classification: Pb-Free (RoHS), Pb-Free (RoHS Exempt), or Green (RoHS & no Sb/Br) - please check <http://www.ti.com/productcontent> for the latest availability information and additional product content details.

TBD: The Pb-Free/Green conversion plan has not been defined.

Pb-Free (RoHS): TI's terms "Lead-Free" or "Pb-Free" mean semiconductor products that are compatible with the current RoHS requirements for all 6 substances, including the requirement that lead not exceed 0.1% by weight in homogeneous materials. Where designed to be soldered at high temperatures, TI Pb-Free products are suitable for use in specified lead-free processes.

Pb-Free (RoHS Exempt): This component has a RoHS exemption for either 1) lead-based flip-chip solder bumps used between the die and package, or 2) lead-based die adhesive used between the die and leadframe. The component is otherwise considered Pb-Free (RoHS compatible) as defined above.

Green (RoHS & no Sb/Br): TI defines "Green" to mean Pb-Free (RoHS compatible), and free of Bromine (Br) and Antimony (Sb) based flame retardants (Br or Sb do not exceed 0.1% by weight in homogeneous material)

⁽³⁾ MSL, Peak Temp. -- The Moisture Sensitivity Level rating according to the JEDEC industry standard classifications, and peak solder temperature.

Important Information and Disclaimer:The information provided on this page represents TI's knowledge and belief as of the date that it is provided. TI bases its knowledge and belief on information provided by third parties, and makes no representation or warranty as to the accuracy of such information. Efforts are underway to better integrate information from third parties. TI has taken and continues to take reasonable steps to provide representative and accurate information but may not have conducted destructive testing or chemical analysis on incoming materials and chemicals. TI and TI suppliers consider certain information to be proprietary, and thus CAS numbers and other limited information may not be available for release.

In no event shall TI's liability arising out of such information exceed the total purchase price of the TI part(s) at issue in this document sold by TI to Customer on an annual basis.

TAPE AND REEL INFORMATION

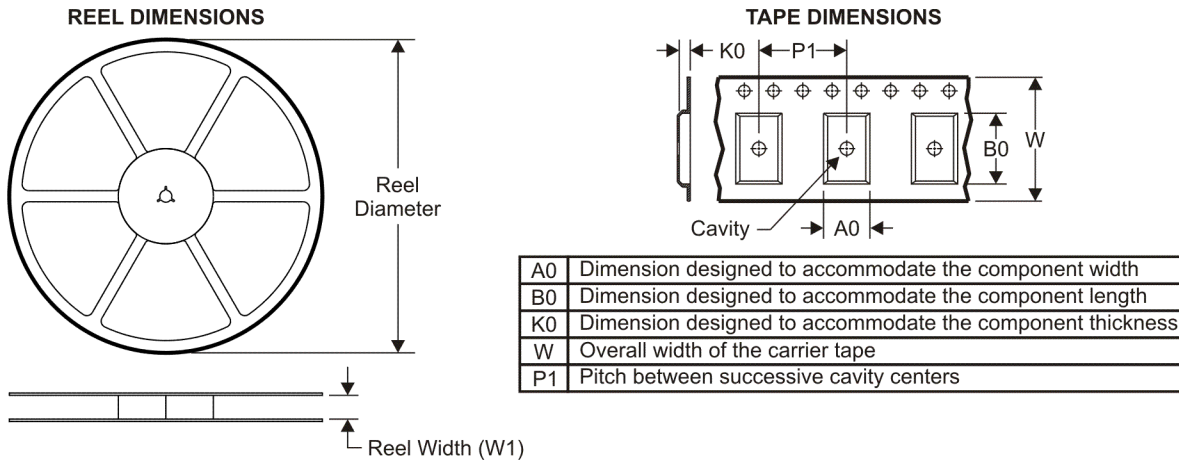

QUADRANT ASSIGNMENTS FOR PIN 1 ORIENTATION IN TAPE

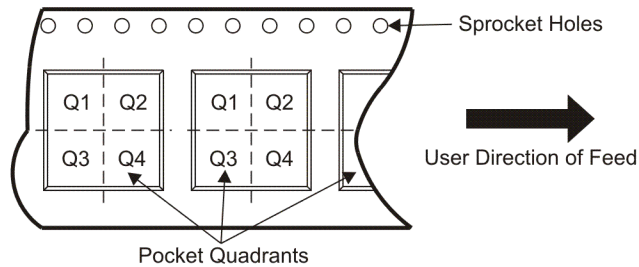

*All dimensions are nominal

Device	Package Type	Package Drawing	Pins	SPQ	Reel Diameter (mm)	Reel Width W1 (mm)	A0 (mm)	B0 (mm)	K0 (mm)	P1 (mm)	W (mm)	Pin1 Quadrant
TL4242DRJR	SON	DRJ	8	1000	180.0	12.4	4.3	4.3	1.5	8.0	12.0	Q2

TAPE AND REEL BOX DIMENSIONS

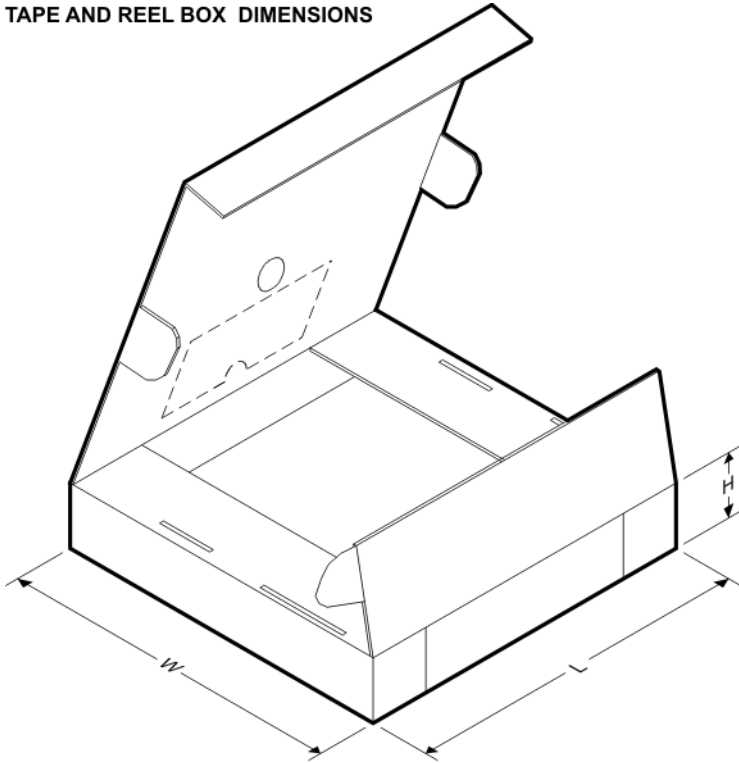

*All dimensions are nominal

Device	Package Type	Package Drawing	Pins	SPQ	Length (mm)	Width (mm)	Height (mm)
TL4242DRJR	SON	DRJ	8	1000	190.5	212.7	31.8

MECHANICAL DATA

DRJ (S-PDSO-N8)

PLASTIC SMALL OUTLINE

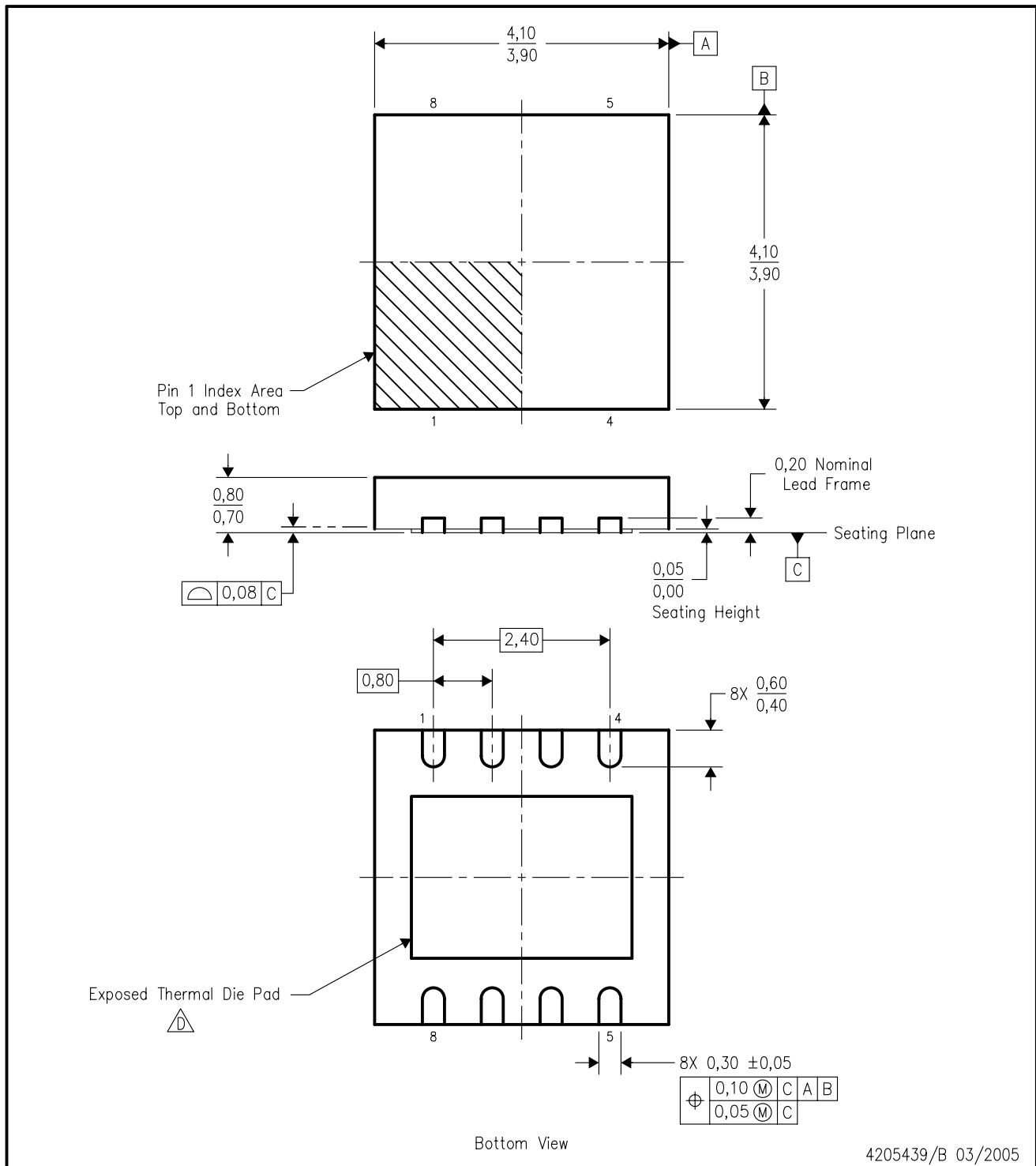

4205439/B 03/2005

- NOTES:
- A. All linear dimensions are in millimeters. Dimensioning and tolerancing per ASME Y14.5M-1994.
 - B. This drawing is subject to change without notice.
 - C. SON (Small Outline No-Lead) package configuration.
 - D. The package thermal pad must be soldered to the board for thermal and mechanical performance. See the Product Data Sheet for details regarding the exposed thermal pad dimensions.
 - E. Package complies to JEDEC MO-229 variation WGGB.

THERMAL INFORMATION

This package incorporates an exposed thermal pad that is designed to be attached directly to an external heatsink. The thermal pad must be soldered directly to the printed circuit board (PCB). After soldering, the PCB can be used as a heatsink. In addition, through the use of thermal vias, the thermal pad can be attached directly to the appropriate copper plane shown in the electrical schematic for the device, or alternatively, can be attached to a special heatsink structure designed into the PCB. This design optimizes the heat transfer from the integrated circuit (IC).

For information on the Quad Flatpack No-Lead (QFN) package and its advantages, refer to Application Report, Quad Flatpack No-Lead Logic Packages, Texas Instruments Literature No. SCBA017. This document is available at www.ti.com.

The exposed thermal pad dimensions for this package are shown in the following illustration.

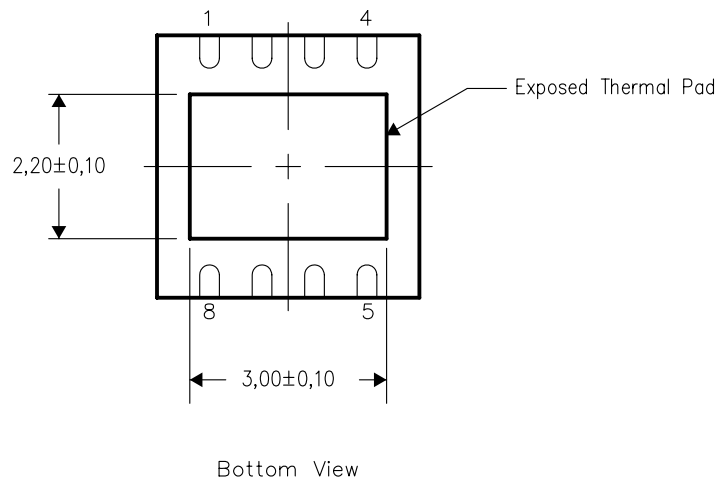

NOTE: All linear dimensions are in millimeters

Exposed Thermal Pad Dimensions

DRJ (S-PDSO-N8)

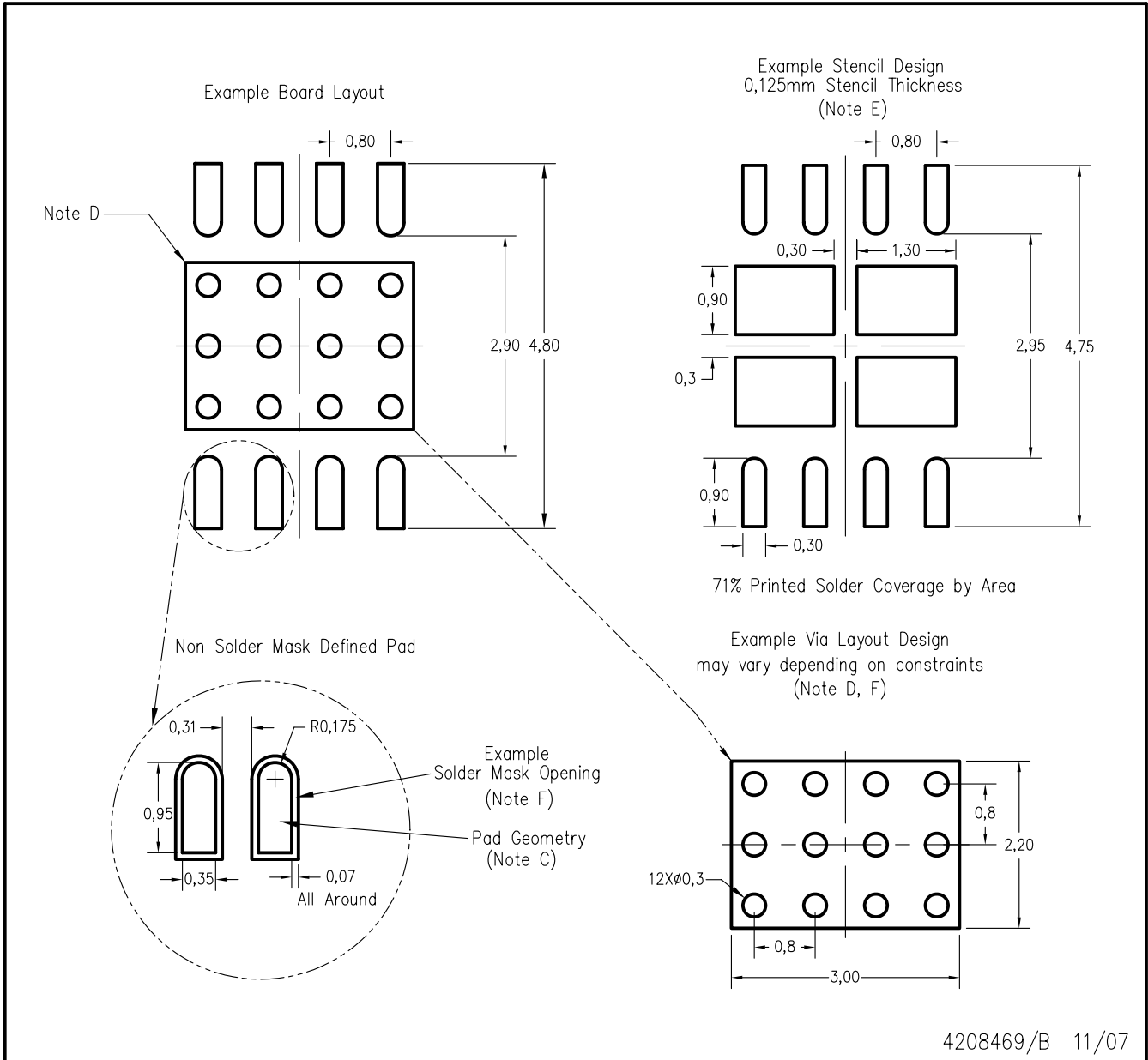

- NOTES:
- A. All linear dimensions are in millimeters.
 - B. This drawing is subject to change without notice.
 - C. Publication IPC-7351 is recommended for alternate designs.
 - D. This package is designed to be soldered to a thermal pad on the board. Refer to Application Note, Quad Flat-Pack Packages, Texas Instruments Literature No. SCBA017, SLUA271, and also the Product Data Sheets for specific thermal information, via requirements, and recommended board layout. These documents are available at www.ti.com <<http://www.ti.com>>.
 - E. Laser cutting apertures with electropolish and also rounding corners will offer better paste release. Customers should contact their board assembly site for stencil design recommendations. Refer to IPC 7525 for stencil design considerations.
 - F. Customers should contact their board fabrication site for solder mask tolerances and vias tenting recommendations for vias placed in the thermal pad.

IMPORTANT NOTICE

Texas Instruments Incorporated and its subsidiaries (TI) reserve the right to make corrections, modifications, enhancements, improvements, and other changes to its products and services at any time and to discontinue any product or service without notice. Customers should obtain the latest relevant information before placing orders and should verify that such information is current and complete. All products are sold subject to TI's terms and conditions of sale supplied at the time of order acknowledgment.

TI warrants performance of its hardware products to the specifications applicable at the time of sale in accordance with TI's standard warranty. Testing and other quality control techniques are used to the extent TI deems necessary to support this warranty. Except where mandated by government requirements, testing of all parameters of each product is not necessarily performed.

TI assumes no liability for applications assistance or customer product design. Customers are responsible for their products and applications using TI components. To minimize the risks associated with customer products and applications, customers should provide adequate design and operating safeguards.

TI does not warrant or represent that any license, either express or implied, is granted under any TI patent right, copyright, mask work right, or other TI intellectual property right relating to any combination, machine, or process in which TI products or services are used. Information published by TI regarding third-party products or services does not constitute a license from TI to use such products or services or a warranty or endorsement thereof. Use of such information may require a license from a third party under the patents or other intellectual property of the third party, or a license from TI under the patents or other intellectual property of TI.

Reproduction of TI information in TI data books or data sheets is permissible only if reproduction is without alteration and is accompanied by all associated warranties, conditions, limitations, and notices. Reproduction of this information with alteration is an unfair and deceptive business practice. TI is not responsible or liable for such altered documentation. Information of third parties may be subject to additional restrictions.

Resale of TI products or services with statements different from or beyond the parameters stated by TI for that product or service voids all express and any implied warranties for the associated TI product or service and is an unfair and deceptive business practice. TI is not responsible or liable for any such statements.

TI products are not authorized for use in safety-critical applications (such as life support) where a failure of the TI product would reasonably be expected to cause severe personal injury or death, unless officers of the parties have executed an agreement specifically governing such use. Buyers represent that they have all necessary expertise in the safety and regulatory ramifications of their applications, and acknowledge and agree that they are solely responsible for all legal, regulatory and safety-related requirements concerning their products and any use of TI products in such safety-critical applications, notwithstanding any applications-related information or support that may be provided by TI. Further, Buyers must fully indemnify TI and its representatives against any damages arising out of the use of TI products in such safety-critical applications.

TI products are neither designed nor intended for use in military/aerospace applications or environments unless the TI products are specifically designated by TI as military-grade or "enhanced plastic." Only products designated by TI as military-grade meet military specifications. Buyers acknowledge and agree that any such use of TI products which TI has not designated as military-grade is solely at the Buyer's risk, and that they are solely responsible for compliance with all legal and regulatory requirements in connection with such use.

TI products are neither designed nor intended for use in automotive applications or environments unless the specific TI products are designated by TI as compliant with ISO/TS 16949 requirements. Buyers acknowledge and agree that, if they use any non-designated products in automotive applications, TI will not be responsible for any failure to meet such requirements.

Following are URLs where you can obtain information on other Texas Instruments products and application solutions:

Products		Applications	
Amplifiers	amplifier.ti.com	Audio	www.ti.com/audio
Data Converters	dataconverter.ti.com	Automotive	www.ti.com/automotive
DSP	dsp.ti.com	Broadband	www.ti.com/broadband
Clocks and Timers	www.ti.com/clocks	Digital Control	www.ti.com/digitalcontrol
Interface	interface.ti.com	Medical	www.ti.com/medical
Logic	logic.ti.com	Military	www.ti.com/military
Power Mgmt	power.ti.com	Optical Networking	www.ti.com/opticalnetwork
Microcontrollers	microcontroller.ti.com	Security	www.ti.com/security
RFID	www.ti-rfid.com	Telephony	www.ti.com/telephony
RF/IF and ZigBee® Solutions	www.ti.com/lprf	Video & Imaging	www.ti.com/video
		Wireless	www.ti.com/wireless

Mailing Address: Texas Instruments, Post Office Box 655303, Dallas, Texas 75265
Copyright © 2008, Texas Instruments Incorporated