

SUPPLY-VOLTAGE SUPERVISOR

SLVS220C – JULY 1999 – REVISED NOVEMBER 2004

- **Adjustable Sense Voltage With Two External Resistors**
- **Adjustable Hysteresis of Sense Voltage**
- **Wide Operating Supply-Voltage Range . . . 1.8 V to 40 V**
- **Wide Operating Temperature Range . . . -40°C to 85°C**
- **Low Power Consumption ($I_{CC} = 0.6 \text{ mA}$ TYP, $V_{CC} = 40 \text{ V}$)**
- **Minimum External Components**

P, PS, OR PW PACKAGE
(TOP VIEW)

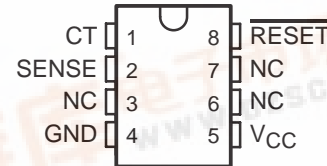

NC – No internal connection

description/ordering information

The TL7700 is a bipolar integrated circuit designed for use as a reset controller in microcomputer and microprocessor systems. The SENSE voltage can be set to any value greater than 0.5 V using two external resistors. The hysteresis value of the sense voltage also can be set by the same resistors. The device includes a precision voltage reference, fast comparator, timing generator, and output driver, so it can generate a power-on reset signal in a digital system.

The TL7700 has an internal 1.5-V temperature-compensated voltage reference from which all function blocks are supplied. Circuit function is very stable, with supply voltage in the 1.8-V to 40-V range. Minimum supply current allows use with ac line operation, portable battery operation, and automotive applications.

ORDERING INFORMATION

T _A	PACKAGE†		ORDERABLE PART NUMBER	TOP-SIDE MARKING
-40°C to 85°C	PDIP (P)	Tube of 50	TL7700CP	TL7700CP
	SOP (PS)	Reel of 2000	TL7700CPSR	T7700
	TSSOP (PW)	Tube of 150	TL7700CPW	T7700
		Reel of 2000	TL7700CPWR	

† Package drawings, standard packing quantities, thermal data, symbolization, and PCB design guidelines are available at www.ti.com/sc/package.

Please be aware that an important notice concerning availability, standard warranty, and use in critical applications of Texas Instruments semiconductor products and disclaimers thereto appears at the end of this data sheet.

TL7700 SUPPLY-VOLTAGE SUPERVISOR

SLVS220C – JULY 1999 – REVISED NOVEMBER 2004

functional block diagram

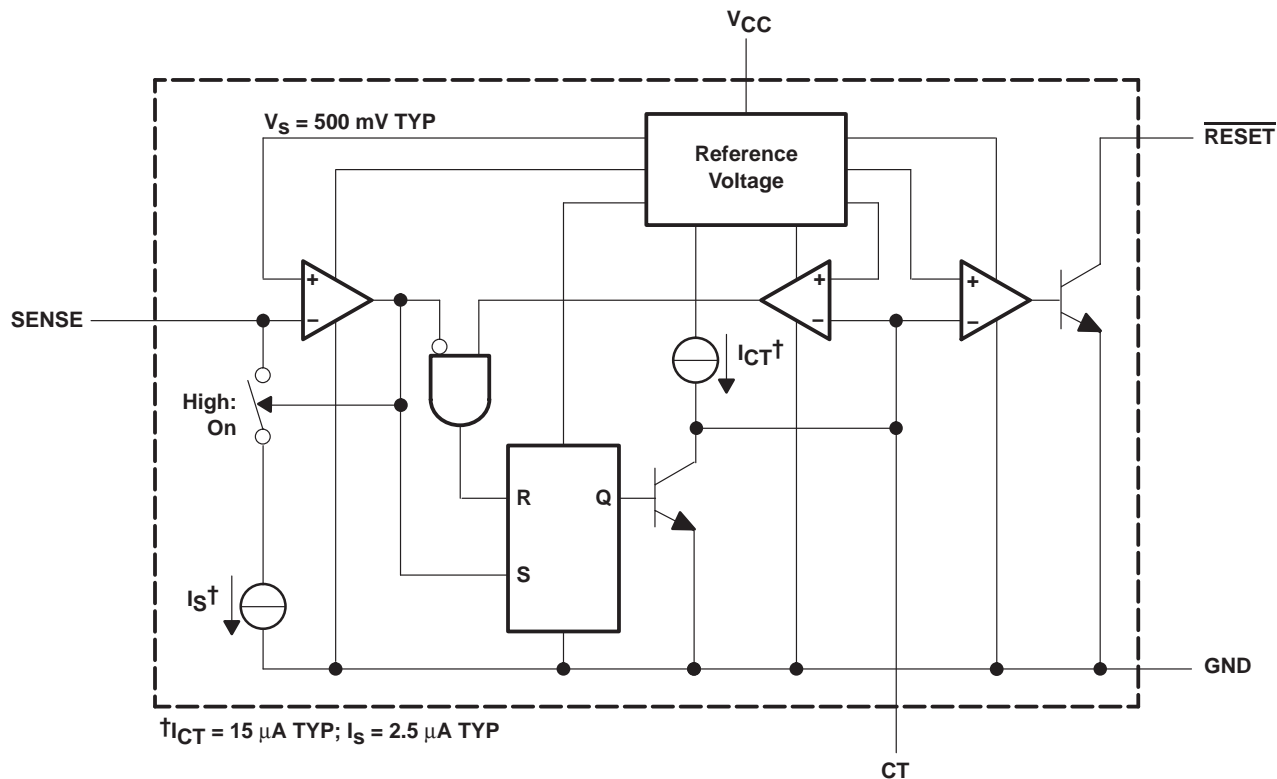

Terminal Functions

TERMINAL NAME	NO.	DESCRIPTION
CT	1	Timing capacitor connection. This terminal sets the $\overline{\text{RESET}}$ output pulse duration (t_{PO}). It is connected internally to a 15- μA constant-current source. There is a limit on the switching speed of internal elements; even if CT is set to 0, response speeds remain at approximately 5 to 10 μs . If CT is open, the device can be used as an adjustable-threshold noninverting comparator. If CT is low, the internal output-stage comparator is active, and the $\overline{\text{RESET}}$ output transistor is on. An external voltage must not be applied to this terminal due to the internal structure of the device. Therefore, drive the device using an open-collector transistor, FET, or 3-state buffer (in the low-level or high-impedance state).
GND	4	Ground. Keep this terminal as low impedance to reduce circuit noise.
NC	3, 6, 7	No internal connection
$\overline{\text{RESET}}$	8	Reset output. This terminal can be connected directly to a system that resets in the active-low state. A pullup resistor usually is required because the output is an npn open-collector transistor. An additional transistor should be connected when the active-high reset or higher output current is required.
SENSE	2	Voltage sense. This terminal has a threshold level of 500 mV. The sense voltage and hysteresis can be set at the same time when the two voltage-dividing resistors are connected. The reference voltage is temperature compensated to inhibit temperature drift in the threshold voltage within the operating temperature range.
VCC	5	Power supply. This terminal is used in an operating-voltage range of 1.8 V to 40 V.

TL7700 SUPPLY-VOLTAGE SUPERVISOR

SLVS220C – JULY 1999 – REVISED NOVEMBER 2004

absolute maximum ratings over operating free-air temperature range (unless otherwise noted)†

Supply voltage, V_{CC} (see Note 1)	41 V
Sense input voltage range, V_S	–0.3 V to 41 V
Output voltage, V_{OH} (off state)	41 V
Output current, I_{OL} (on state)	5 mA
Package thermal impedance, θ_{JA} (see Notes 2 and 3): P package	85°C/W
PS package	95°C/W
PW package	149°C/W
Operating virtual junction temperature, T_J	150°C
Storage temperature range, T_{stg}	–65°C to 150°C

† Stresses beyond those listed under “absolute maximum ratings” may cause permanent damage to the device. These are stress ratings only, and functional operation of the device at these or any other conditions beyond those indicated under “recommended operating conditions” is not implied. Exposure to absolute-maximum-rated conditions for extended periods may affect device reliability.

- NOTES:
1. All voltage values are with respect to the network ground terminal.
 2. Maximum power dissipation is a function of $T_J(\text{max})$, θ_{JA} , and T_A . The maximum allowable power dissipation at any allowable ambient temperature is $P_D = (T_J(\text{max}) - T_A)/\theta_{JA}$. Operating at the absolute maximum T_J of 150°C can impact reliability.
 3. The package thermal impedance is calculated in accordance with JESD 51-7.

recommended operating conditions

	MIN	MAX	UNIT
V_{CC} Supply voltage	1.8	40	V
I_{OL} Low-level output current		3	mA
T_A Operating free-air temperature	–40	85	°C

electrical characteristics, $V_{CC} = 3\text{ V}$, $T_A = 25^\circ\text{C}$ (unless otherwise noted)

PARAMETER	TEST CONDITIONS	MIN	TYP	MAX	UNIT
V_S SENSE input voltage		495	500	505	mV
	$T_A = -40^\circ\text{C}$ to 85°C	490		510	
I_S SENSE input current	$V_S = 0.4\text{ V}$ $T_A = -40^\circ\text{C}$ to 85°C	2	2.5	3	μA
		1.5		3.5	
I_{CC} Supply current	$V_{CC} = 40\text{ V}$, $V_S = 0.6\text{ V}$, No load		0.6	1	mA
V_{OL} Low-level output voltage	$I_{OL} = 1.5\text{ mA}$			0.4	V
	$I_{OL} = 3\text{ mA}$			0.8	
I_{OH} High-level output current	$V_{OH} = 40\text{ V}$, $V_S = 0.6\text{ V}$, $T_A = -40^\circ\text{C}$ to 85°C			1	μA
I_{CT} Timing-capacitor charge current	$V_S = 0.6\text{ V}$	11	15	19	μA

switching characteristics, $V_{CC} = 3\text{ V}$, $T_A = 25^\circ\text{C}$ (unless otherwise noted)

PARAMETER	TEST CONDITIONS	MIN	TYP	MAX	UNIT
t_{pi} SENSE pulse duration	$C_T = 0.01\ \mu\text{F}$	2			μs
t_{po} Output pulse duration	$C_T = 0.01\ \mu\text{F}$	0.5	1	1.5	ms
t_r Output rise time	$C_T = 0.01\ \mu\text{F}$, $R_L = 2.2\text{ k}\Omega$, $C_L = 100\text{ pF}$			15	μs
t_f Output fall time	$C_T = 0.01\ \mu\text{F}$, $R_L = 2.2\text{ k}\Omega$, $C_L = 100\text{ pF}$			0.5	μs
t_{pd} Propagation delay time, SENSE to output	$C_T = 0.01\ \mu\text{F}$			10	μs

TL7700 SUPPLY-VOLTAGE SUPERVISOR

SLVS220C – JULY 1999 – REVISED NOVEMBER 2004

PARAMETER MEASUREMENT INFORMATION

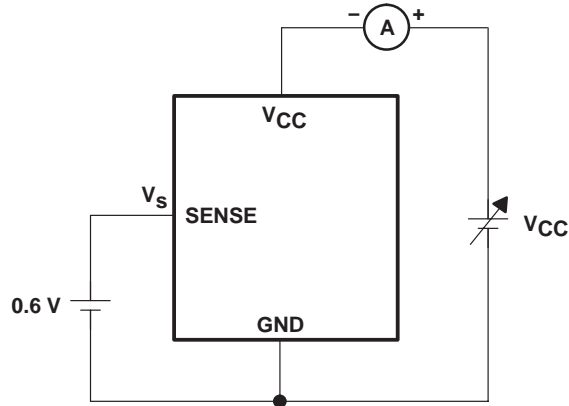

Figure 1. V_{CC} vs I_{CC} Measurement Circuit

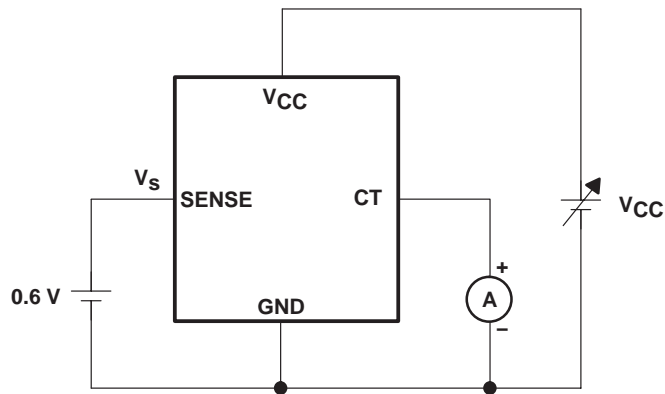

Figure 2. V_{CC} vs I_{CT}

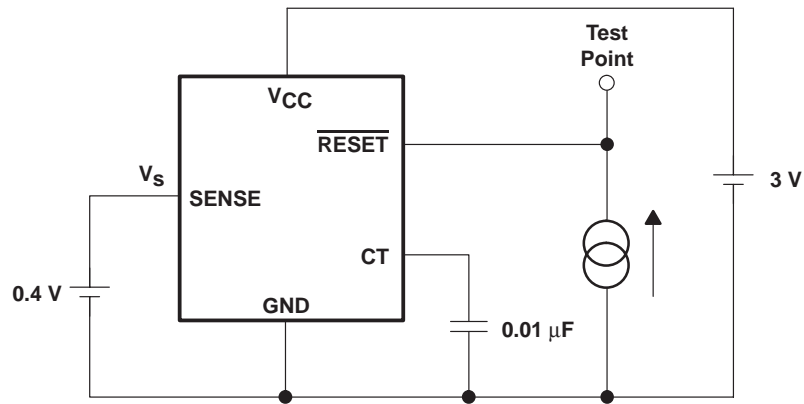

Figure 3. I_{OL} vs V_{OL}

PARAMETER MEASUREMENT INFORMATION

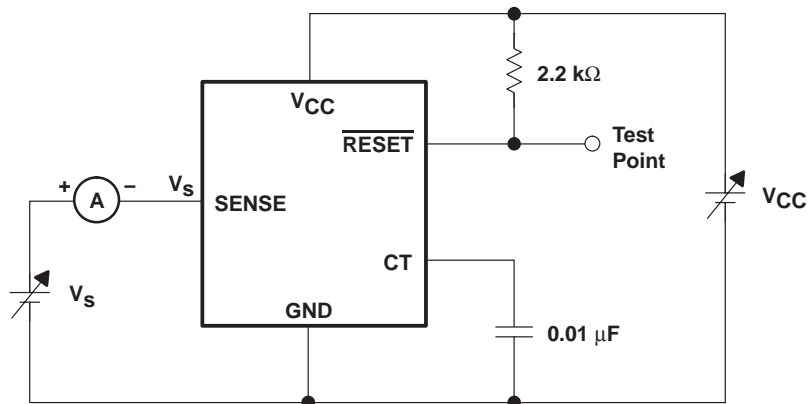

Figure 4. V_S , I_S Characteristics

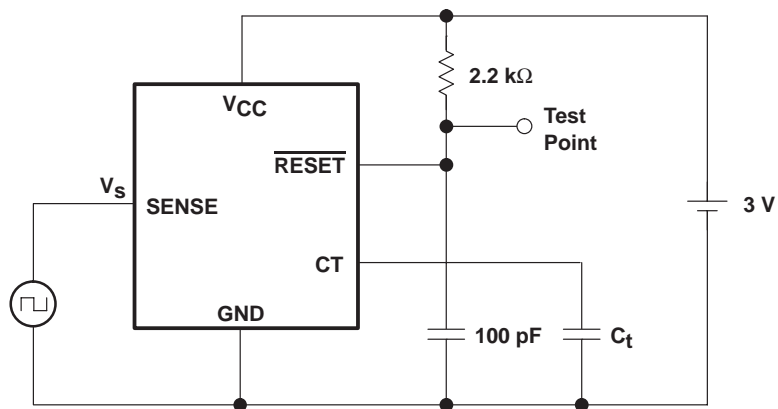

Figure 5. Switching Characteristics

TL7700 SUPPLY-VOLTAGE SUPERVISOR

SLVS220C – JULY 1999 – REVISED NOVEMBER 2004

TYPICAL CHARACTERISTICS†

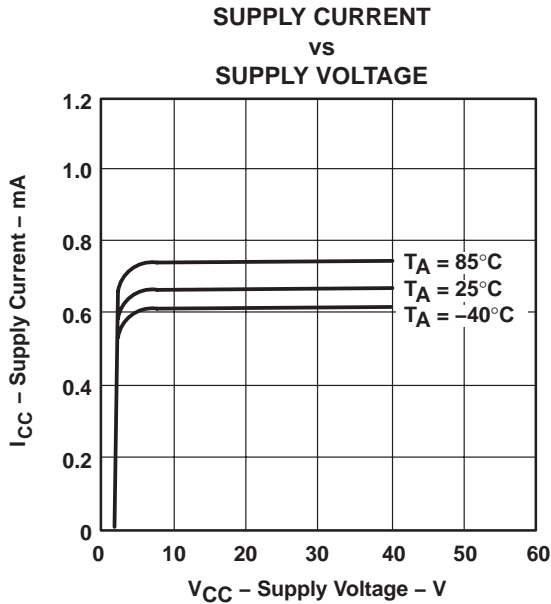

Figure 6

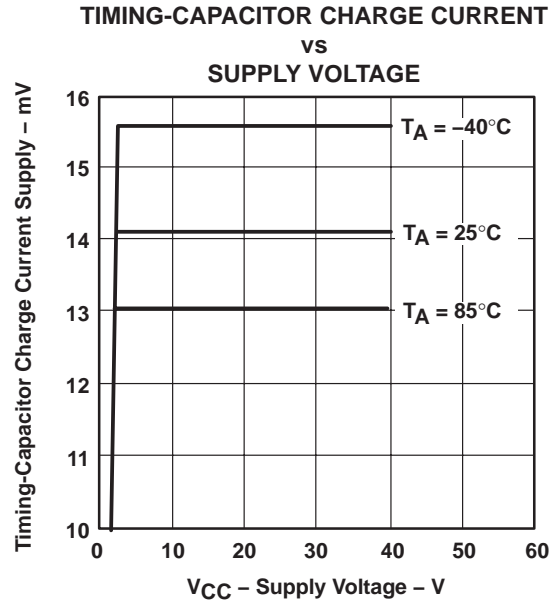

Figure 7

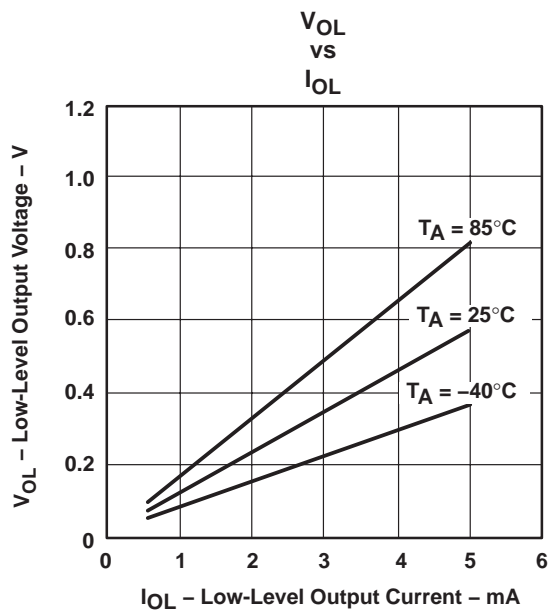

Figure 8

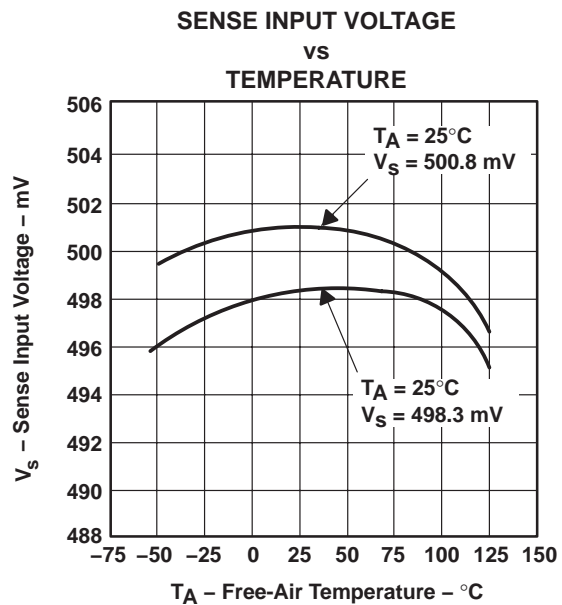

Figure 9

† Data at high and low temperatures are applicable only within the recommended operating conditions.

TYPICAL CHARACTERISTICS†

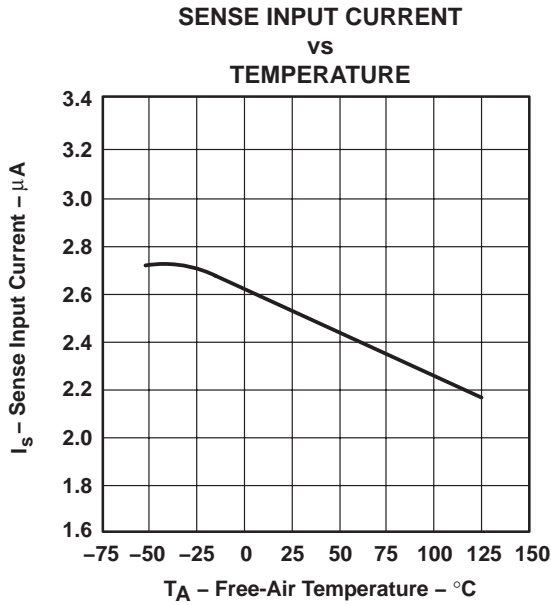

Figure 10

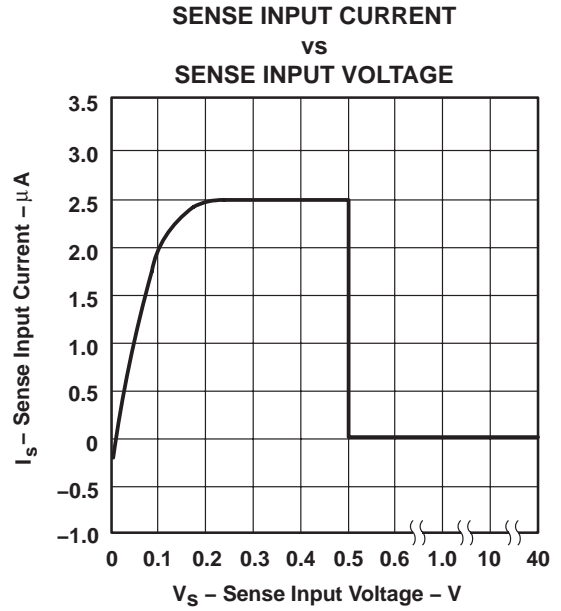

Figure 11

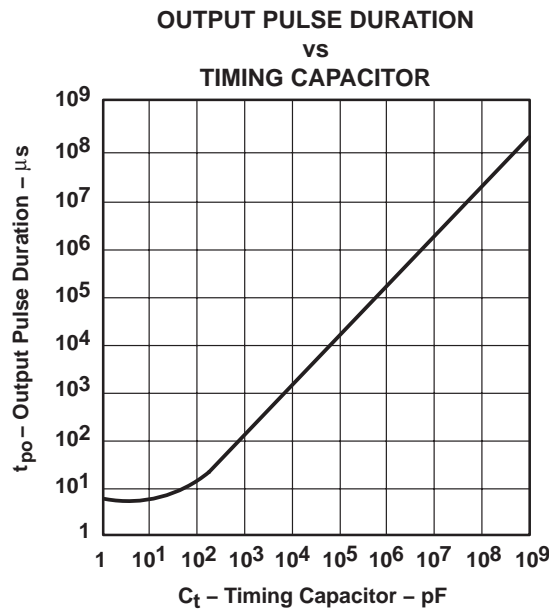

Figure 12

† Data at high and low temperatures are applicable only within the recommended operating conditions.

TL7700 SUPPLY-VOLTAGE SUPERVISOR

SLVS220C – JULY 1999 – REVISED NOVEMBER 2004

TYPICAL CHARACTERISTICS

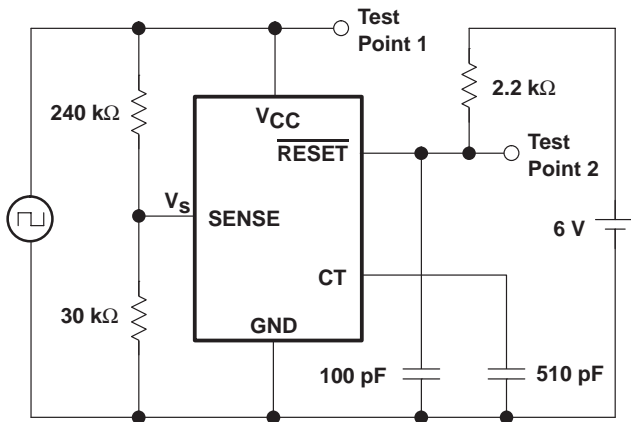

Figure 13. V_{CC} vs Output Test Circuit 1

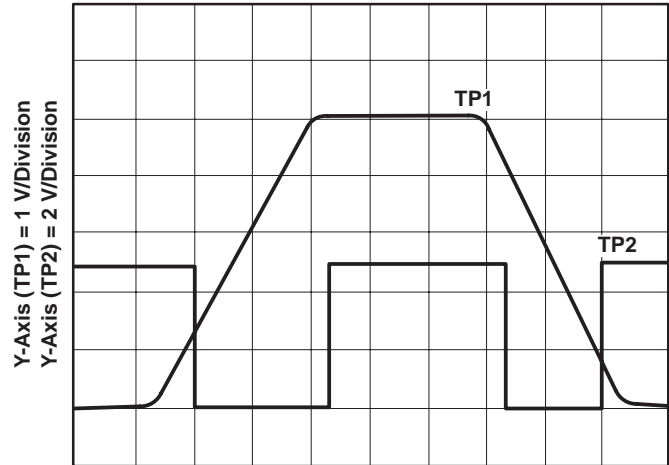

Figure 14. V_{CC} vs Output Waveform 1

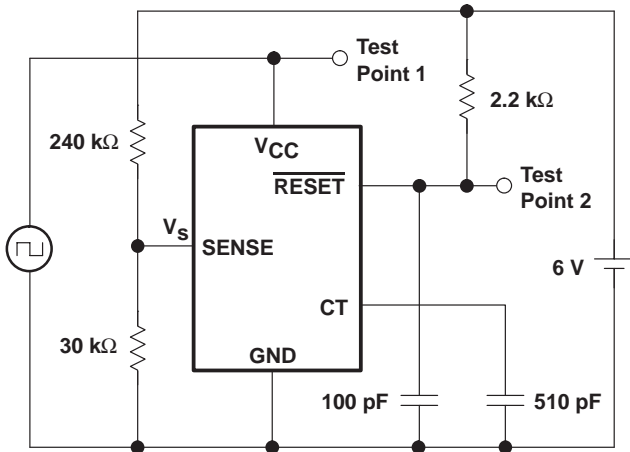

Figure 15. V_{CC} vs Output Test Circuit 2

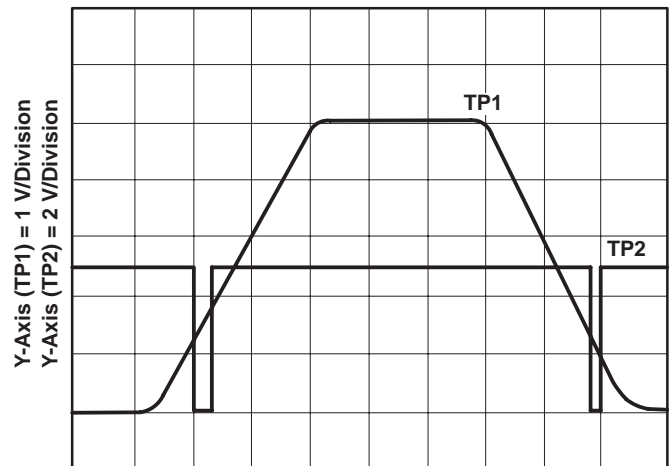

Figure 16. V_{CC} vs Output Waveform 2

TYPICAL CHARACTERISTICS

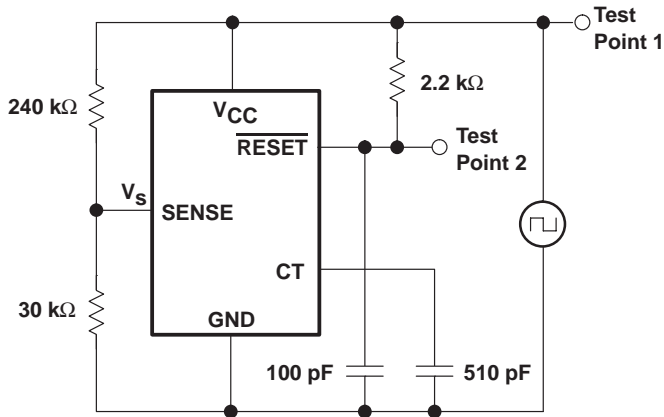

Figure 17. V_{CC} vs Output Test Circuit 3

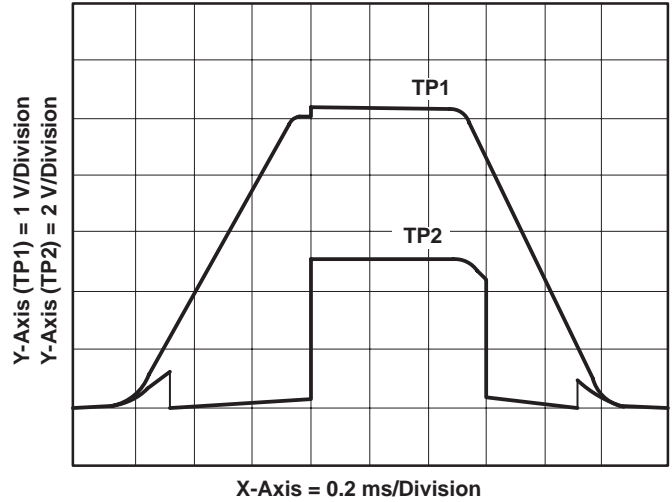

Figure 18. V_{CC} vs Output Waveform 3

detailed description

sense-voltage setting

The SENSE terminal input voltage, V_S, of the TL7700 typically is 500 mV. By using two external resistors, the circuit designer can obtain any sense voltage over 500 mV. In Figure 19, the sensing voltage, V_S', is calculated as:

$$V_{S'} = V_S \times (R1 + R2)/R2$$

Where:

$$V_S = 500 \text{ mV, typically at } T_A = 25^\circ\text{C}$$

At room temperature, V_S has a variation of 500 mV ± 5 mV. In the basic circuit shown in Figure 19, variations of [±5 × (R1 + R2)/R2] mV are superimposed on V_S.

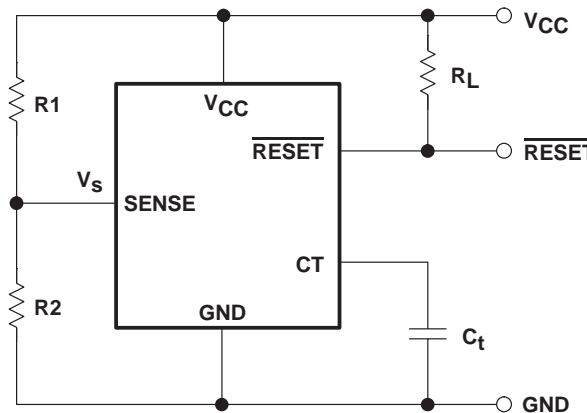

Figure 19

TL7700 SUPPLY-VOLTAGE SUPERVISOR

SLVS220C – JULY 1999 – REVISED NOVEMBER 2004

sense-voltage hysteresis setting

If the sense voltage, V_S' , does not have hysteresis in it, and the voltage on the sensing line contains ripples, the resetting of TL7700 will be unstable. Hysteresis is added to the sense voltage to prevent such problems. As shown in Figure 20, the hysteresis, V_{hys} , is added, and the value is determined as:

$$V_{hys} = I_S \times R1$$

Where:

$$I_S = 2.5 \mu A, \text{ typically at } T_A = 25^\circ C$$

At room temperature, I_S has variations of $2.5 \mu A \pm 0.5 \mu A$. Therefore, in the circuit shown in Figure 19, V_{hys} has variations of $(\pm 0.5 \times R1) \mu V$. In circuit design, it is necessary to consider the voltage-dividing resistor tolerance and temperature coefficient in addition to variations in V_S and V_{hys} .

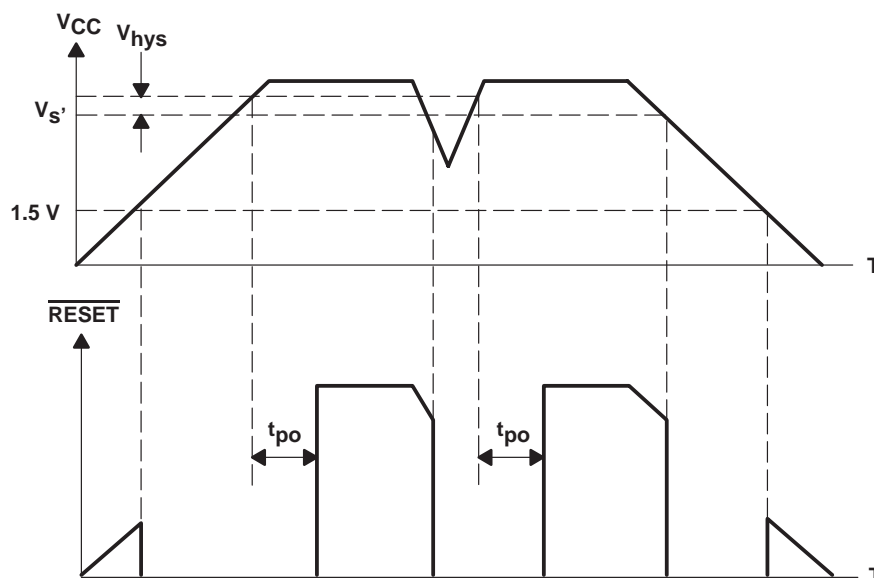

NOTE A: The sense voltage, V_S' , is different from the SENSE terminal input voltage, V_S . V_S normally is 500 mV for triggering.

Figure 20. V_{CC} -RESET Timing Chart

output pulse-duration setting

Constant-current charging starts on the timing capacitor when the sensing-line voltage reaches the TL7700 sense voltage. When the capacitor voltage exceeds the threshold level of the output drive comparator, \overline{RESET} changes from a low to a high level. The output pulse duration is the time between the point when the sense-pin voltage exceeds the threshold level and the point when the \overline{RESET} output changes from a low level to a high level. When the TL7700 is used for system power-on reset, the output pulse duration, t_{po} , must be set longer than the power rise time. The value of t_{po} is:

$$t_{po} = C_t \times 10^5 \text{ seconds}$$

Where:

C_t is the timing capacitor in farads

There is a limit on the device response speed. Even if $C_t = 0$, t_{po} is not 0, but approximately 5 μs to 10 μs . Therefore, when the TL7700 is used as a comparator with hysteresis, without connecting C_t , switching speeds (t_r/t_f , t_{po}/t_{pd} , etc.) must be considered.

PACKAGING INFORMATION

Orderable Device	Status ⁽¹⁾	Package Type	Package Drawing	Pins	Package Qty	Eco Plan ⁽²⁾	Lead/Ball Finish	MSL Peak Temp ⁽³⁾
TL7700CP	ACTIVE	PDIP	P	8	50	Pb-Free (RoHS)	CU NIPDAU	N / A for Pkg Type
TL7700CPE4	ACTIVE	PDIP	P	8	50	Pb-Free (RoHS)	CU NIPDAU	N / A for Pkg Type
TL7700CPSR	ACTIVE	SO	PS	8	2000	Green (RoHS & no Sb/Br)	CU NIPDAU	Level-1-260C-UNLIM
TL7700CPSRG4	ACTIVE	SO	PS	8	2000	Green (RoHS & no Sb/Br)	CU NIPDAU	Level-1-260C-UNLIM
TL7700CPW	ACTIVE	TSSOP	PW	8	150	Green (RoHS & no Sb/Br)	CU NIPDAU	Level-1-260C-UNLIM
TL7700CPWE4	ACTIVE	TSSOP	PW	8	150	Green (RoHS & no Sb/Br)	CU NIPDAU	Level-1-260C-UNLIM
TL7700CPWR	ACTIVE	TSSOP	PW	8	2000	Green (RoHS & no Sb/Br)	CU NIPDAU	Level-1-260C-UNLIM
TL7700CPWRE4	ACTIVE	TSSOP	PW	8	2000	Green (RoHS & no Sb/Br)	CU NIPDAU	Level-1-260C-UNLIM

⁽¹⁾ The marketing status values are defined as follows:

ACTIVE: Product device recommended for new designs.

LIFEBUY: TI has announced that the device will be discontinued, and a lifetime-buy period is in effect.

NRND: Not recommended for new designs. Device is in production to support existing customers, but TI does not recommend using this part in a new design.

PREVIEW: Device has been announced but is not in production. Samples may or may not be available.

OBSOLETE: TI has discontinued the production of the device.

⁽²⁾ Eco Plan - The planned eco-friendly classification: Pb-Free (RoHS), Pb-Free (RoHS Exempt), or Green (RoHS & no Sb/Br) - please check <http://www.ti.com/productcontent> for the latest availability information and additional product content details.

TBD: The Pb-Free/Green conversion plan has not been defined.

Pb-Free (RoHS): TI's terms "Lead-Free" or "Pb-Free" mean semiconductor products that are compatible with the current RoHS requirements for all 6 substances, including the requirement that lead not exceed 0.1% by weight in homogeneous materials. Where designed to be soldered at high temperatures, TI Pb-Free products are suitable for use in specified lead-free processes.

Pb-Free (RoHS Exempt): This component has a RoHS exemption for either 1) lead-based flip-chip solder bumps used between the die and package, or 2) lead-based die adhesive used between the die and leadframe. The component is otherwise considered Pb-Free (RoHS compatible) as defined above.

Green (RoHS & no Sb/Br): TI defines "Green" to mean Pb-Free (RoHS compatible), and free of Bromine (Br) and Antimony (Sb) based flame retardants (Br or Sb do not exceed 0.1% by weight in homogeneous material)

⁽³⁾ MSL, Peak Temp. -- The Moisture Sensitivity Level rating according to the JEDEC industry standard classifications, and peak solder temperature.

Important Information and Disclaimer:The information provided on this page represents TI's knowledge and belief as of the date that it is provided. TI bases its knowledge and belief on information provided by third parties, and makes no representation or warranty as to the accuracy of such information. Efforts are underway to better integrate information from third parties. TI has taken and continues to take reasonable steps to provide representative and accurate information but may not have conducted destructive testing or chemical analysis on incoming materials and chemicals. TI and TI suppliers consider certain information to be proprietary, and thus CAS numbers and other limited information may not be available for release.

In no event shall TI's liability arising out of such information exceed the total purchase price of the TI part(s) at issue in this document sold by TI to Customer on an annual basis.

MECHANICAL DATA

MPDI001A – JANUARY 1995 – REVISED JUNE 1999

P (R-PDIP-T8)

PLASTIC DUAL-IN-LINE

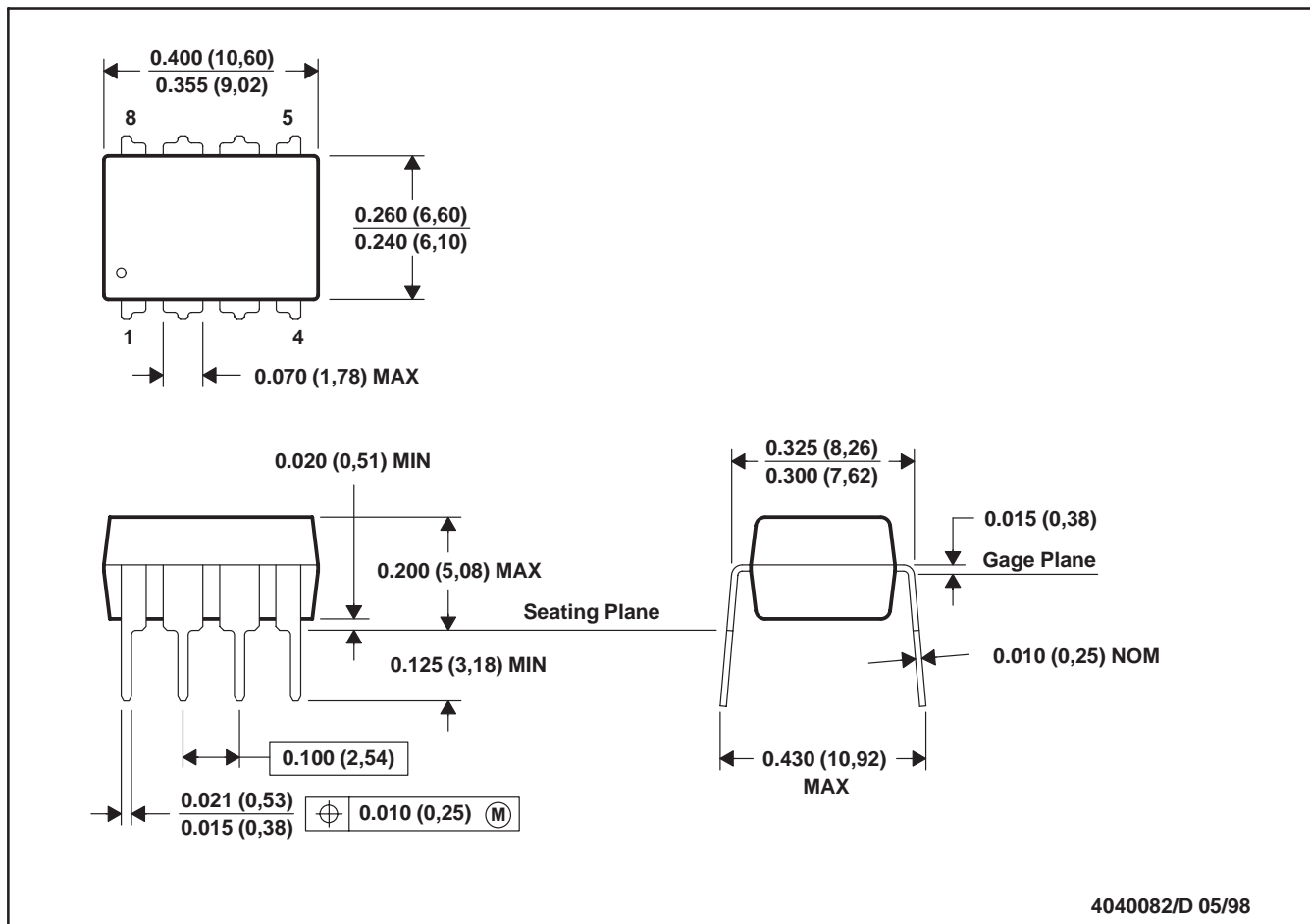

- NOTES: A. All linear dimensions are in inches (millimeters).
 B. This drawing is subject to change without notice.
 C. Falls within JEDEC MS-001

MECHANICAL DATA

PS (R-PDSO-G8)

PLASTIC SMALL-OUTLINE PACKAGE

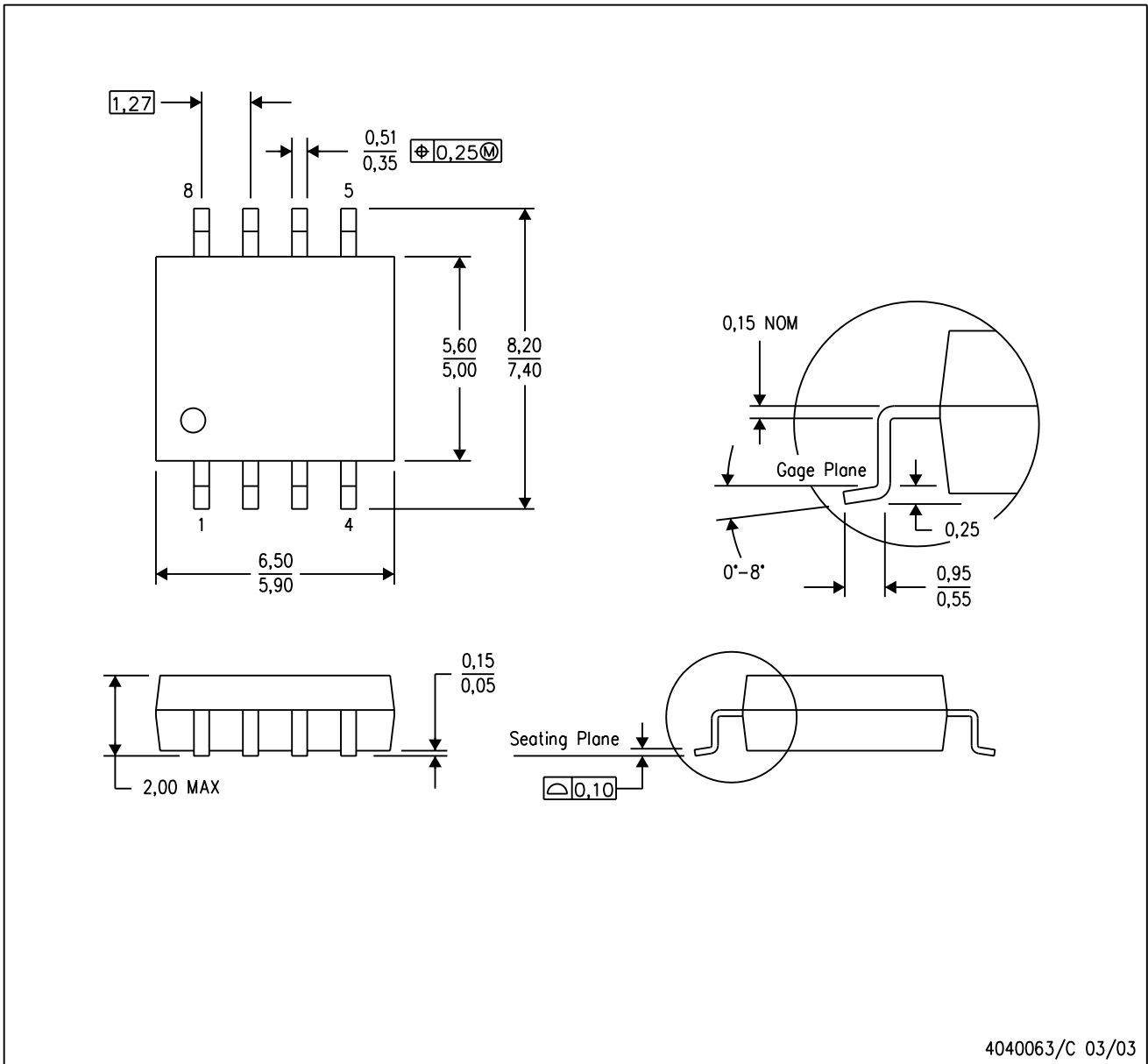

4040063/C 03/03

- NOTES:
- A. All linear dimensions are in millimeters.
 - B. This drawing is subject to change without notice.
 - C. Body dimensions do not include mold flash or protrusion, not to exceed 0,15.

MECHANICAL DATA

MTSS001C – JANUARY 1995 – REVISED FEBRUARY 1999

PW (R-PDSO-G)**

PLASTIC SMALL-OUTLINE PACKAGE

14 PINS SHOWN

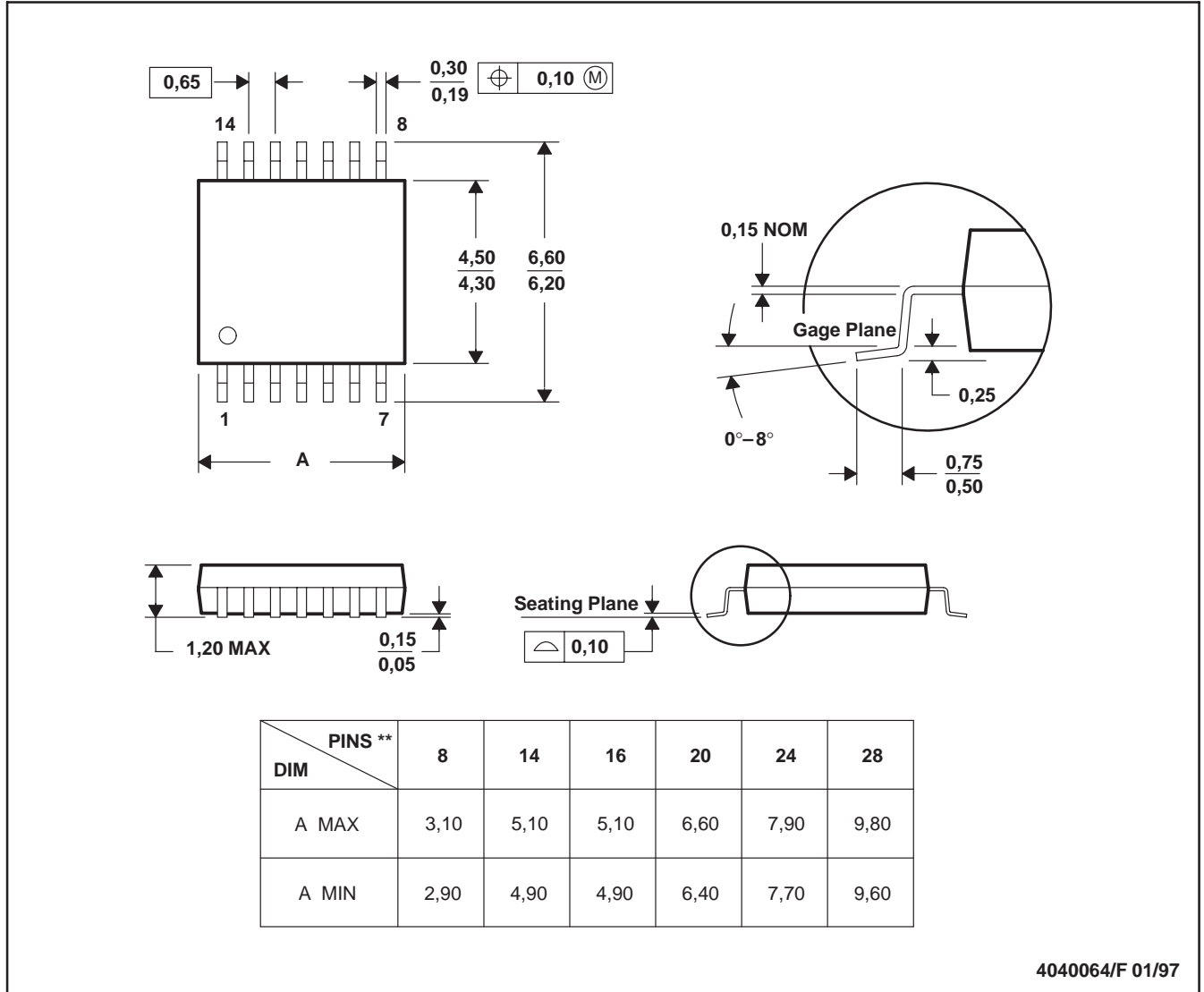

- NOTES:
- All linear dimensions are in millimeters.
 - This drawing is subject to change without notice.
 - Body dimensions do not include mold flash or protrusion not to exceed 0,15.
 - Falls within JEDEC MO-153

IMPORTANT NOTICE

Texas Instruments Incorporated and its subsidiaries (TI) reserve the right to make corrections, modifications, enhancements, improvements, and other changes to its products and services at any time and to discontinue any product or service without notice. Customers should obtain the latest relevant information before placing orders and should verify that such information is current and complete. All products are sold subject to TI's terms and conditions of sale supplied at the time of order acknowledgment.

TI warrants performance of its hardware products to the specifications applicable at the time of sale in accordance with TI's standard warranty. Testing and other quality control techniques are used to the extent TI deems necessary to support this warranty. Except where mandated by government requirements, testing of all parameters of each product is not necessarily performed.

TI assumes no liability for applications assistance or customer product design. Customers are responsible for their products and applications using TI components. To minimize the risks associated with customer products and applications, customers should provide adequate design and operating safeguards.

TI does not warrant or represent that any license, either express or implied, is granted under any TI patent right, copyright, mask work right, or other TI intellectual property right relating to any combination, machine, or process in which TI products or services are used. Information published by TI regarding third-party products or services does not constitute a license from TI to use such products or services or a warranty or endorsement thereof. Use of such information may require a license from a third party under the patents or other intellectual property of the third party, or a license from TI under the patents or other intellectual property of TI.

Reproduction of information in TI data books or data sheets is permissible only if reproduction is without alteration and is accompanied by all associated warranties, conditions, limitations, and notices. Reproduction of this information with alteration is an unfair and deceptive business practice. TI is not responsible or liable for such altered documentation.

Resale of TI products or services with statements different from or beyond the parameters stated by TI for that product or service voids all express and any implied warranties for the associated TI product or service and is an unfair and deceptive business practice. TI is not responsible or liable for any such statements.

Following are URLs where you can obtain information on other Texas Instruments products and application solutions:

Products		Applications	
Amplifiers	amplifier.ti.com	Audio	www.ti.com/audio
Data Converters	dataconverter.ti.com	Automotive	www.ti.com/automotive
DSP	dsp.ti.com	Broadband	www.ti.com/broadband
Interface	interface.ti.com	Digital Control	www.ti.com/digitalcontrol
Logic	logic.ti.com	Military	www.ti.com/military
Power Mgmt	power.ti.com	Optical Networking	www.ti.com/opticalnetwork
Microcontrollers	microcontroller.ti.com	Security	www.ti.com/security
		Telephony	www.ti.com/telephony
		Video & Imaging	www.ti.com/video
		Wireless	www.ti.com/wireless

Mailing Address: Texas Instruments
Post Office Box 655303 Dallas, Texas 75265