



TL071

Low noise JFET single operational amplifier

Features

- Wide common-mode (up to V_{CC}^+) and differential voltage range
- Low input bias and offset current
- Low noise $e_n = 15 \text{ nV}/\sqrt{\text{Hz}}$ (typ)
- Output short-circuit protection
- High input impedance JFET input stage
- Low harmonic distortion: 0.01% (typ)
- Internal frequency compensation
- Latch-up free operation
- High slew rate: $16 \text{ V}/\mu\text{s}$ (typ)

Description

The TL071, TL071A and TL071B are high-speed JFET input single operational amplifiers. Each of these JFET input operational amplifiers incorporates well matched, high-voltage JFET and bipolar transistors in a monolithic integrated circuit.

The devices feature high slew rates, low input bias and offset currents, and low offset voltage temperature coefficient.

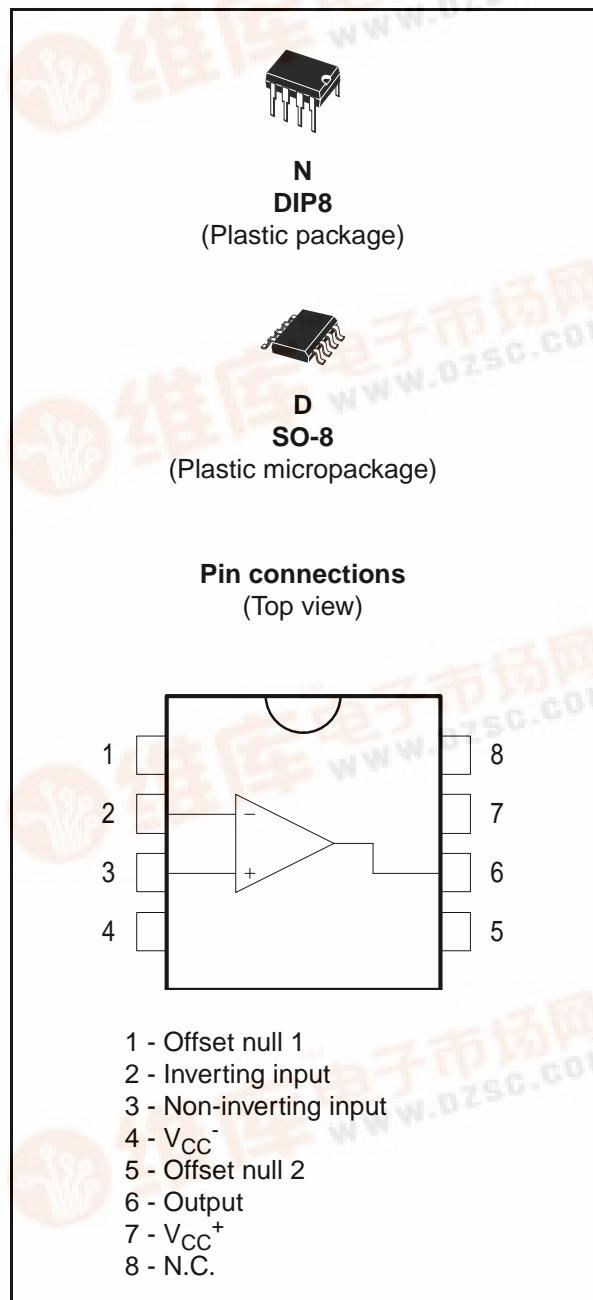

1 Schematic diagram

Figure 1. Circuit schematics

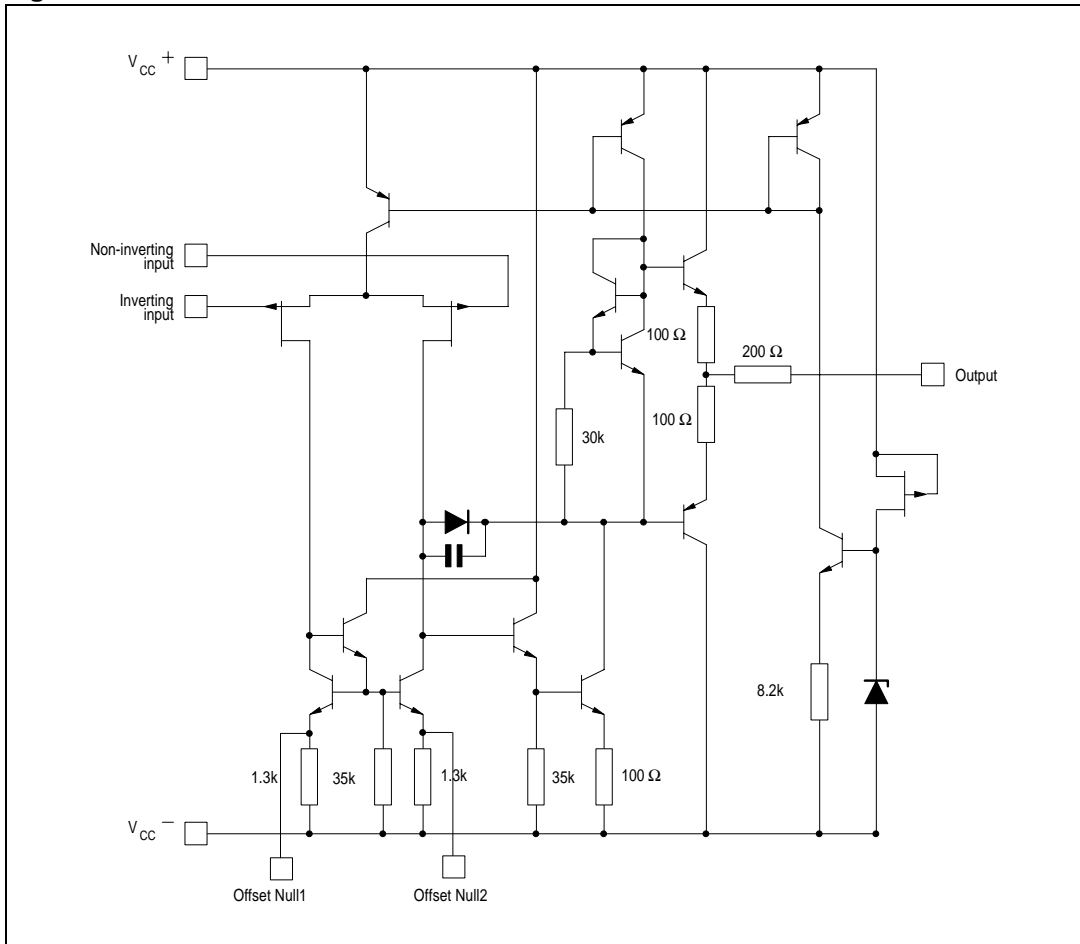
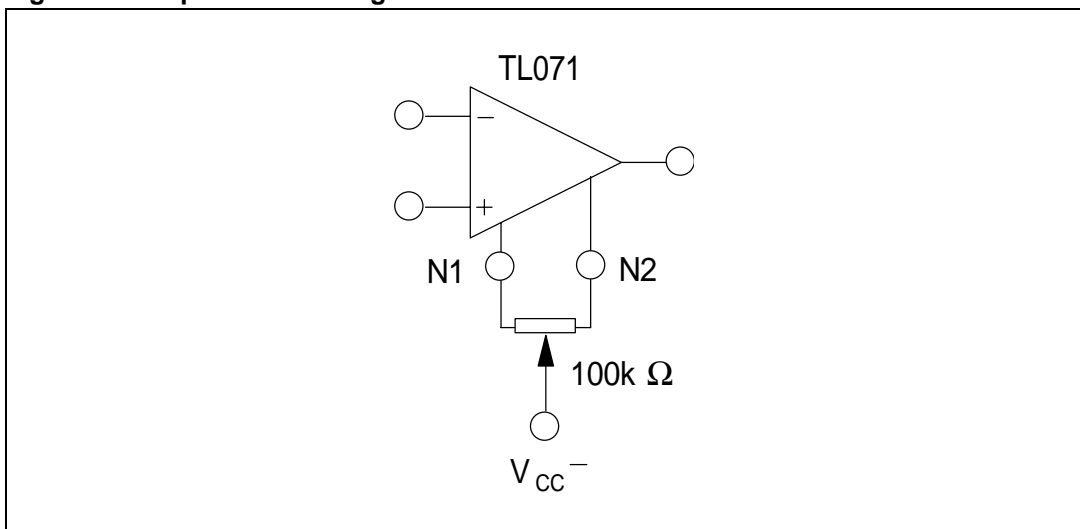

Figure 2. Input offset voltage null circuit



2 Absolute maximum ratings and operating conditions

Table 1. Absolute maximum ratings

Symbol	Parameter	Value			Unit
		TL071M, AM, BM	TL071I, AI, BI	TL071C, AC, BC	
V_{CC}	Supply voltage ⁽¹⁾	±18			V
V_i	Input voltage ⁽²⁾	±15			V
V_{id}	Differential input voltage ⁽³⁾	±30			V
P_{tot}	Power dissipation	680			mW
R_{thja}	Thermal resistance junction to ambient ^{(4) (5)}				°C/W
	SO-8	125			
	DIP8	85			
R_{thjc}	Thermal resistance junction to case ^{(4) (5)}				°C/W
	SO-8	40			
	DIP8	41			
	Output short-circuit duration ⁽⁶⁾	Infinite			
T_{oper}	Operating free-air temperature range	-55 to +125	-40 to +105	0 to +70	°C
T_{stg}	Storage temperature range	-65 to +150			°C
ESD	HBM: human body model ⁽⁷⁾	1			kV
	MM: machine model ⁽⁸⁾	200			V
	CDM: charged device model ⁽⁹⁾	1500			V

- All voltage values, except differential voltage, are with respect to the zero reference level (ground) of the supply voltages where the zero reference level is the midpoint between V_{CC}^+ and V_{CC}^- .
- The magnitude of the input voltage must never exceed the magnitude of the supply voltage or 15 volts, whichever is less.
- Differential voltages are the non-inverting input terminal with respect to the inverting input terminal.
- Short-circuits can cause excessive heating. Destructive dissipation can result from simultaneous short-circuits on all amplifiers.
- R_{th} are typical values.
- The output may be shorted to ground or to either supply. Temperature and/or supply voltages must be limited to ensure that the dissipation rating is not exceeded.
- Human body model: 100pF discharged through a 1.5kΩ resistor between two pins of the device, done for all couples of pin combinations with other pins floating.
- Machine model: a 200pF cap is charged to the specified voltage, then discharged directly between two pins of the device with no external series resistor (internal resistor < 5Ω), done for all couples of pin combinations with other pins floating.
- Charged device model: all pins plus package are charged together to the specified voltage and then discharged directly to the ground.

Table 2. Operating conditions

Symbol	Parameter	TL071M, AM, BM	TL071I, AI, BI	TL071C, AC, BC	Unit
V_{CC}	Supply voltage	6 to 36			V
T_{oper}	Operating free-air temperature range	-55 to +125	-40 to +105	0 to +70	°C

3 Electrical characteristics

Table 3. $V_{CC} = \pm 15V$, $T_{amb} = +25^\circ C$ (unless otherwise specified)

Symbol	Parameter	TL071I,M,AC,AI,AM, BC,BI,BM			TL071C			Unit
		Min.	Typ.	Max.	Min.	Typ.	Max.	
V_{io}	Input offset voltage ($R_S = 50\Omega$)							mV
	$T_{amb} = +25^\circ C$		3	10		3	10	
	TL071		3	6				
	TL071A		1	3				
$T_{min} \leq T_{amb} \leq T_{max}$	TL071B			13			13	
	TL071			7				
	TL071A			5				
DL_{io}	Input offset voltage drift		10			10		$\mu V/^\circ C$
I_{io}	Input offset current							pA nA
	$T_{amb} = +25^\circ C$		5	100		5	100	
$T_{min} \leq T_{amb} \leq T_{max}$				4			10	
I_{ib}	Input bias current ⁽¹⁾							pA nA
	$T_{amb} = +25^\circ C$		20	200		20	200	
$T_{min} \leq T_{amb} \leq T_{max}$				20			20	
A_{vd}	Large signal voltage gain ($R_L = 2k\Omega$, $V_o = \pm 10V$)							V/mV
	$T_{amb} = +25^\circ C$	50	200		25	200		
$T_{min} \leq T_{amb} \leq T_{max}$		25			15			
SVR	Supply voltage rejection ratio ($R_S = 50\Omega$)							dB
	$T_{amb} = +25^\circ C$	80	86		70	86		
$T_{min} \leq T_{amb} \leq T_{max}$		80			70			
I_{CC}	Supply current, no load							mA
	$T_{amb} = +25^\circ C$		1.4	2.5		1.4	2.5	
$T_{min} \leq T_{amb} \leq T_{max}$				2.5			2.5	
V_{icm}	Input common mode voltage range	± 11	+15 -12		± 11	+15 -12		V
CMR	Common mode rejection ratio ($R_S = 50\Omega$)							dB
	$T_{amb} = +25^\circ C$	80	86		70	86		
$T_{min} \leq T_{amb} \leq T_{max}$		80			70			
I_{os}	Output short-circuit current							mA
	$T_{amb} = +25^\circ C$	10	40	60	10	40	60	
$T_{min} \leq T_{amb} \leq T_{max}$		10		60	10		60	
$\pm V_{Opp}$	Output voltage swing							V
	$T_{amb} = +25^\circ C$	10	12		10	12		
	$R_L = 2k\Omega$							
	$R_L = 10k\Omega$	12	13.5		12	13.5		
$T_{min} \leq T_{amb} \leq T_{max}$	$R_L = 2k\Omega$	10			10			
	$R_L = 10k\Omega$	12			12			
SR	Slew rate ($T_{amb} = +25^\circ C$) $V_{in} = 10V$, $R_L = 2k\Omega$, $C_L = 100pF$, unity gain	8	16		8	16		V/ μs

Table 3. $V_{CC} = \pm 15V$, $T_{amb} = +25^{\circ}C$ (unless otherwise specified) (continued)

Symbol	Parameter	TL0711,M,AC,AI,AM, BC,BI,BM			TL071C			Unit
		Min.	Typ.	Max.	Min.	Typ.	Max.	
t_r	Rise time ($T_{amb} = +25^{\circ}C$) $V_{in} = 20mV$, $R_L = 2k\Omega$, $C_L = 100pF$, unity gain		0.1			0.1		μs
K_{ov}	Overshoot ($T_{amb} = +25^{\circ}C$) $V_{in} = 20mV$, $R_L = 2k\Omega$, $C_L = 100pF$, unity gain		10			10		%
GBP	Gain bandwidth product ($T_{amb} = +25^{\circ}C$) $V_{in} = 10mV$, $R_L = 2k\Omega$, $C_L = 100pF$, $f = 100kHz$	2.5	4		2.5	4		MHz
R_i	Input resistance		10^{12}			10^{12}		Ω
THD	Total harmonic distortion ($T_{amb} = +25^{\circ}C$, $f = 1kHz$, $R_L = 2k\Omega$, $C_L = 100pF$, $A_v = 20dB$, $V_o = 2V_{pp}$)		0.01			0.01		%
e_n	Equivalent input noise voltage $R_S = 100\Omega$, $f = 1KHz$		15			15		$\frac{nV}{\sqrt{Hz}}$
ϕ_m	Phase margin		45			45		degrees

- The input bias currents are junction leakage currents which approximately double for every $10^{\circ}C$ increase in the junction temperature.

Figure 3. Maximum peak-to-peak output voltage versus frequency

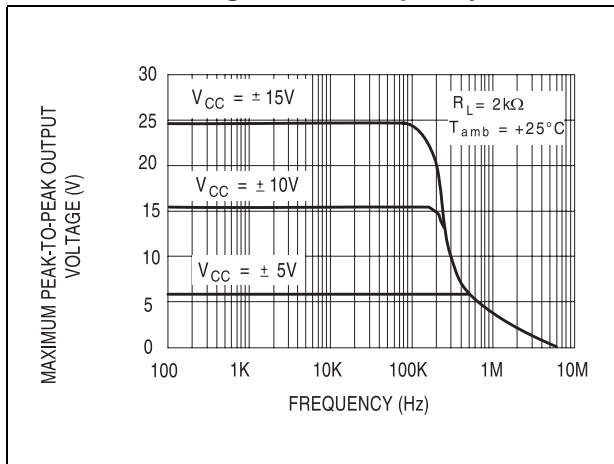

Figure 4. Maximum peak-to-peak output voltage versus frequency

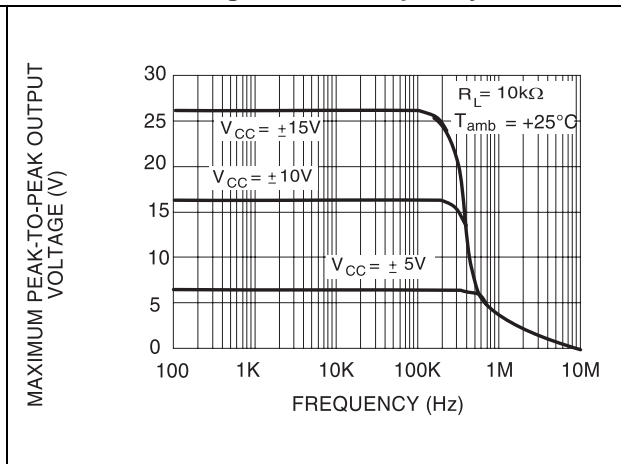

Figure 5. Maximum peak-to-peak output voltage versus frequency

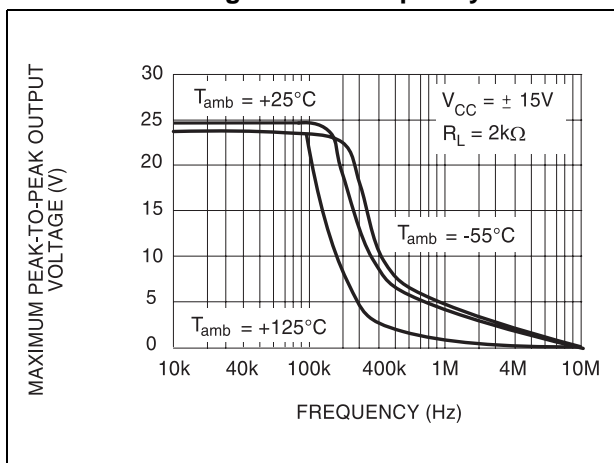

Figure 6. Maximum peak-to-peak output voltage versus free air temp.

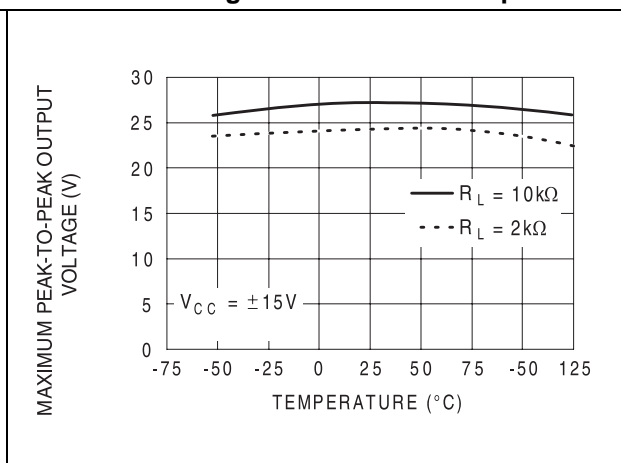

Figure 7. Maximum peak-to-peak output voltage versus load resistance

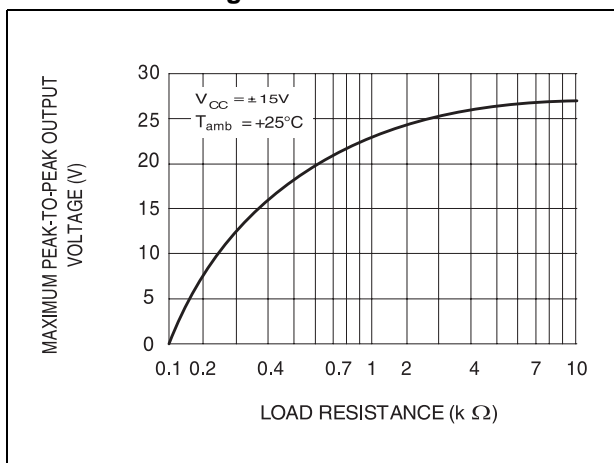

Figure 8. Maximum peak-to-peak output voltage versus supply voltage

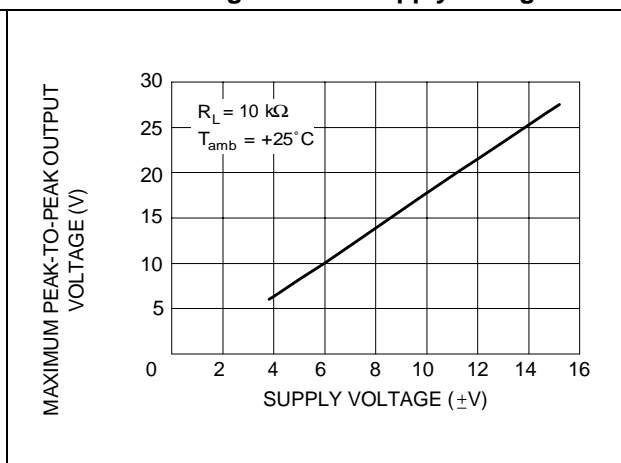

Figure 9. Input bias current versus free air temperature

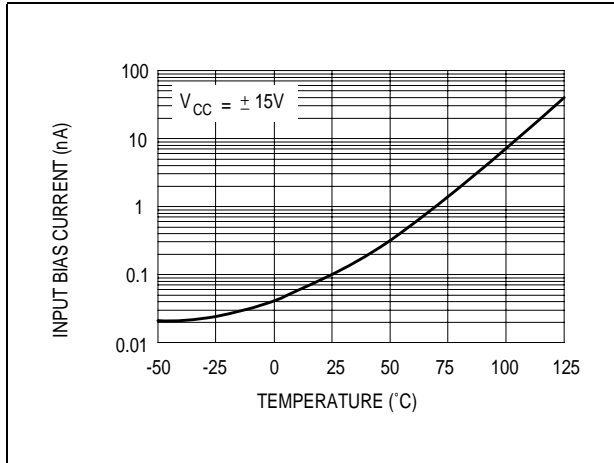

Figure 10. Large signal differential voltage amplification versus free air temp.

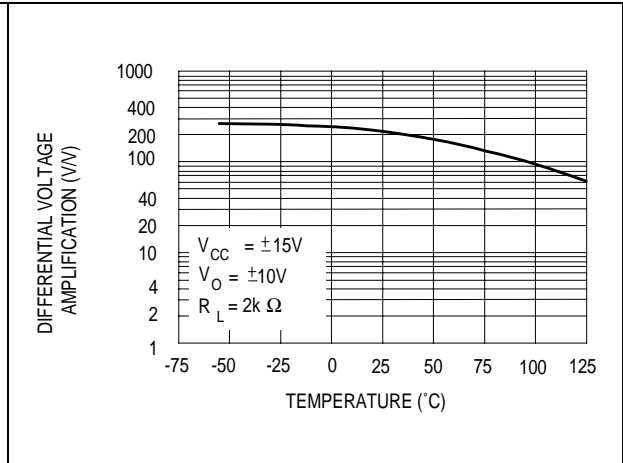

Figure 11. Large signal differential voltage amplification and phase shift versus frequency

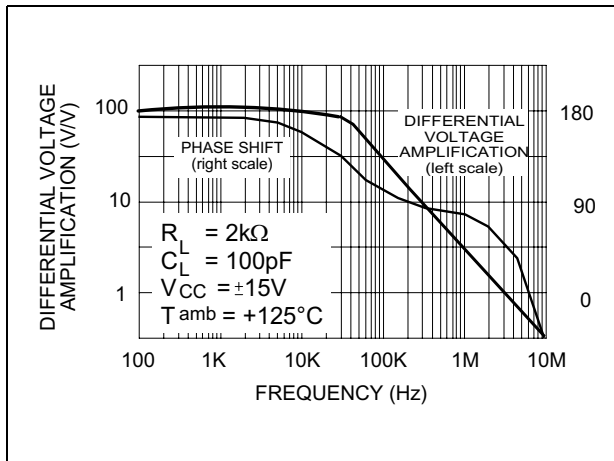

Figure 12. Total power dissipation versus free air temperature

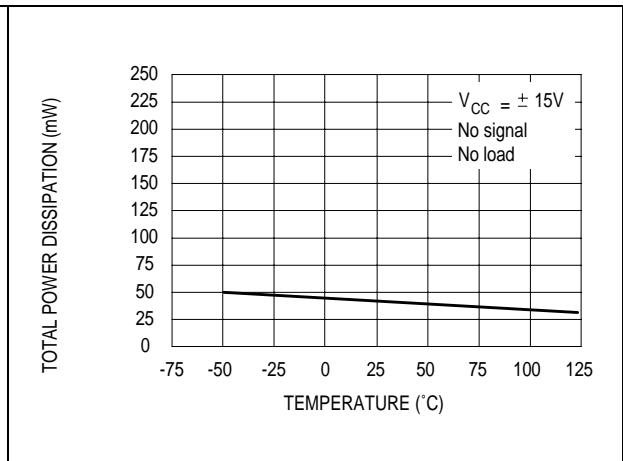

Figure 13. Supply current per amplifier versus free air temperature

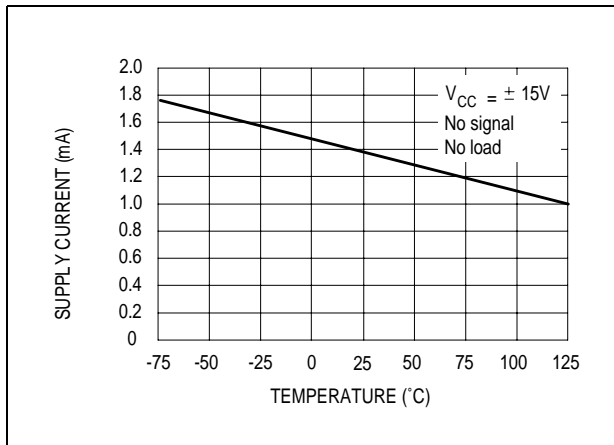

Figure 14. Common mode rejection ratio versus free air temperature

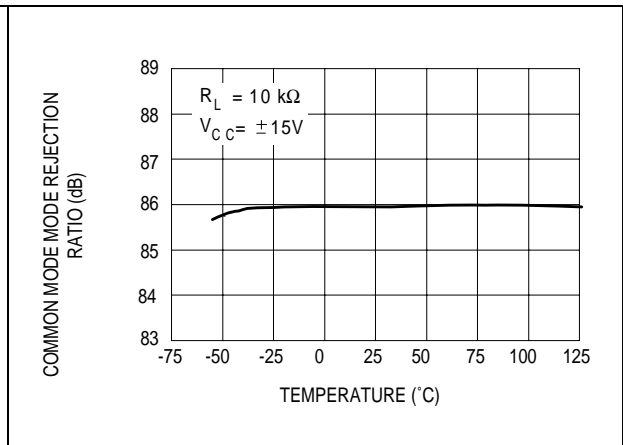

Figure 15. Voltage follower large signal pulse response

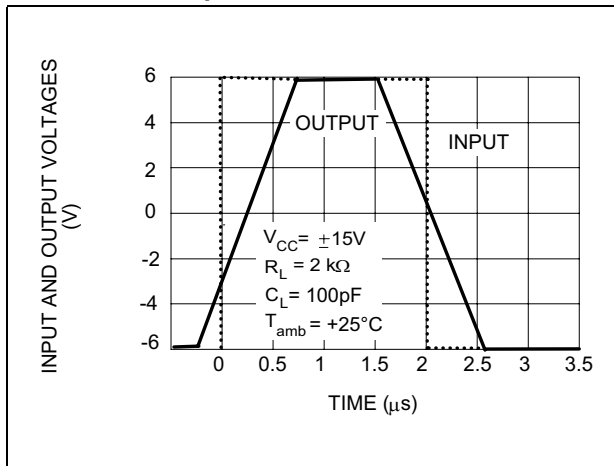

Figure 16. Output voltage versus elapsed time

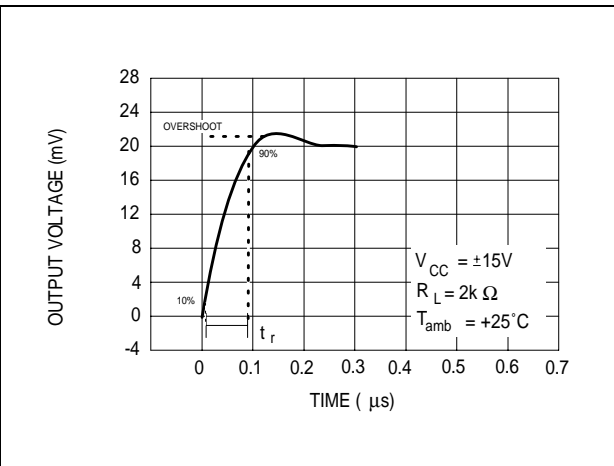

Figure 17. Equivalent input noise voltage versus frequency

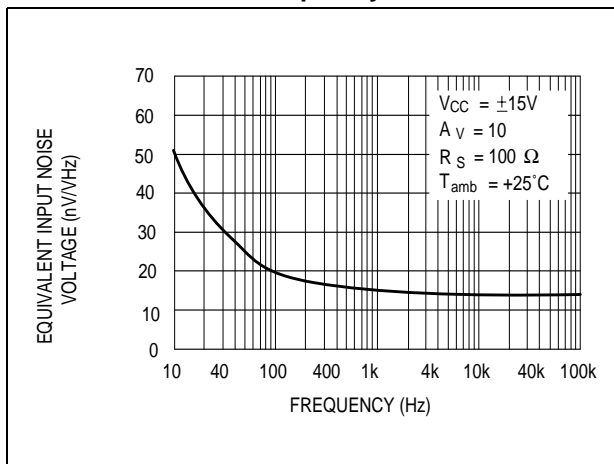
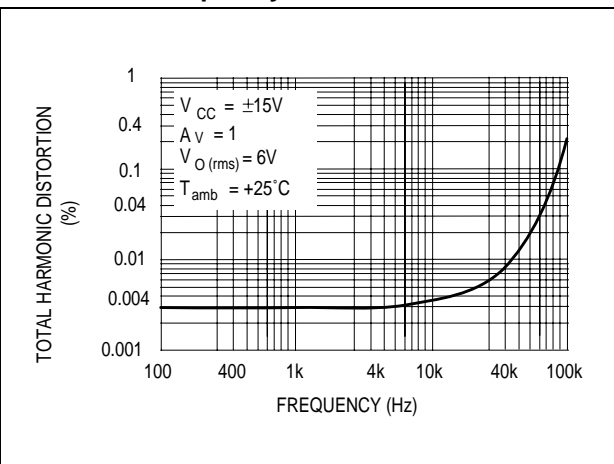

Figure 18. Total harmonic distortion versus frequency



Parameter measurement information

Figure 19. Voltage follower

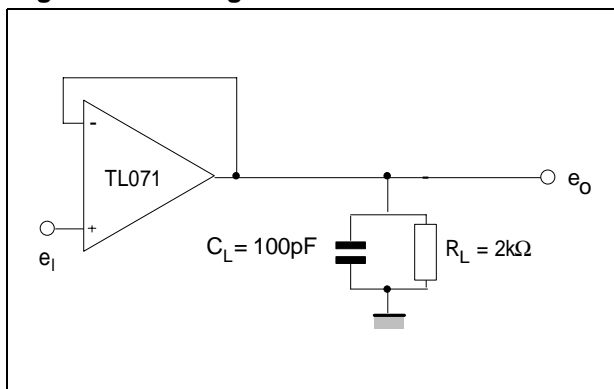
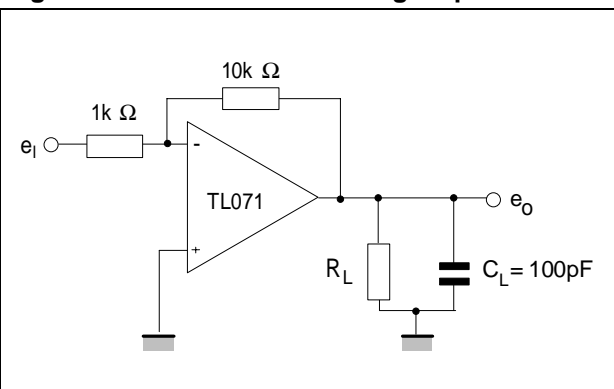

Figure 20. Gain-of-10 inverting amplifier



4 Typical applications

Figure 21. (0.5Hz) Square wave oscillator

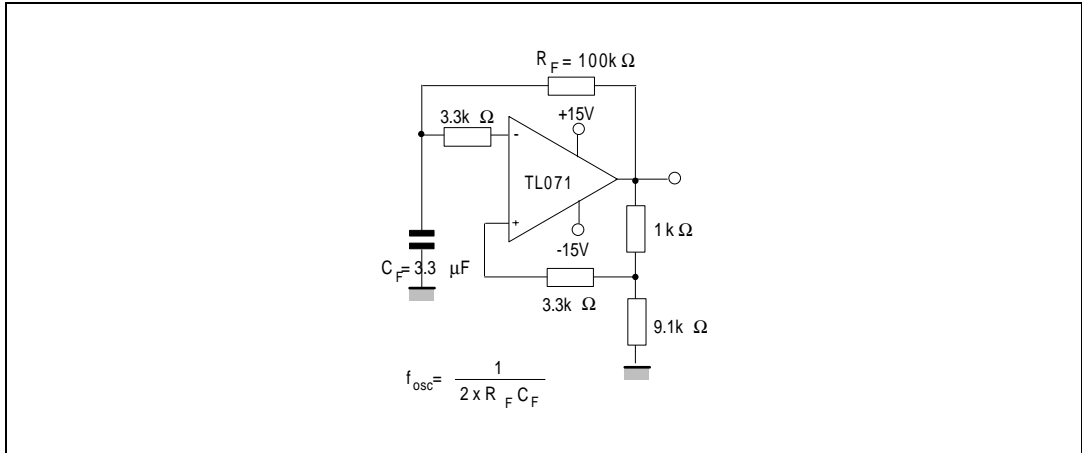
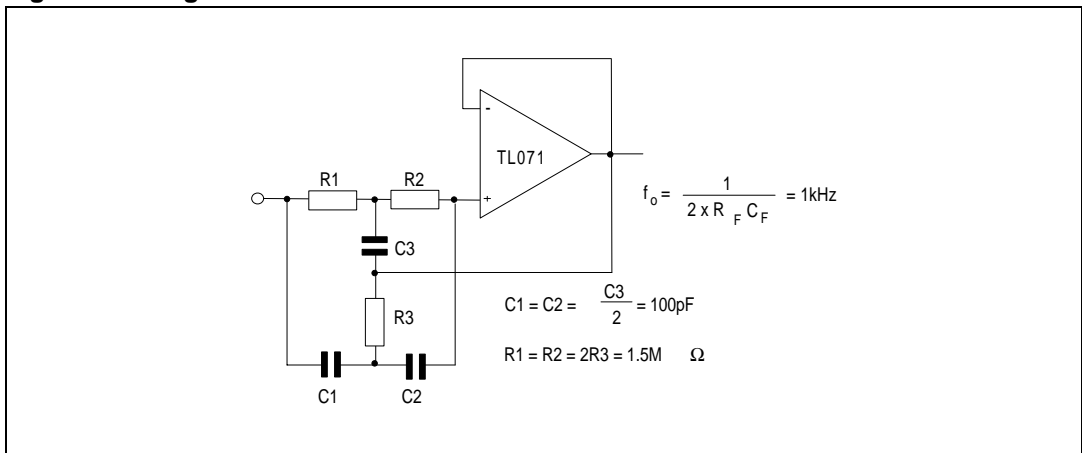

Figure 22. High Q notch filter



5 Package information

In order to meet environmental requirements, ST offers these devices in ECOPACK® packages. These packages have a lead-free second level interconnect. The category of second level interconnect is marked on the package and on the inner box label, in compliance with JEDEC Standard JESD97. The maximum ratings related to soldering conditions are also marked on the inner box label. ECOPACK is an ST trademark. ECOPACK specifications are available at: www.st.com.

Figure 23. DIP8 package mechanical data

Ref.	Dimensions					
	Millimeters			Inches		
	Min.	Typ.	Max.	Min.	Typ.	Max.
A			5.33			0.210
A1	0.38			0.015		
A2	2.92	3.30	4.95	0.115	0.130	0.195
b	0.36	0.46	0.56	0.014	0.018	0.022
b2	1.14	1.52	1.78	0.045	0.060	0.070
c	0.20	0.25	0.36	0.008	0.010	0.014
D	9.02	9.27	10.16	0.355	0.365	0.400
E	7.62	7.87	8.26	0.300	0.310	0.325
E1	6.10	6.35	7.11	0.240	0.250	0.280
e		2.54			0.100	
eA		7.62			0.300	
eB			10.92			0.430
L	2.92	3.30	3.81	0.115	0.130	0.150

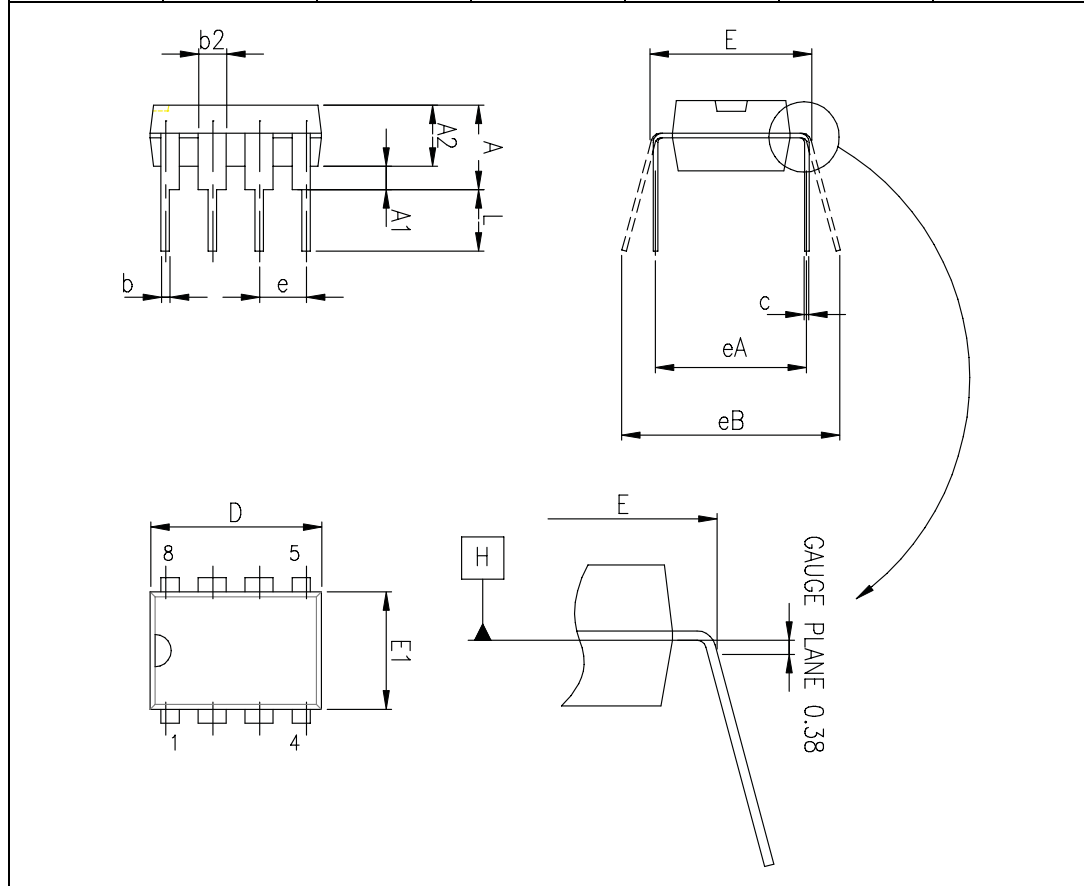
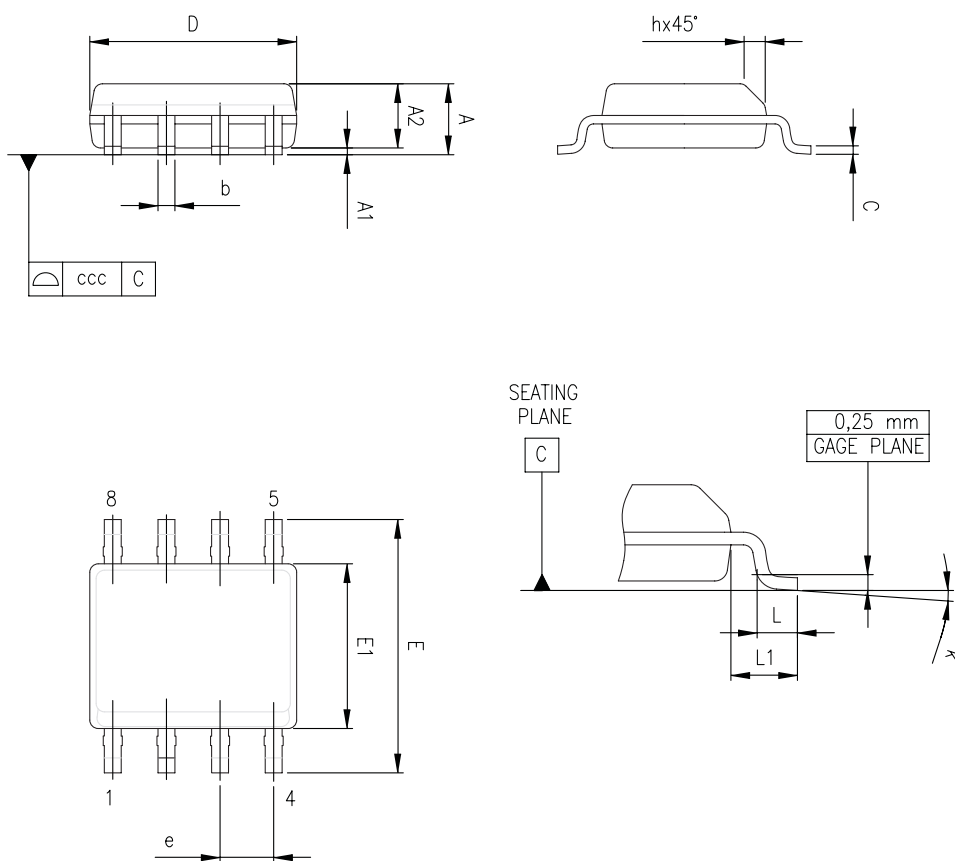

Figure 24. SO-8 package mechanical data

Ref.	Dimensions					
	Millimeters			Inches		
	Min.	Typ.	Max.	Min.	Typ.	Max.
A			1.75			0.069
A1	0.10		0.25	0.004		0.010
A2	1.25			0.049		
b	0.28		0.48	0.011		0.019
c	0.17		0.23	0.007		0.010
D	4.80	4.90	5.00	0.189	0.193	0.197
H	5.80	6.00	6.20	0.228	0.236	0.244
E1	3.80	3.90	4.00	0.150	0.154	0.157
e		1.27			0.050	
h	0.25		0.50	0.010		0.020
L	0.40		1.27	0.016		0.050
k	1°		8°	1°		8°
ccc			0.10			0.004



6 Ordering information

Table 4. Order codes

Part number	Temperature range	Package	Packing	Marking
TL071MN TL071AMN TL071BMN	-55°C, +125°C	DIP8	Tube	TL071MN TL071AMN TL071BMN
TL071MD/MDT TL071AMD/AMDT TL071BMD/BMDT		SO-8	Tube or tape & reel	071M 071AM 071BM
TL071IN TL071AIN TL071BIN	-40°C, +105°C	DIP8	Tube	TL071IN TL071AIN TL071BIN
TL071ID/IDT TL071AID/AIDT TL071BID/BIDT		SO-8	Tube or tape & reel	071I 071AI 071BI
TL071CN TL071ACN TL071BCN	0°C, +70°C	DIP8	Tube	TL071CN TL071ACN TL071BCN
TL071CD/CDT TL071ACD/ACDT TL071BCD/BCDT		SO-8	Tube or tape & reel	071C 071AC 071BC

7 Revision history

Table 5. Document revision history

Date	Revision	Changes
29-Mar-2001	1	Initial release.
30-Jul-2007	2	Added values for R_{thja} , R_{thjc} and ESD in Table 1: Absolute maximum ratings . Added Table 2: Operating conditions . Expanded Table 4: Order codes . Format update.

Please Read Carefully:

Information in this document is provided solely in connection with ST products. STMicroelectronics NV and its subsidiaries ("ST") reserve the right to make changes, corrections, modifications or improvements, to this document, and the products and services described herein at any time, without notice.

All ST products are sold pursuant to ST's terms and conditions of sale.

Purchasers are solely responsible for the choice, selection and use of the ST products and services described herein, and ST assumes no liability whatsoever relating to the choice, selection or use of the ST products and services described herein.

No license, express or implied, by estoppel or otherwise, to any intellectual property rights is granted under this document. If any part of this document refers to any third party products or services it shall not be deemed a license grant by ST for the use of such third party products or services, or any intellectual property contained therein or considered as a warranty covering the use in any manner whatsoever of such third party products or services or any intellectual property contained therein.

UNLESS OTHERWISE SET FORTH IN ST'S TERMS AND CONDITIONS OF SALE ST DISCLAIMS ANY EXPRESS OR IMPLIED WARRANTY WITH RESPECT TO THE USE AND/OR SALE OF ST PRODUCTS INCLUDING WITHOUT LIMITATION IMPLIED WARRANTIES OF MERCHANTABILITY, FITNESS FOR A PARTICULAR PURPOSE (AND THEIR EQUIVALENTS UNDER THE LAWS OF ANY JURISDICTION), OR INFRINGEMENT OF ANY PATENT, COPYRIGHT OR OTHER INTELLECTUAL PROPERTY RIGHT.

UNLESS EXPRESSLY APPROVED IN WRITING BY AN AUTHORIZED ST REPRESENTATIVE, ST PRODUCTS ARE NOT RECOMMENDED, AUTHORIZED OR WARRANTED FOR USE IN MILITARY, AIR CRAFT, SPACE, LIFE SAVING, OR LIFE SUSTAINING APPLICATIONS, NOR IN PRODUCTS OR SYSTEMS WHERE FAILURE OR MALFUNCTION MAY RESULT IN PERSONAL INJURY, DEATH, OR SEVERE PROPERTY OR ENVIRONMENTAL DAMAGE. ST PRODUCTS WHICH ARE NOT SPECIFIED AS "AUTOMOTIVE GRADE" MAY ONLY BE USED IN AUTOMOTIVE APPLICATIONS AT USER'S OWN RISK.

Resale of ST products with provisions different from the statements and/or technical features set forth in this document shall immediately void any warranty granted by ST for the ST product or service described herein and shall not create or extend in any manner whatsoever, any liability of ST.

ST and the ST logo are trademarks or registered trademarks of ST in various countries.

Information in this document supersedes and replaces all information previously supplied.

The ST logo is a registered trademark of STMicroelectronics. All other names are the property of their respective owners.

© 2007 STMicroelectronics - All rights reserved

STMicroelectronics group of companies

Australia - Belgium - Brazil - Canada - China - Czech Republic - Finland - France - Germany - Hong Kong - India - Israel - Italy - Japan - Malaysia - Malta - Morocco - Singapore - Spain - Sweden - Switzerland - United Kingdom - United States of America

www.st.com