

TL080, TL081, TL082, TL084, TL081A, TL082A, TL084A
TL081B, TL082B, TL084B, TL082Y, TL084Y
JFET-INPUT OPERATIONAL AMPLIFIERS

SLOS081A-D2297, FEBRUARY 1977-REVISED NOVEMBER 1992

24 DEVICES COVER COMMERCIAL, INDUSTRIAL, AND MILITARY TEMPERATURE RANGES

- Low-Power Consumption
- Wide Common-Mode and Differential Voltage Ranges
- Low Input Bias and Offset Currents
- Output Short-Circuit Protection
- Low Total Harmonic Distortion . . . 0.003% Typ
- High Input Impedance . . . JFET-Input Stage
- Internal Frequency Compensation (Except TL080, TL080A)
- Latch-Up-Free Operation
- High Slew Rate . . . 13 V/ μ s Typ
- Common-Mode Input Voltage Range Includes V_{CC+}

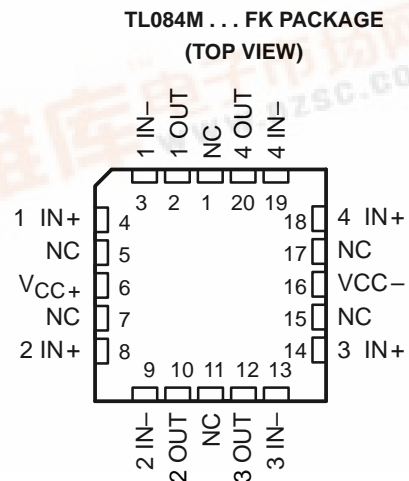
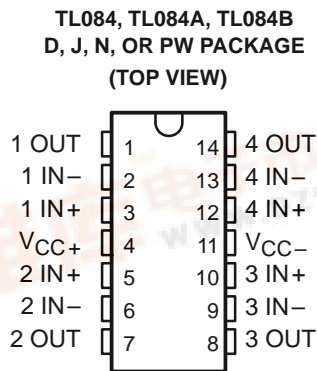
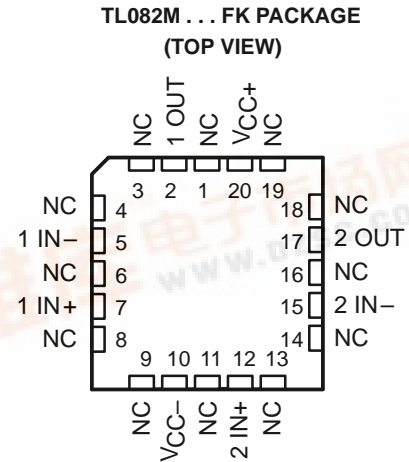
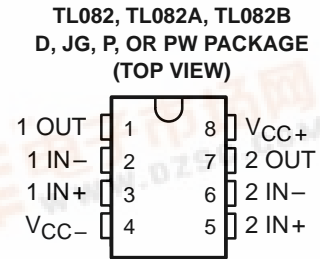
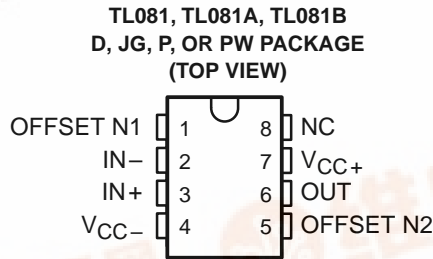
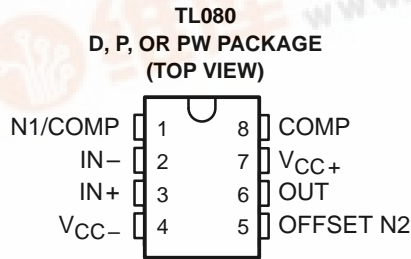

NC—No internal connection



PRODUCTION DATA information is current as of publication date. Products conform to specifications per the terms of Texas Instruments standard warranty. Production processing does not necessarily include testing of all parameters.



Copyright © 1992, Texas Instruments Incorporated
On products compliant to MIL-STD-883, Class B, all parameters are tested unless otherwise noted. On all other products, production processing does not necessarily include testing of all parameters.

TL080, TL081, TL082, TL084, TL081A, TL082A, TL084A TL081B, TL082B, TL084B, TL082Y, TL084Y JFET-INPUT OPERATIONAL AMPLIFIERS

SLOS081A–D2297, FEBRUARY 1977–REVISED NOVEMBER 1992

symbols

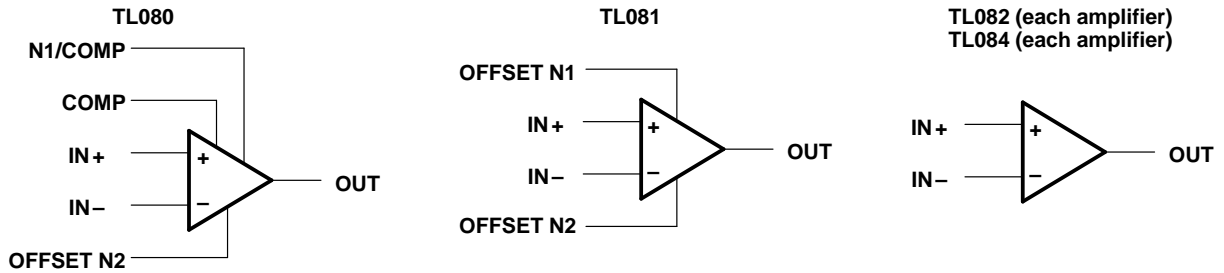

description

The TL08_ JFET-input operational amplifier family is designed to offer a wider selection than any previously developed operational amplifier family. Each of these JFET-input operational amplifiers incorporates well-matched, high-voltage JFET and bipolar transistors in a monolithic integrated circuit. The devices feature high slew rates, low input bias and offset currents, and low offset voltage temperature coefficient. Offset adjustment and external compensation options are available within the TL08_ family.

Device types with a C suffix are characterized for operation from 0°C to 70°C, those with an I suffix are characterized for operation from –40°C to 85°C, and those with an M suffix are characterized for operation over the full military temperature range of –55°C to 125°C.

AVAILABLE OPTIONS

T _A	V _{IO} MAX at 25°C	PACKAGE								CHIP FORM (Y)
		SMALL OUTLINE (D008)	SMALL OUTLINE (D014)	CHIP CARRIER (FK)	CERAMIC DIP (J)	CERAMIC DIP (JG)	PLASTIC DIP (N)	PLASTIC DIP (P)	TSSOP (PW)	
0°C to 70°C	15 mV	TL080CD						TL080CP	TL080CPW	
	15 mV	TL081CD	—	—	—	—	—	TL081CP	TL081CPW	—
	6 mV	TL081ACD						TL081ACP		
	3 mV	TL081BCD						TL081BCP		
	15 mV	TL082CD						TL082CP	TL082CPW	TL082Y
	6 mV	TL082ACD						TL082ACP		
	3 mV	TL082BCD					TL082BCP			
	15 mV		TL084CD				TL084CN		TL084CPW	TL084Y
	6 mV	—	TL084ACD	—	—	—	TL084ACN	—		
	3 mV		TL084BCD				TL084BCN			
–40°C to 85°C	6 mV	TL081ID						TL081IP		
	6 mV	TL082ID						TL082IP	—	—
	6 mV	TL084ID	TL084ID				TL084IN			
–55°C to 125°C	6 mV			TL081MFK		TL081MJG				
	6 mV	—	—	TL082MFK		TL082MJG	—	—	—	—
	9 mV			TL084MFK	TL084MJ					

The D package is available taped and reeled. Add R suffix to device type, (e.g., TL080CDR).

TL080, TL081, TL082, TL084, TL081A, TL082A, TL084A
 TL081B, TL082B, TL084B
JFET-INPUT OPERATIONAL AMPLIFIERS

SLOS081A-D2297, FEBRUARY 1977-REVISED NOVEMBER 1992

schematic (each amplifier)

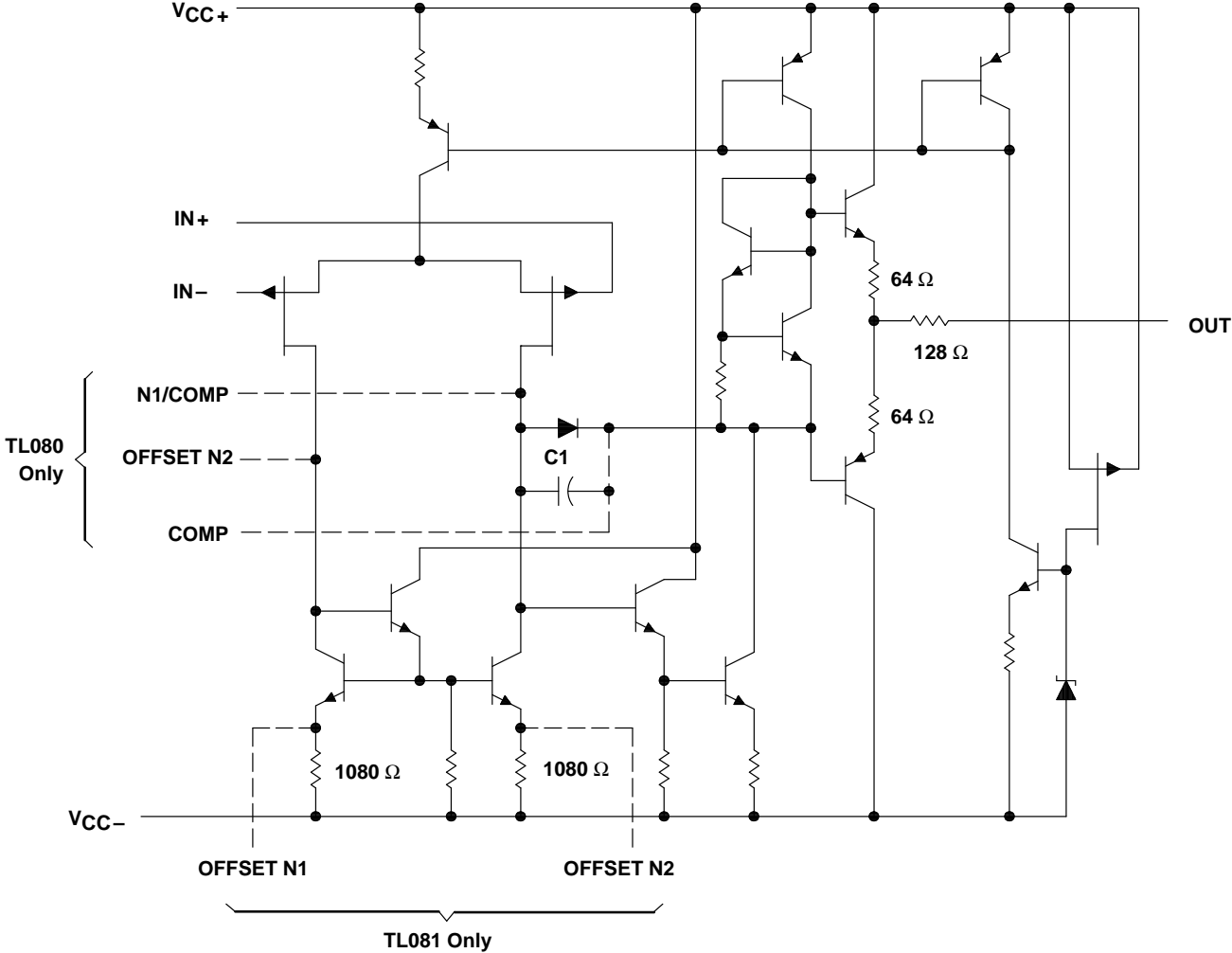

C1 = 18 pF on TL081, TL082, and TL084 only (including their suffix versions).
 Component values shown are nominal.

TL082Y

JFET-INPUT DUAL OPERATIONAL AMPLIFIER

SLOS081A–D2297, FEBRUARY 1977–REVISED NOVEMBER 1992

chip information

These chips, when properly assembled, display characteristics similar to the TL082. Thermal compression or ultrasonic bonding may be used on the doped aluminum bonding pads. Chips may be mounted with conductive epoxy or a gold-silicon preform.

BONDING PAD ASSIGNMENTS

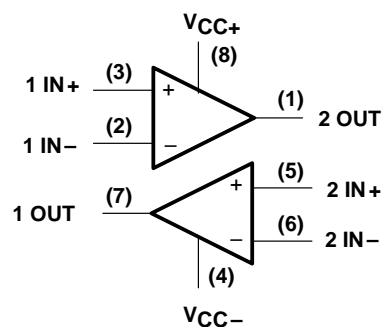

CHIP THICKNESS: 15 TYPICAL

BONDING PADS: 4 × 4 MINIMUM

T_{jmax} = 150°C

TOLERANCES ARE ±10%

ALL DIMENSIONS ARE IN MILS

PIN (4) INTERNALLY CONNECTED
TO BACKSIDE OF CHIP

TL084Y JFET-INPUT QUAD OPERATIONAL AMPLIFIER

SLOS081A-D2297, FEBRUARY 1977-REVISED NOVEMBER 1992

chip information

These chips, when properly assembled, display characteristics similar to the TL084. Thermal compression or ultrasonic bonding may be used on the doped aluminum bonding pads. Chips may be mounted with conductive epoxy or a gold-silicon preform.

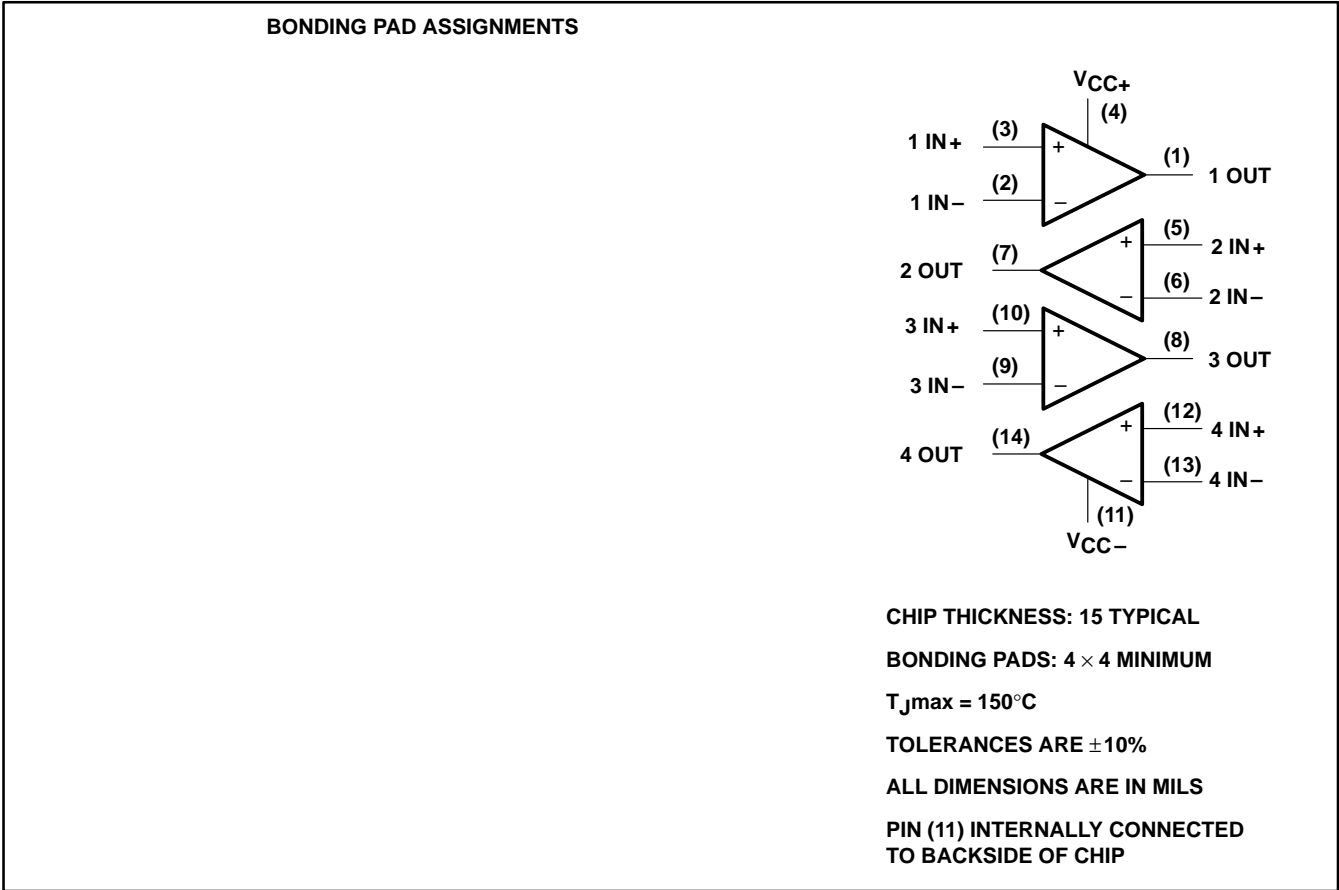

**TL080, TL081, TL082, TL084, TL081A, TL082A, TL084A
TL081B, TL082B, TL084B
JFET-INPUT OPERATIONAL AMPLIFIERS**

SLOS081A–D2297, FEBRUARY 1977–REVISED NOVEMBER 1992

absolute maximum ratings over operating free-air temperature range (unless otherwise noted)

	TL08_C TL08_AC TL08_BC	TL08_I	TL08_M	UNIT
Supply voltage, V_{CC+} (see Note 1)	18	18	18	V
Supply voltage V_{CC-} (see Note 1)	–18	–18	–18	V
Differential input voltage (see Note 2)	± 30	± 30	± 30	V
Input voltage (see Notes 1 and 3)	± 15	± 15	± 15	V
Duration of output short circuit (see Note 4)	unlimited	unlimited	unlimited	
Continuous total dissipation	See Dissipation Rating Table			
Operating free-air temperature range	0 to 70	– 40 to 85	– 55 to 125	°C
Storage temperature range	– 65 to 150	– 65 to 150	– 65 to 150	°C
Case temperature for 60 seconds	FK package		260	°C
Lead temperature 1,6 mm (1/16 inch) from case for 60 seconds	J or JG package		300	°C
Lead temperature 1,6 mm (1/16 inch) from case for 10 seconds	D, N, P, or PW package	260	260	°C

- NOTES: 1. All voltage values, except differential voltages, are with respect to the midpoint between V_{CC+} and V_{CC-} .
 2. Differential voltages are at the noninverting input terminal with respect to the inverting input terminal.
 3. The magnitude of the input voltage must never exceed the magnitude of the supply voltage or 15 V, whichever is less.
 4. The output may be shorted to ground or to either supply. Temperature and/or supply voltages must be limited to ensure that the dissipation rating is not exceeded.

DISSIPATION RATING TABLE

PACKAGE	$T_A \leq 25^\circ\text{C}$ POWER RATING	DERATING FACTOR	DERATE ABOVE T_A	$T_A = 70^\circ\text{C}$ POWER RATING	$T_A = 85^\circ\text{C}$ POWER RATING	$T_A = 125^\circ\text{C}$ POWER RATING
D (8 Pin)	680 mW	5.8 mW/°C	32°C	464 mW	377 mW	N/A
D (14 Pin)	680 mW	7.6 mW/°C	60°C	608 mW	494 mW	N/A
FK	680 mW	11.0 mW/°C	88°C	680 mW	680 mW	275 mW
J	680 mW	11.0 mW/°C	88°C	680 mW	680 mW	275 mW
JG	680 mW	8.4 mW/°C	69°C	672 mW	546 mW	210 mW
N	680 mW	9.2 mW/°C	76°C	680 mW	598 mW	N/A
P	680 mW	8.0 mW/°C	65°C	640 mW	520 mW	N/A
PW (8 Pin)	525 mW	4.2 mW/°C	25°C	336 mW	N/A	N/A
PW (14 Pin)	700 mW	5.6 mW/°C	25°C	448 mW	N/A	N/A

TL080, TL081, TL084, TL081A, TL082A, TL084A
 TL081B, TL082B, TL084B
JFET-INPUT OPERATIONAL AMPLIFIERS

SLOS081A–D2297, FEBRUARY 1977–REVISED NOVEMBER 1992

electrical characteristics, $V_{CC\pm} = \pm 15\text{ V}$ (unless otherwise noted)

PARAMETER	TEST CONDITIONST	TL080C			TL081AC			TL081BC			TL081I			UNIT
		MIN	TYP	MAX	MIN	TYP	MAX	MIN	TYP	MAX	MIN	TYP	MAX	
V_{IO}	Input offset voltage	$V_O = 0$, $R_S = 50\ \Omega$		3	15	3	6	2	3	3	6	6	mV	
αV_{IO}	Temperature coefficient of input offset voltage	$V_O = 0$, $T_A = \text{full range}$		18		18		18		18		18	$\mu\text{V}/^\circ\text{C}$	
I_{IO}	Input offset current †	$V_O = 0$		5	200	5	100	5	100	5	100	100	pA	
I_{IB}	Input bias current †	$V_O = 0$		30	400	30	200	30	200	30	200	200	nA	
V_{ICR}	Common-mode input voltage range	$T_A = 25^\circ\text{C}$		± 11	to 15	± 11	to 15	± 11	to 15	± 11	to 15	-12 to 15	V	
V_{OM}	Maximum peak output voltage swing	$T_A = 25^\circ\text{C}$		± 12	± 13.5	± 12	± 13.5	± 12	± 13.5	± 12	± 13.5	± 12	± 13.5	V
		$T_A = \text{full range}$		± 12		± 12		± 12		± 12		± 12		
		$T_A = 25^\circ\text{C}$		± 10	± 12	± 10	± 12	± 10	± 12	± 10	± 12	± 10	± 12	
A_{VD}	Large-signal differential voltage amplification	$V_O = \pm 10\text{ V}$, $T_A = 25^\circ\text{C}$		25	200	25	200	25	200	25	200	200	V/mV	
B_1	Unity-gain bandwidth	$T_A = 25^\circ\text{C}$		15		15		25		25		25	MHz	
f_i	Input resistance	$T_A = 25^\circ\text{C}$		3		3		3		3		3	Ω	
$CMRR$	Common-mode rejection ratio	$V_{IC} = V_{ICR\text{ min}}$, $R_S = 50\ \Omega$, $T_A = 25^\circ\text{C}$		70	86	80	86	80	86	80	86	80	86	dB
k_{SVR}	Supply voltage rejection ratio ($\Delta V_{CC\pm} / \Delta V_{IO}$)	$V_{CC} = \pm 15\text{ V}$ to $\pm 9\text{ V}$, $R_S = 50\ \Omega$, $T_A = 25^\circ\text{C}$		70	86	80	86	80	86	80	86	80	86	dB
I_{CC}	Supply current (per amplifier)	No load, $T_A = 25^\circ\text{C}$		1.4	2.8	1.4	2.8	1.4	2.8	1.4	2.8	1.4	2.8	mA
V_{O1}/V_{O2}	Crosstalk attenuation	$A_{VD} = 100$, $T_A = 25^\circ\text{C}$		120		120		120		120		120	dB	

† All characteristics are measured under open-loop conditions with zero common-mode voltage unless otherwise specified. Full range for T_A is 0°C to 70°C for TL08_C, TL08_AC, TL08_BC and -40°C to 85°C for TL08_I.

‡ Input bias currents of a FET-input operational amplifier are normal junction reverse currents, which are temperature sensitive as shown in Figure 18. Pulse techniques must be used that will maintain the junction temperature as close to the ambient temperature as possible.

TL081M, TL082M, TL084M JFET-INPUT OPERATIONAL AMPLIFIERS

SLOS081A–D2297, FEBRUARY 1977–REVISED NOVEMBER 1992

electrical characteristics, $V_{CC} \pm = \pm 15 \text{ V}$ (unless otherwise noted)

PARAMETER	TEST CONDITIONST	TL081M, TL082M			TL084M			UNIT
		MIN	TYP	MAX	MIN	TYP	MAX	
V_{IO} Input offset voltage	$V_O = 0, R_S = 50 \Omega$ $T_A = 25^\circ\text{C}$ $T_A = -55^\circ\text{C to } 125^\circ\text{C}$		3	6		3	9	mV
α_{VIO} Temperature coefficient of input offset voltage	$V_O = 0, R_S = 50 \Omega$ $T_A = -55^\circ\text{C to } 125^\circ\text{C}$		18			18		$\mu\text{V}/^\circ\text{C}$
I_{IO} Input offset current†	$V_O = 0$ $T_A = 25^\circ\text{C}$ $T_A = 125^\circ\text{C}$		5	100		5	100	pA
I_{IB} Input bias current†	$V_O = 0$ $T_A = 25^\circ\text{C}$ $T_A = 125^\circ\text{C}$		30	200		30	200	pA
V_{ICR} Common-mode input voltage range	$T_A = 25^\circ\text{C}$	± 11	± 12 to 15		± 11	± 12 to 15		V
V_{OM} Maximum peak output voltage swing	$T_A = 25^\circ\text{C}, R_L = 10 \text{ k}\Omega$ $T_A = -55^\circ\text{C to } 125^\circ\text{C}, R_L \geq 10 \text{ k}\Omega$ $T_A = -55^\circ\text{C to } 125^\circ\text{C}, R_L \geq 2 \text{ k}\Omega$	± 12	± 13.5		± 12	± 13.5		V
A_{VD} Large-signal differential voltage amplification	$V_O = \pm 10 \text{ V}, T_A = 25^\circ\text{C}, R_L \geq 2 \text{ k}\Omega$ $V_O = \pm 10 \text{ V}, T_A = -55^\circ\text{C to } 125^\circ\text{C}, R_L \geq 2 \text{ k}\Omega$	25	200		25	200		V/mV
B_1 Unity-gain bandwidth	$T_A = 25^\circ\text{C}$		3			3		MHz
r_i Input resistance	$T_A = 25^\circ\text{C}$		10^{12}			10^{12}		Ω
CMRR Common-mode rejection ratio	$V_{IC} = V_{ICR} \text{ min}, R_S = 50 \Omega, V_O = 0, T_A = 25^\circ\text{C}$	80	86		80	86		dB
k_{SVR} Supply voltage rejection ratio ($\Delta V_{CC} / \Delta V_{IO}$)	$V_{CC} = \pm 15 \text{ V to } \pm 9 \text{ V}, R_S = 50 \Omega, V_O = 0, T_A = 25^\circ\text{C}$	80	86		80	86		dB
I_{CC} Supply current (per amplifier)	No load, $V_O = 0, T_A = 25^\circ\text{C}$	1.4	2.8		1.4	2.8		mA
V_{01}/V_{02} Crosstalk attenuation	$A_{VD} = 100, T_A = 25^\circ\text{C}$		120			120		dB

† All characteristics are measured under open-loop conditions with zero common-mode input voltage unless otherwise specified.

‡ Input bias currents of a FET-input operational amplifier are normal junction reverse currents, which are temperature sensitive as shown in Figure 18. Pulse techniques must be used that will maintain the junction temperatures as close to the ambient temperature as is possible.

operating characteristics, $V_{CC} \pm = \pm 15 \text{ V}, T_A = 25^\circ\text{C}$ (unless otherwise noted)

PARAMETER	TEST CONDITIONS	MIN	TYP	MAX	UNIT
SR Slew rate at unity gain	$V_I = 10 \text{ V}, R_L = 2 \text{ k}\Omega, C_L = 100 \text{ pF}$, See Figure 1 $V_I = 10 \text{ V}, R_L = 2 \text{ k}\Omega, C_L = 100 \text{ pF}, T_A = -55^\circ\text{C to } 125^\circ\text{C}$, See Figure 1	8*	13		V/ μs
t_r Rise time	$V_I = 20 \text{ mV}, R_L = 2 \text{ k}\Omega, C_L = 100 \text{ pF}$, See Figure 1		0.05		μs
Overshoot factor	$V_I = 20 \text{ mV}, R_L = 2 \text{ k}\Omega, C_L = 100 \text{ pF}$, See Figure 1		20%		
V_n Equivalent input noise voltage	$R_S = 100 \Omega, f = 1 \text{ kHz}$ $f = 10 \text{ Hz to } 10 \text{ kHz}$		18		nV/ $\sqrt{\text{Hz}}$
I_n Equivalent input noise current	$R_S = 100 \Omega, f = 1 \text{ kHz}$		0.01		pA/ $\sqrt{\text{Hz}}$
THD Total harmonic distortion	$V_{O(\text{rms})} = 10 \text{ V}, R_S \leq 1 \text{ k}\Omega, f = 1 \text{ kHz}, R_L \geq 2 \text{ k}\Omega$		0.003%		

*On products compliant to MIL-STD-883, Class B, this parameter is not production tested.

TL080, TL081, TL084, TL081A, TL082A, TL084A
TL081B, TL082B, TL084B
JFET-INPUT OPERATIONAL AMPLIFIERS

SLOS081A–D2297, FEBRUARY 1977–REVISED NOVEMBER 1992

TL082Y, TL084Y electrical characteristics, $V_{CC\pm} = \pm 15$ V (unless otherwise noted)

PARAMETER		TEST CONDITION [†]	MIN	TYP	MAX	UNIT
V_{IO}	Input offset voltage	$V_O = 0$, $R_S = 50 \Omega$, $T_A = 25^\circ\text{C}$		3	15	mV
α_{VIO}	Temperature coefficient of input offset voltage	$V_O = 0$, $R_S = 50 \Omega$, $T_A = 25^\circ\text{C}$		18		$\mu\text{V}/^\circ\text{C}$
I_{IO}	Input offset current [‡]	$V_O = 0$, $T_A = 25^\circ\text{C}$		5	200	pA
I_{IB}	Input bias current [‡]	$V_O = 0$, $T_A = 25^\circ\text{C}$		30	400	pA
V_{ICR}	Common-mode input voltage range	$T_A = 25^\circ\text{C}$	± 11	-12 to 15		V
V_{OM}	Maximum peak output voltage swing	$T_A = 25^\circ\text{C}$, $R_L = 10 \text{ k}\Omega$	± 12	± 13.5		V
A_{VD}	Large-signal differential voltage amplification	$V_O = \pm 10$ V, $T_A = 25^\circ\text{C}$, $R_L \geq 2 \text{ k}\Omega$	25	200		V/mV
B_1	Unity-gain bandwidth	$T_A = 25^\circ\text{C}$		3		MHz
r_i	Input resistance	$T_A = 25^\circ\text{C}$		10^{12}		Ω
CMRR	Common-mode rejection ratio	$V_{IC} = V_{ICR}$ min, $R_S = 50 \Omega$, $V_O = 0$, $T_A = 25^\circ\text{C}$	70	86		dB
k_{SVR}	Supply voltage rejection ratio ($\Delta V_{CC\pm} / \Delta V_{IO}$)	$V_{CC} = \pm 15$ V to ± 9 V, $R_S = 50 \Omega$, $V_O = 0$, $T_A = 25^\circ\text{C}$	70	86		dB
I_{CC}	Supply current (per amplifier)	No load, $V_O = 0$, $T_A = 25^\circ\text{C}$		1.4	2.8	mA
V_{O1}/V_{O2}	Crosstalk attenuation	$A_{VD} = 100$, $T_A = 25^\circ\text{C}$		120		dB

[†] All characteristics are measured under open-loop conditions with zero common-mode voltage unless otherwise specified.

[‡] Input bias currents of a FET-input operational amplifier are normal junction reverse currents, which are temperature sensitive as shown in Figure 18. Pulse techniques must be used that will maintain the junction temperature as close to the ambient temperature as possible.

operating characteristics, $V_{CC\pm} = \pm 15$ V, $T_A = 25^\circ\text{C}$ (unless otherwise noted)

PARAMETER		TEST CONDITIONS	MIN	TYP	MAX	UNIT
SR	Slew rate at unity gain	$V_I = 10$ V, $R_L = 2 \text{ k}\Omega$, $C_L = 100$ pF, See Figure 1	8	13		V/ μs
t_r	Rise time	$V_I = 20$ mV, $R_L = 2 \text{ k}\Omega$, $C_L = 100$ pF, See Figure 1		0.05		μs
	Overshoot factor			20%		
V_n	Equivalent input noise voltage	$R_S = 100 \Omega$, $f = 1 \text{ kHz}$		18		nV/ $\sqrt{\text{Hz}}$
		$f = 10 \text{ Hz to } 10 \text{ kHz}$		4		μV
I_n	Equivalent input noise current	$R_S = 100 \Omega$, $f = 1 \text{ kHz}$		0.01		pA/ $\sqrt{\text{Hz}}$
THD	Total harmonic distortion	$V_{O(\text{rms})} = 10$ V, $R_S \leq 1 \text{ k}\Omega$, $R_L \geq 2 \text{ k}\Omega$, $f = 1 \text{ kHz}$		0.003%		

TL080, TL081, TL082, TL084, TL081A, TL082A, TL084A
 TL081B, TL082B, TL084B, TL082Y, TL084Y
JFET-INPUT OPERATIONAL AMPLIFIERS
 SLOS081A–D2297, FEBRUARY 1977–REVISED NOVEMBER 1992

PARAMETER MEASUREMENT INFORMATION

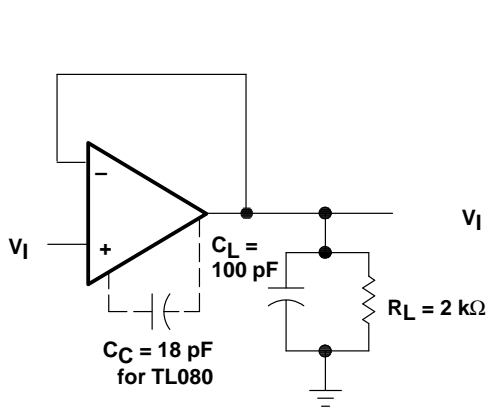

Figure 1. Unity-Gain Amplifier

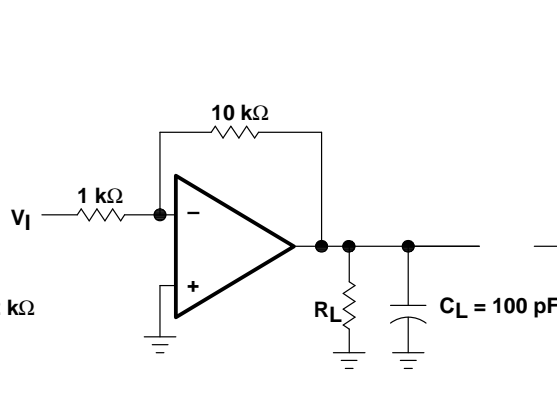

Figure 2. Gain-of-10 Inverting Amplifier

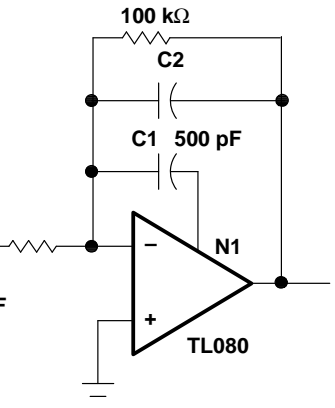

Figure 3. Feed-Forward Compensation

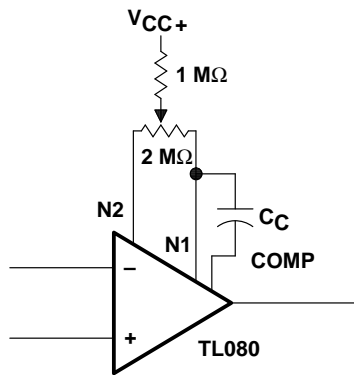

Figure 4. TL080 Input Offset Voltage Null Circuit

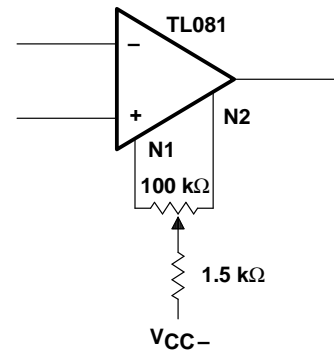

Figure 5. TL081 Input Offset Voltage Null Circuit

TL080, TL081, TL082, TL084, TL081A, TL082A, TL084A
 TL081B, TL082B, TL084B
JFET-INPUT OPERATIONAL AMPLIFIERS
 SLOS081A–D2297, FEBRUARY 1977–REVISED NOVEMBER 1992

TYPICAL CHARACTERISTICS†

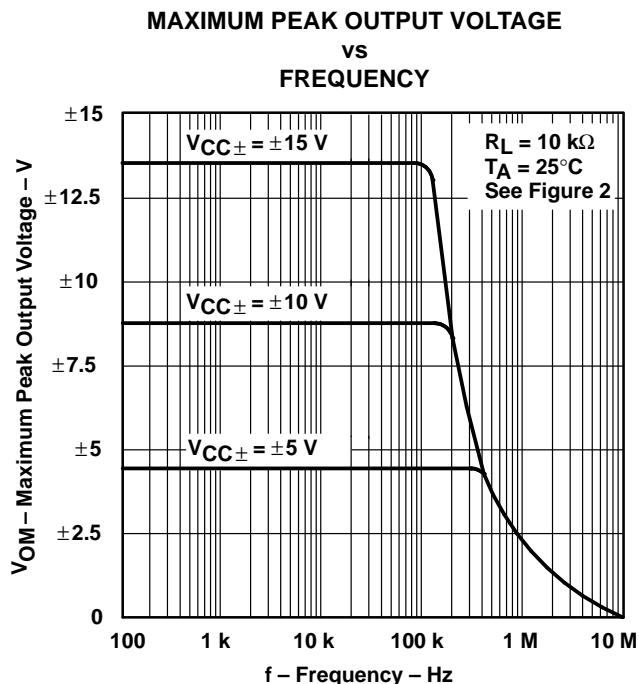

Figure 6

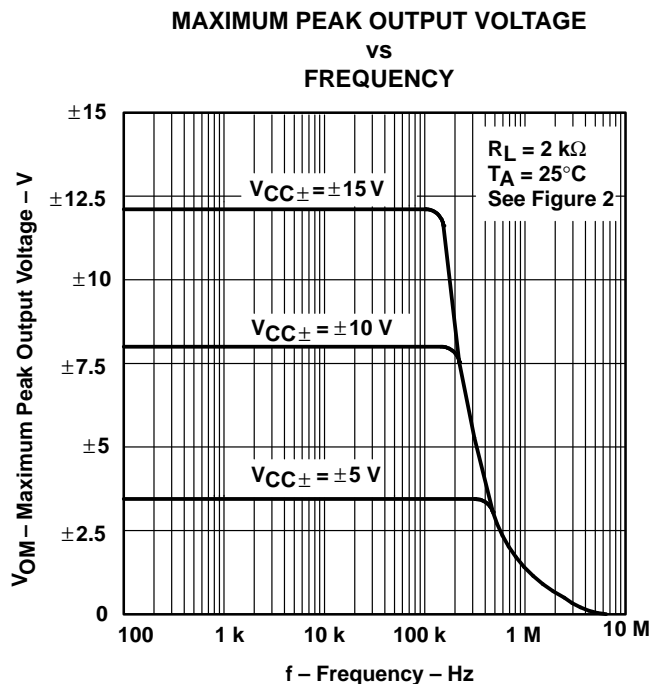

Figure 7

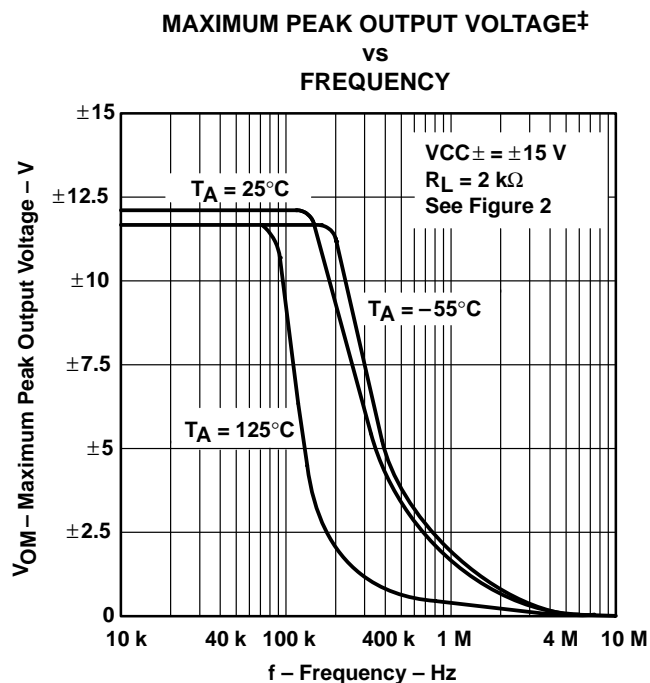

Figure 8

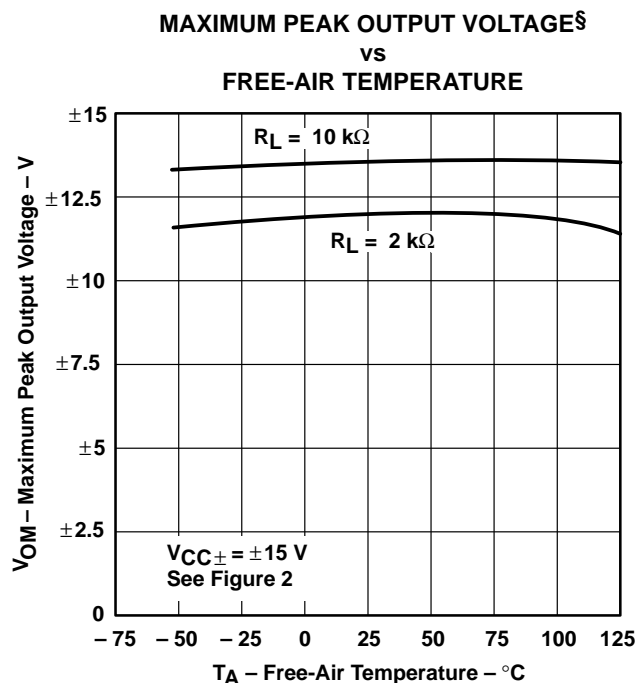

Figure 9

† Data at high and low temperatures are applicable only within the rated operating free-air temperature ranges of the various devices. A 12-pF compensation capacitor is used with TL080.

‡ The -55°C curve and the 125°C curve apply only to the M version.

§ The temperature range of the C version is 0°C to 75°C , the I version is -40°C to 85°C , and the M version is -55°C to 125°C .

TL080, TL081, TL082, TL084, TL081A, TL082A, TL084A
 TL081B, TL082B, TL084B
JFET-INPUT OPERATIONAL AMPLIFIERS
 SLOS081A–D2297, FEBRUARY 1977–REVISED NOVEMBER 1992

TYPICAL CHARACTERISTICS†

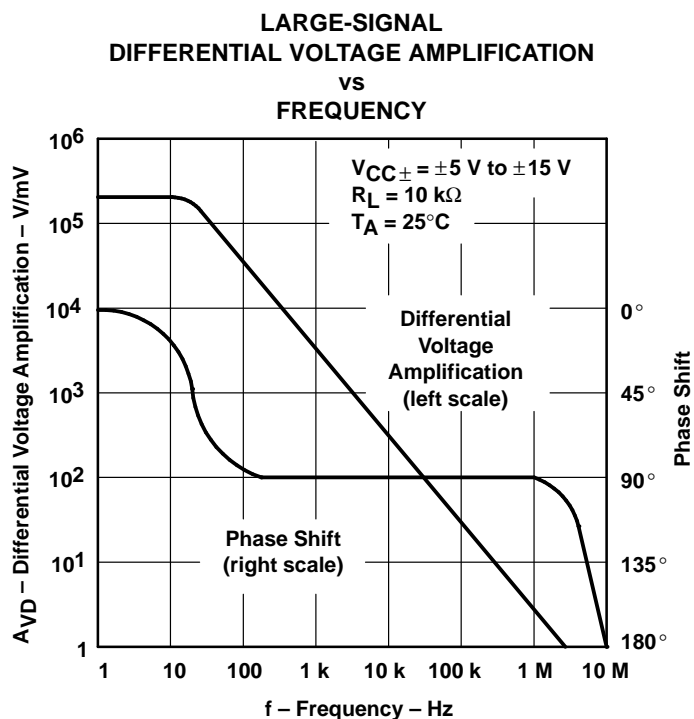
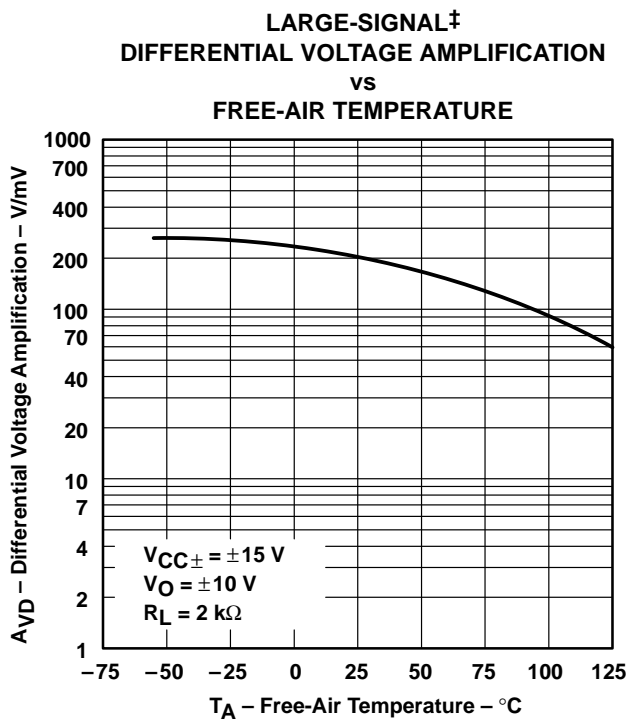
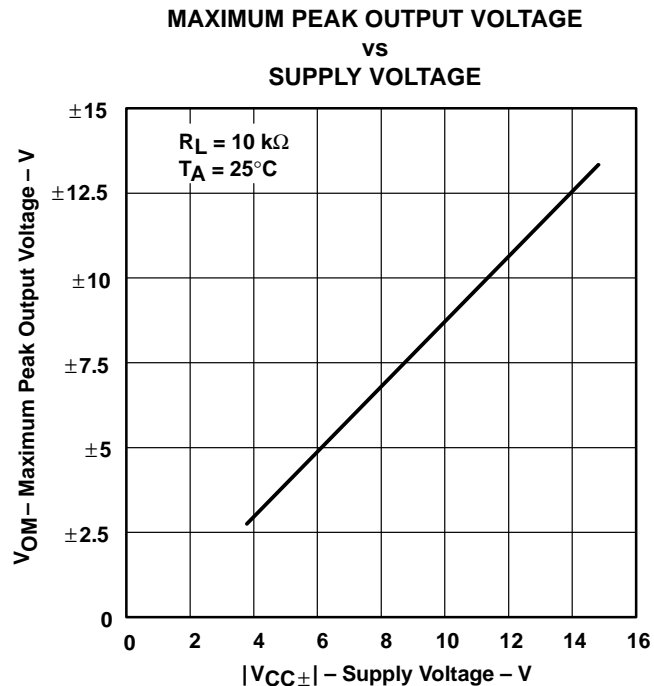
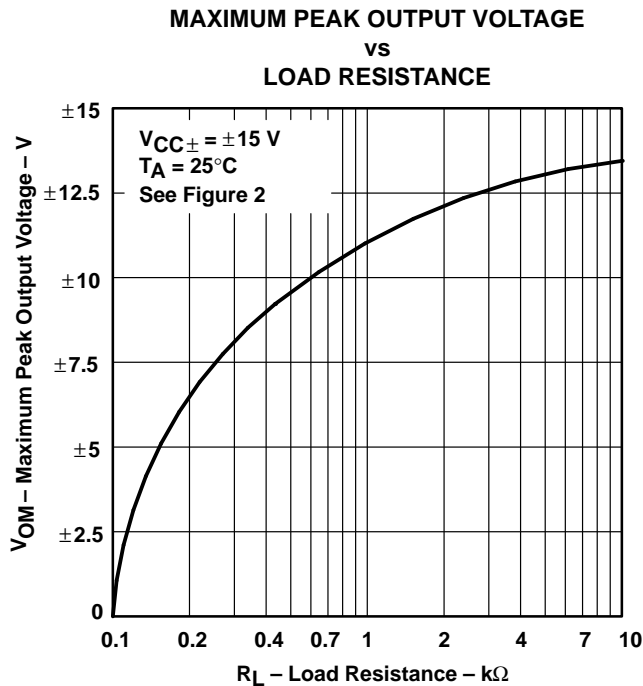

† Data at high and low temperatures are applicable only within the rated operating free-air temperature ranges of the various devices. A 12-pF compensation capacitor is used with TL080.
 ‡ The temperature range of the C version is 0°C to 75°C, the I version is -40°C to 85°C, and the M version is -55°C to 125°C.

TL080, TL081, TL082, TL084, TL081A, TL082A, TL084A
 TL081B, TL082B, TL084B
JFET-INPUT OPERATIONAL AMPLIFIERS
 SLOS081A–D2297, FEBRUARY 1977–REVISED NOVEMBER 1992

TYPICAL CHARACTERISTICS†

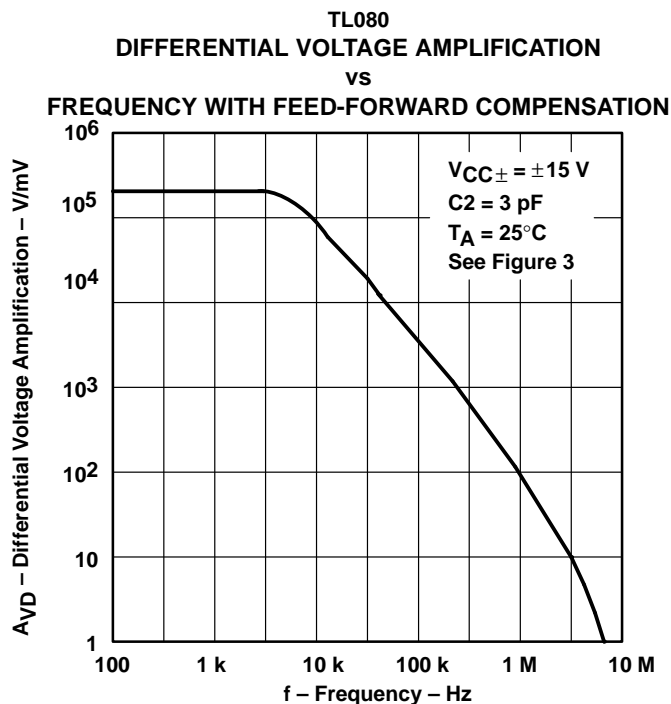

Figure 14

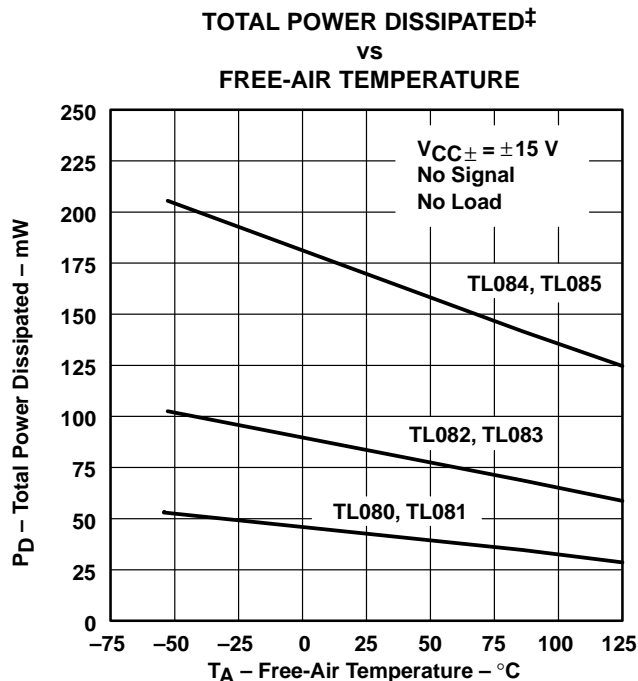

Figure 15

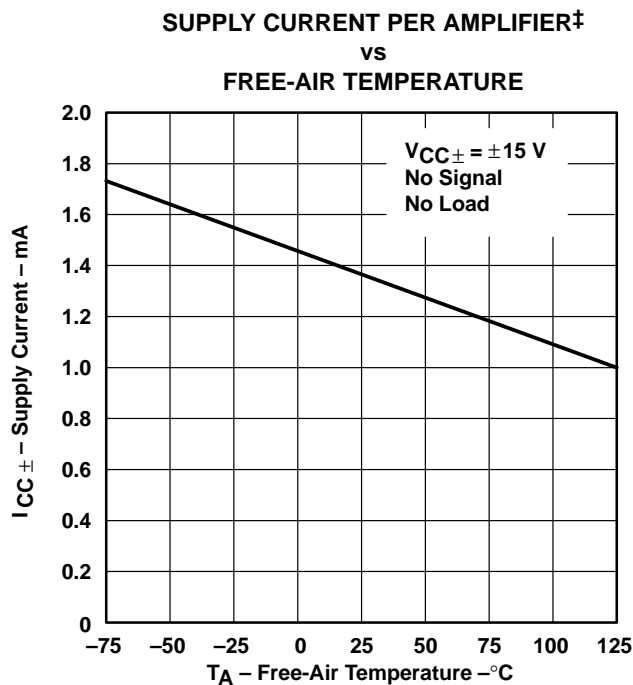

Figure 16

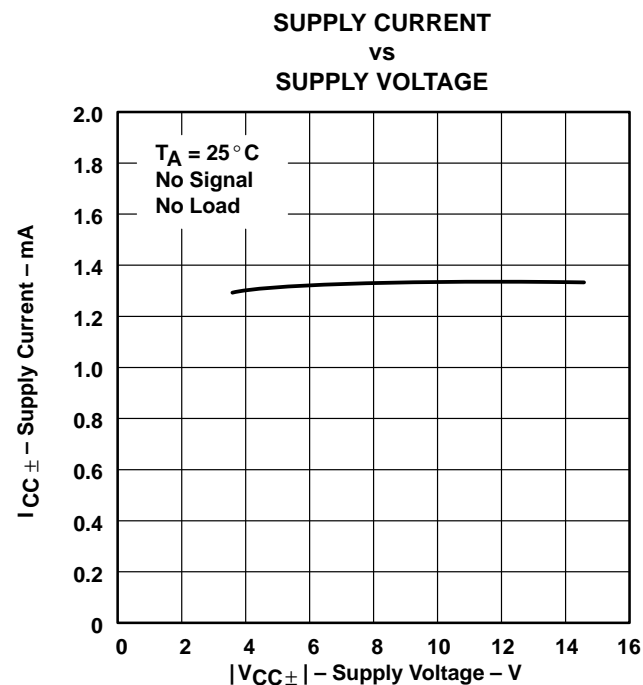

Figure 17

† Data at high and low temperatures are applicable only within the rated operating free-air temperature ranges of the various devices. A 12-pF compensation capacitor is used with TL080.

‡ The temperature range of the C version is 0°C to 75°C, the I version is -40°C to 85°C, and the M version is -55°C to 125°C.

TL080, TL081, TL082, TL084, TL081A, TL082A, TL084A
 TL081B, TL082B, TL084B
JFET-INPUT OPERATIONAL AMPLIFIERS
 SLOS081A–D2297, FEBRUARY 1977–REVISED NOVEMBER 1992

TYPICAL CHARACTERISTICS†

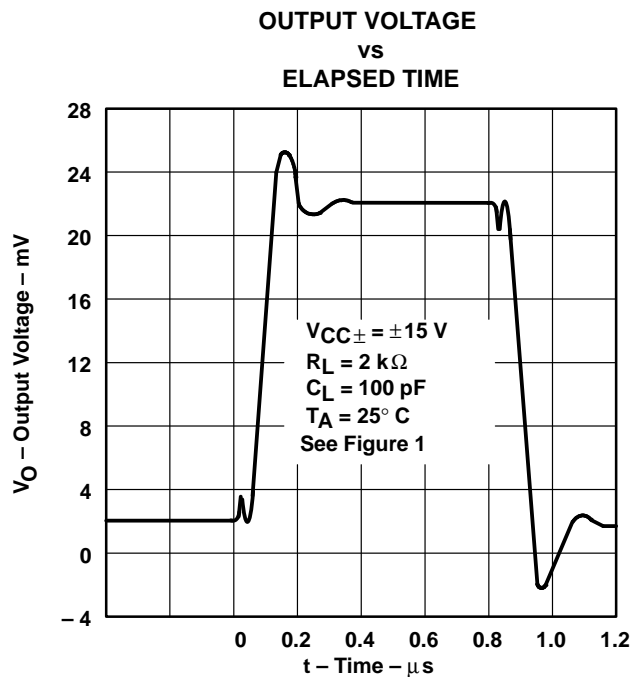
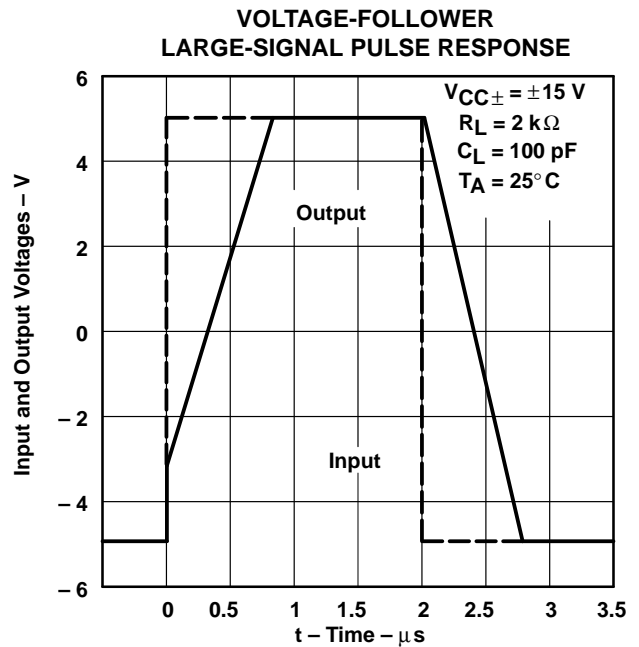
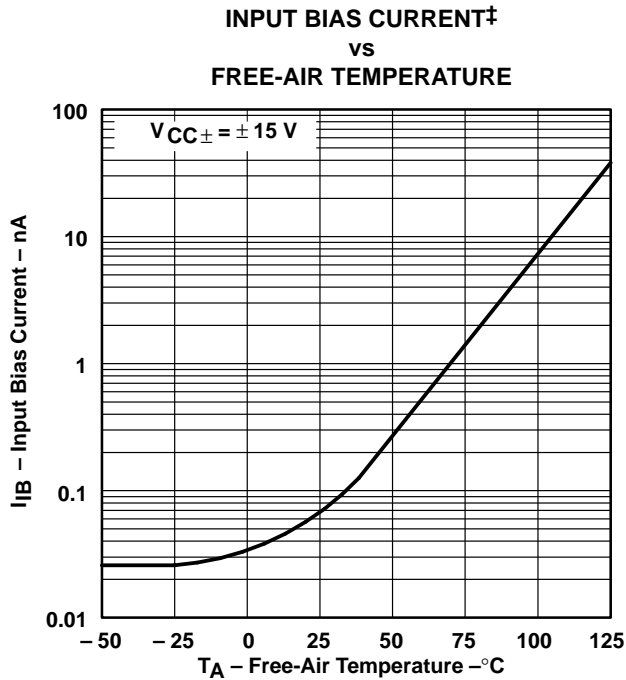

† Data at high and low temperatures are applicable only within the rated operating free-air temperature ranges of the various devices. A 12-pF compensation capacitor is used with TL080.

‡ The temperature range of the C version is 0°C to 75°C, the I version is -40°C to 85°C, and the M version is -55°C to 125°C.

TL080, TL081, TL082, TL084, TL081A, TL082A, TL084A
 TL081B, TL082B, TL084B
JFET-INPUT OPERATIONAL AMPLIFIERS
 SLOS081A–D2297, FEBRUARY 1977–REVISED NOVEMBER 1992

TYPICAL CHARACTERISTICS†

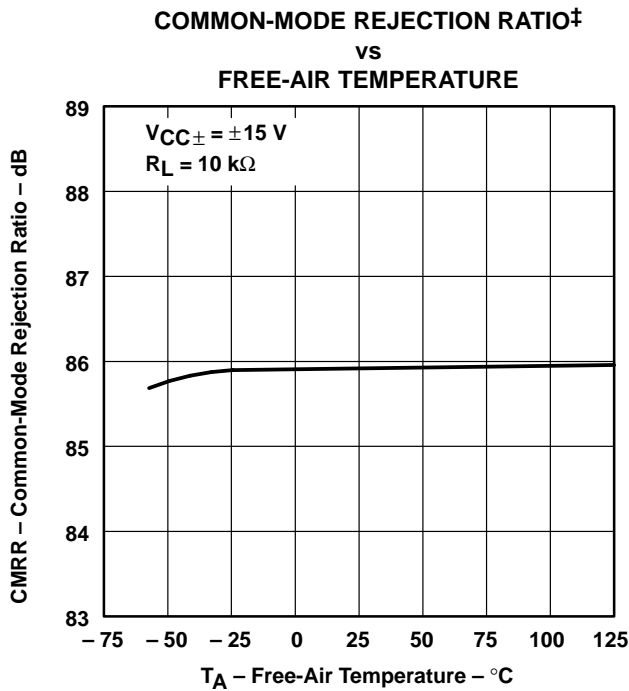

Figure 21

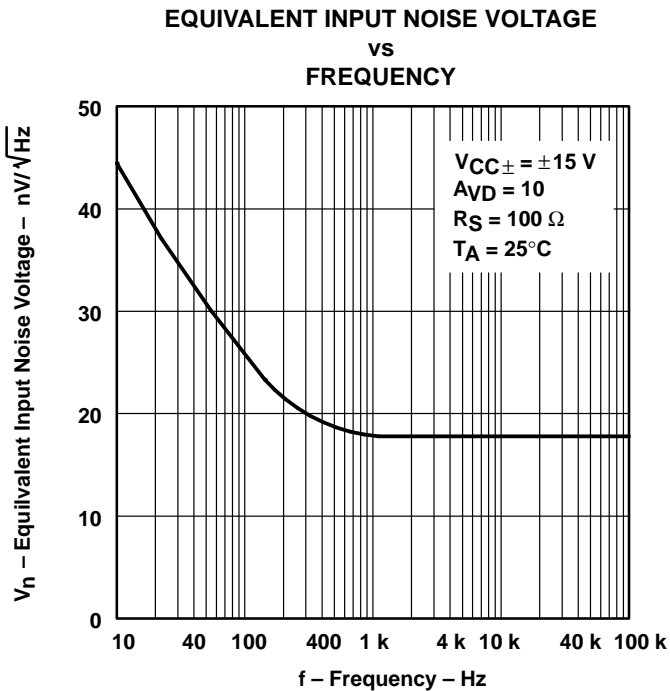

Figure 22

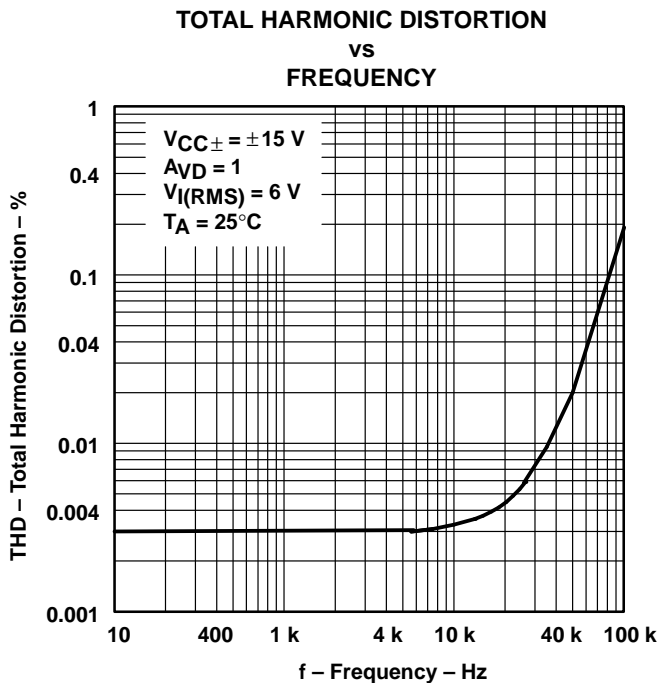

Figure 23

† Data at high and low temperatures are applicable only within the rated operating free-air temperature ranges of the various devices. A 12-pF compensation capacitor is used with TL080.

‡ The temperature range of the C version is 0°C to 75°C, the I version is –40°C to 85°C, and the M version is –55°C to 125°C.

TL080, TL081, TL082, TL084, TL081A, TL082A, TL084A
 TL081B, TL082B, TL084B
JFET-INPUT OPERATIONAL AMPLIFIERS
 SLOS081A-D2297, FEBRUARY 1977-REVISED NOVEMBER 1992

TYPICAL APPLICATION DATA

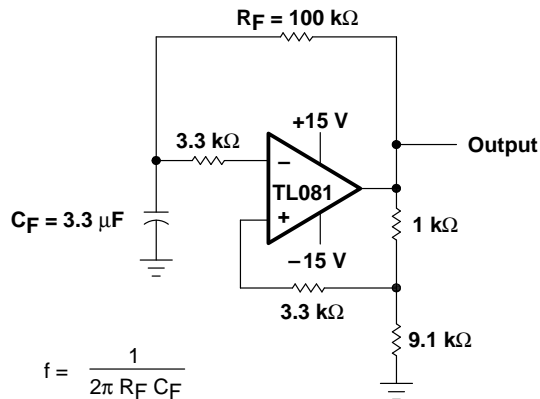

Figure 24. 0.5-Hz Square-Wave Oscillator

$$f = \frac{1}{2\pi R_F C_F}$$

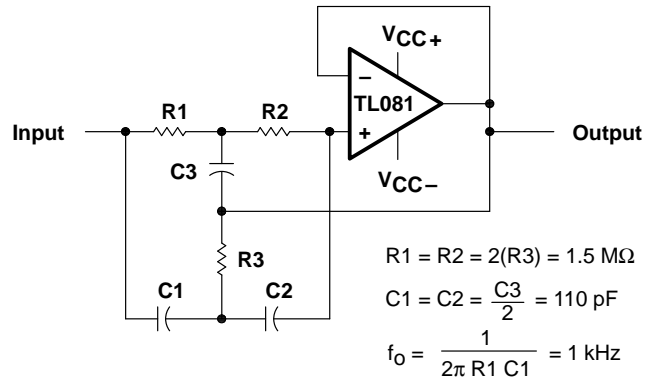

Figure 25. High-Q Notch Filter

$$R1 = R2 = 2(R3) = 1.5 \text{ M}\Omega$$

$$C1 = C2 = \frac{C3}{2} = 110 \text{ pF}$$

$$f_o = \frac{1}{2\pi R1 C1} = 1 \text{ kHz}$$

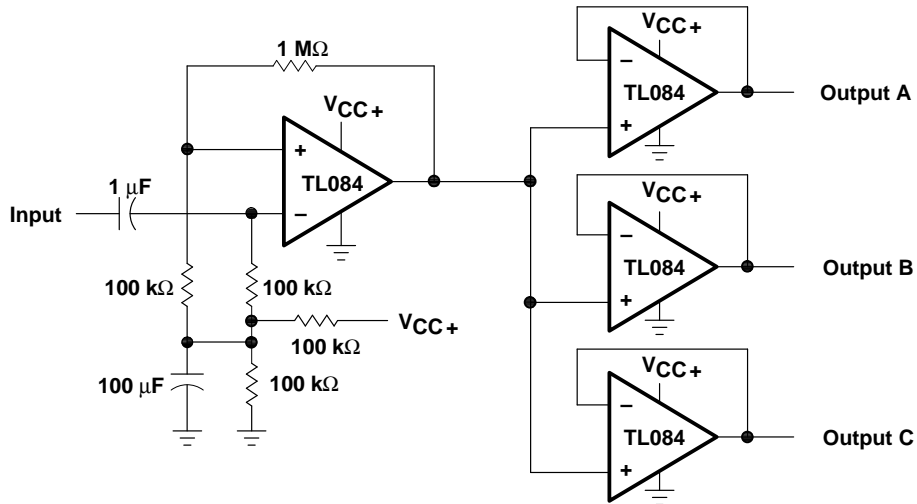
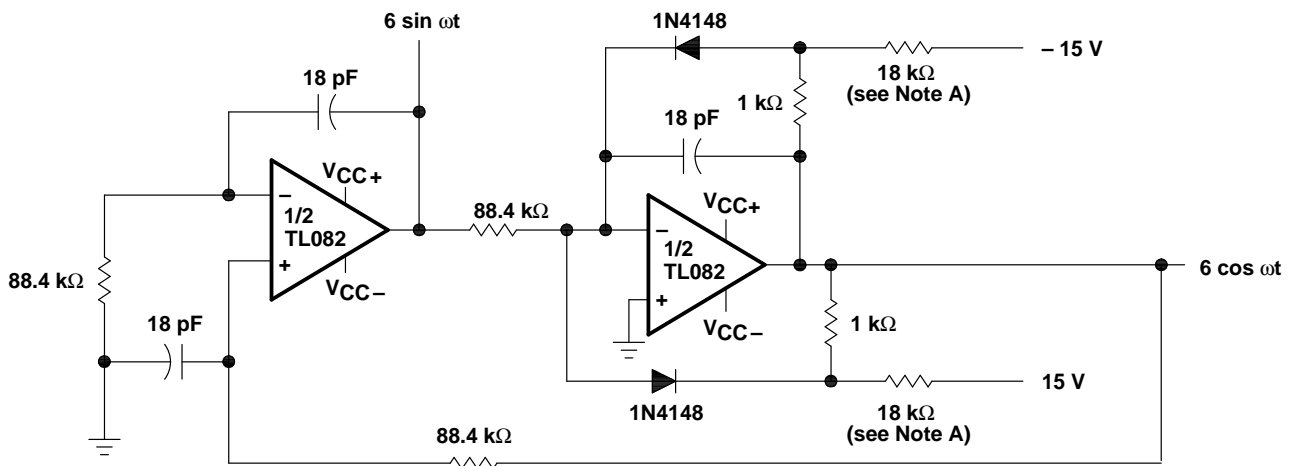

Figure 26. Audio Distribution Amplifier



NOTE A: These resistor values may be adjusted for a symmetrical output.

Figure 27. 100-KHz Quadrature Oscillator

TL080, TL081, TL082, TL084, TL081A, TL082A, TL084A
 TL081B, TL082B, TL084B
JFET-INPUT OPERATIONAL AMPLIFIERS
 SLOS081A-D2297, FEBRUARY 1977-REVISED NOVEMBER 1992

TYPICAL APPLICATION DATA

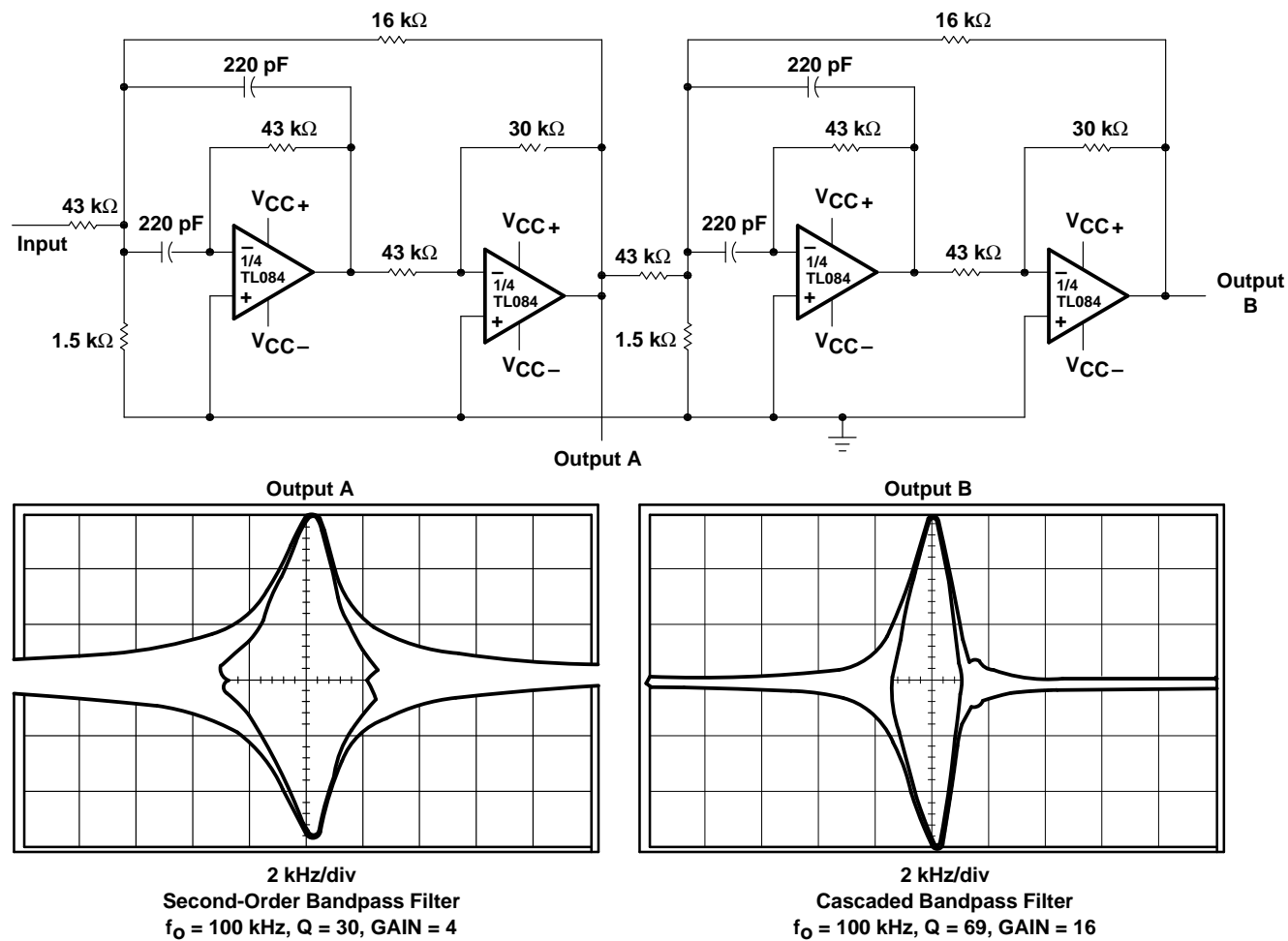

Figure 28. Positive-Feedback Bandpass Filter

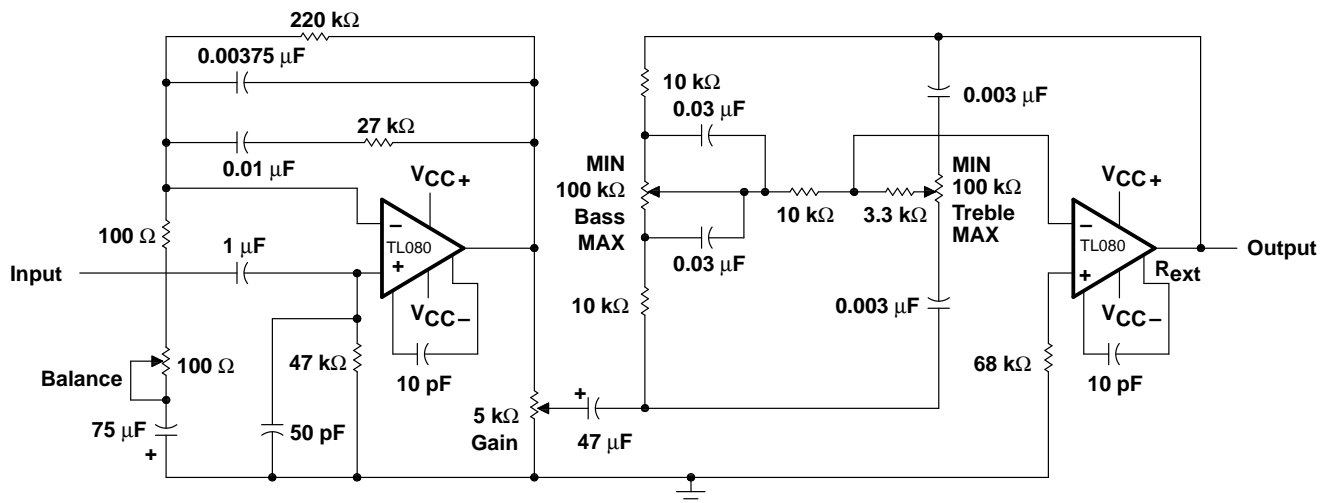

Figure 29. IC Preamplifier

IMPORTANT NOTICE

Texas Instruments (TI) reserves the right to make changes to its products or to discontinue any semiconductor product or service without notice, and advises its customers to obtain the latest version of relevant information to verify, before placing orders, that the information being relied on is current.

TI warrants performance of its semiconductor products and related software to the specifications applicable at the time of sale in accordance with TI's standard warranty. Testing and other quality control techniques are utilized to the extent TI deems necessary to support this warranty. Specific testing of all parameters of each device is not necessarily performed, except those mandated by government requirements.

Certain applications using semiconductor products may involve potential risks of death, personal injury, or severe property or environmental damage ("Critical Applications").

TI SEMICONDUCTOR PRODUCTS ARE NOT DESIGNED, INTENDED, AUTHORIZED, OR WARRANTED TO BE SUITABLE FOR USE IN LIFE-SUPPORT APPLICATIONS, DEVICES OR SYSTEMS OR OTHER CRITICAL APPLICATIONS.

Inclusion of TI products in such applications is understood to be fully at the risk of the customer. Use of TI products in such applications requires the written approval of an appropriate TI officer. Questions concerning potential risk applications should be directed to TI through a local SC sales office.

In order to minimize risks associated with the customer's applications, adequate design and operating safeguards should be provided by the customer to minimize inherent or procedural hazards.

TI assumes no liability for applications assistance, customer product design, software performance, or infringement of patents or services described herein. Nor does TI warrant or represent that any license, either express or implied, is granted under any patent right, copyright, mask work right, or other intellectual property right of TI covering or relating to any combination, machine, or process in which such semiconductor products or services might be or are used.