



TL081

General purpose JFET single operational amplifiers

Features

- Wide common-mode (up to V_{CC}^+) and differential voltage range
- Low input bias and offset current
- Output short-circuit protection
- High input impedance JFET input stage
- Internal frequency compensation
- Latch-up free operation
- High slew rate: 16 V/ μ s (typ)

Description

The TL081, TL081A and TL081B are high-speed JFET input single operational amplifiers incorporating well matched, high-voltage JFET and bipolar transistors in a monolithic integrated circuit.

The devices feature high slew rates, low input bias and offset currents, and low offset voltage temperature coefficient.

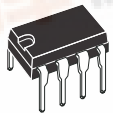

N
DIP8
(Plastic package)



D
SO-8
(Plastic micropackage)

Pin connections
(top view)

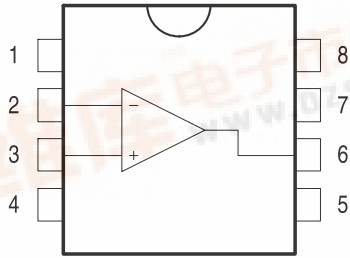

1 - Offset null 1
2 - Inverting input
3 - Non-inverting input
4 - V_{CC}^-
5 - Offset null 2
6 - Output
7 - V_{CC}^+
8 - N.C.



1 Schematic diagram

Figure 1. Schematic diagram

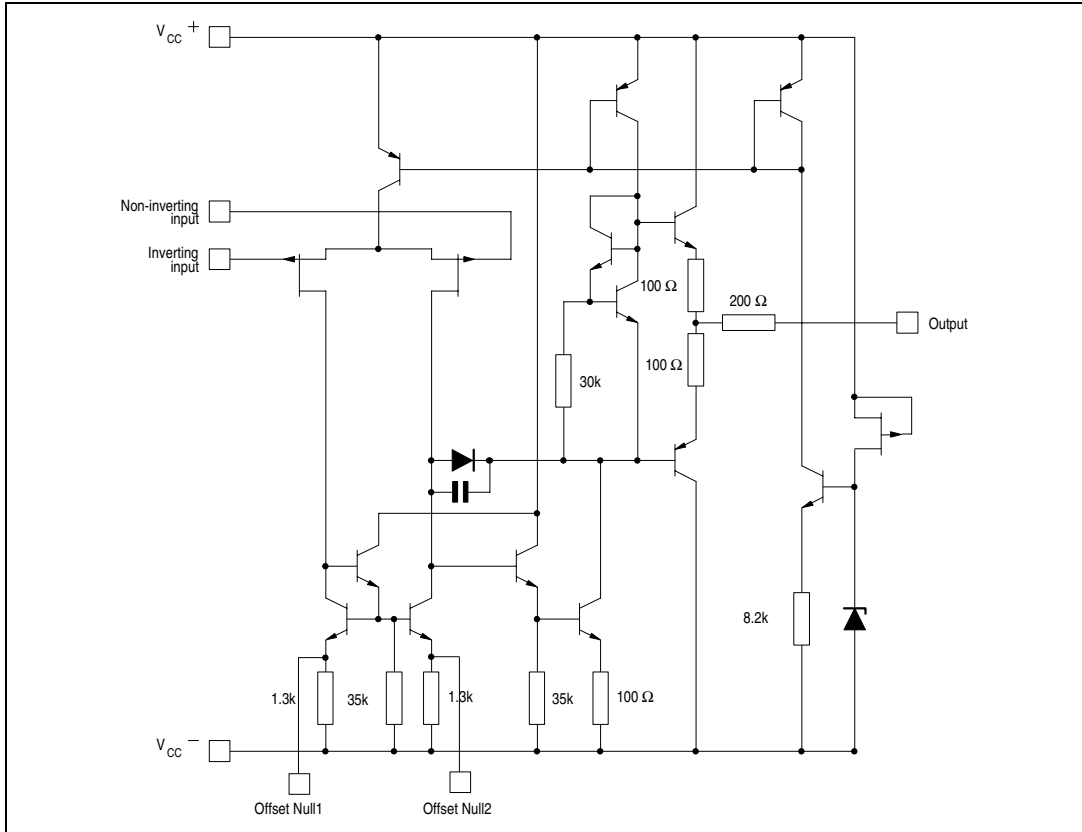
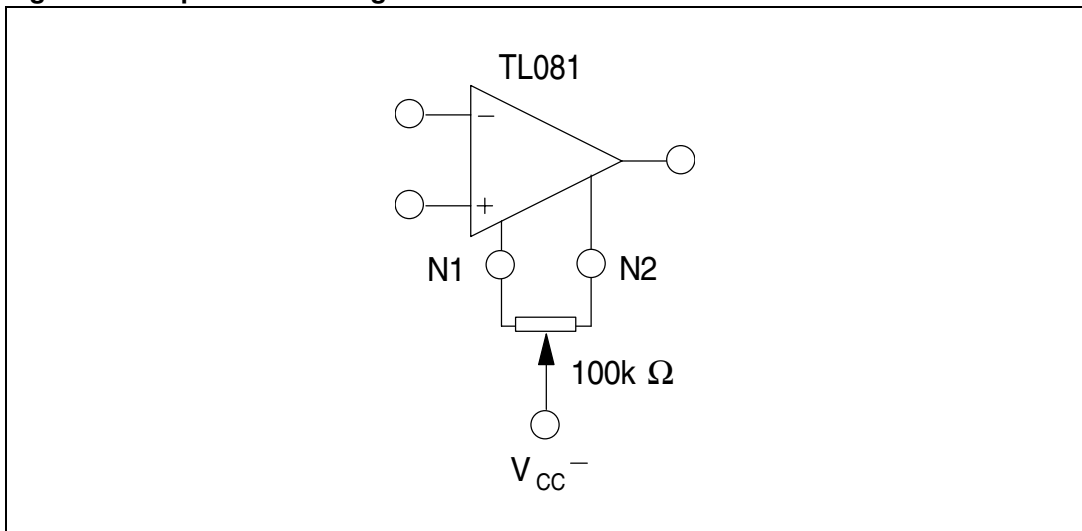

Figure 2. Input offset voltage null circuit



2 Absolute maximum ratings

Table 1. Absolute maximum ratings

Symbol	Parameter	TL081I, AI, BI	TL081C, AC, BC	Unit
V_{CC}	Supply voltage ⁽¹⁾	±18		V
V_{in}	Input voltage ⁽²⁾	±15		V
V_{id}	Differential input voltage ⁽³⁾	±30		V
P_{tot}	Power dissipation	680		mW
	Output short-circuit duration ⁽⁴⁾	Infinite		
T_{stg}	Storage temperature range	-65 to +150		°C
R_{thja}	Thermal resistance junction to ambient ^{(5) (6)}			°C/W
	SO-8 DIP8	125 85		
R_{thjc}	Thermal resistance junction to case ^{(5) (6)}			°C/W
	SO-8 DIP8	40 41		
ESD	HBM: human body model ⁽⁷⁾	500		V
	MM: machine model ⁽⁸⁾	200		V
	CDM: charged device model ⁽⁹⁾	1.5		kV

- All voltage values, except differential voltage, are with respect to the zero reference level (ground) of the supply voltages where the zero reference level is the midpoint between V_{CC}^+ and V_{CC}^- .
- The magnitude of the input voltage must never exceed the magnitude of the supply voltage or 15 volts, whichever is less.
- Differential voltages are the non-inverting input terminal with respect to the inverting input terminal.
- The output may be shorted to ground or to either supply. Temperature and/or supply voltages must be limited to ensure that the dissipation rating is not exceeded.
- Short-circuits can cause excessive heating and destructive dissipation.
- R_{th} are typical values.
- Human body model: 100 pF discharged through a 1.5kΩ resistor between two pins of the device, done for all couples of pin combinations with other pins floating.
- Machine model: a 200 pF cap is charged to the specified voltage, then discharged directly between two pins of the device with no external series resistor (internal resistor < 5 Ω), done for all couples of pin combinations with other pins floating.
- Charged device model: all pins plus package are charged together to the specified voltage and then discharged directly to the ground.

Table 2. Operating conditions

Symbol	Parameter	TL081I, AI, BI	TL081C, AC, BC	Unit
V_{CC}	Supply voltage range	6 to 36		V
T_{oper}	Operating free-air temperature range	-40 to +105	0 to +70	°C

3 Electrical characteristics

Table 3. $V_{CC} = \pm 15V$, $T_{amb} = +25^\circ C$ (unless otherwise specified)

Symbol	Parameter	TL081I, AC, AI, BC, BI			TL081C			Unit
		Min.	Typ.	Max.	Min.	Typ.	Max.	
V_{io}	Input offset voltage ($R_S = 50\Omega$) $T_{amb} = +25^\circ C$		3	10		3	10	mV
	TL081 TL081A TL081B		3 1	6 3				
	$T_{min} \leq T_{amb} \leq T_{max}$			13		13		
DV_{io}	Input offset voltage drift		10			10		$\mu V/^\circ C$
I_{io}	Input offset current ⁽¹⁾ $T_{amb} = +25^\circ C$		5	100		5	100	pA
	$T_{min} \leq T_{amb} \leq T_{max}$			4		10		nA
I_{ib}	Input bias current ⁽¹⁾ $T_{amb} = +25^\circ C$		20	200		20	400	nA
	$T_{min} \leq T_{amb} \leq T_{max}$			20		20	20	
A_{vd}	Large signal voltage gain ($R_L = 2k\Omega$, $V_o = \pm 10V$) $T_{amb} = +25^\circ C$	50	200		25	200		V/mV
	$T_{min} \leq T_{amb} \leq T_{max}$	25			15			
SVR	Supply voltage rejection ratio ($R_S = 50\Omega$) $T_{amb} = +25^\circ C$	80	86		70	86		dB
	$T_{min} \leq T_{amb} \leq T_{max}$	80			70			
I_{CC}	Supply current, no load $T_{amb} = +25^\circ C$		1.4	2.5		1.4	2.5	mA
	$T_{min} \leq T_{amb} \leq T_{max}$			2.5		2.5		
V_{icm}	Input common mode voltage range	± 11	+15 -12		± 11	+15 -12		V
CMR	Common mode rejection ratio ($R_S = 50\Omega$) $T_{amb} = +25^\circ C$	80	86		70	86		dB
	$T_{min} \leq T_{amb} \leq T_{max}$	80			70			
I_{os}	Output short-circuit current $T_{amb} = +25^\circ C$	10	40	60	10	40	60	mA
	$T_{min} \leq T_{amb} \leq T_{max}$	10		60	10		60	
$\pm V_{opp}$	Output voltage swing $T_{amb} = +25^\circ C$	10	12		10	12		V
	$R_L = 2k\Omega$	12	13.5		12	13.5		
	$R_L = 10k\Omega$	10			10			
	$T_{min} \leq T_{amb} \leq T_{max}$	12			12			
SR	Slew rate ($T_{amb} = +25^\circ C$) $V_{in} = 10V$, $R_L = 2k\Omega$, $C_L = 100pF$, unity gain	8	16		8	16		V/ μs

Table 3. $V_{CC} = \pm 15V$, $T_{amb} = +25^{\circ}C$ (unless otherwise specified) (continued)

Symbol	Parameter	TL081I, AC, AI, BC, BI			TL081C			Unit
		Min.	Typ.	Max.	Min.	Typ.	Max.	
t_r	Rise time ($T_{amb} = +25^{\circ}C$) $V_{in} = 20mV$, $R_L = 2k\Omega$, $C_L = 100pF$, unity gain		0.1			0.1		μs
K_{ov}	Overshoot ($T_{amb} = +25^{\circ}C$) $V_{in} = 20mV$, $R_L = 2k\Omega$, $C_L = 100pF$, unity gain		10			10		%
GBP	Gain bandwidth product ($T_{amb} = +25^{\circ}C$) $V_{in} = 10mV$, $R_L = 2k\Omega$, $C_L = 100pF$, $F = 100kHz$	2.5	4		2.5	4		MHz
R_i	Input resistance		10^{12}			10^{12}		Ω
THD	Total harmonic distortion ($T_{amb} = +25^{\circ}C$), $F = 1kHz$, $R_L = 2k\Omega$, $C_L = 100pF$, $A_v = 20dB$, $V_o = 2V_{pp}$		0.01			0.01		%
e_n	Equivalent input noise voltage $R_S = 100\Omega$, $F = 1kHz$		15			15		$\frac{nV}{\sqrt{Hz}}$
ϕ_m	Phase margin		45			45		degrees

- The input bias currents are junction leakage currents which approximately double for every $10^{\circ}C$ increase in the junction temperature.

Figure 3. Maximum peak-to-peak output voltage versus frequency

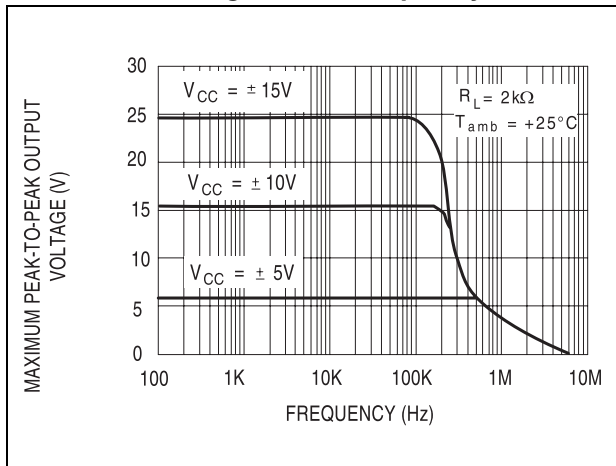

Figure 4. Maximum peak-to-peak output voltage versus frequency

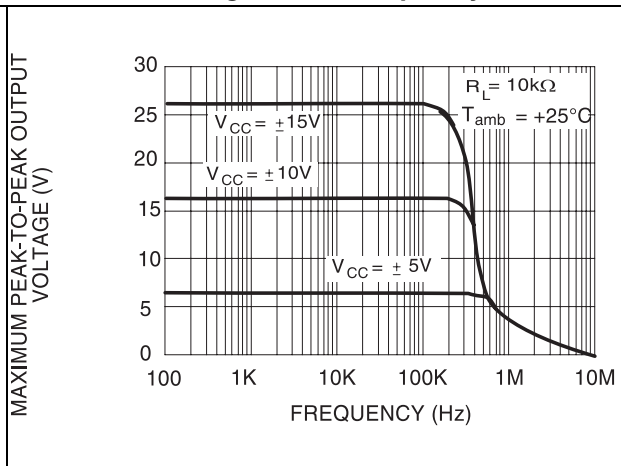

Figure 5. Maximum peak-to-peak output voltage versus frequency

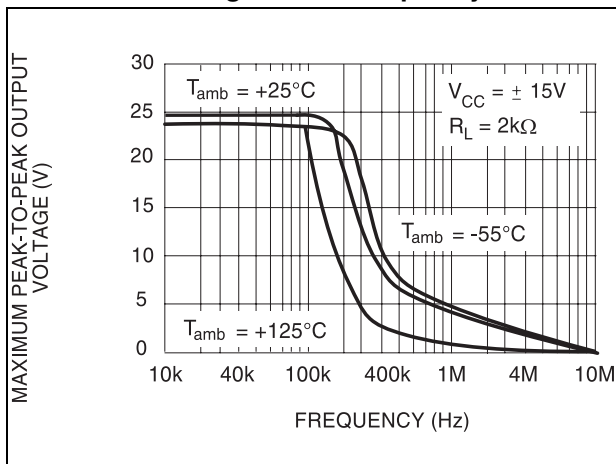

Figure 6. Maximum peak-to-peak output voltage versus free air temperature

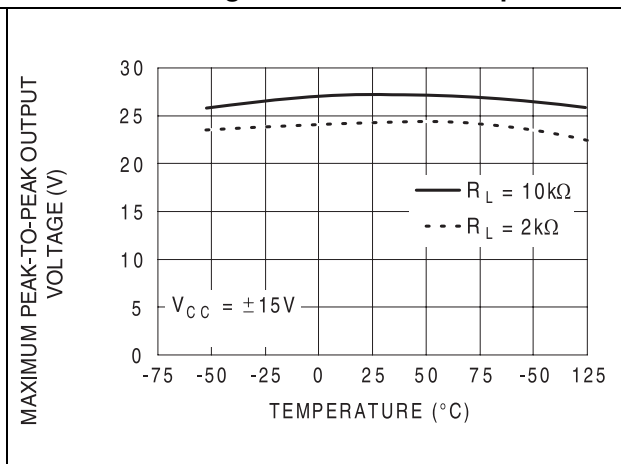

Figure 7. Maximum peak-to-peak output voltage versus load resistance

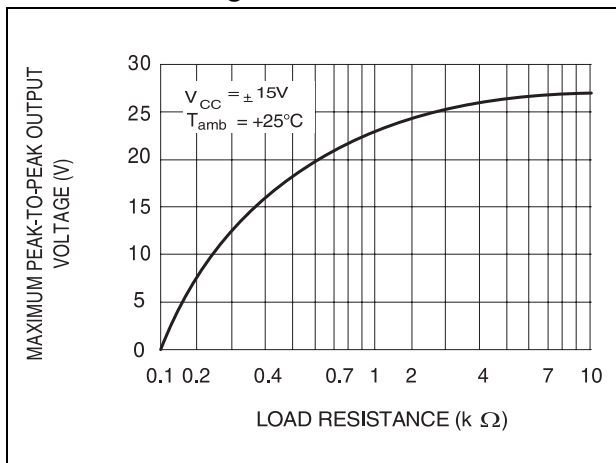

Figure 8. Maximum peak-to-peak output voltage versus supply voltage

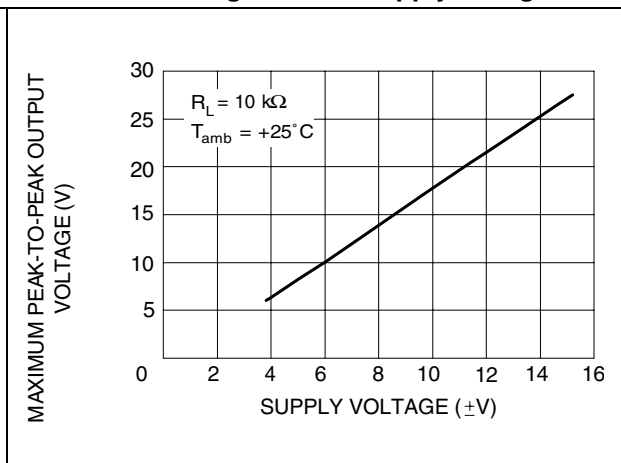

Figure 9. Input bias current versus free air temperature

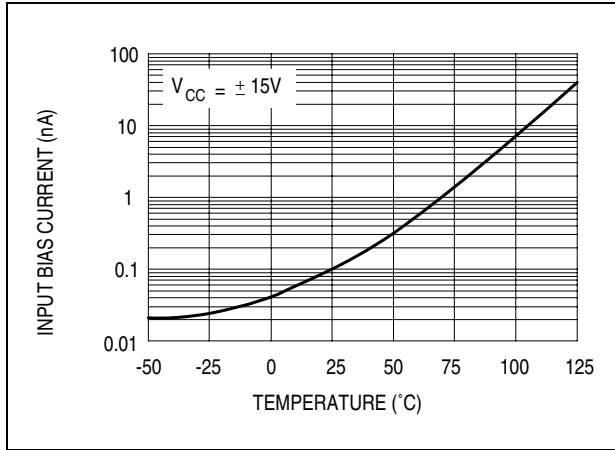

Figure 10. Large signal differential voltage amplification versus free air temp

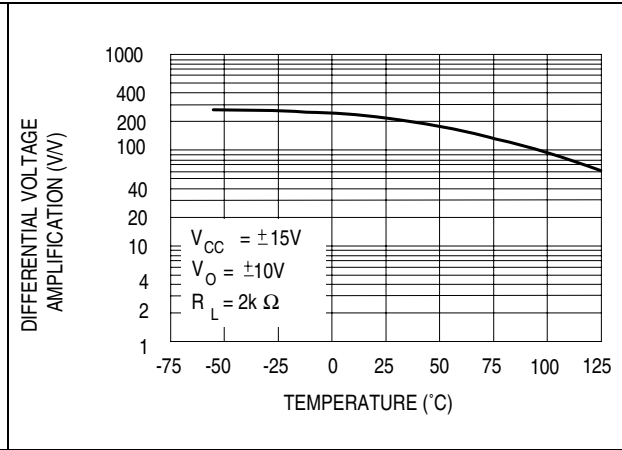

Figure 11. Large signal differential voltage amplification and phase shift versus frequency

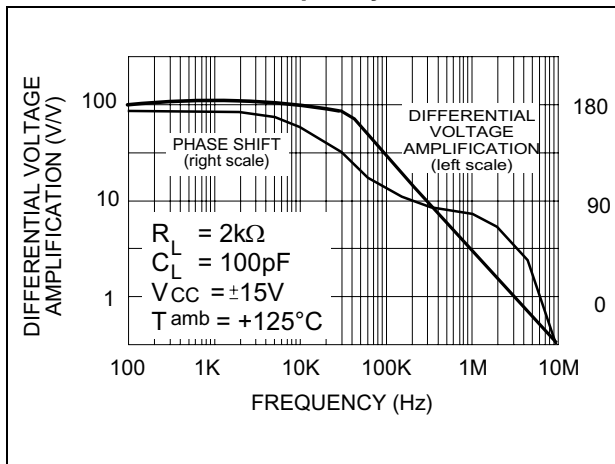

Figure 12. Total power dissipation versus free air temperature

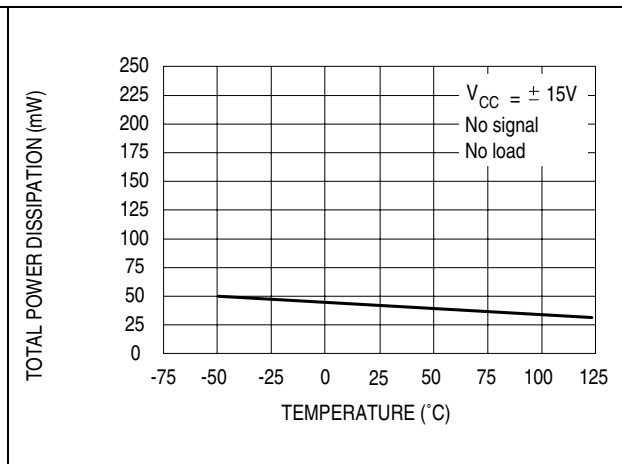

Figure 13. Supply current per amplifier versus free air temperature

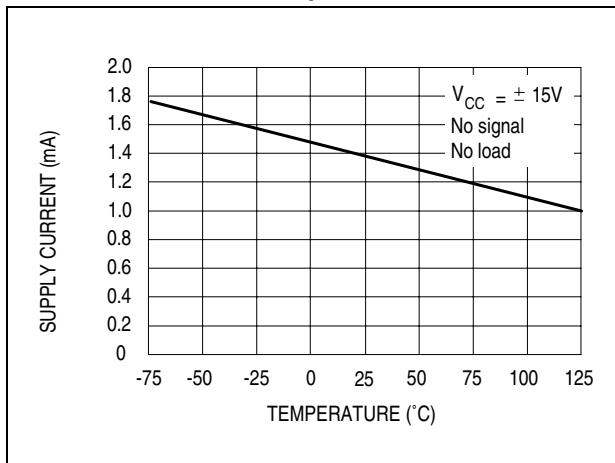

Figure 14. Supply current per amplifier versus supply voltage

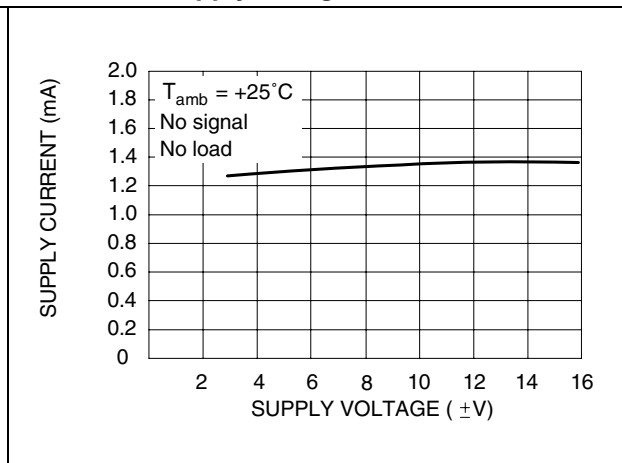

Figure 15. Common mode rejection ratio versus free air temperature

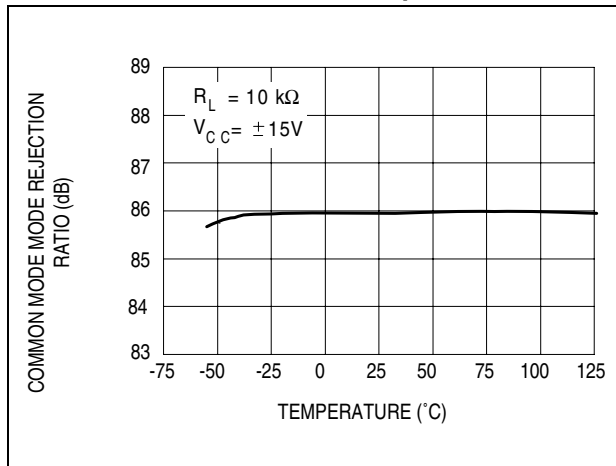

Figure 16. Equivalent input noise voltage versus frequency

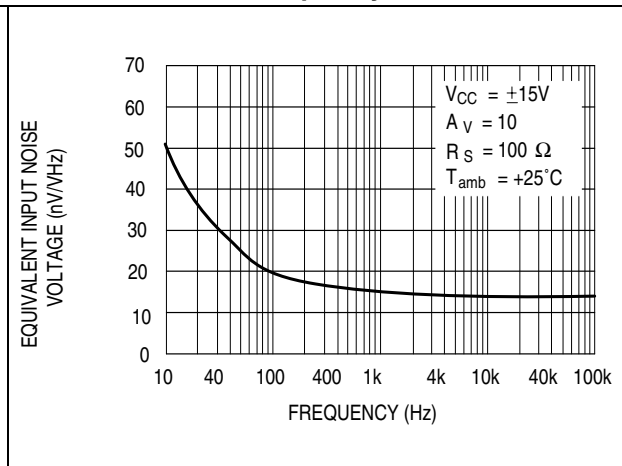

Figure 17. Output voltage versus elapsed time **Figure 18. Total harmonic distortion versus frequency**

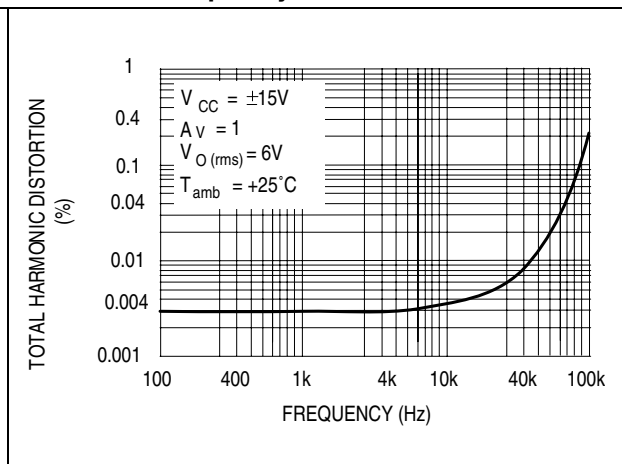
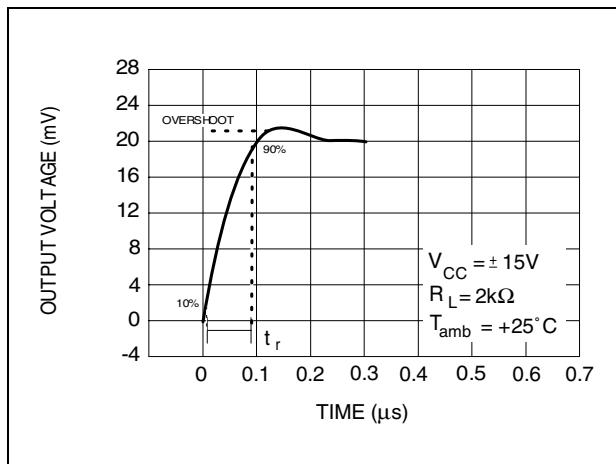
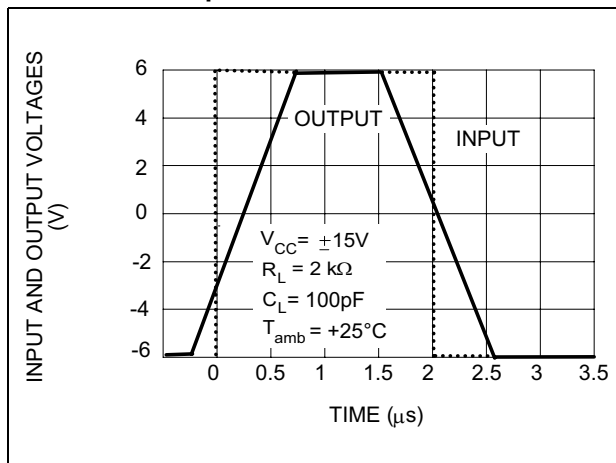

Figure 19. Voltage follower large signal pulse response



4 Parameter measurement information

Figure 20. Voltage follower

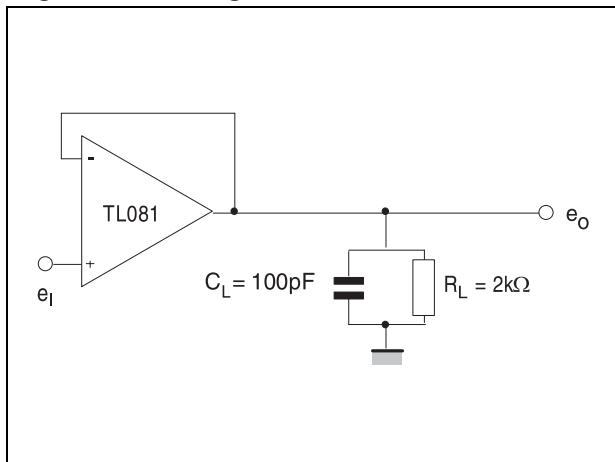
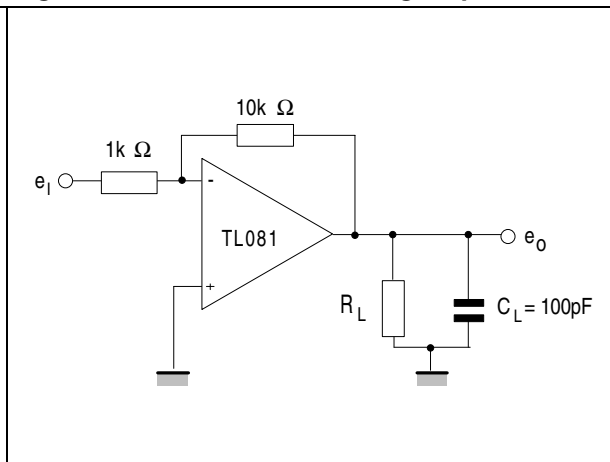

Figure 21. Gain-of-10 inverting amplifier



5 Typical applications

Figure 22. 0.5 Hz square wave oscillator

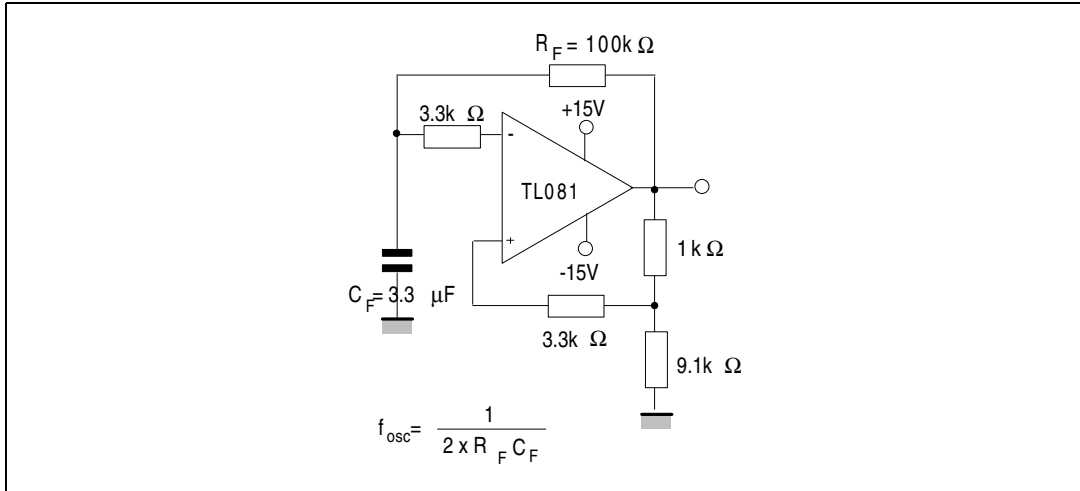
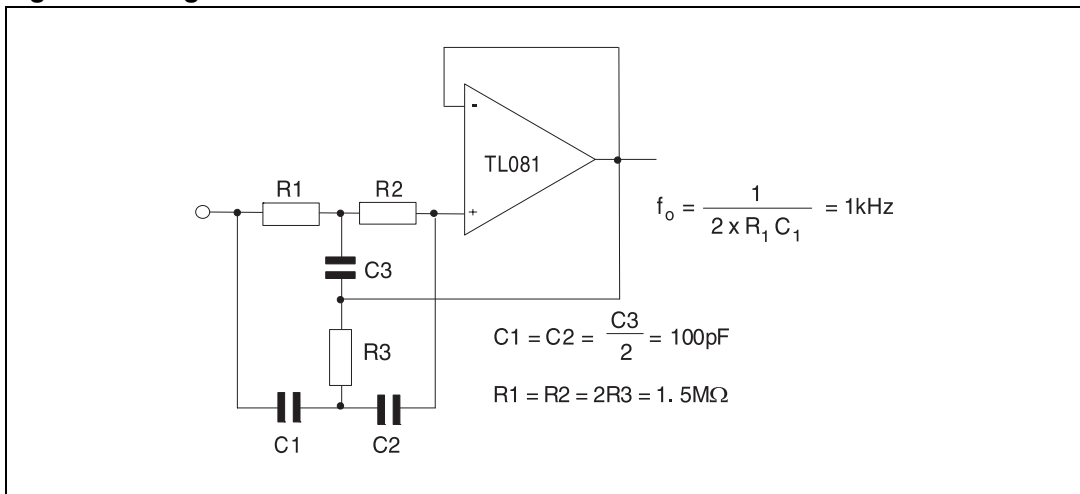

Figure 23. High Q notch filter



6 Package information

In order to meet environmental requirements, ST offers these devices in ECOPACK® packages. These packages have a lead-free second level interconnect. The category of second level interconnect is marked on the package and on the inner box label, in compliance with JEDEC Standard JESD97. The maximum ratings related to soldering conditions are also marked on the inner box label. ECOPACK is an ST trademark. ECOPACK specifications are available at: www.st.com.

6.1 DIP 8 package information

Figure 24. DIP8 package mechanical drawing

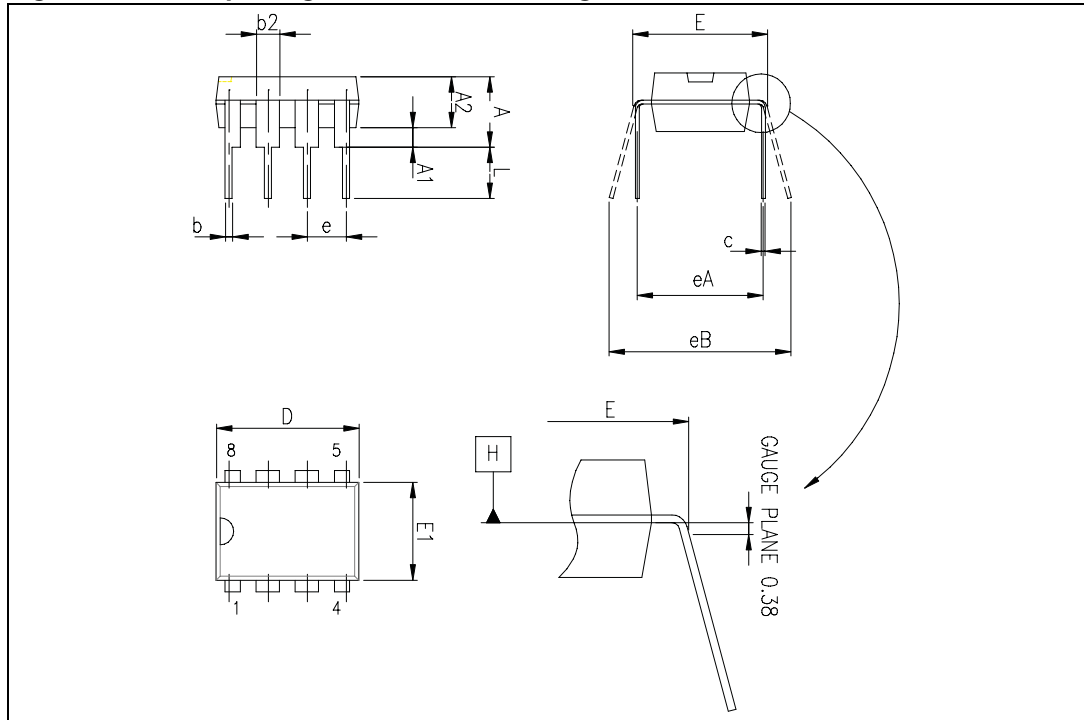

Table 4. DIP8 package mechanical data

Ref.	Dimensions					
	Millimeters			Inches		
	Min.	Typ.	Max.	Min.	Typ.	Max.
A			5.33			0.210
A1	0.38			0.015		
A2	2.92	3.30	4.95	0.115	0.130	0.195
b	0.36	0.46	0.56	0.014	0.018	0.022
b2	1.14	1.52	1.78	0.045	0.060	0.070
c	0.20	0.25	0.36	0.008	0.010	0.014
D	9.02	9.27	10.16	0.355	0.365	0.400
E	7.62	7.87	8.26	0.300	0.310	0.325
E1	6.10	6.35	7.11	0.240	0.250	0.280
e		2.54			0.100	
eA		7.62			0.300	
eB			10.92			0.430
L	2.92	3.30	3.81	0.115	0.130	0.150

6.2 SO-8 package information

Figure 25. SO-8 package mechanical drawing

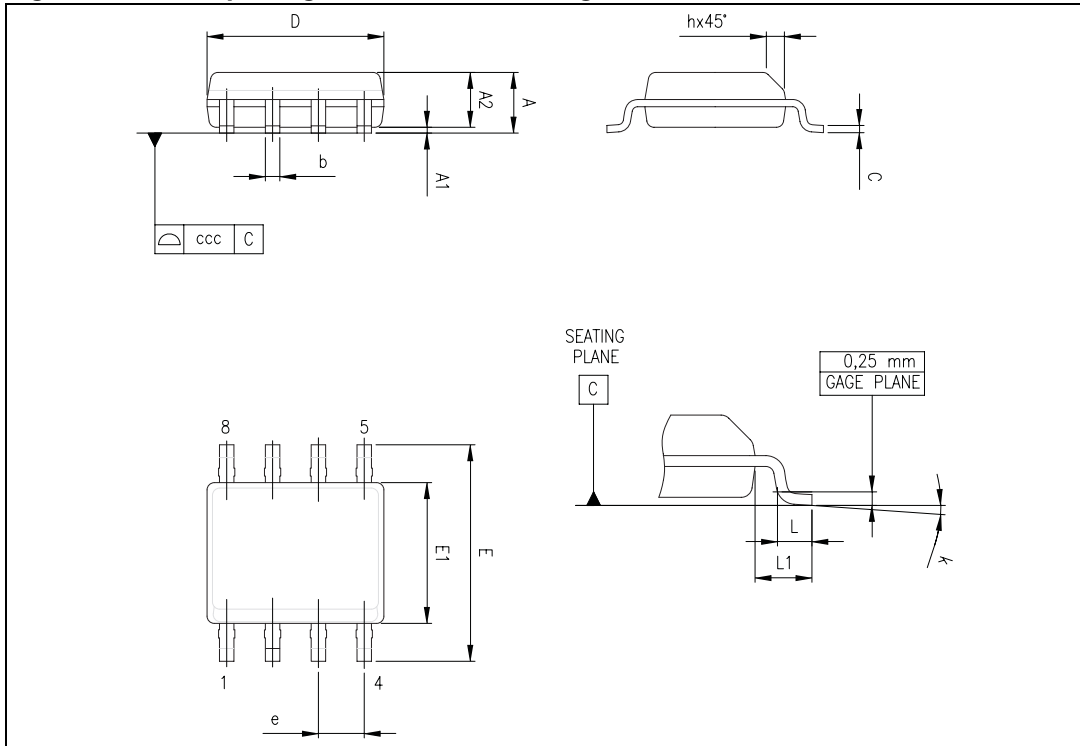

Table 5. SO-8 package mechanical data

Ref.	Dimensions					
	Millimeters			Inches		
	Min.	Typ.	Max.	Min.	Typ.	Max.
A			1.75			0.069
A1	0.10		0.25	0.004		0.010
A2	1.25			0.049		
b	0.28		0.48	0.011		0.019
c	0.17		0.23	0.007		0.010
D	4.80	4.90	5.00	0.189	0.193	0.197
E	5.80	6.00	6.20	0.228	0.236	0.244
E1	3.80	3.90	4.00	0.150	0.154	0.157
e		1.27			0.050	
h	0.25		0.50	0.010		0.020
L	0.40		1.27	0.016		0.050
k	1°		8°	1°		8°
ccc			0.10			0.004

7 Ordering information

Table 6. Order codes

Order code	Temperature range	Package	Packing	Marking
TL081IN TL081AIN TL081BIN	-40°C, +105°C	DIP8	Tube	TL081IN TL081AIN TL081BIN
TL081ID/IDT TL081AID/AIDT TL081BID/BIDT		SO-8	Tube or tape & reel	081I 081AI 081BI
TL081IYD/DT ⁽¹⁾ TL081AIYD/DT ⁽¹⁾ TL081BIYD/DT ⁽¹⁾		SO-8 (Automotive grade)	Tube or tape & reel	081IY 081AIY 081BIY
TL081CN TL081ACN TL081BCN	0°C, +70°C	DIP8	Tube	TL081CN TL081ACN TL081BCN
TL081CD/CDT TL081ACD/ACDT TL081BCD/BCDT		SO-8	Tube or tape & reel	081C 081AC 081BC

1. Qualification and characterization according to AEC Q100 and Q003 or equivalent, advanced screening according to AEC Q001 & Q 002 or equivalent are on-going.

8 Revision history

Table 7. Document revision history

Date	Revision	Changes
30-Apr-2001	1	Initial release.
27-Jul-2007	2	Added values for R_{thja} and R_{thjc} in Table 1: Absolute maximum ratings . Added Table 2: Operating conditions . Added automotive grade part numbers in Table 6: Order codes . Format update.
27-Jun-2008	3	Removed information concerning military temperature range (TL081Mx, TL081AMx, TL081BMx). Added missing order codes for automotive grade products and updated footnote in Table 6: Order codes .

Please Read Carefully:

Information in this document is provided solely in connection with ST products. STMicroelectronics NV and its subsidiaries ("ST") reserve the right to make changes, corrections, modifications or improvements, to this document, and the products and services described herein at any time, without notice.

All ST products are sold pursuant to ST's terms and conditions of sale.

Purchasers are solely responsible for the choice, selection and use of the ST products and services described herein, and ST assumes no liability whatsoever relating to the choice, selection or use of the ST products and services described herein.

No license, express or implied, by estoppel or otherwise, to any intellectual property rights is granted under this document. If any part of this document refers to any third party products or services it shall not be deemed a license grant by ST for the use of such third party products or services, or any intellectual property contained therein or considered as a warranty covering the use in any manner whatsoever of such third party products or services or any intellectual property contained therein.

UNLESS OTHERWISE SET FORTH IN ST'S TERMS AND CONDITIONS OF SALE ST DISCLAIMS ANY EXPRESS OR IMPLIED WARRANTY WITH RESPECT TO THE USE AND/OR SALE OF ST PRODUCTS INCLUDING WITHOUT LIMITATION IMPLIED WARRANTIES OF MERCHANTABILITY, FITNESS FOR A PARTICULAR PURPOSE (AND THEIR EQUIVALENTS UNDER THE LAWS OF ANY JURISDICTION), OR INFRINGEMENT OF ANY PATENT, COPYRIGHT OR OTHER INTELLECTUAL PROPERTY RIGHT.

UNLESS EXPRESSLY APPROVED IN WRITING BY AN AUTHORIZED ST REPRESENTATIVE, ST PRODUCTS ARE NOT RECOMMENDED, AUTHORIZED OR WARRANTED FOR USE IN MILITARY, AIR CRAFT, SPACE, LIFE SAVING, OR LIFE SUSTAINING APPLICATIONS, NOR IN PRODUCTS OR SYSTEMS WHERE FAILURE OR MALFUNCTION MAY RESULT IN PERSONAL INJURY, DEATH, OR SEVERE PROPERTY OR ENVIRONMENTAL DAMAGE. ST PRODUCTS WHICH ARE NOT SPECIFIED AS "AUTOMOTIVE GRADE" MAY ONLY BE USED IN AUTOMOTIVE APPLICATIONS AT USER'S OWN RISK.

Resale of ST products with provisions different from the statements and/or technical features set forth in this document shall immediately void any warranty granted by ST for the ST product or service described herein and shall not create or extend in any manner whatsoever, any liability of ST.

ST and the ST logo are trademarks or registered trademarks of ST in various countries.

Information in this document supersedes and replaces all information previously supplied.

The ST logo is a registered trademark of STMicroelectronics. All other names are the property of their respective owners.

© 2008 STMicroelectronics - All rights reserved

STMicroelectronics group of companies

Australia - Belgium - Brazil - Canada - China - Czech Republic - Finland - France - Germany - Hong Kong - India - Israel - Italy - Japan - Malaysia - Malta - Morocco - Singapore - Spain - Sweden - Switzerland - United Kingdom - United States of America

www.st.com