

**LINEAR
INTEGRATED
CIRCUITS**

WIDE TEMP

**TYPES TL091, TL092, TL094
JFET-INPUT OPERATIONAL AMPLIFIERS**
REVISED DEC. 1982

- Wide Range of Supply Voltages
Single Supply...3V to 36V
or Dual Supplies
- Class AB Output Stage
- High-Impedance N-Channel-JFET
Input Stage... $10^{12}\Omega$ typical
- Internal Frequency Compensation

- Short-Circuit Protection
- Input Common-Mode Range Includes V_{CC-}
- Low Input Offset Current...50 pA typical
- Low Input Bias Current...200 pA typical

description

The TL091 JFET input operational amplifier family is similar in performance to the MC3403 family but with much higher input impedance derived from a FET Input Stage. The N-channel-JFET input stage allows a common-mode input voltage range that includes the negative supply voltage and offers a typical input impedance of 1012 ohms, a typical input offset current of 50 picoamperes, and a typical input bias current of 200 picoamperes. The TL091 family is designed to operate from a single supply over a range of 3 to 36 volts. Operation from split supplies is also possible provided the difference between the two supplies is 3 to 36 volts. Output voltage range is from V_{CC-} to 1.5 volts less than V_{CC+} with a load resistor to V_{CC-} .

Device types with an "M" suffix are characterized for operation over the full military temperature range of -55°C to 125°C , those with an "I" suffix are characterized for operation from -25°C to 85°C , and those with a "C" suffix are characterized for operation from 0°C to 70°C .

TL091
JG OR P DUAL-IN-LINE
PACKAGE (TOP VIEW)

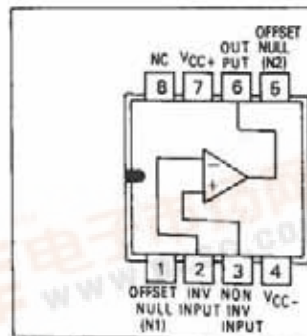

TL092
JG OR P DUAL-IN-LINE
PACKAGE (TOP VIEW)

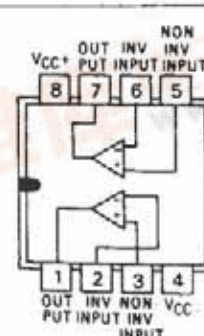

TL094
J OR N DUAL-IN-LINE
OR W PACKAGE (TOP VIEW)

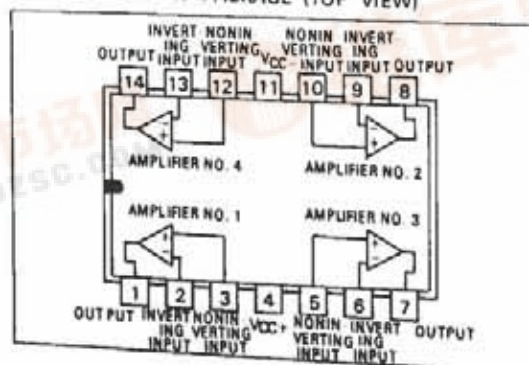

TYPES TL091, TL092, TL094 JFET-INPUT OPERATIONAL AMPLIFIERS

SCHEMATIC (EACH AMPLIFIER)

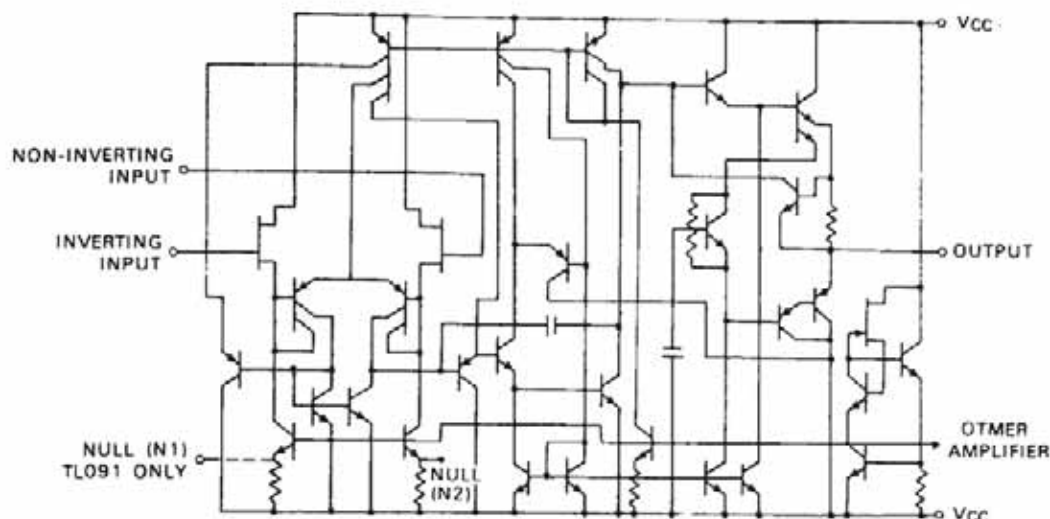

4

absolute maximum ratings over operating free-air temperature range (unless otherwise noted)

		TL091M TL092M TL094M	TL091I TL092I TL094I	TL091C TL092C TL094C	UNIT
Supply voltage V_{CC+} (see Note 1)		18	18	18	V
Supply voltage V_{CC-} (see Note 1)		-18	-18	-18	V
Supply voltage V_{CC+} with respect to V_{CC-}		36	36	36	V
Differential input voltage (see Note 2)		+36	-36	-36	V
Input voltage (see Notes 1 and 3)		± 18	± 18	± 18	V
Continuous total dissipation at (or below) 25°C free-air temperature (see Note 4)	J Package	1735	1374	1025	mW
	N Package		1150	1150	
Operating free-air temperature range		-55 to 125	40 to 85	-20 to 85	°C
Strong temperature range		-65 to 150	85 to 150	-65 to 150	°C
Lead temperature 1/16 inch (1.6mm) from case for 60seconds	J Package	300	300	300	°C
Lead temperature 1/16 inch (1.6mm) from case for 10seconds	N Package		260	260	°C

- NOTES: 1. These voltage values are with respect to the midpoint between V_{CC+} and V_{CC-} .
 2. Differential voltages are at the noninverting input terminal with respect to the inverting input terminal.
 3. Neither input must ever be more positive than V_{CC+} or more negative than V_{CC-} minus 0.3 V.
 4. For operation above 25°C free-air temperature, refer to Dissipation Derating Table. In the J package, TL094M chips are alloy-mounted; TL094I and TL094C chips are glass-mounted.

DISSIPATION DERATING TABLE

PACKAGE	POWER RATING	DERATING FACTOR	ABOVE T_A
J(Alloy-Mounted Chip)	1375mW	11.0mW/°C	25°C
J(Glass-Mounted Chips)	1025mW	8.2mW/°C	25°C
N	1150mW	9.2mW/°C	25°C
JG(Alloy-Mounted Chip)	1050mW	8.4mW/°C	25°C
JG(Glass-Mounted Chip)	825mW	6.6mW/°C	26°C
P	1000mW	8.0mW/°C	25°C

TYPES TL091, TL092, TL094 JFET-INPUT OPERATIONAL AMPLIFIERS

Characteristics, $V_{CC+} = 5V$, $V_{CC-} = 0V$, $T_A = 25^\circ C$ (unless otherwise noted)

PARAMETER	TEST CONDITIONS†	TL091M TL092M TL094M			TL091I TL092I TL094I			TL091C TL092C TL094C			UNIT
		MIN	TYP	MAX	MIN	TYP	MAX	MIN	TYP	MAX	
V_{IO} Input offset voltage	$V_O = 2.5V$, $R_S = 50\Omega$		5	9		5	9		5	9	mV
I_{IO} Input offset current‡	$V_O = 2.5V$		50	200		50	200		50	200	μA
I_{IB} Input bias current‡	$V_O = 2.5V$		200	400		200	400		200	400	μA
V_{OM} Peak output voltage swing‡	$R_L = 10k\Omega$		3.3	3.5		3.3	3.5		3.3	3.5	V
	$R_L = 10k\Omega$		$V_{CC+} - 1.7$			$V_{CC+} - 1.7$			$V_{CC+} - 1.7$		
A_{VD} Large-signal differential voltage amplification	$\Delta V_O = 1.6V$, $R_L = 2k\Omega$		20	200		20	200		20	200	V/mV
K_{SVR} Supply voltage rejection ratio ($\Delta V_{CC}/\Delta V_{IO}$)	$R_S = 50\Omega$, $V_C = \pm 3V$ to $\pm 15V$		75			75			75		dB
I_{CC} Supply current (per amplifier)	$V_O = 2.5V$, No load		1.5	2.5		1.5	2.5		1.5	2.5	mA
V_{O1}/V_{O2} Channel separation	$f = 1kHz$ to $20kHz$		120			120			120		dB

†All characteristics are specified under open-loop conditions.

‡Input bias currents of a FET-input operational amplifier are normal junction reverse currents, which are temperature sensitive. Pulse techniques must be used that will maintain the junction temperature as close to the ambient temperature as is possible.

§The output will swing essentially to ground provided that load, R_L , is connected from output to ground.

PARAMETER	TEST CONDITIONS			MIN	TYP	MAX	UNIT
SR Stew rate at unity gain	$V_I = \pm 10V$, See Figure 1	$C_L = 100pF$	$R_L = 2k\Omega$		0.6		V/ μs
t_r Rise time	$\Delta V_O = 50mV$, See Figure 1	$C_L = 100pF$	$R_L = 2k\Omega$		0.2		μs
t_f Fall time					0.2		μs
Overshoot factor					20%		
Crossover distortion	$V_{Ipp} = 30mV$	$V_{Opp} = 2V$	$f = 10kHz$		1%		
V_n Equivalent input Noise voltage	$R_S = 100\Omega$	$f = 1kHz$			34		nV/ \sqrt{Hz}

PARAMETER MEASUREMENT INFORMATION

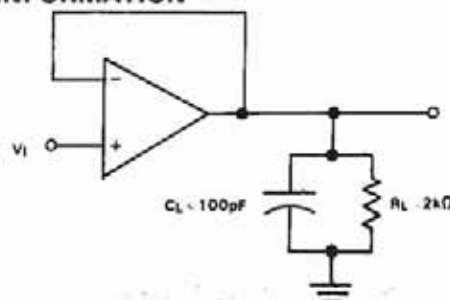

FIGURE 1-UNITY-GAIN AMPLIFIER

TL091, TL092, TL094 FET-INPUT OPERATIONAL AMPLIFIERS

electrical characteristics at specified free-air temperature, $V_{CC} \pm = \pm 15V$

PARAMETER	TEST CONDITIONS [†]	TL091M TL092M TL094M			TL091I TL092I TL094I			TL091C TL092C TL094C			UNIT	
		MIN	TYP	MAX	MIN	TYP	MAX	MIN	TYP	MAX		
V _{I0} Input offset voltage	T _A = 25°C, R _S = 50Ω		5	9		5	9		5	15	mV	
	T _A = full range, R _S = 50Ω			15			15			20		
°V _{I0} Temperature coefficient of input offset voltage	T _A = 25°C		10			10			10		V/°C	
I _{I0} Input offset current ⁵	T _A = 25°C		50	200		50	200		50	200	pA	
	T _A = full range			20			10			5	nA	
I _{IB} Input bias current ⁵	T _A = 25°C		200	400		200	400		200	400	pA	
	T _A = full range			50			20			10	nA	
V _{ICR} Common-mode input voltage range	T _A = 25°C	V _{CC-} to	V _{CC-} to		V _{CC-} to	V _{CC-} to		V _{CC-} to	V _{CC-} to		V	
		12	13		12	13		12	13			
V _{OM} Peak output voltage swing	R _L = 10kΩ, T _A = 25°C		-12	±13.5		±12	-13.5		-12	-13.5	V	
	R _L = 2kΩ, T _A = 25°C		±10	±13		±10	±13		-10	-13		
	R _L = 2kΩ, T _A = full range		±10			±10			-10			
A _{VD} Large-signal differential voltage amplification	R _L = 2kΩ, V _O ±10V	T _A = 25°C	50	200	20	200	20	200	20	200	V/mV	
		T _A = full range	25		15		15		15			
B _{OM} Maximum-output-swing bandwidth	V _{OPP} = 20V, A _{VD} = 1, THD < 5%	R _L = 2kΩ, T _A = 25°C		9		9			9		kHz	
B ₁ Unity-gain bandwidth	R _L = 10kΩ, T _A = 25°C, V _O = 50mV			1		1					MHz	
φ _m Phase margin	C _L = 200pF, R _L = 2kΩ, T _A = 25°C			60°		60°			60°			
r _i Input resistance	f = 20Hz, T _A = 25°C			10 ¹²		10 ¹²			10 ¹²		Ω	
r _o Output resistance	f = 20Hz, T _A = 25°C			75		75			75		Ω	
CMRR Common-mode rejection ratio	V _{IC} = V _{ICR} , T _A = 25°C, R _S = 50Ω		70	90	70	90	70	90	70	90	dB	
k _{SVR} Supply voltage rejection ratio (ΔV _{CC} / ΔV _{IO})	V _{CC} ± 3V to ±15V, R _S = 50Ω, T _A = 25°C		75	90	75	90	75	90	75	90	dB	
I _{OS} Short-circuit output current	T _A = 25°C		-10	-40	-84	-10	-40	-84	-10	-40	-84	mA
I _{CC} Total supply current per amplifier	No load, T _A = 25°C, V _O = 0V		1.5	2.5	1.5	2.5	1.5	2.5	1.5	2.5	mA	

[†]All characteristics are specified under open-loop conditions unless otherwise noted. Full range for T_A is -55°C for TL091M, -40°C to 85°C for TL091I, and 0°C to 70°C for TL091C.

[‡]The V_{ICR} limits are directly linked volt-for-volt to supply voltage, i.e., the positive limit is 3 volts less than V_{CC+}.

⁵Input bias currents of a FET-input operational amplifier are normal junction reverse currents, which are temperature sensitive. Pulse techniques must be used that will maintain the junction temperature as close to the ambient temperature as is possible.

TYPES TL091, TL092, TL094 JFET-INPUT OPERATIONAL AMPLIFIERS

TYPICAL CHARACTERISTICS

4

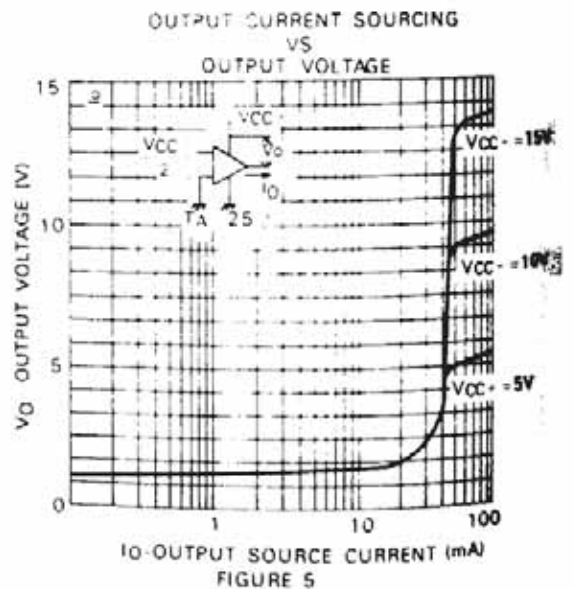
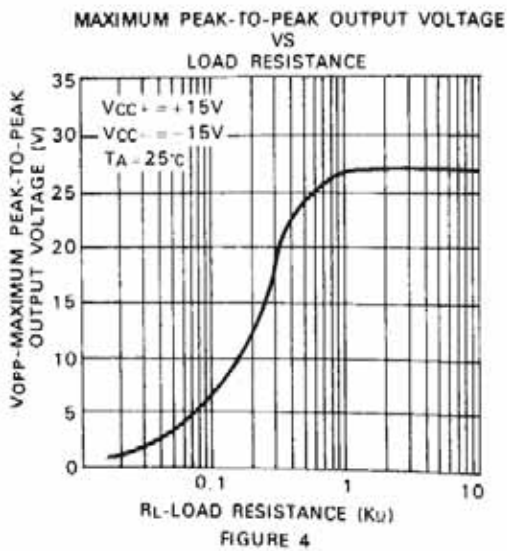
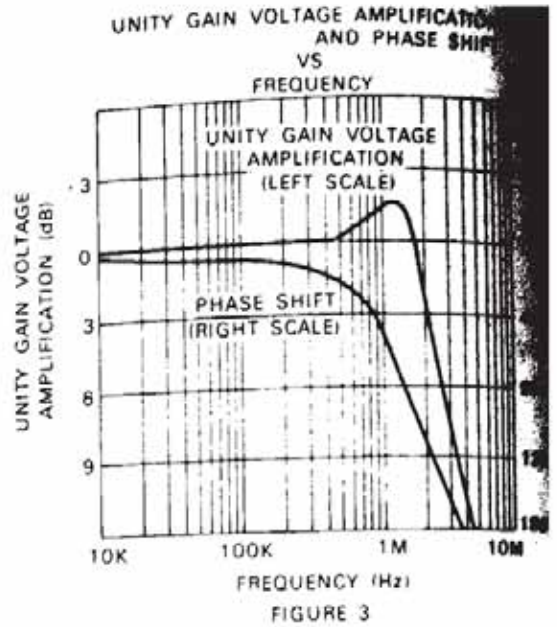
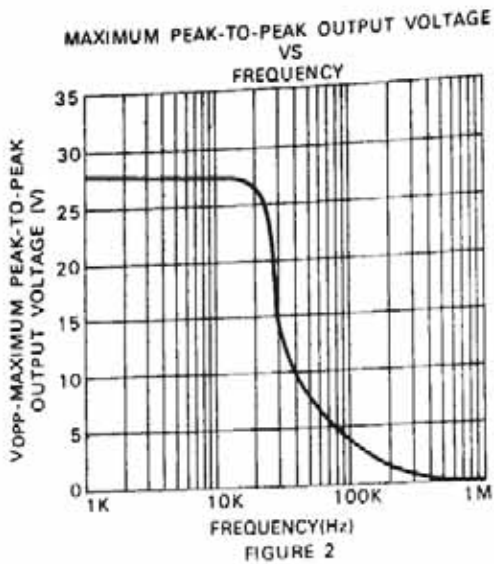

TYPES TL091, TL092, TL094 JFET-INPUT OPERATIONAL AMPLIFIERS

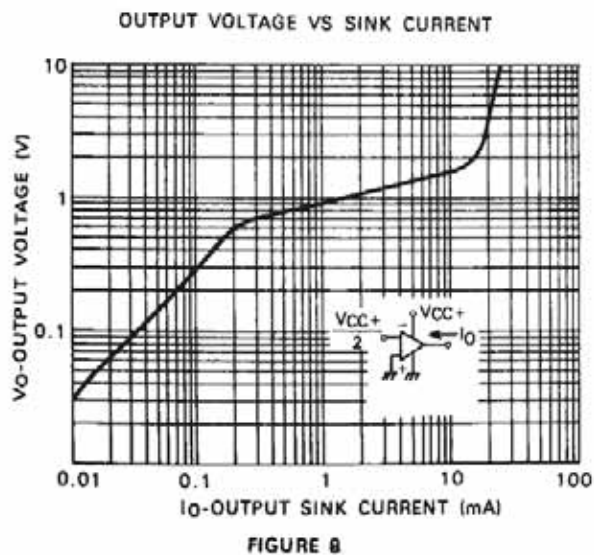
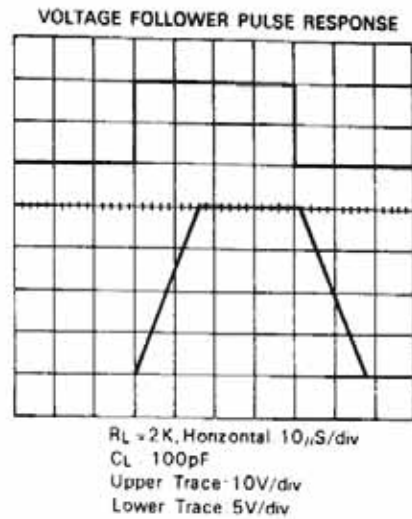
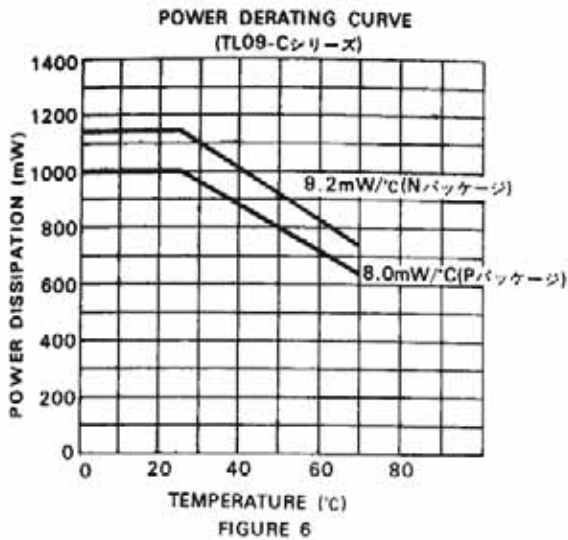

TYPES TL091, TL092, TL094 JFET-INPUT OPERATIONAL AMPLIFIERS

TYPICAL APPLICATION DATA

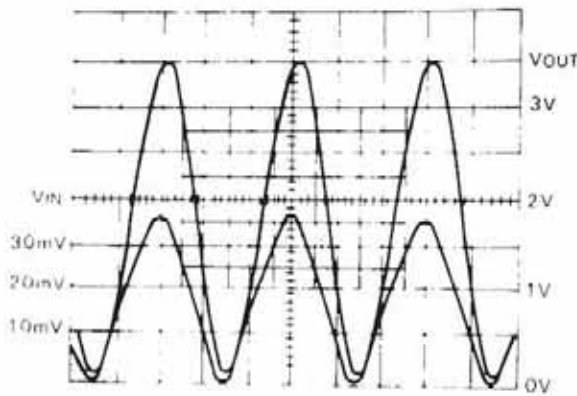
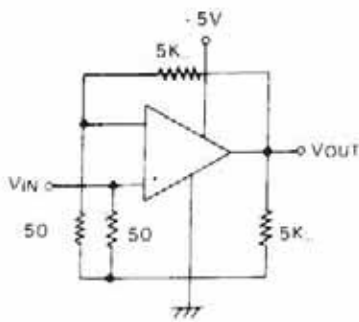

FIGURE 9 SINGLE SUPPLY NON-INVERTING AMP AND WAVE FORM

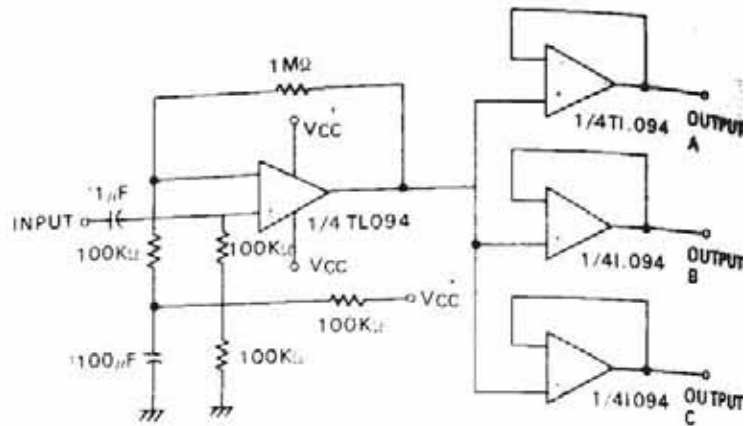

FIGURE 10-AUDIO DISTRIBUTION AMPLIFIER

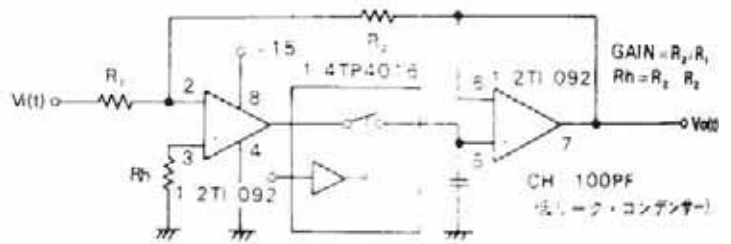

FIGURE 11-SINGLE SUPPLY SAMPLE AND HOLD CIRCUIT

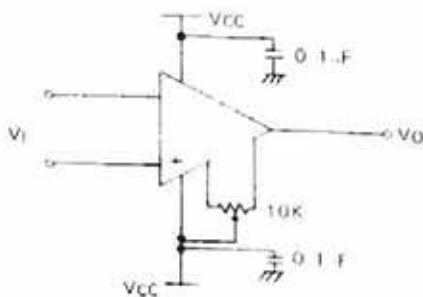

FIGURE 12 TL091 OFFSET ADJUSTMENT

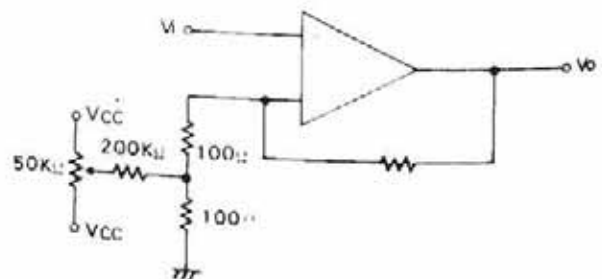

FIGURE 13-OFFSET ADJUSTMENT FOR NON-INVERTING AMP

**TYPES TL091, TL092, TL094
JFET-INPUT OPERATIONAL AMPLIFIERS**

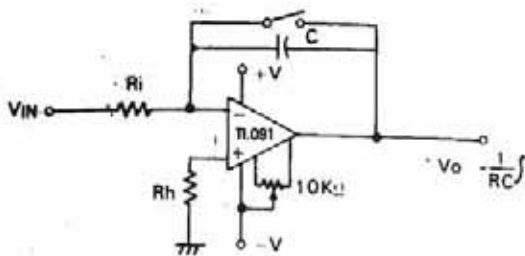

FIGURE 14-LONG TERM INTEGRATOR

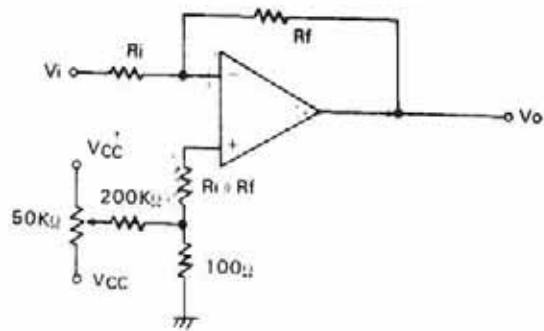

FIGURE 15-OFFSET ADJUSTMENT FOR INVERTING

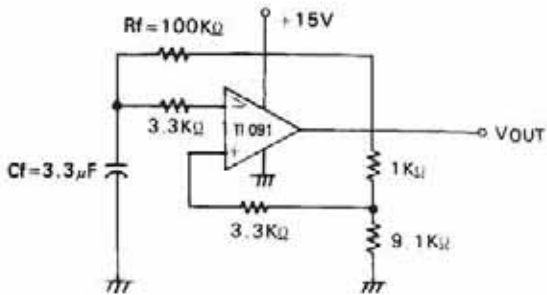

FIGURE 16-0 5Hz SQUARE-WAVE OSCILLATOR