



TPA12/ TPA12A Power Operational Amplifier



THALER CORPORATION • 2015 N. FORBES BOULEVARD • TUCSON, AZ. 85745 • (520) 882-4000

FEATURES

- HIGH OUTPUT CURRENT - $\pm 15A$ PEAK
- HIGH VOLTAGE RATING - $\pm 50V$
- LOW THERMAL RESISTANCE – 1.4 °C/W
- CURRENT FOLDOVER PROTECTION
- EXCELLENT LINEARITY - CLASS A/B OUTPUT

APPLICATIONS

- MOTOR, VALVE AND ACTUATOR CONTROL
- MAGNETIC DEFLECTION CIRCUITS UP TO $10A$
- POWER TRANSDUCERS UP TO 100 kHz
- AUDIO AMPLIFIERS UP TO $120W$ RMS

DESCRIPTION

The TPA12 and TPA12A are designed for high voltage and high current applications. They can deliver up to 600 Watts of power to a load. The safe operating area (SOA) at the output stage can be guaranteed for all operating conditions by properly selecting the external current limiting resistor.

The class A/B output stage delivers power with remarkably low distortion (see graph page 3). In order to maintain stable bias current and low distortion over the operating temperature range a resistor/thermistor network in the V_{BE} multiplier is used to closely match the V_{BE} of the output transistors.

EQUIVALENT SCHEMATIC

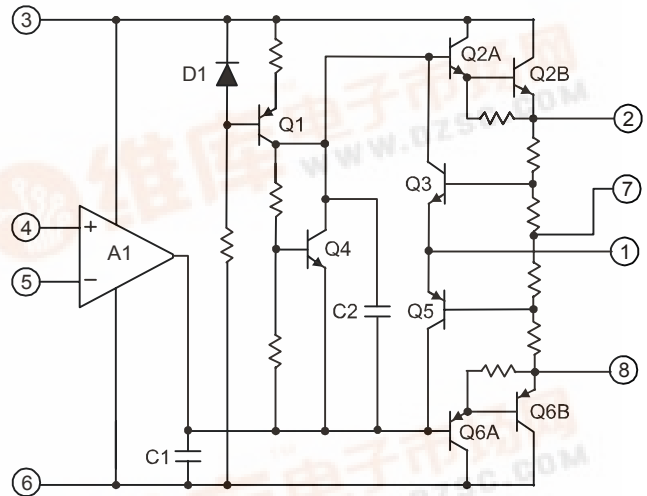

EXTERNAL CONNECTIONS AND PIN CONFIGURATIONS

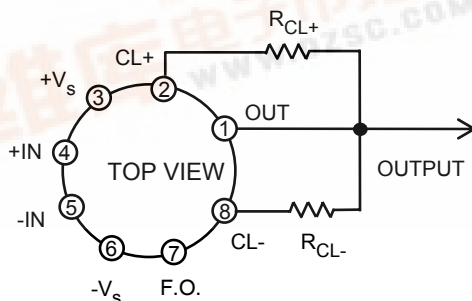

TPA12/TPA12A

ABSOLUTE MAXIMUM RATINGS

Supply Voltage	100V	Temperature, pin solder – 10s	300°C
Output Current, within SOA	15A	Temperature, junction ¹	200°C
Power Dissipation, internal	125W	Temperature range, storage	-65 to +150°C
Input Voltage, differential	$\pm V_S - 3V$	Operating temperature range, case	-55 to +125°C
Input Voltage, common mode	$\pm V_S$		

Electrical Specifications

TPA12

TPA12A

PARAMETER	CONDITIONS ^{2,5}	MIN	TYP	MAX	MIN	TYP	MAX	UNITS
INPUT								
Offset Voltage, initial	$T_c = 25^\circ\text{C}$		± 2	± 6		± 1	± 4	mV
Offset Voltage, vs. temp.	full temperature range		± 10	± 65		*	± 40	$\mu\text{V}/^\circ\text{C}$
Offset Voltage, vs. supply	$T_c = 25^\circ\text{C}$		± 30	± 200		*	*	$\mu\text{V}/\text{V}$
Offset Voltage, vs. power	$T_c = 25^\circ\text{C}$		± 20			*		$\mu\text{V}/\text{W}$
Bias Current, initial	$T_c = 25^\circ\text{C}$		± 12	± 30		10	20	nA
Bias Current, vs. temp.	full temperature range		± 50	± 500		*	*	$\text{pA}/^\circ\text{C}$
Bias Current, vs. supply	$T_c = 25^\circ\text{C}$		± 10			*		pA/V
Offset Current, initial	$T_c = 25^\circ\text{C}$		± 12	± 30		± 5	± 20	nA
Offset Current, vs. temp.	full temperature range		± 50			*		$\text{pA}/^\circ\text{C}$
Input Impedance, DC	$T_c = 25^\circ\text{C}$		200			*		M Ω
Input Capacitance	$T_c = 25^\circ\text{C}$		3			*		pF
Common Mode Volt. Range ³	full temperature range	$\pm V_S - 5$	$\pm V_S - 3$		*	*		V
Common Mode Rejection, DC	full temp. range $V_{CM} = \pm V_S - 5$	74	100		*	*		db
GAIN								
Open Loop Gain at 10Hz	$T_c = 25^\circ\text{C}$, 1k Ω load		110			*		db
Open Loop Gain at 10Hz	Full temp range, 8 Ω load	96	108		*	*		db
Gain Bandwidth Product (1MHz)	$T_c = 25^\circ\text{C}$, 8 Ω load		4			*		MHz
Power Bandwidth	$T_c = 25^\circ\text{C}$, 8 Ω load	13	20		*	*		kHz
Phase Margin $A_v = +4$	Full temp range, 8 Ω load		20			*		o
OUTPUT								
Voltage Swing ³	$T_c = 25^\circ\text{C}$, TPA12 = 10A, TPA12A = 15A	$\pm V_S - 6$			*			V
Voltage Swing ³	$T_c = 25^\circ\text{C}$, $I_o = 5\text{A}$	$\pm V_S - 5$			*			V
Voltage Swing ³	full temp range, $I_o = 80\text{mA}$	$\pm V_S - 5$			*			V
Current, peak	$T_c = 25^\circ\text{C}$	10			15			A
Settling Time to .1%, Slew Rate	$T_c = 25^\circ\text{C}$, 2V step $T_c = 25^\circ\text{C}$	2.5	2 4		*	*		μs V/ μs
Capacitive Load	full temp range, $A_v = 4$			1.5			*	nF
Capacitive Load	full temp range, $A_v > 10$			SOA			*	
POWER SUPPLY								
Voltage	full temp range	± 10	± 40	± 45	*	*	± 50	V
Current, quiescent	$T_c = 25^\circ\text{C}$		25	50		*	*	mA
THERMAL								
Resistance, AC junction to case ⁴	$T_c = -55$ to $+125^\circ\text{C}$, $F > 60\text{Hz}$		0.8	0.9		*	*	$^\circ\text{C}/\text{W}$
Resistance, DC junction to case	$T_c = -55$ to $+125^\circ\text{C}$		1.25	1.4		*	*	$^\circ\text{C}/\text{W}$
Resistance, junction to air	$T_c = -55$ to $+125^\circ\text{C}$		30			*		$^\circ\text{C}/\text{W}$
Temperature Range, case	Meets full range specifications	-25		+85	-55		+125	$^\circ\text{C}$

Notes: *Same as previous Model.

1. Long term operation at the maximum junction temperature will result in reduced product life. Derate internal power dissipation to achieve high MTTF.
2. The power supply voltage for all specifications is $\pm 40\text{V}$ unless otherwise noted as a test condition.
3. +Vs and -Vs denote the positive and negative supply rail respectively. Total Vs is measured from +Vs to -Vs.
4. Rating applies if the output current alternates between both output transistors at a rate faster than 60Hz.
5. Exceeding CMV range can cause the output to latch.

Caution: The internal substrate contains beryllia (BeO). Do not crush, break, machine or subject the substrate to temperatures in excess of 850C.

TYPICAL PERFORMANCE CURVES

POWER DERATING

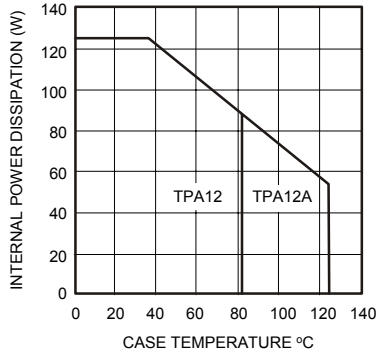

BIAS CURRENT

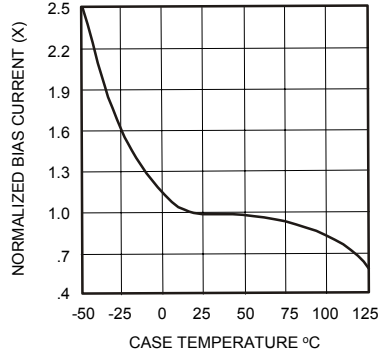

CURRENT LIMIT

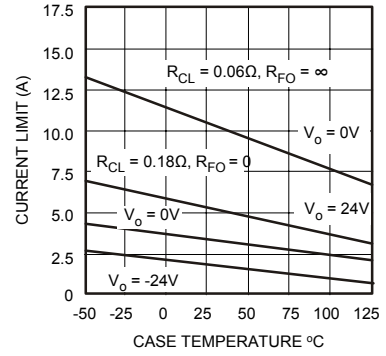

SMALL SIGNAL RESPONSE

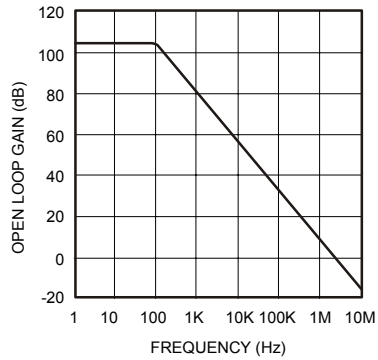

PHASE RESPONSE

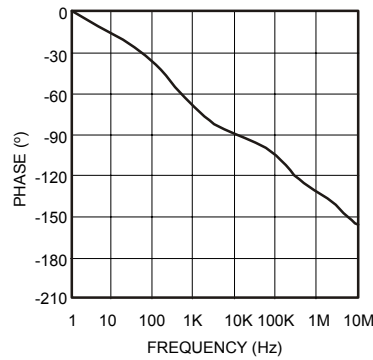

POWER RESPONSE

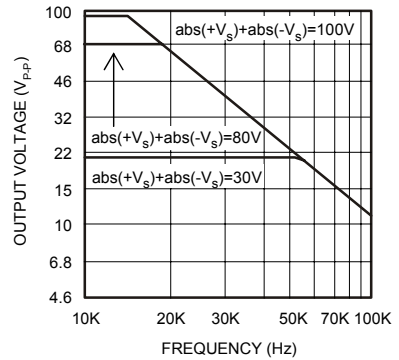

COMMON MODE REJECTION

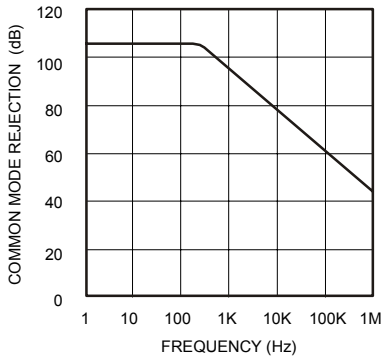

PULSE RESPONSE

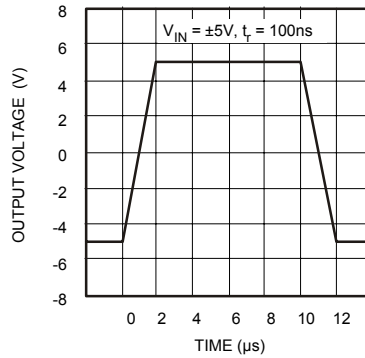

INPUT NOISE

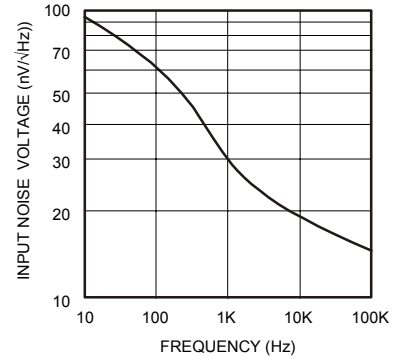

HARMONIC DISTORTION

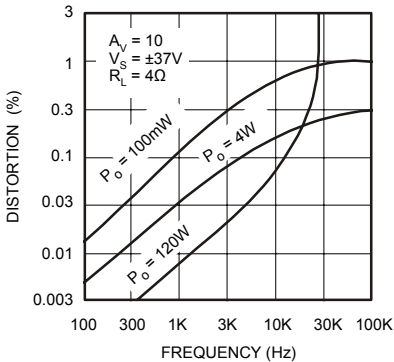

QUIESCENT CURRENT

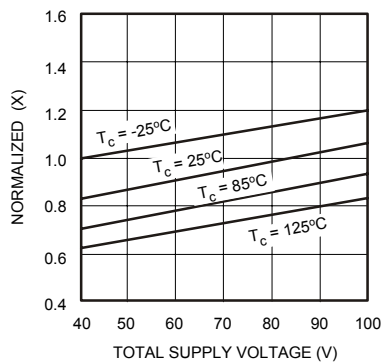

OUTPUT VOLTAGE SWING

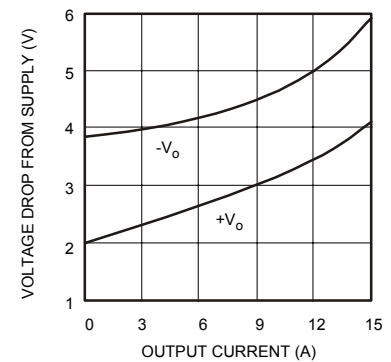

DISCUSSION OF PERFORMANCE

SAFE OPERATING AREA (SOA)

The output stage of most power amplifiers has three distinct limitations:

- 1) The current handling capability of the transistor geometry and the wire bonds.
- 2) The second breakdown effect which occurs whenever the simultaneous collector current and collector-emitter voltage exceeds specified limits.
- 3) The junction temperature of the output resistors.

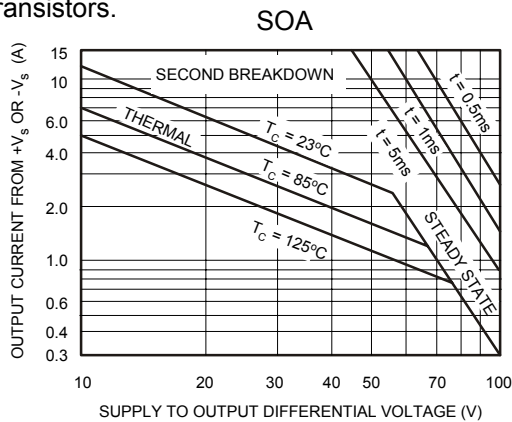

The SOA curves combine the effect of all limits for this Power Op Amp. For a given application, the direction and magnitude of the output current should be calculated or measured and checked against the SOA curves. This is simple for resistive loads but more complex for reactive and EMF generating loads. The following guidelines may save extensive analytical efforts.

1. Capacitive and dynamic* loads up to the following maximums are safe with the current limits set as specified.

±Vs	Capacitive Load		Inductive Load	
	I _{LIM} = 5A	I _{LIM} = 10A	I _{LIM} = 5A	I _{LIM} = 10A
50V	200µF	125µF	5mH	2.0mH
40V	500µF	350µF	15mH	3.0mH
35V	2.0mF	850µF	50mH	5.0mH
30V	7.0mF	2.5mF	150mH	10mH
25V	25mF	10mF	500mH	20mH
20V	60mF	20mF	1,000mH	30mH
15V	150mF	60mF	2,500mH	50mH

2. The amplifier can handle any EMF generating or reactive load and short circuits to the supply rail or common if the current limits are set as follows at T_c = 25°C.

* If the inductive load is driven near steady state conditions, allowing the output voltage to drop more than 8V below the supply rail with I_{LIM} = 15A or 25V below the supply rail with I_{LIM} = 5A while the amplifier is current limiting, the inductor must be capacitively coupled or the current limit must be lowered to meet SOA criteria.

±Vs	Short to ±Vs C,L or EMF Load	Short to Common
50V	0.30A	2.4A
40V	0.58A	2.9A
35V	0.87A	3.7A
30V	1.50A	4.1A
25V	2.40A	4.9A
20V	2.90A	6.3A
15V	4.20A	8.0A

These simplified limits may be exceeded with further analysis using the operating conditions for a specific application.

CURRENT LIMIT

For fixed current limit, leave pin 7 open and use the equations in 1 and 2.

$$R_{CL} = 0.65/I_{CL} \quad (1)$$

$$I_{CL} = 0.65/R_{CL} \quad (2)$$

Where:

I_{CL} is the current limit in amperes.

R_{CL} is the current limit resistor in ohms.

For certain applications the foldover current limit adds a slope to the current limit which allows more power to be delivered to the load without violating the SOA. For maximum foldover slope, ground pin 7 and use equations 3 and 4.

$$I_{CL} = (0.65 + (V_o * 0.014)) / R_{CL} \quad (3)$$

$$R_{CL} = (0.65 + (V_o * 0.014)) / I_{CL} \quad (4)$$

Where V_o is the output voltage in volts.

Most designers start with either equation 1 to set R_{CL} for the desired output current at 0V out or with equation 4 set to R_{CL} at the maximum output voltage. Equation 3 should then be used to plot the resulting foldover limits on the SOA graph. If equation 3 results in a negative current limit, foldover slope must be reduced. This can happen when the output voltage is the opposite polarity of the supply conducting the current.

In applications where a reduced foldover slope is desired, this can be achieved by adding a resistor (R_{FO}) between pin 7 and ground. Use equations 5 and 6 with this new resistor in the circuit.

$$I_{CL} = ((0.65 + (V_o * 0.014)) / (10.14 + R_{FO})) / R_{CL} \quad (5)$$

$$R_{CL} = ((0.65 + (V_o * 0.014)) / (10.14 + R_{FO})) / I_{CL} \quad (6)$$

Where R_{FO} is in K ohms.

MECHANICAL

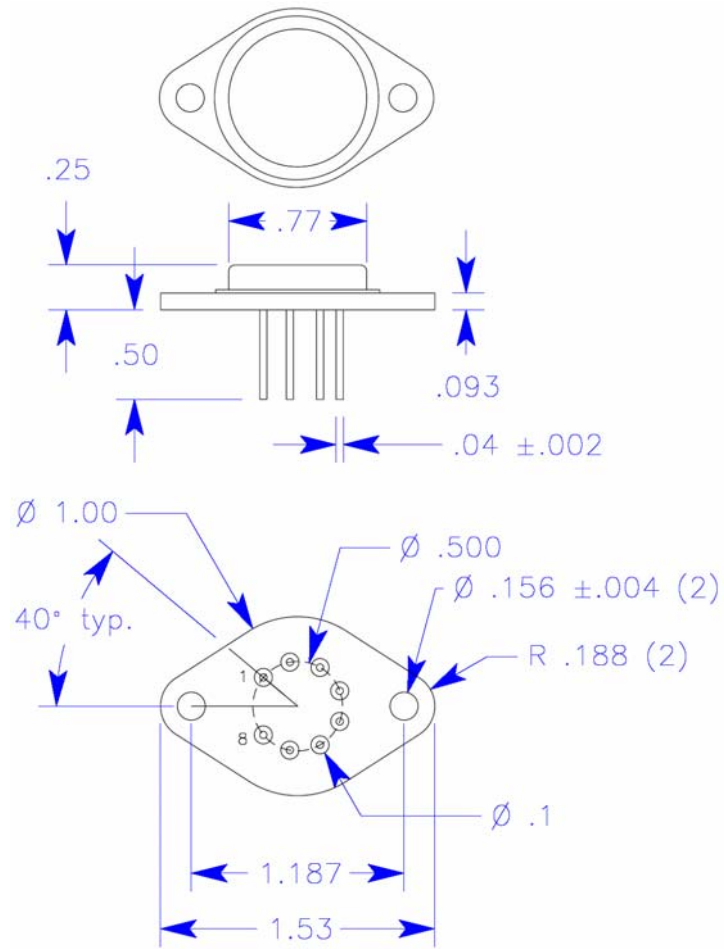

TO3-8 Package