

2.7-W CONSTANT OUTPUT POWER CLASS-D AUDIO AMPLIFIER WITH INTEGRATED BOOST CONVERTER

FEATURES

- High Efficiency Integrated Boost Converter (Over 90% Efficiency)
- 2.2-W into an 8-Ω Load from a 3.6-V Supply
- 2.7-W into an 4-Ω Load from a 3.6-V Supply
- Operates from 1.8 V to 5.5 V
- Efficient Class-D Prolongs Battery Life
- Independent Shutdown for Boost Converter and Class-D Amplifier
- Differential Inputs Reduce RF Common Noise
- Built-in INPUT Low Pass Filter Decreases RF and Out of Band Noise Sensitivity
- Synchronized Boost and Class-D Eliminates Beat Frequencies
- Thermal and Short-Circuit Protection
- Available in 2.275 mm x 2.275 mm 16-ball WCSP and 4 mm x 4 mm 20-Lead QFN Packages
- 3 Selectable Gain Settings of 2 V/V, 6 V/V, and 10 V/V

APPLICATIONS

- Cell Phones
- PDA
- GPS
- Portable Electronics

DESCRIPTION

The TPA2013D1 is a high efficiency Class-D audio power amplifier with an integrated boost converter. It drives up to 2.7 W (10% THD+N) into a 4 Ω speaker. With 85% typical efficiency, the TPA2013D1 helps extend battery life when playing audio.

The built-in boost converter generates the voltage rail for the Class-D amplifier. This provides a louder audio output than a stand-alone amplifier connected directly to the battery. It also maintains a consistent loudness, regardless of battery voltage. Additionally, the boost converter can be used to supply external devices.

The TPA2013D1 has an integrated low pass filter to improve RF rejection and reduce out-of-band noise, increasing the signal to noise ratio (SNR). A built-in PLL synchronizes the boost converter and Class-D switching frequencies, thus eliminating beat frequencies and improving audio quality. All outputs are fully protected against shorts to ground, power supply, and output-to-output shorts.

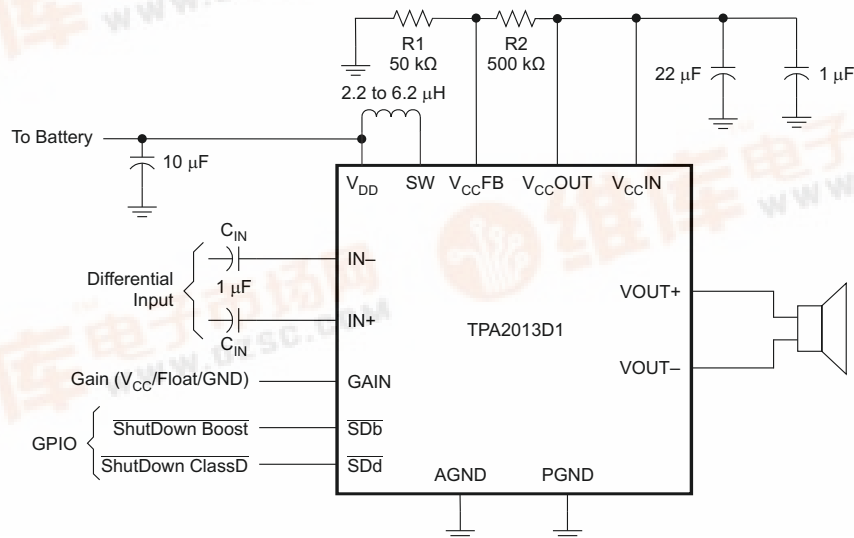

Please be aware that an important notice concerning availability, standard warranty, and use in critical applications of Texas Instruments semiconductor products and disclaimers thereto appears at the end of this data sheet.



These devices have limited built-in ESD protection. The leads should be shorted together or the device placed in conductive foam during storage or handling to prevent electrostatic damage to the MOS gates.

DEVICE INFORMATION

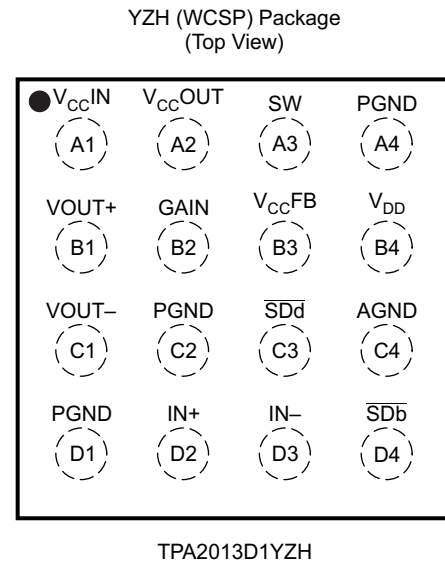
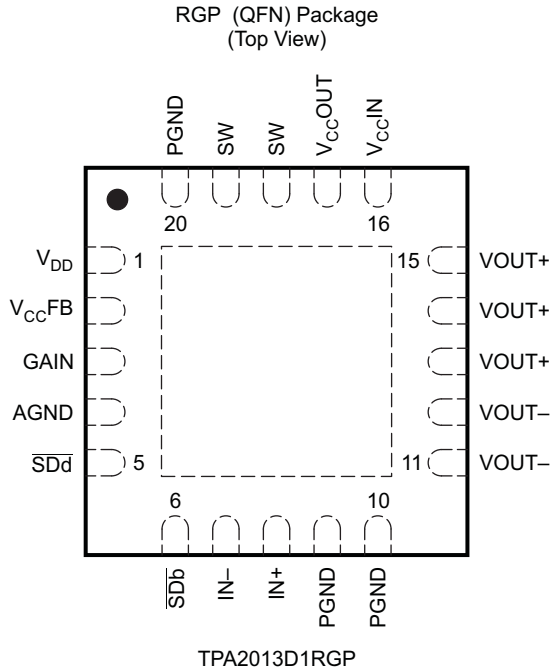

BOOST CONVERTER TERMINAL FUNCTIONS

NAME	TERMINAL		I/O	DESCRIPTION
	QFN	WCSP		
IN+	8	D2	I	Positive audio input
IN-	7	D3	I	Negative audio input
VOUT+	13, 14, 15	B1	O	Positive audio output
VOUT-	11, 12	C1	O	Negative audio output
SDb	6	D4	I	Shutdown terminal for the Boost Converter
SDd	5	C3	I	Shutdown terminal for the Class D Amplifier
SW	18, 19	A3	-	Boost and rectifying switch input
VCCOUT	17	A2	-	Boost converter output - connect to VCCIN
GAIN	3	B2	I	Gain selection pin
VCCIN	16	A1	-	Class-D audio power amplifier voltage supply - connect to VCCOUT
VCCFB	2	B3	I	Voltage feedback
VDD	1	B4	-	Supply voltage
AGND	4	C4	-	Analog ground - connect all GND pins together
PGND	9, 10, 20	D1, C2, A4	-	Power ground - connect all GND pins together
Thermal Pad	Die Pad	N/A	P	Solder the thermal pad on the bottom of the QFN package to the GND plane of the PCB. It is required for mechanical stability and will enhance thermal performance.

Functional Block Diagram

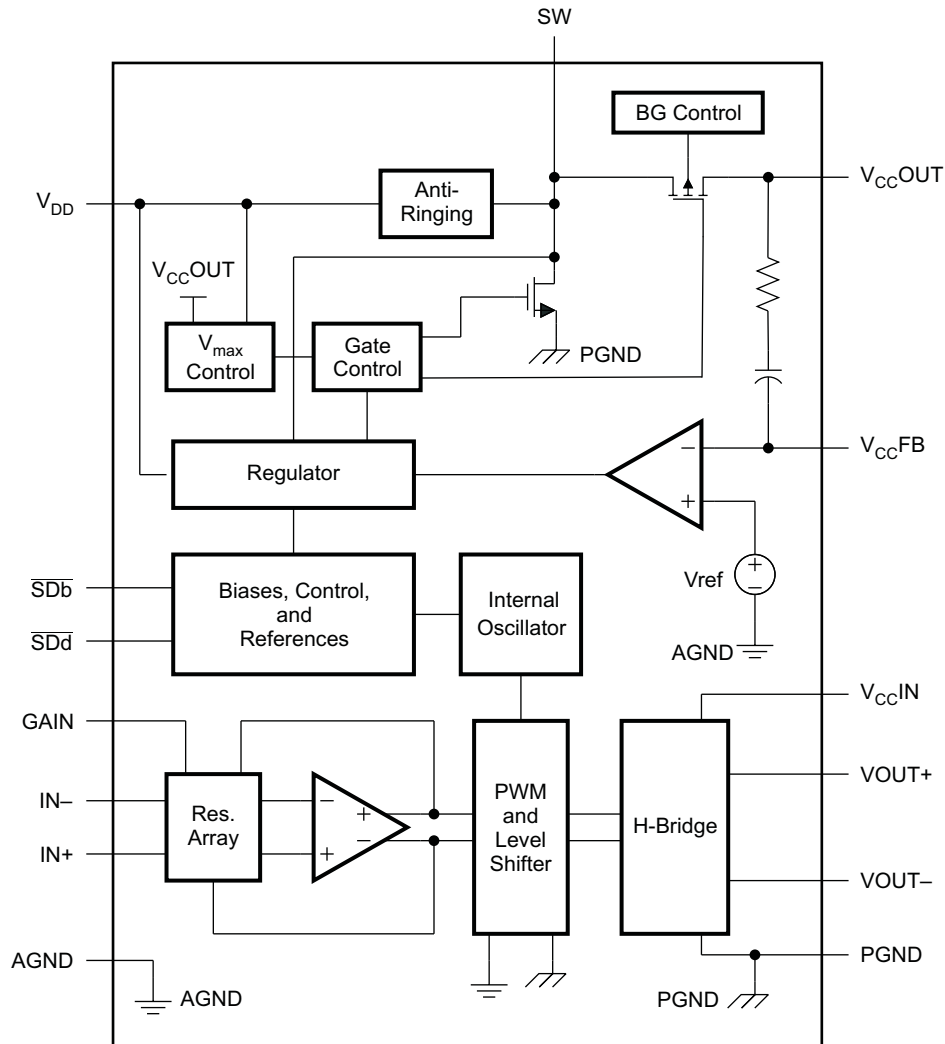

Table 1. BOOST CONVERTER MODE CONDITION

CASE	OUTPUT CURRENT	MODE OF OPERATION
$V_{DD} < V_{CC}$	Low	Continuous (fixed frequency)
$V_{DD} < V_{CC}$	High	Continuous (fixed frequency)
$V_{DD} \geq V_{CC}$	Low	Discontinuous (variable frequency)
$V_{DD} \geq V_{CC}$	High	Discontinuous (variable frequency)

Table 2. DEVICE CONFIGURATION

\overline{SDb}	\overline{SDd}	Boost Converter	Class D Amplifier	Comments
low	low	OFF	OFF	Device is in shutdown mode $I_q \leq 1 \mu A$
low	high	OFF	ON	Boost converter is off. Class-D Audio Power Amplifier (APA) can be driven by an external pass transistor connected to the battery.
high	low	ON	OFF	Class-D APA is off. Boost Converter is on and can be used to drive an external device.
high	high	ON	ON	Boost converter and Class-D APA are on. Normal operation. Boost converter can be used to drive an external device in parallel to the Class-D APA within the limits of the boost converter output current.

ABSOLUTE MAXIMUM RATINGS

over operating free-air temperature range (unless otherwise noted) ⁽¹⁾

		VALUE	UNIT
V _{DD}	Supply voltage	–0.3 to 6	V
V _I	Input voltage, V _i : \overline{SDb} , \overline{SDd} , IN+, IN–, V _{CC} FB	–0.3 to V _{DD} + 0.3	V
	Continuous total power dissipation	See Dissipation Rating Table	
T _A	Operating free-air temperature range	–40 to 85	°C
T _J	Operating junction temperature range	–40 to 150	°C
T _{stg}	Storage temperature range	–65 to 150	°C

(1) Stresses beyond those listed under *absolute maximum ratings* may cause permanent damage to the device. These are stress ratings only, and functional operations of the device at these or any other conditions beyond those indicated under *recommended operating conditions* is not implied. Exposure to absolute-maximum-rated conditions for extended periods may affect device reliability.

DISSIPATION RATINGS

PACKAGE	T _A ≤ 25°C	DERATING FACTOR ⁽¹⁾	T _A = 70°C	T _A = 85°C
16 ball WCSP	1.5 W	12.4 mW/°C	1 W	0.8 W
20 pin QFN	2.5 W	20.1 mW/°C	1.6 W	1.3 W

(1) Derating factor measured with JEDEC High K board.

AVAILABLE OPTIONS

T _A	PACKAGED DEVICES ⁽¹⁾	PART NUMBER	SYMBOL
–40°C TO 85°C	16-ball, 2.275 mm × 2.275 mm WCSP (± 0.05mm tolerance)	TPA2013D1YZH	BTH
	20-pin, 4 mm × 4 mm QFN	TPA2013D1RGP ⁽²⁾	BTI

- (1) For the most current package and ordering information, see the Package Option Addendum at the end of this document, or see the TI website at www.ti.com.
- (2) The RGP package is only available taped and reeled. To order, add suffix *R* to the end of the part number for a reel of 3000 (e.g., TPA2013D1RGPR).

RECOMMENDED OPERATING CONDITIONS

		MIN	MAX	UNIT
V _{DD}	Supply voltage	1.8	5.5	V
V _{IH}	High-level input voltage	\overline{SDb} , \overline{SDd}	1.3	V
V _{IL}	Low-level input voltage	\overline{SDb} , \overline{SDd}	0.35	V
I _{IH}	High-level input current	$\overline{SDb} = \overline{SDd} = 5.8$ V, V _{DD} = 5.5 V, V _{CC} = 5.5 V	1	μA
I _{IL}	Low-level input current	$\overline{SDb} = \overline{SDd} = -0.3$ V, V _{DD} = 5.5 V, V _{CC} = 5.5 V	20	μA
T _A	Operating free-air temperature	–40	85	°C

DC CHARACTERISTICS

T_A = 25°C (unless otherwise noted)

PARAMETER		TEST CONDITIONS	MIN	TYP	MAX	UNIT
V _{CC}	Class-D audio power amplifier voltage supply range, V _{CCIN}		3		5.5	V
I _{SD}	Shutdown quiescent current	$\overline{SDd} = \overline{SDb} = 0\text{ V}$, V _{DD} = 1.8 V, R _L = 8 Ω		0.04	1.5	μA
		$\overline{SDd} = \overline{SDb} = 0\text{ V}$, V _{DD} = 3.6 V, R _L = 8 Ω		0.04	1.5	
		$\overline{SDd} = \overline{SDb} = 0\text{ V}$, V _{DD} = 4.5 V, R _L = 8 Ω		0.02	1.5	
		$\overline{SDd} = \overline{SDb} = 0.35\text{ V}$, V _{DD} = 1.8 V, R _L = 8 Ω		0.03	1.5	
		$\overline{SDd} = \overline{SDb} = 0.35\text{ V}$, V _{DD} = 3.6 V, R _L = 8 Ω		0.03	1.5	
		$\overline{SDd} = \overline{SDb} = 0.35\text{ V}$, V _{DD} = 4.5 V, R _L = 8 Ω		0.02	1.5	
I _{DD}	Boost converter quiescent current	$\overline{SDd} = 0\text{ V}$, $\overline{SDb} = 1.3\text{ V}$, V _{DD} = 3.6 V, V _{CC} = 5.5 V, No Load, No Filter		1.3		mA
I _{CC}	Class D amplifier quiescent current	V _{DD} = 3.6, V _{CC} = 5.5 V, No Load, No Filter		4.3	6	mA
		V _{DD} = 4.5, V _{CC} = 5.5 V, No Load, No Filter		3.6	6	
I _{DD}	Boost converter and audio power amplifier quiescent current, Class D ⁽¹⁾	$\overline{SDd} = \overline{SDb} = 1.3\text{V}$, V _{DD} = 3.6, V _{CC} = 5.5 V, No Load, No Filter		16.5	23	mA
		$\overline{SDd} = \overline{SDb} = 1.3\text{V}$, V _{DD} = 4.5, V _{CC} = 5.5 V, No Load, No Filter		11	18.5	
f	Boost converter switching frequency		500	600	700	kHz
	Class D switching frequency		250	300	350	
UVLO	Under voltage lockout				1.7	V
GAIN	Gain input low level	Gain = 2 V/V (6dB)		0	0.35	V
	Gain input mid level	Gain = 6 V/V (15.5 dB) (floating input)	0.7	0.8	1	V
	Gain input high level	Gain = 10 V/V (20 dB)	1.35			V
POR _D	Class D Power on reset ON threshold			2.8		V

- (1) I_{DD} is calculated using $I_{DD} = (I_{CC} \times V_{CC}) / (V_{DD} \times \eta)$, where I_{CC} is the class D amplifier quiescent current; η = 40%, which is the boost converter efficiency when class D amplifier has no load. To achieve the minimal 40% η, it is recommended to use the suggested inductors in table 4 and to follow the layout guidelines.

BOOST CONVERTER DC CHARACTERISTICS $T_A = 25^\circ\text{C}$ (unless otherwise noted)

PARAMETER		TEST CONDITIONS	MIN	TYP	MAX	UNIT
V_{CC}	Output voltage range		3.0		5.5	V
V_{FB}	Feedback voltage		490	500	510	mV
I_{OL}	Output current limit, Boost_max		1300	1500	1700	mA
R_{ON_PB}	PMOS switch resistance			220		m Ω
R_{ON_NB}	NMOS resistance			170		m Ω
	Line regulation	No Load, $1.8\text{ V} < V_{DD} < 5.2\text{ V}$, $V_{CC} = 5.5\text{ V}$		3		mV/V
	Load regulation	$V_{DD} = 3.6\text{ V}$, $0 < I_L < 500\text{ mA}$, $V_{CC} = 5.5\text{ V}$		30		mV/A
I_L	Start up current limit, Boost			$0.4 \times I_{Boost}$		mA

CLASS D AMPLIFIER DC CHARACTERISTICS $T_A = 25^\circ\text{C}$ (unless otherwise noted)

PARAMETER		TEST CONDITIONS	MIN	TYP	MAX	UNIT
CMR	Input common mode range	$V_{in} = \pm 100\text{ mV}$, $V_{DD} = 1.8\text{ V}$, $V_{CC} = 3\text{ V}$, $R_L = 8\ \Omega$	0.5		2.2	V
		$V_{in} = \pm 100\text{ mV}$, $V_{DD} = 2.5\text{ V}$, $V_{CC} = 3.6\text{ V}$, $R_L = 8\ \Omega$	0.5		2.8	
		$V_{in} = \pm 100\text{ mV}$, $V_{DD} = 3.6\text{ V}$, $V_{CC} = 5.5\text{ V}$, $R_L = 8\ \Omega$	0.5		4.7	
CMRR	Input common mode rejection	$R_L = 8\ \Omega$, $V_{icm} = 0.5$ and $V_{icm} = V_{CC} - 0.8$, differential inputs shorted		-75		dB
V_{OO}	Output offset voltage Class-D	$V_{CC} = 3.6\text{ V}$, $A_v = 2\text{ V/V}$, $IN+ = IN- = V_{ref}$, $R_L = 8\ \Omega$		1	6	mV
		$V_{CC} = 3.6\text{ V}$, $A_v = 6\text{ V/V}$, $IN+ = IN- = V_{ref}$, $R_L = 8\ \Omega$		1	6	
		$V_{CC} = 3.6\text{ V}$, $A_v = 10\text{ V/V}$, $IN+ = IN- = V_{ref}$, $R_L = 8\ \Omega$		1	6	
		$V_{CC} = 5.5\text{ V}$, $A_v = 2\text{ V/V}$, $IN+ = IN- = V_{ref}$, $R_L = 8\ \Omega$		1	6	
R_{in}	Input Impedance	Gain = 2 V/V (6 dB)		32		k Ω
		Gain = 6 V/V (15.5 dB)		15		
		Gain = 10 V/V (20 dB)		9.5		
$R_{DS(on)}$	OUTP High-side FET On-state series resistance	$I_{OUTx} = -300\text{ mA}$; $V_{CC} = 3.6\text{ V}$		0.36		Ω
	OUTP Low-side FET On-state series resistance			0.36		
$R_{DS(on)}$	OUTN High-side FET On-state series resistance			0.36		
	OUTN Low-side FET On-state series resistance			0.36		
A_v	Low Gain	GAIN $\leq 0.35\text{ V}$	1.8	2	2.2	V/V
	Mid Gain	GAIN = 0.8 V	5.7	6	6.3	V/V
	High Gain	GAIN $\geq 1.35\text{ V}$	9.5	10	10.5	V/V

AC CHARACTERISTICS $T_A = 25^\circ\text{C}$, $V_{DD} = 3.6\text{ V}$, $R_L = 8\ \Omega$, $L = 4.7\ \mu\text{H}$ (unless otherwise noted)

PARAMETER		TEST CONDITIONS	MIN	TYP	MAX	UNIT
t_{START}	Start up time	$1.8\text{ V} \leq V_{DD} \leq 5.5\text{ V}$, $C_{IN} \leq 1\ \mu\text{F}$		7.5		ms
η	Efficiency	THD+N = 1%, $V_{CC} = 5.5\text{ V}$, $V_{DD} = 3.6\text{ V}$, $R_L = 8\ \Omega$, $P_{out} = 1.7\text{ W}$, $C_{boost} = 47\ \mu\text{F}$		85%		
		THD+N = 1%, $V_{CC} = 5.5\text{ V}$, $V_{DD} = 4.2\text{ V}$, $R_L = 8\ \Omega$, $P_{out} = 1.7\text{ W}$		87.5%		
	Thermal Shutdown	Threshold		150		$^\circ\text{C}$

CLASS D AMPLIFIER AC CHARACTERISTICS

$T_A = 25^\circ\text{C}$, $V_{DD} = 3.6\text{V}$, $R_L = 8\ \Omega$, $L = 4.7\ \mu\text{H}$ (unless otherwise noted)

PARAMETER		TEST CONDITIONS	MIN	TYP	MAX	UNIT
KSVR Class-D	Output referred power supply rejection ratio	$V_{DD} = 3.6\ \text{V}$, $V_{CC} = 5.5\text{V}$, 200 mV _{PP} ripple, $f = 217\ \text{Hz}$		-95		dB
THD+N Class-D	Total harmonic distortion + noise	$f = 1\ \text{kHz}$, $P_o = 1.7\ \text{W}$, $V_{CC} = 5.5\ \text{V}$		1%		
		$f = 1\ \text{kHz}$, $P_o = 1.2\ \text{W}$, $V_{CC} = 4.5\ \text{V}$		1%		
		$f = 1\ \text{kHz}$, $P_o = 2.2\ \text{W}$, $V_{CC} = 5.5\ \text{V}$		10%		
		$f = 1\ \text{kHz}$, $P_o = 1\ \text{W}$, $V_{CC} = 5.5\ \text{V}$		0.1%		
Vn Class-D	Output integrated noise floor	$A_v = 6\ \text{dB}$ (2V/V)		31		μVrms
	Output integrated noise floor A-weighted	$A_v = 6\ \text{dB}$ (2V/V)		23		
P _O	Maximum output power	THD+N = 10%, $V_{CC} = 5.5\text{V}$, $V_{DD} = 3.6\ \text{V}$, $R_L = 8\ \Omega$		2.2		W
		THD+N = 1%, $V_{CC} = 5.5\text{V}$, $V_{DD} = 3.6\ \text{V}$, $R_L = 8\ \Omega$		1.7		
		THD+N = 1%, $V_{CC} = 4.5\text{V}$, $V_{DD} = 3.6\ \text{V}$, $R_L = 8\ \Omega$		1.2		
		THD+N = 10%, $V_{CC} = 5.5\text{V}$, $V_{DD} = 3.6\ \text{V}$, $R_L = 4\ \Omega$		2.7		
		THD+N = 1%, $V_{CC} = 5.5\text{V}$, $V_{DD} = 3.6\ \text{V}$, $R_L = 4\ \Omega$		2.2		
		THD+N = 1%, $V_{CC} = 4.5\text{V}$, $V_{DD} = 3.6\ \text{V}$, $R_L = 4\ \Omega$		1.9		

TEST SET-UP FOR GRAPHS

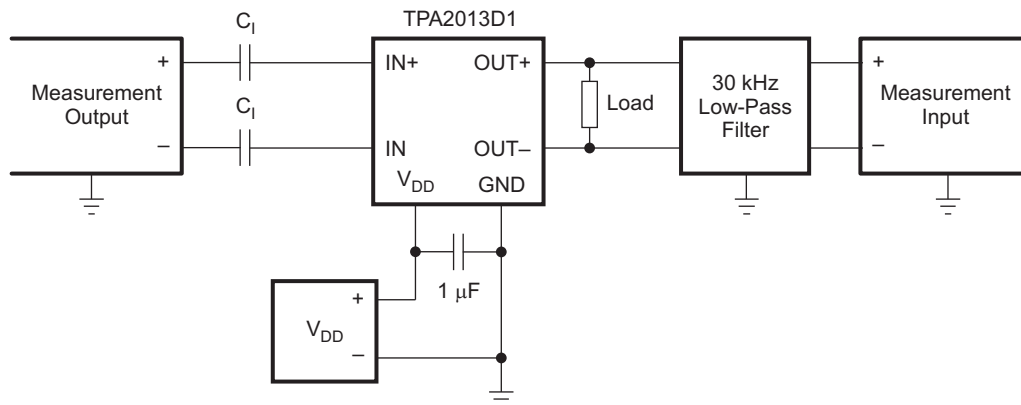

- (1) C_1 was shorted for any common-mode input voltage measurement. All other measurements were taken with a $1\text{-}\mu\text{F}$ C_1 (unless otherwise noted).
- (2) A $33\text{-}\mu\text{H}$ inductor was placed in series with the load resistor to emulate a small speaker for efficiency measurements.
- (3) The 30-kHz low-pass filter is required, even if the analyzer has an internal low-pass filter. An RC low-pass filter ($100\ \Omega$, 47-nF) is used on each output for the data sheet graphs.
- (4) $L = 4.7\ \mu\text{H}$ is used for the boost converter unless otherwise noted.

TYPICAL CHARACTERISTICS

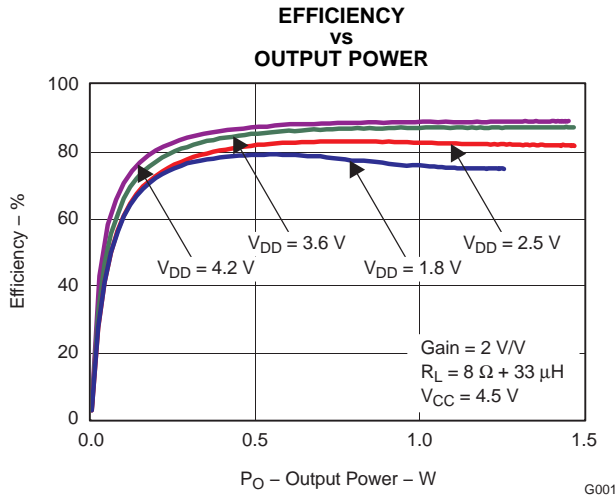

Figure 1.

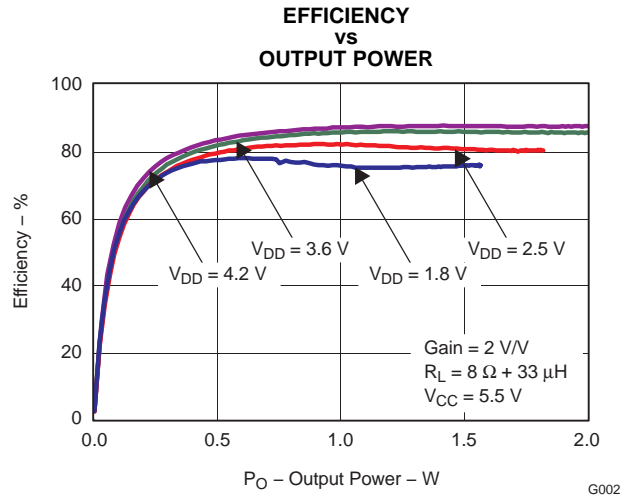

Figure 2.

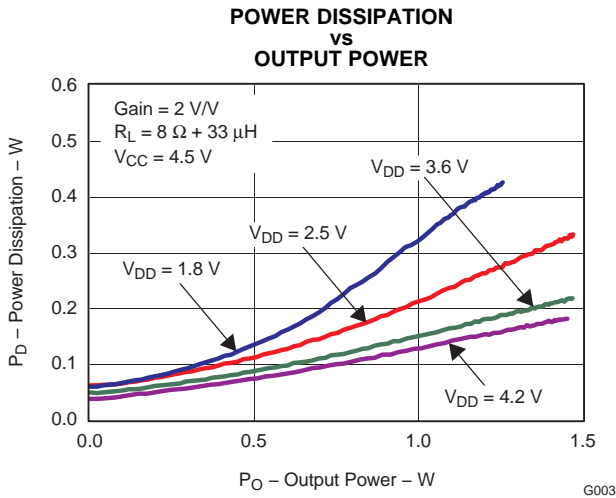

Figure 3.

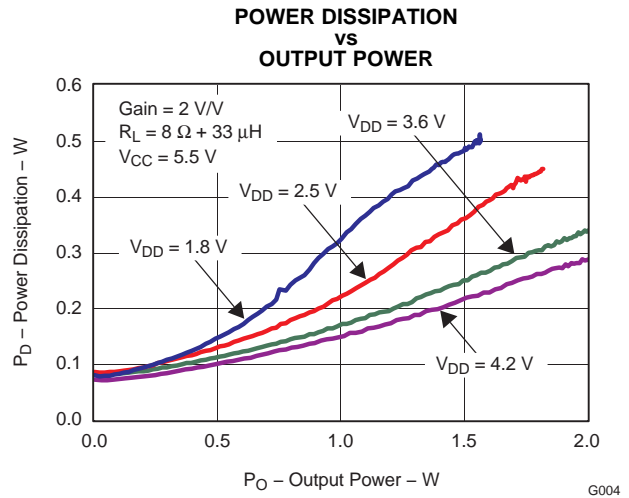

Figure 4.

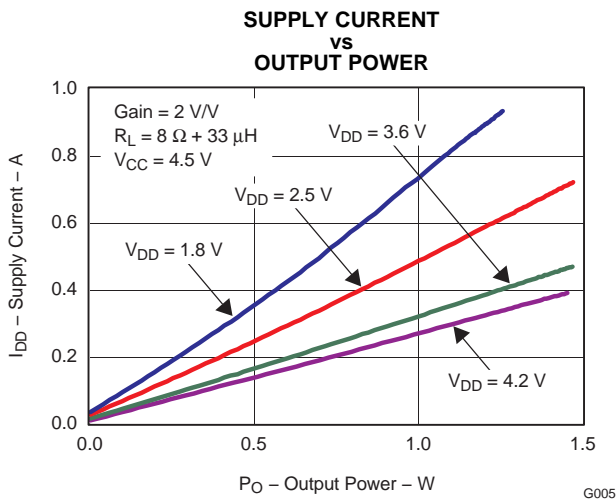

Figure 5.

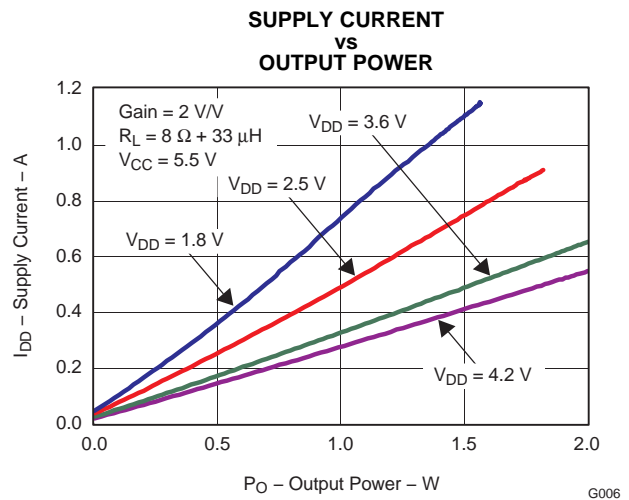

Figure 6.

TYPICAL CHARACTERISTICS (continued)

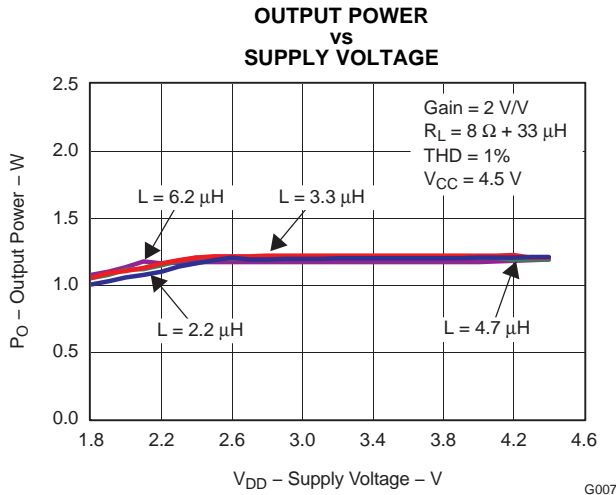

Figure 7.

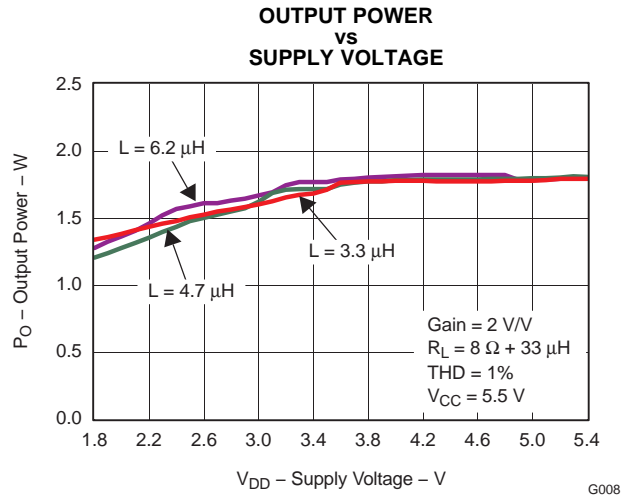

Figure 8.

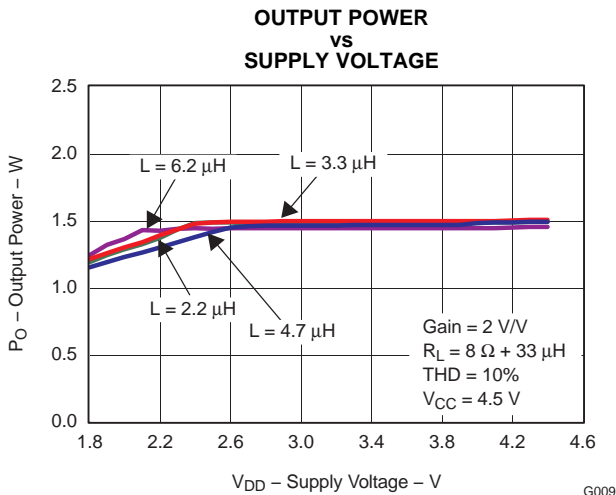

Figure 9.

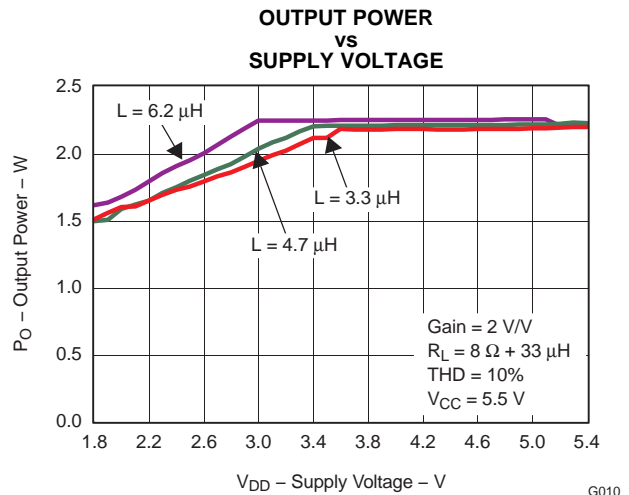

Figure 10.

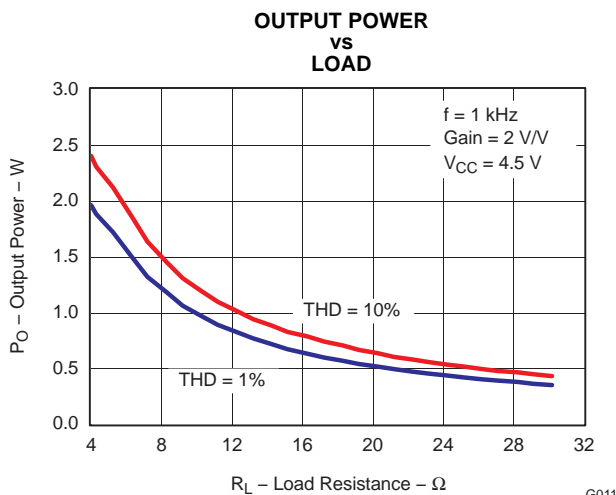

Figure 11.

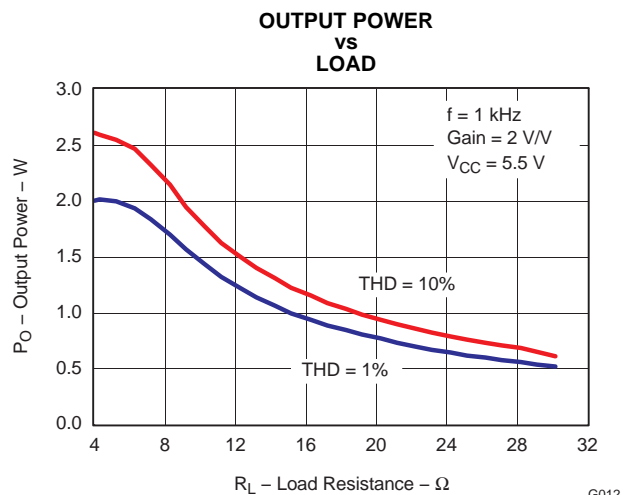

Figure 12.

TYPICAL CHARACTERISTICS (continued)

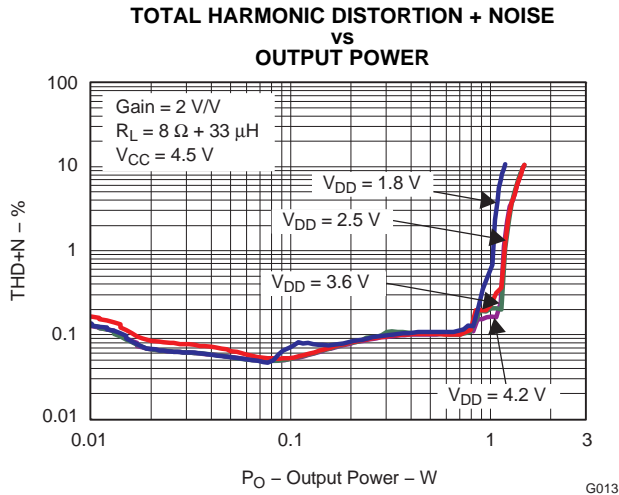

Figure 13.

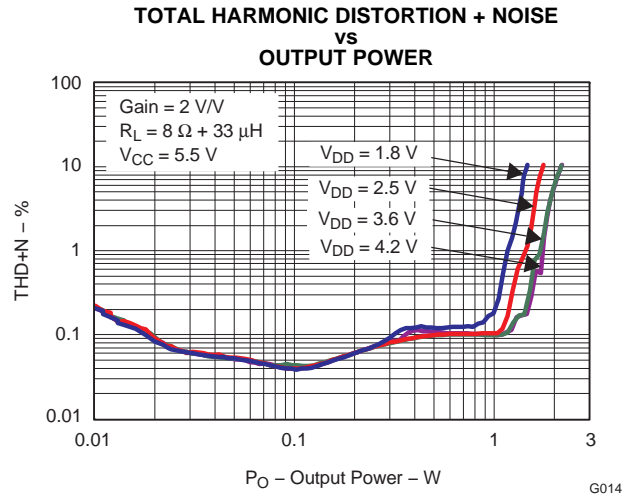

Figure 14.

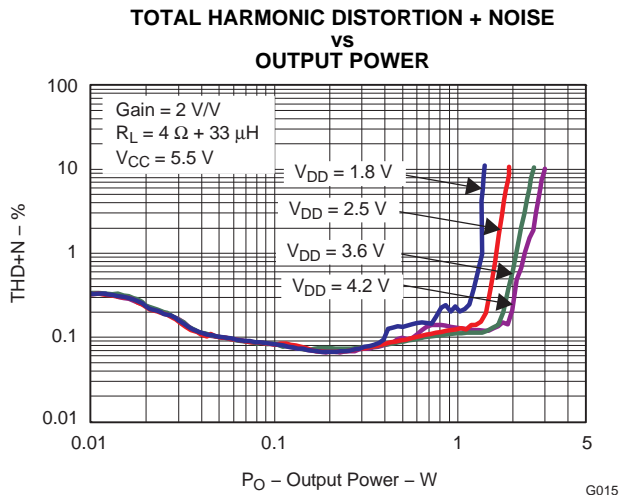

Figure 15.

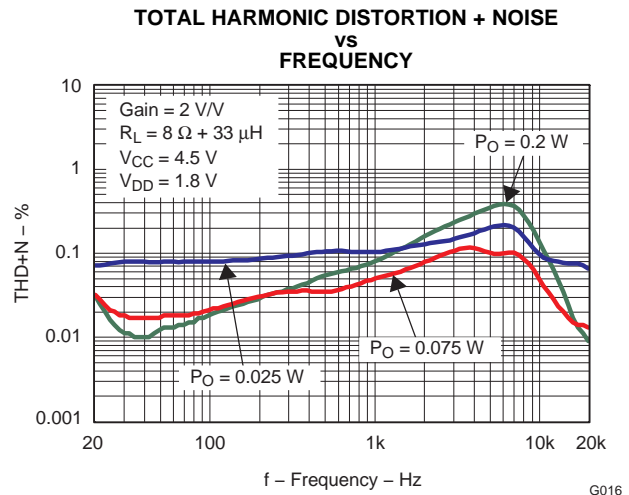

Figure 16.

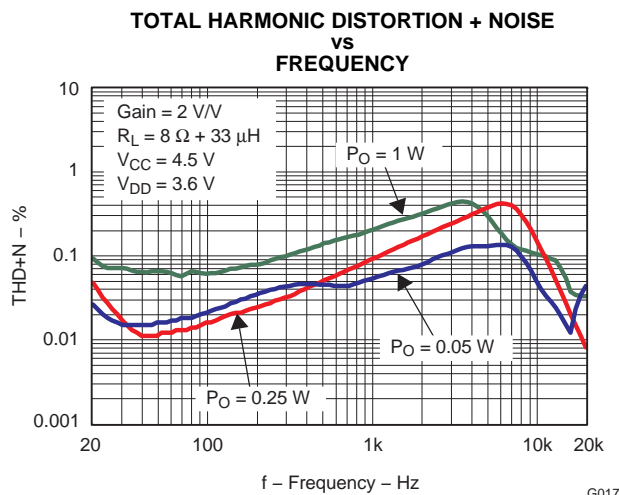

Figure 17.

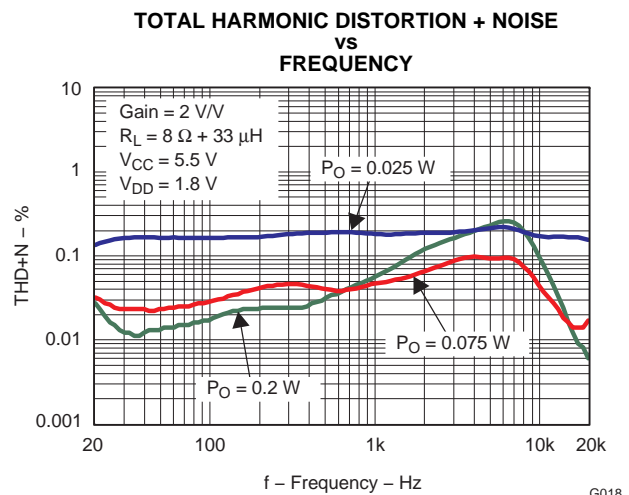

Figure 18.

TYPICAL CHARACTERISTICS (continued)

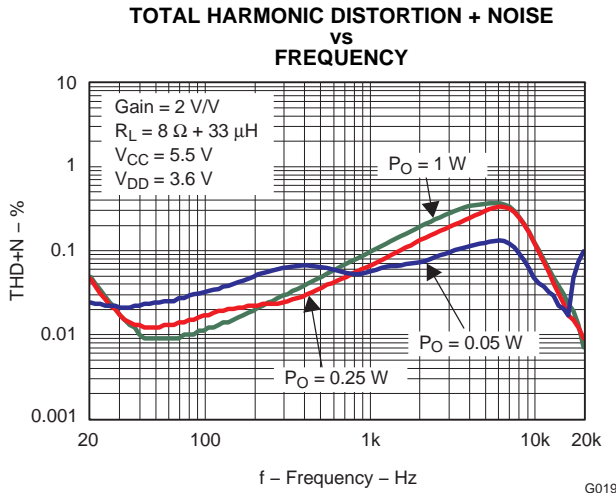

Figure 19.

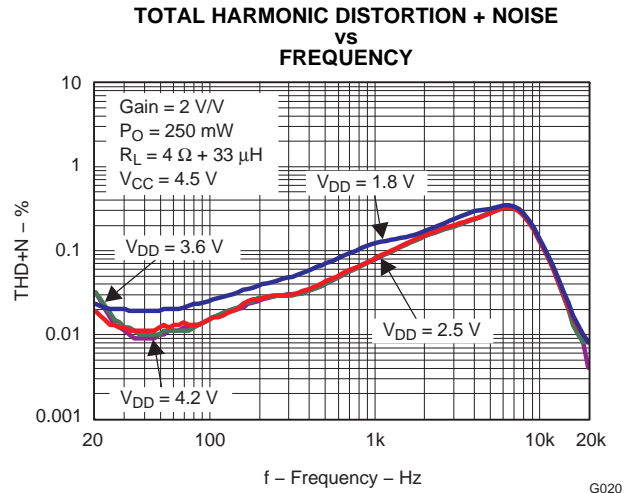

Figure 20.

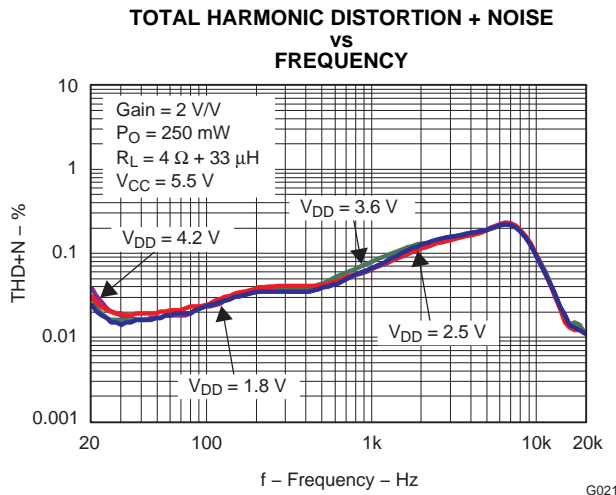

Figure 21.

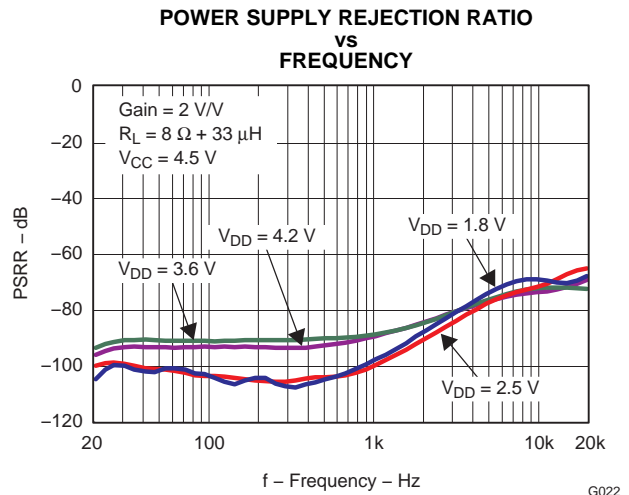

Figure 22.

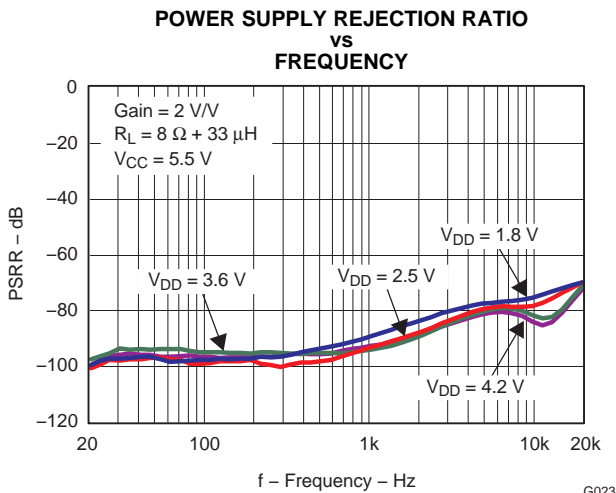

Figure 23.

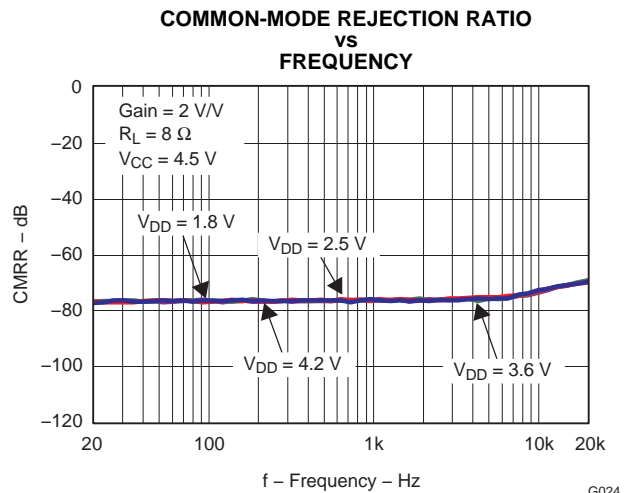

Figure 24.

TYPICAL CHARACTERISTICS (continued)

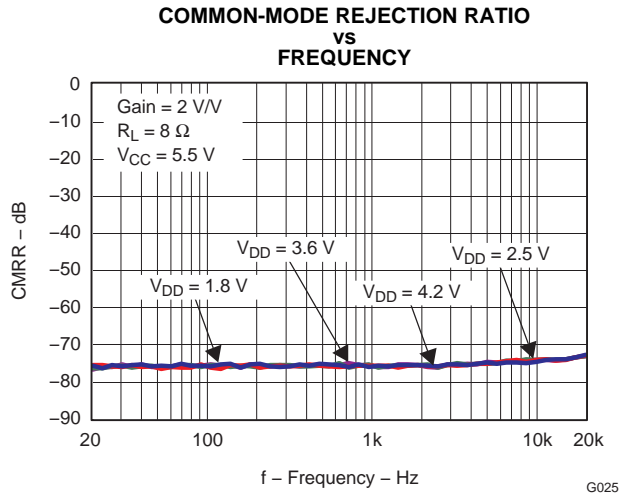

Figure 25.

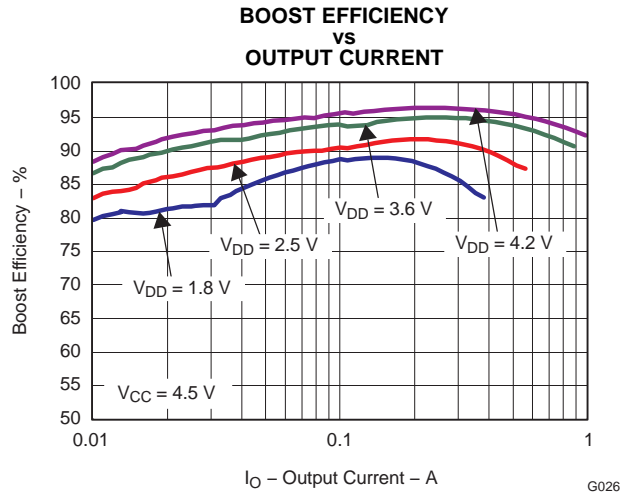

Figure 26.

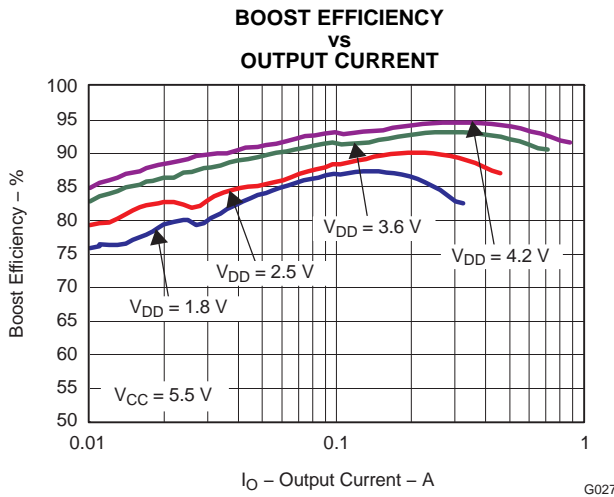

Figure 27.

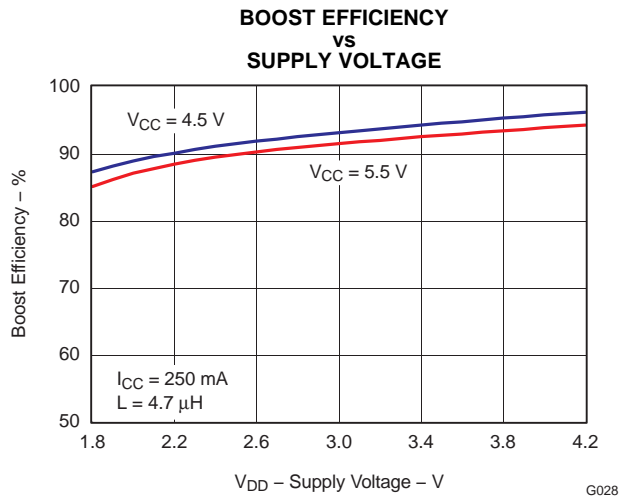

Figure 28.

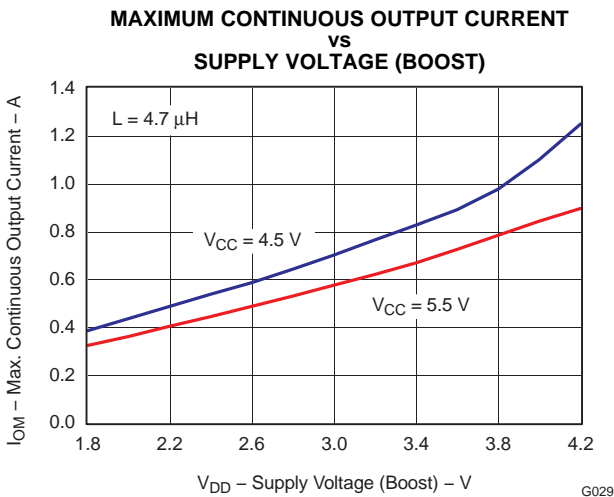

Figure 29.

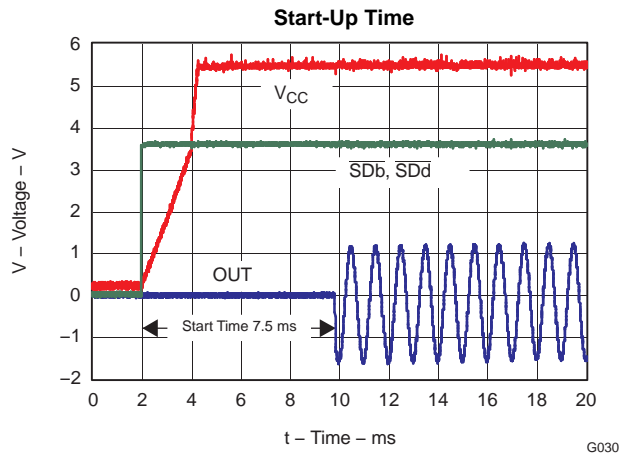

Figure 30.

APPLICATION INFORMATION

FULLY DIFFERENTIAL AMPLIFIER

The TPA2013D1 is a fully differential amplifier with differential inputs and outputs. The fully differential amplifier consists of a differential amplifier with common-mode feedback. The differential amplifier ensures that the amplifier outputs a differential voltage on the output that is equal to the differential input times the gain. The common-mode feedback ensures that the common-mode voltage at the output is biased around $V_{CC}/2$ regardless of the common-mode voltage at the input. The fully differential TPA2013D1 can still be used with a single-ended input; however, the TPA2013D1 should be used with differential inputs when in a noisy environment, like a wireless handset, to ensure maximum noise rejection.

Advantages of Fully Differential Amplifiers

- Input-coupling capacitors not required:
 - The fully differential amplifier allows the inputs to be biased at voltage other than mid-supply. The inputs of the TPA2013D1 can be biased anywhere within the common mode input voltage range listed in the Recommended Operating Conditions table. If the inputs are biased outside of that range, input-coupling capacitors are required.
- Midsupply bypass capacitor, $C_{(BYPASS)}$, not required:
 - The fully differential amplifier does not require a bypass capacitor. Any shift in the midsupply affects both positive and negative channels equally and cancels at the differential output.
- Better RF-immunity:
 - GSM handsets save power by turning on and shutting off the RF transmitter at a rate of 217 Hz. The transmitted signal is picked-up on input and output traces. The fully differential amplifier cancels the signal better than the typical audio amplifier.

BOOST CONVERTER

The TPA2013D1 consists of a boost converter and a Class-D amplifier. The boost converter takes a low supply voltage, V_{DD} , and increases it to a higher output voltage, V_{CC} . V_{CC} is the power supply for the Class-D amplifier.

The two main passive components necessary for the boost converter are the boost inductor and the boost capacitor. The boost inductor stores current, and the boost capacitor stores charge. As the Class-D amplifier depletes the charge in the boost capacitor, the boost inductor charges it back up with the stored current. The cycle of charge/discharge occurs at a frequency of f_{boost} .

The TPA2013D1 allows a range of V_{CC} voltages, including setting V_{CC} lower than V_{DD} .

Boost Terms

The following is a list of terms and definitions used in the boost equations found later in this document.

C	Minimum boost capacitance required for a given ripple voltage on V_{CC} .
L	Boost inductor
f_{boost}	Switching frequency of the boost converter.
I_{CC}	Current pulled by the Class-D amplifier from the boost converter.
I_L	Average current through the boost inductor.
R1 and R2	Resistors used to set the boost voltage.
V_{CC}	Boost voltage. Generated by the boost converter. Voltage supply for the Class-D amplifier.
V_{DD}	Supply voltage to the IC.
ΔI_L	Ripple current through the inductor.
ΔV	Ripple voltage on V_{CC} due to capacitance.

SETTING THE BOOST VOLTAGE

Use [Equation 1](#) to determine the value of R1 for a given V_{CC} . The maximum recommended value for V_{CC} is 5.5 V. The typical value of the V_{CCFB} pin is 500 mV. The current through the resistor divider should be about 100 times greater than the current into the V_{CCFB} pin, typically 0.01 μ A. Based on those two values, the recommended value of R2 is 500 k Ω . V_{CC} must be greater than 3 V and less than or equal to 5.5 V.

$$V_{CC} = \left(\frac{0.5 \times (R1 + R2)}{R1} \right) \quad (1)$$

INDUCTOR SELECTION

SURFACE MOUNT INDUCTORS

Working inductance decreases as inductor current increases. If the drop in working inductance is severe enough, it may cause the boost converter to become unstable, or cause the TPA2013D1 to reach its current limit at a lower output power than expected. Inductor vendors specify currents at which inductor values decrease by a specific percentage. This can vary by 10% to 35%. Inductance is also affected by dc current and temperature.

TPA2013D1 INDUCTOR EQUATIONS

Inductor current rating is determined by the requirements of the load. The inductance is determined by two factors: the minimum value required for stability and the maximum ripple current permitted in the application.

Use [Equation 2](#) to determine the required current rating. [Equation 2](#) shows the approximate relationship between the average inductor current, I_L , to the load current, load voltage, and input voltage (I_{CC} , V_{CC} , and V_{DD} , respectively). Insert I_{CC} , V_{CC} , and V_{DD} into [Equation 2](#) to solve for I_L . The inductor must maintain at least 90% of its initial inductance value at this current.

$$I_L = I_{CC} \times \left(\frac{V_{CC}}{V_{DD} \times 0.8} \right) \quad (2)$$

The minimum working inductance is 2.2 μ H. A lower value may cause instability.

Ripple current, ΔI_L , is peak-to-peak variation in inductor current. Smaller ripple current reduces core losses in the inductor as well as the potential for EMI. Use [Equation 3](#) to determine the value of the inductor, L. [Equation 3](#) shows the relationship between inductance L, V_{DD} , V_{CC} , the switching frequency, f_{boost} , and ΔI_L . Insert the maximum acceptable ripple current into [Equation 3](#) to solve for L.

$$L = \frac{V_{DD} \times (V_{CC} - V_{DD})}{\Delta I_L \times f_{boost} \times V_{CC}} \quad (3)$$

ΔI_L is inversely proportional to L. Minimize ΔI_L as much as is necessary for a specific application. Increase the inductance to reduce the ripple current. Note that making the inductance too large will prevent the boost converter from responding to fast load changes properly. Typical inductor values for the TPA2013D1 are 4.7 μ H to 6.8 μ H.

Select an inductor with a small dc resistance, DCR. DCR reduces the output power due to the voltage drop across the inductor.

CAPACITOR SELECTION

SURFACE MOUNT CAPACITORS

Temperature and applied dc voltage influence the actual capacitance of high-K materials.

Table 3 shows the relationship between the different types of high-K materials and their associated tolerances, temperature coefficients, and temperature ranges. Notice that a capacitor made with X5R material can lose up to 15% of its capacitance within its working temperature range.

High-K material is very sensitive to applied dc voltage. X5R capacitors can have losses ranging from 15 to 45% of their initial capacitance with only half of their dc rated voltage applied. For example, if 5 Vdc is applied to a 10 V, 1 μ F X5R capacitor, the measured capacitance at that point may show 0.85 μ F, 0.55 μ F, or somewhere in between. Y5V capacitors have losses that can reach or exceed 50% to 75% of their rated value.

In an application, the working capacitance of components made with high-K materials is generally much lower than nominal capacitance. A worst case result with a typical X5R material might be -10% tolerance, -15% temperature effect, and -45% dc voltage effect at 50% of the rated voltage. This particular case would result in a working capacitance of 42% ($0.9 \times 0.85 \times 0.55$) of the nominal value.

Select high-K ceramic capacitors according to the following rules:

1. Use capacitors made of materials with temperature coefficients of X5R, X7R, or better.
2. Use capacitors with dc voltage ratings of at least twice the application voltage. Use minimum 10 V capacitors for the TPA2013D1.
3. Choose a capacitance value at least twice the nominal value calculated for the application. Multiply the nominal value by a factor of 2 for safety. If a 10 μ F capacitor is required, use 20 μ F.

The preceding rules and recommendations apply to capacitors used in connection with the TPA2013D1. The TPA2013D1 cannot meet its performance specifications if the rules and recommendations are not followed.

Table 3. Typical tolerance and temperature coefficient of capacitance by material

Material	COG/NPO	X7R	X5R
Typical Tolerance	$\pm 5\%$	$\pm 10\%$	80/–20%
Temperature Coefficient	± 30 ppm	$\pm 15\%$	22/–82%
Temperature Range, °C	–55/125°C	–55/125°C	–30/85°C

TPA2013D1 CAPACITOR EQUATIONS

The value of the boost capacitor is determined by the minimum value of working capacitance required for stability and the maximum voltage ripple allowed on V_{CC} in the application. The minimum value of working capacitance is 10 μF . Do not use any component with a working capacitance less than 10 μF .

For X5R or X7R ceramic capacitors, [Equation 4](#) shows the relationship between the boost capacitance, C , to load current, load voltage, ripple voltage, input voltage, and switching frequency (I_{CC} , V_{CC} , ΔV , V_{DD} , f_{boost} respectively). Insert the maximum allowed ripple voltage into [Equation 4](#) to solve for C . A factor of 2 is included to implement the rules and specifications listed earlier.

$$C = 2 \times \frac{I_{CC} \times (V_{CC} - V_{DD})}{\Delta V \times f_{\text{boost}} \times V_{CC}} \quad (4)$$

For aluminum or tantalum capacitors, [Equation 5](#) shows the relationship between the boost capacitance, C , to load current, load voltage, ripple voltage, input voltage, and switching frequency (I_{CC} , V_{CC} , ΔV , V_{DD} , f_{boost} respectively). Insert the maximum allowed ripple voltage into [Equation 5](#) to solve for C . Solve this equation assuming ESR is zero.

$$C = \frac{I_{CC} \times (V_{CC} - V_{DD})}{\Delta V \times f_{\text{boost}} \times V_{CC}} \quad (5)$$

Capacitance of aluminum and tantalum capacitors is normally not sensitive to applied voltage so there is no factor of 2 included in [Equation 5](#). However, the ESR in aluminum and tantalum capacitors can be significant. Choose an aluminum or tantalum capacitor with ESR around 30 $\text{m}\Omega$. For best performance using of tantalum capacitor, use at least a 10 V rating. Note that tantalum capacitors must generally be used at voltages of half their ratings or less.

RECOMMENDED INDUCTOR AND CAPACITOR VALUES BY APPLICATION

Use [Table 4](#) as a guide for determining the proper inductor and capacitor values.

Table 4. Recommended Values

Class-D Output Power (W) ⁽¹⁾	Class-D Load (Ω)	Minimum V _{DD} (V)	Required V _{CC} (V)	Max I _L (A)	L (μH)	Inductor Vendor Part Numbers	Max ΔV (mVpp)	C ⁽²⁾ (μF)	Capacitor Vendor Part Numbers
1	8	3	4.3	0.70	3.3	Toko DE2812C Coilcraft DO3314 Murata LQH3NPN3R3NG0	30	10	Kemet C1206C106K8PACTU Murata GRM32ER61A106KA01B Taiyo Yuden LMK316BJ106ML-T
					4.7			22	
1.6	8	3	5.5	1.13	4.7	Murata LQH32PN4R7NN0 Toko DE4514C Coilcraft LPS4018-472	30	22	Murata GRM32ER71A226KE20L Taiyo Yuden LMK316BJ226ML-T
					3.3			33	
2	4	3	4.6	1.53	3.3	Murata LQH55PN3R3NR0 Toko DE4514C	30	33	TDK C4532X5R1A336M
					6.2			47	
2.3	4	1.8	5.5	2	6.2	Sumida CDRH5D28NP-6R2NC	30	47	Murata GRM32ER61A476KE20L Taiyo Yuden LMK325BJ476MM-T

(1) All power levels are calculated at 1% THD unless otherwise noted

(2) All values listed are for ceramic capacitors. The correction factor of 2 is included in the values.

CLASS-D REQUIREMENTS

DECOUPLING CAPACITORS

The TPA2013D1 is a high-performance Class-D audio amplifier that requires adequate power supply decoupling to ensure the efficiency is high and total harmonic distortion (THD) is low. Place a low equivalent-series-resistance (ESR) ceramic capacitor, typically 1 μF as close as possible to the device VDD lead. This choice of capacitor and placement helps with higher frequency transients, spikes, or digital hash on the line. Additionally, placing this decoupling capacitor close to the TPA2013D1 is important for the efficiency of the Class-D amplifier, because any resistance or inductance in the trace between the device and the capacitor can cause a loss in efficiency. Place a capacitor of 10 μF or greater between the power supply and the boost inductor. The capacitor filters out high frequency noise. More importantly, it acts as a charge reservoir, providing energy more quickly than the board supply, thus helping to prevent any droop.

INPUT CAPACITORS

The TPA2013D1 does not require input coupling capacitors if the design uses a differential source that is biased within the common mode input range. Use input coupling capacitors if the input signal is not biased within the recommended common-mode input range, if high pass filtering is needed, or if using a single-ended source.

The input capacitors and input resistors form a high-pass filter with the corner frequency, f_c , determined in [Equation 6](#).

$$f_c = \frac{1}{(2 \times \pi \times R_I C_I)} \quad (6)$$

The value of the input capacitor is important to consider as it directly affects the bass (low frequency) performance of the circuit. Speakers in wireless phones cannot usually respond well to low frequencies, so the corner frequency can be set to block low frequencies in this application. Not using input capacitors can increase output offset.

Use [Equation 7](#) to find the required the input coupling capacitance.

$$C_1 = \frac{1}{(2 \times \pi \times f_c \times R_1)} \tag{7}$$

Any mismatch in capacitance between the two inputs will cause a mismatch in the corner frequencies. Choose capacitors with a tolerance of ±10% or better.

FILTER FREE OPERATION AND FERRITE BEAD FILTERS

A ferrite bead filter can often be used if the design is failing radiated emissions without an LC filter and the frequency sensitive circuit is greater than 1 MHz. This filter functions well for circuits that just have to pass FCC and CE because FCC and CE only test radiated emissions greater than 30 MHz. When choosing a ferrite bead, choose one with high impedance at high frequencies, and very low impedance at low frequencies. In addition, select a ferrite bead with adequate current rating to prevent distortion of the output signal.

Use an LC output filter if there are low frequency (< 1 MHz) EMI sensitive circuits and/or there are long leads from amplifier to speaker.

Figure 31 shows a typical ferrite bead output filters.

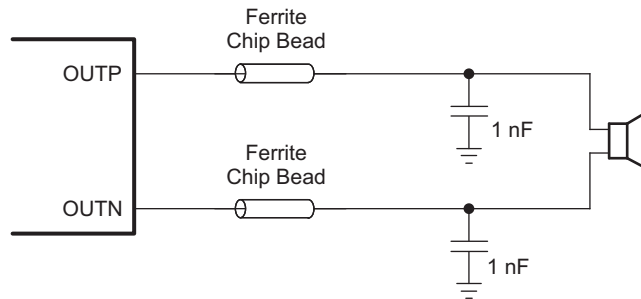

Figure 31. Typical Ferrite Chip Bead Filter

Suggested Chip Ferrite Bead

Load	Vendor	Part Number	Size
8 Ω	Murata	BLM18EG121SN1	0603
4 Ω	TDK	MPZ2012S101A	0805

OPERATION WITH DACs AND CODECs

When using switching amplifiers with CODECs and DACs, sometimes there is an increase in the output noise floor from the audio amplifier. This occurs when mixing of the output frequencies of the CODEC/DAC with the switching frequencies of the audio amplifier input stage. The noise increase can be solved by placing a low-pass filter between the CODEC/DAC and audio amplifier. This filters off the high frequencies that cause the problem and allow proper performance.

The TPA2013D1 has a two pole low pass filter at the inputs. The cutoff frequency of the filter is set to approximately 100kHz. The integrated low pass filter of the TPA2013D1 eliminates the need for additional external filtering components. A properly designed additional low pass filter may be added without altering the performance of the device.

STEREO OPERATION APPLICATION

Use the boost converter of the TPA2013D1 to supply the power for another audio amplifier when stereo operation is required. Ensure the gains of the amplifiers match each other. This prevents one channel from sounding louder than the other. Use Equation 1 through Equation 5 to determine R1, R2, boost inductor, and the boost capacitor values. Figure 32 is an example schematic. The TPA2032D1 is a good choice for this application; the gain is internally set to 2 V/V, the power supply is compatible with V_{CC}OUT of the TPA2013D1, and the output power of the TPA2032D1 is on par with the TPA2013D1.

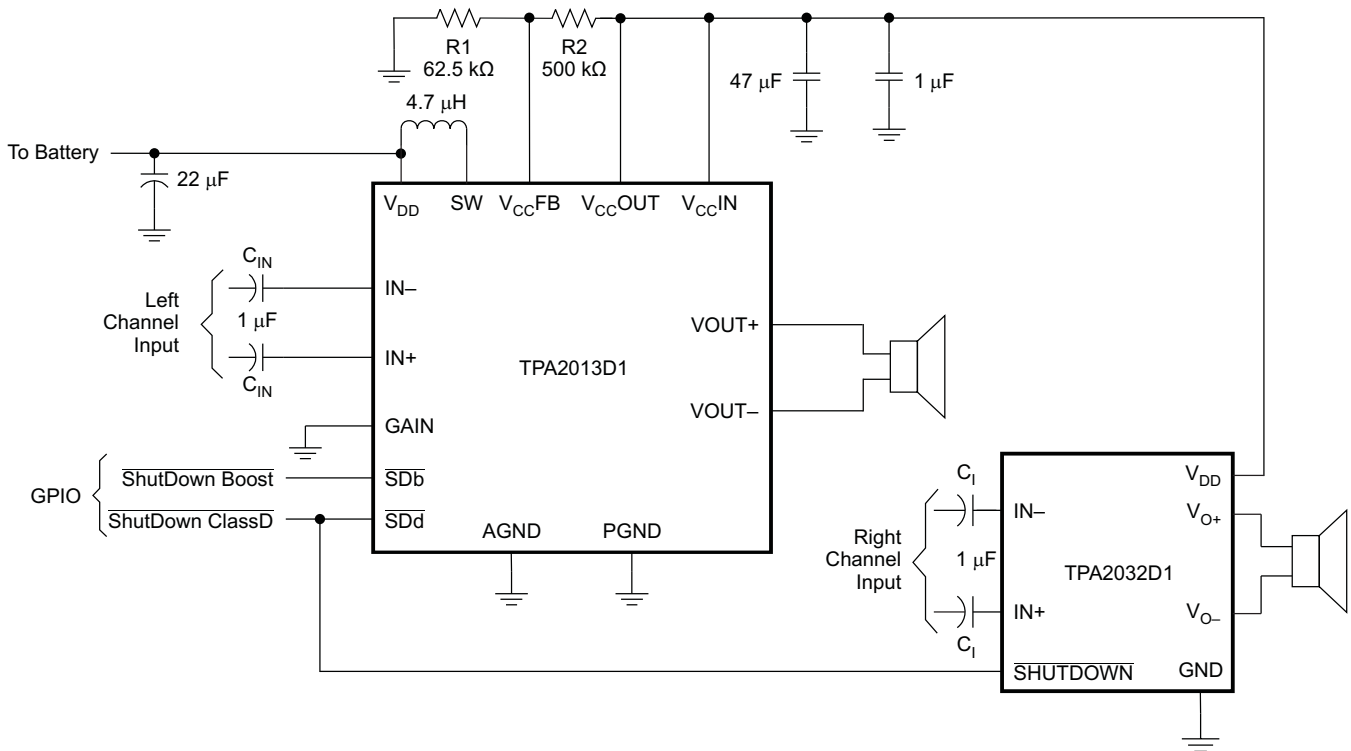

Figure 32. TPA2013D1 in Stereo With the TPA2032D1

LED DRIVER FOR DIGITAL STILL CAMERAS

Use the boost converter of the TPA2013D1 as a power supply for the flash LED of a digital still camera. Use a microprocessor or other device or synchronize the flash to shutter sound that typically comes from the speaker of a digital still camera. Figure 33 shows a typical circuit for this application. LEDs, switches, and other components will vary by application.

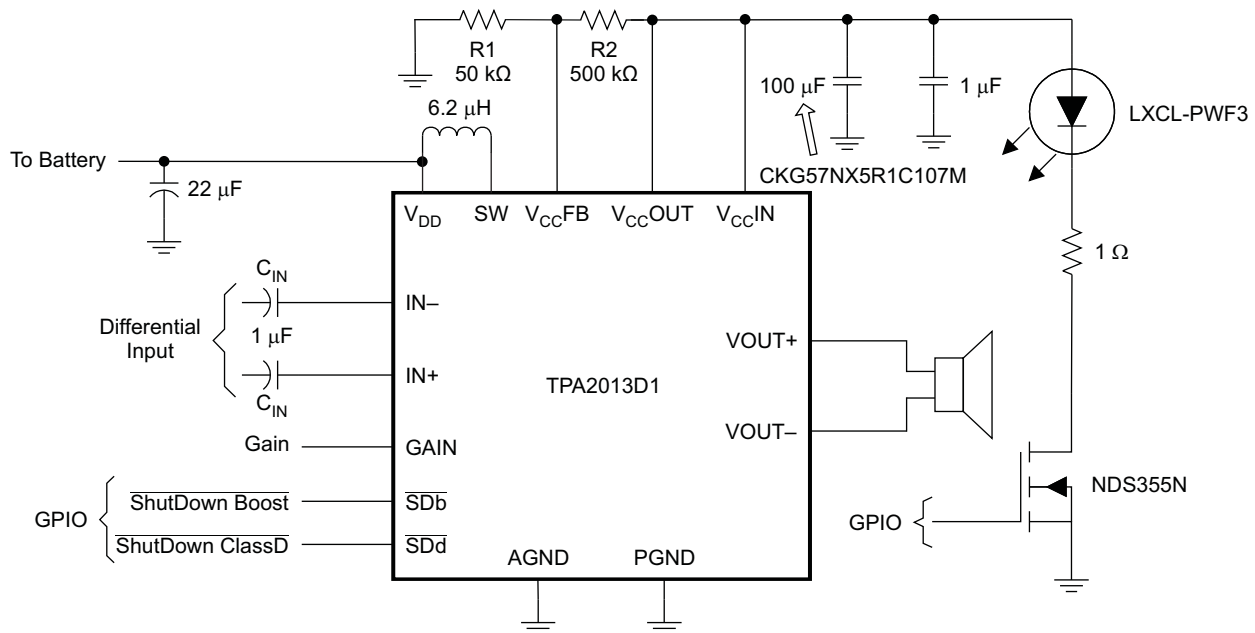

Figure 33. LED Driver

BYPASSING THE BOOST CONVERTER

Bypass the boost converter to drive the Class-D amplifier directly from the battery. Place a Schottky diode between the SW pin and the V_{CC}IN pin. Select a diode that has an average forward current rating of at least 1A, reverse breakdown voltage of 10 V or greater, and a forward voltage as small as possible. See Figure 34 for an example of a circuit designed to bypass the boost converter.

Do not configure the circuit to bypass the boost converter if V_{DD} is higher than V_{CC} when the boost converter is enabled ($\overline{SDb} \geq 1.3$ V); V_{DD} must be lower than V_{CC} for proper operation. V_{DD} may be set to any voltage within the recommended operating range when the boost converter is disabled ($\overline{SDb} \leq 0.3$ V).

Place a logic high on \overline{SDb} to place the TPA2013D1 in boost mode. Place a logic low on \overline{SDb} to place the TPA2013D1 in bypass mode.

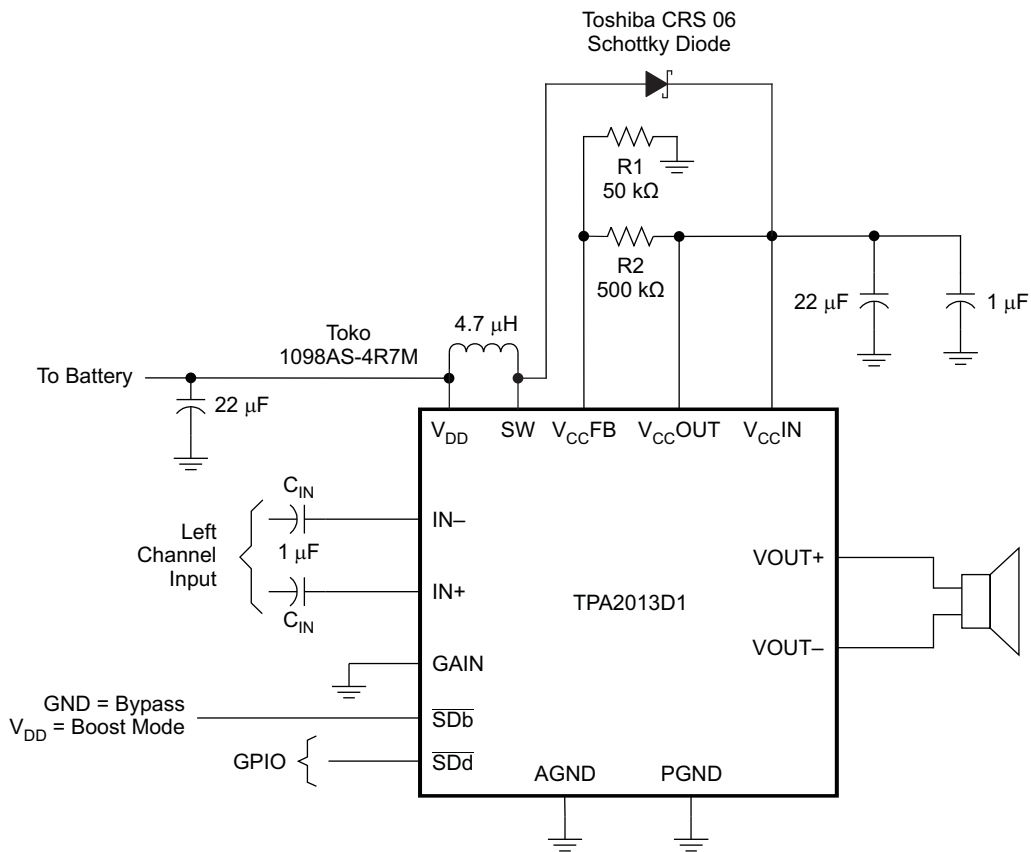

Figure 34. Bypass Circuit

EFFICIENCY AND THERMAL INFORMATION

The maximum ambient temperature depends on the heat-sinking ability of the PCB system. The derating factors for the YZH and RGP packages are shown in the dissipation rating table. Apply the same principles to both packages. Using the YZH package, and converting this to θ_{JA} :

$$\theta_{JA} = \frac{1}{\text{Derating Factor}} = \frac{1}{0.0124} = 80.64^{\circ}\text{C/W} \tag{8}$$

Given θ_{JA} of 80.64°C/W, the maximum allowable junction temperature of 150°C, and the maximum internal dissipation of 0.317 W (V_{DD} = 3.6 V, P_O = 1.7 W), the maximum ambient temperature is calculated with the following equation:

$$T_{A\text{Max}} = T_{J\text{Max}} - \theta_{JA}P_{D\text{max}} = 150 - 80.64 (0.317) = 124^{\circ}\text{C} \quad (9)$$

Equation 9 shows that the calculated maximum ambient temperature is 124°C at maximum power dissipation under the above conditions. The TPA2013D1 is designed with thermal protection that turns the device off when the junction temperature surpasses 150°C to prevent damage to the IC. Also, using speakers more resistive than 4-Ω dramatically increases the thermal performance by reducing the output current and increasing the efficiency of the amplifier.

BOARD LAYOUT

In making the pad size for the WCSP balls, use nonsolder mask defined (NSMD) land. With this method, the solder mask opening is made larger than the desired land area, and the opening size is defined by the copper pad width. Figure 35 and Table 5 show the appropriate diameters for a WCSP layout.

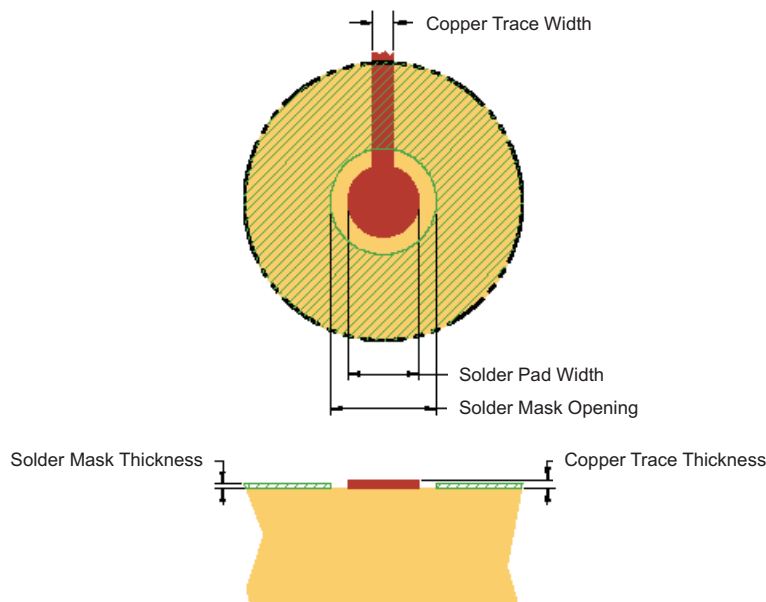

Figure 35. Land Pattern Dimensions

Table 5. Land Pattern Dimensions

SOLDER PAD DEFINITIONS	COPPER PAD	SOLDER MASK OPENING	COPPER THICKNESS	STENCIL OPENING	STENCIL THICKNESS
Nonsolder mask defined (NSMD)	275 μm (+0.0, -25 μm)	375 μm (+0.0, -25 μm)	1 oz max (32 μm)	275 μm x 275 μm Sq. (rounded corners)	125 μm thick

NOTES:

1. Circuit traces from NSMD defined PWB lands should be 75 μm to 100 μm wide in the exposed area inside the solder mask opening. Wider trace widths reduce device stand off and impact reliability.
2. Recommend solder paste is Type 3 or Type 4.
3. Best reliability results are achieved when the PWB laminate glass transition temperature is above the operating range of the intended application.
4. For a PWB using a Ni/Au surface finish, the gold thickness should be less than 0.5 μm to avoid a reduction in thermal fatigue performance.
5. Solder mask thickness should be less than 20 μm on top of the copper circuit pattern.
6. Best solder stencil performance is achieved using laser cut stencils with electro polishing. Use of chemically etched stencils results in inferior solder paste volume control.
7. Trace routing away from WCSP device should be balanced in X and Y directions to avoid unintentional component movement due to solder wetting forces.

Trace Width

Recommended trace width at the solder balls is 75 μm to 100 μm to prevent solder wicking onto wider PCB traces.

For high current pins (SW, PGND, VOUT+, VOUT–, V_{CC}IN, and V_{CC}OUT) of the TPA2013D1, use 100 μm trace widths at the solder balls and at least 500 μm PCB traces to ensure proper performance and output power for the device.

For low current pins (IN–, IN+, $\overline{\text{SDd}}$, $\overline{\text{SDb}}$, GAIN, V_{CC}FB, V_{DD}) of the TPA2013D1, use 75 μm to 100 μm trace widths at the solder balls. Run IN– and IN+ traces side-by-side to maximize common-mode noise cancellation.

PACKAGING INFORMATION

Orderable Device	Status ⁽¹⁾	Package Type	Package Drawing	Pins	Package Qty	Eco Plan ⁽²⁾	Lead/Ball Finish	MSL Peak Temp ⁽³⁾
TPA2013D1RGPT	PREVIEW	QFN	RGP	20	250	TBD	Call TI	Call TI
TPA2013D1YZHR	ACTIVE	DSBGA	YZH	16	3000	Green (RoHS & no Sb/Br)	SNAGCU	Level-1-260C-UNLIM
TPA2013D1YZHT	PREVIEW	DSBGA	YZH	16	250	TBD	Call TI	Call TI

⁽¹⁾ The marketing status values are defined as follows:

ACTIVE: Product device recommended for new designs.

LIFEBUY: TI has announced that the device will be discontinued, and a lifetime-buy period is in effect.

NRND: Not recommended for new designs. Device is in production to support existing customers, but TI does not recommend using this part in a new design.

PREVIEW: Device has been announced but is not in production. Samples may or may not be available.

OBSOLETE: TI has discontinued the production of the device.

⁽²⁾ Eco Plan - The planned eco-friendly classification: Pb-Free (RoHS), Pb-Free (RoHS Exempt), or Green (RoHS & no Sb/Br) - please check <http://www.ti.com/productcontent> for the latest availability information and additional product content details.

TBD: The Pb-Free/Green conversion plan has not been defined.

Pb-Free (RoHS): TI's terms "Lead-Free" or "Pb-Free" mean semiconductor products that are compatible with the current RoHS requirements for all 6 substances, including the requirement that lead not exceed 0.1% by weight in homogeneous materials. Where designed to be soldered at high temperatures, TI Pb-Free products are suitable for use in specified lead-free processes.

Pb-Free (RoHS Exempt): This component has a RoHS exemption for either 1) lead-based flip-chip solder bumps used between the die and package, or 2) lead-based die adhesive used between the die and leadframe. The component is otherwise considered Pb-Free (RoHS compatible) as defined above.

Green (RoHS & no Sb/Br): TI defines "Green" to mean Pb-Free (RoHS compatible), and free of Bromine (Br) and Antimony (Sb) based flame retardants (Br or Sb do not exceed 0.1% by weight in homogeneous material)

⁽³⁾ MSL, Peak Temp. -- The Moisture Sensitivity Level rating according to the JEDEC industry standard classifications, and peak solder temperature.

Important Information and Disclaimer:The information provided on this page represents TI's knowledge and belief as of the date that it is provided. TI bases its knowledge and belief on information provided by third parties, and makes no representation or warranty as to the accuracy of such information. Efforts are underway to better integrate information from third parties. TI has taken and continues to take reasonable steps to provide representative and accurate information but may not have conducted destructive testing or chemical analysis on incoming materials and chemicals. TI and TI suppliers consider certain information to be proprietary, and thus CAS numbers and other limited information may not be available for release.

In no event shall TI's liability arising out of such information exceed the total purchase price of the TI part(s) at issue in this document sold by TI to Customer on an annual basis.

MECHANICAL DATA

RGP (S-PQFP-N20)

PLASTIC QUAD FLATPACK

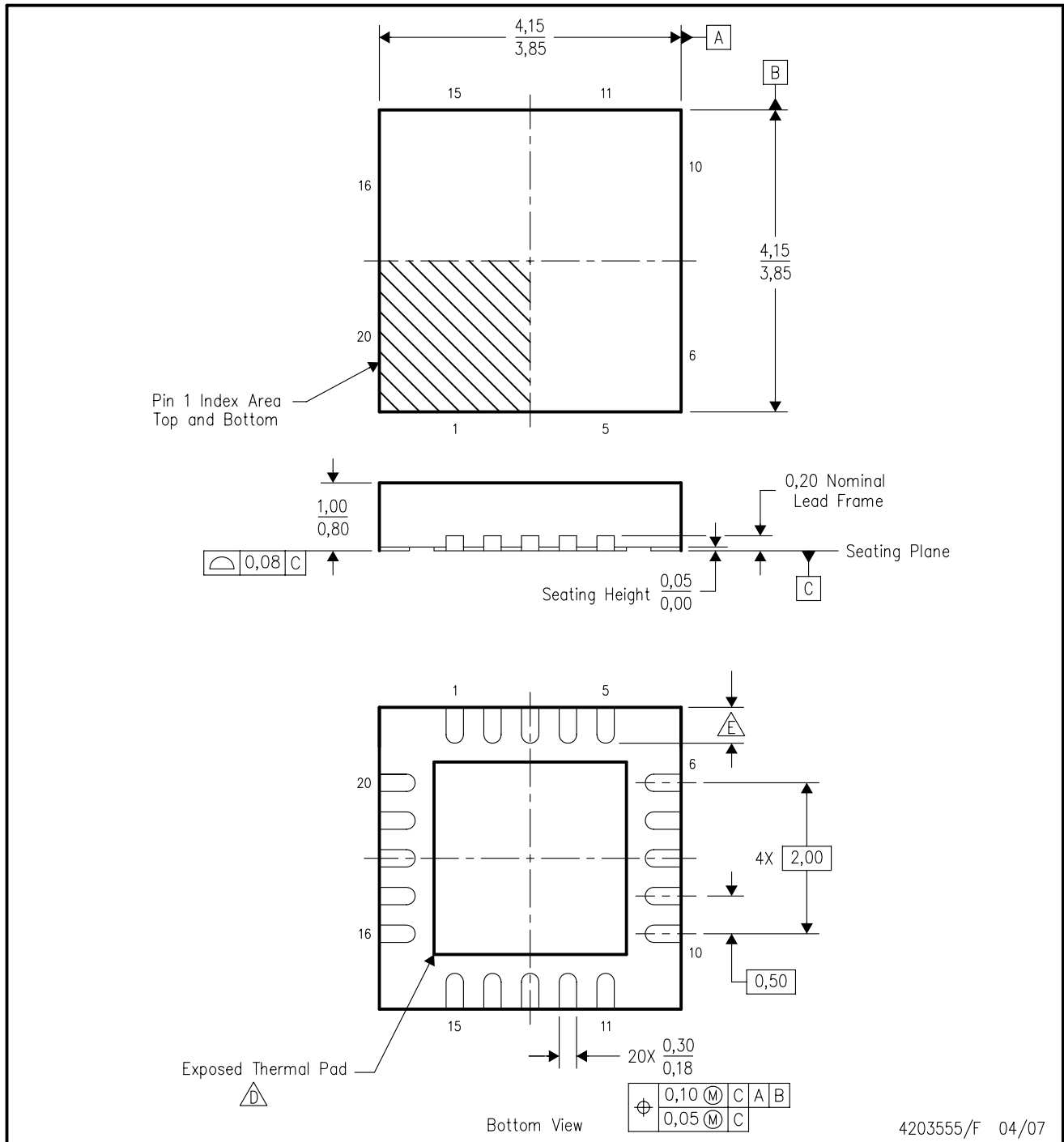

4203555/F 04/07

- NOTES:
- A. All linear dimensions are in millimeters. Dimensioning and tolerancing per ASME Y14.5M-1994.
 - B. This drawing is subject to change without notice.
 - C. QFN (Quad Flatpack No-Lead) package configuration.
 - The package thermal pad must be soldered to the board for thermal and mechanical performance. See the Product Data Sheet for details regarding the exposed thermal pad dimensions.
 - Check thermal pad mechanical drawing in the product datasheet for nominal lead length dimensions.

THERMAL INFORMATION

This package incorporates an exposed thermal pad that is designed to be attached directly to an external heatsink. The thermal pad must be soldered directly to the printed circuit board (PCB). After soldering, the PCB can be used as a heatsink. In addition, through the use of thermal vias, the thermal pad can be attached directly to a ground or power plane (whichever is applicable), or alternatively, a special heatsink structure designed into the PCB. This design optimizes the heat transfer from the integrated circuit (IC).

For information on the Quad Flatpack No-Lead (QFN) package and its advantages, refer to Application Report, Quad Flatpack No-Lead Logic Packages, Texas Instruments Literature No. SCBA017. This document is available at www.ti.com.

The exposed thermal pad dimensions for this package are shown in the following illustration.

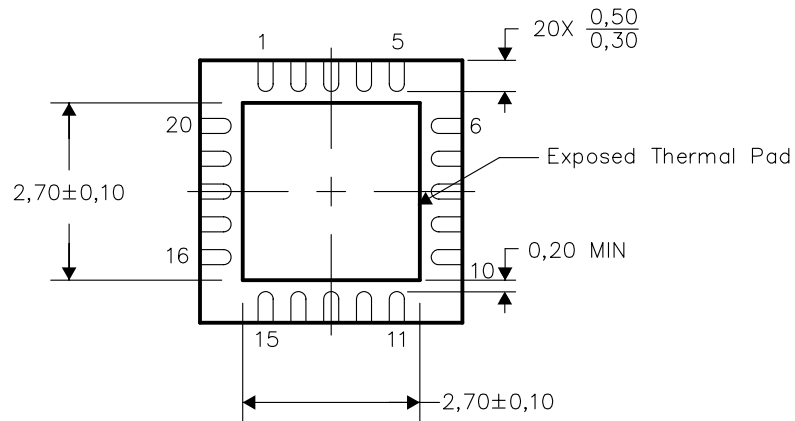

Bottom View

NOTE: All linear dimensions are in millimeters

Exposed Thermal Pad Dimensions

RGP (S-PQFP-N20)

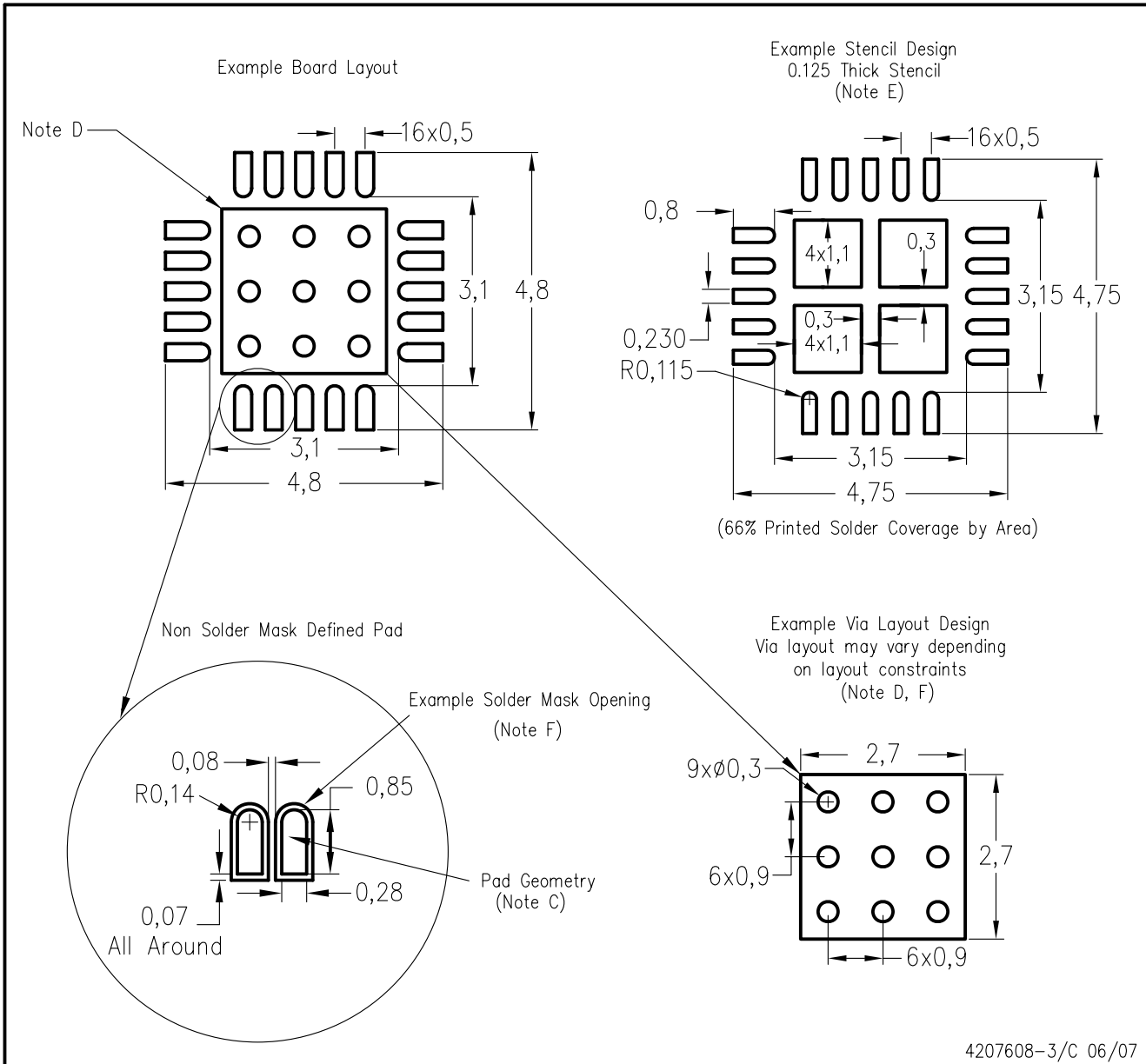

- NOTES:
- All linear dimensions are in millimeters.
 - This drawing is subject to change without notice.
 - Publication IPC-7351 is recommended for alternate designs.
 - This package is designed to be soldered to a thermal pad on the board. Refer to Application Note, Quad Flat-Pack Packages, Texas Instruments Literature No. SCBA017, SLUA271, and also the Product Data Sheets for specific thermal information, via requirements, and recommended board layout. These documents are available at www.ti.com <<http://www.ti.com>>.
 - Laser cutting apertures with trapezoidal walls and also rounding corners will offer better paste release. Customers should contact their board assembly site for stencil design recommendations. Refer to IPC 7525 for stencil design considerations.
 - Customers should contact their board fabrication site for recommended solder mask tolerances and via tenting recommendations for vias placed in the thermal pad.

YZH (S-XBGA-N16)

DIE-SIZE BALL GRID ARRAY

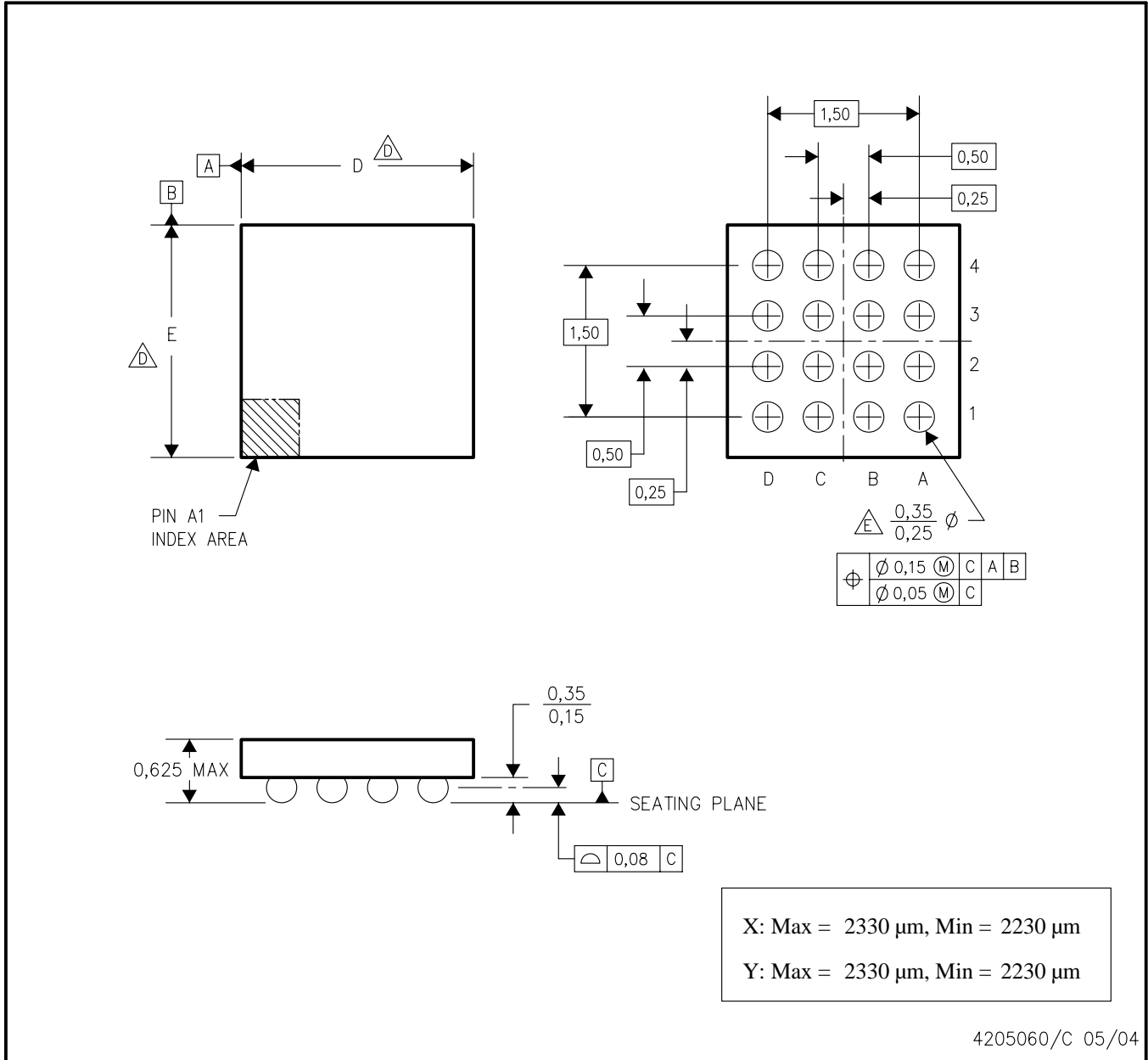

- NOTES:
- A. All linear dimensions are in millimeters.
 - B. This drawing is subject to change without notice.
 - C. NanoFree™ package configuration.
 - Devices in YZH package can have dimension D ranging from 1.85 to 2.65 mm and dimension E ranging from 1.85 to 2.65 mm. To determine the exact package size of a particular device, refer to the device datasheet or contact a local TI representative.
 - Reference Product Data Sheet for array population. 4 x 4 matrix pattern is shown for illustration only.
 - F. This package contains lead-free balls. Refer to YEH (Drawing #4204183) for tin-lead (SnPb) balls.

IMPORTANT NOTICE

Texas Instruments Incorporated and its subsidiaries (TI) reserve the right to make corrections, modifications, enhancements, improvements, and other changes to its products and services at any time and to discontinue any product or service without notice. Customers should obtain the latest relevant information before placing orders and should verify that such information is current and complete. All products are sold subject to TI's terms and conditions of sale supplied at the time of order acknowledgment.

TI warrants performance of its hardware products to the specifications applicable at the time of sale in accordance with TI's standard warranty. Testing and other quality control techniques are used to the extent TI deems necessary to support this warranty. Except where mandated by government requirements, testing of all parameters of each product is not necessarily performed.

TI assumes no liability for applications assistance or customer product design. Customers are responsible for their products and applications using TI components. To minimize the risks associated with customer products and applications, customers should provide adequate design and operating safeguards.

TI does not warrant or represent that any license, either express or implied, is granted under any TI patent right, copyright, mask work right, or other TI intellectual property right relating to any combination, machine, or process in which TI products or services are used. Information published by TI regarding third-party products or services does not constitute a license from TI to use such products or services or a warranty or endorsement thereof. Use of such information may require a license from a third party under the patents or other intellectual property of the third party, or a license from TI under the patents or other intellectual property of TI.

Reproduction of TI information in TI data books or data sheets is permissible only if reproduction is without alteration and is accompanied by all associated warranties, conditions, limitations, and notices. Reproduction of this information with alteration is an unfair and deceptive business practice. TI is not responsible or liable for such altered documentation. Information of third parties may be subject to additional restrictions.

Resale of TI products or services with statements different from or beyond the parameters stated by TI for that product or service voids all express and any implied warranties for the associated TI product or service and is an unfair and deceptive business practice. TI is not responsible or liable for any such statements.

TI products are not authorized for use in safety-critical applications (such as life support) where a failure of the TI product would reasonably be expected to cause severe personal injury or death, unless officers of the parties have executed an agreement specifically governing such use. Buyers represent that they have all necessary expertise in the safety and regulatory ramifications of their applications, and acknowledge and agree that they are solely responsible for all legal, regulatory and safety-related requirements concerning their products and any use of TI products in such safety-critical applications, notwithstanding any applications-related information or support that may be provided by TI. Further, Buyers must fully indemnify TI and its representatives against any damages arising out of the use of TI products in such safety-critical applications.

TI products are neither designed nor intended for use in military/aerospace applications or environments unless the TI products are specifically designated by TI as military-grade or "enhanced plastic." Only products designated by TI as military-grade meet military specifications. Buyers acknowledge and agree that any such use of TI products which TI has not designated as military-grade is solely at the Buyer's risk, and that they are solely responsible for compliance with all legal and regulatory requirements in connection with such use.

TI products are neither designed nor intended for use in automotive applications or environments unless the specific TI products are designated by TI as compliant with ISO/TS 16949 requirements. Buyers acknowledge and agree that, if they use any non-designated products in automotive applications, TI will not be responsible for any failure to meet such requirements.

Following are URLs where you can obtain information on other Texas Instruments products and application solutions:

Products		Applications	
Amplifiers	amplifier.ti.com	Audio	www.ti.com/audio
Data Converters	dataconverter.ti.com	Automotive	www.ti.com/automotive
DSP	dsp.ti.com	Broadband	www.ti.com/broadband
Interface	interface.ti.com	Digital Control	www.ti.com/digitalcontrol
Logic	logic.ti.com	Military	www.ti.com/military
Power Mgmt	power.ti.com	Optical Networking	www.ti.com/opticalnetwork
Microcontrollers	microcontroller.ti.com	Security	www.ti.com/security
RFID	www.ti-rfid.com	Telephony	www.ti.com/telephony
Low Power Wireless	www.ti.com/lpw	Video & Imaging	www.ti.com/video
		Wireless	www.ti.com/wireless