

2-W STEREO AUDIO POWER AMPLIFIER WITH DirectPath™ STEREO HEADPHONE DRIVE AND REGULATOR

FEATURES

- Microsoft™ Windows Vista™ Compliant
- Fully Differential Architecture and High PSRR Provide Excellent RF Rectification Immunity
- 2-W, 10% THD+N Into 4-Ω Speakers and 85-mW, 1% THD+N Into 16-Ω Headphones From 5-V Supply
- DirectPath™ Headphone Amplifier Eliminates Output Capacitors ⁽¹⁾
- Internal 4-Step Speaker Gain Control: 6, 10, 15.6, 21.6 dB and Fixed -1.5-V/V Headphone
- 3.3-V Low Dropout Regulator for CODEC
- Independent Shutdown Controls for Speaker, Headphone Amplifier, and Low Dropout Regulator (LDO)
- Output Short-Circuit and Thermal Protection

DESCRIPTION

The TPA6043A4 is a stereo audio power amplifier and DirectPath™ headphone amplifier in a thermally enhanced, space-saving, 32-pin QFN package. The speaker amplifier is capable of driving 2 W per channel continuously into 4-Ω loads at 5 V. The headphone amplifier achieves a minimum of 85 mW at 1% THD+N from a 5-V supply. A built-in internal 4-step gain control for the speaker amplifier and a fixed -1.5 V/V gain for the headphone amplifier minimizes external components needed.

Independent shutdown control and dedicated inputs for the speaker and headphone allow the TPA6043A4 to simultaneously drive both headphones and internal speakers. Differential inputs to the speaker amplifiers offer superior power-supply and common-mode noise rejection.

APPLICATIONS

- Notebook Computers
- Portable DVD

(1) US Patent Number 5289137

SIMPLIFIED APPLICATION CIRCUIT

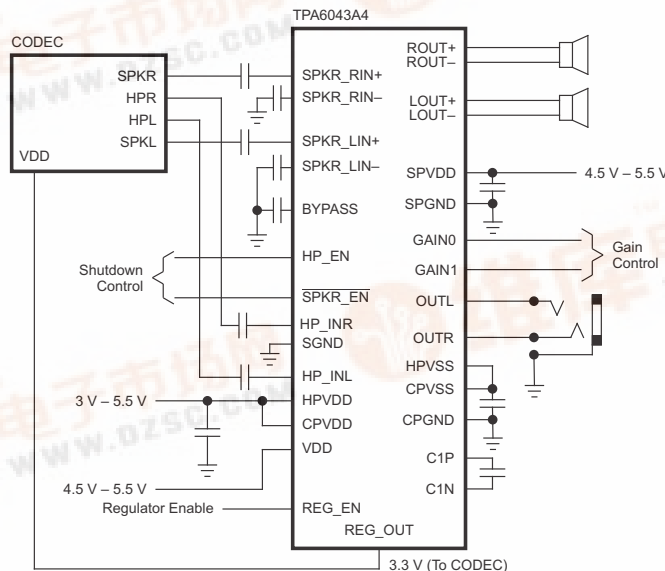

Please be aware that an important notice concerning availability, standard warranty, and use in critical applications of Texas Instruments semiconductor products and disclaimers thereto appears at the end of this data sheet.

DirectPath, PowerPAD are trademarks of Texas Instruments.
Microsoft, Windows Vista are trademarks of Microsoft Corporation.



These devices have limited built-in ESD protection. The leads should be shorted together or the device placed in conductive foam during storage or handling to prevent electrostatic damage to the MOS gates.

Functional Block Diagram

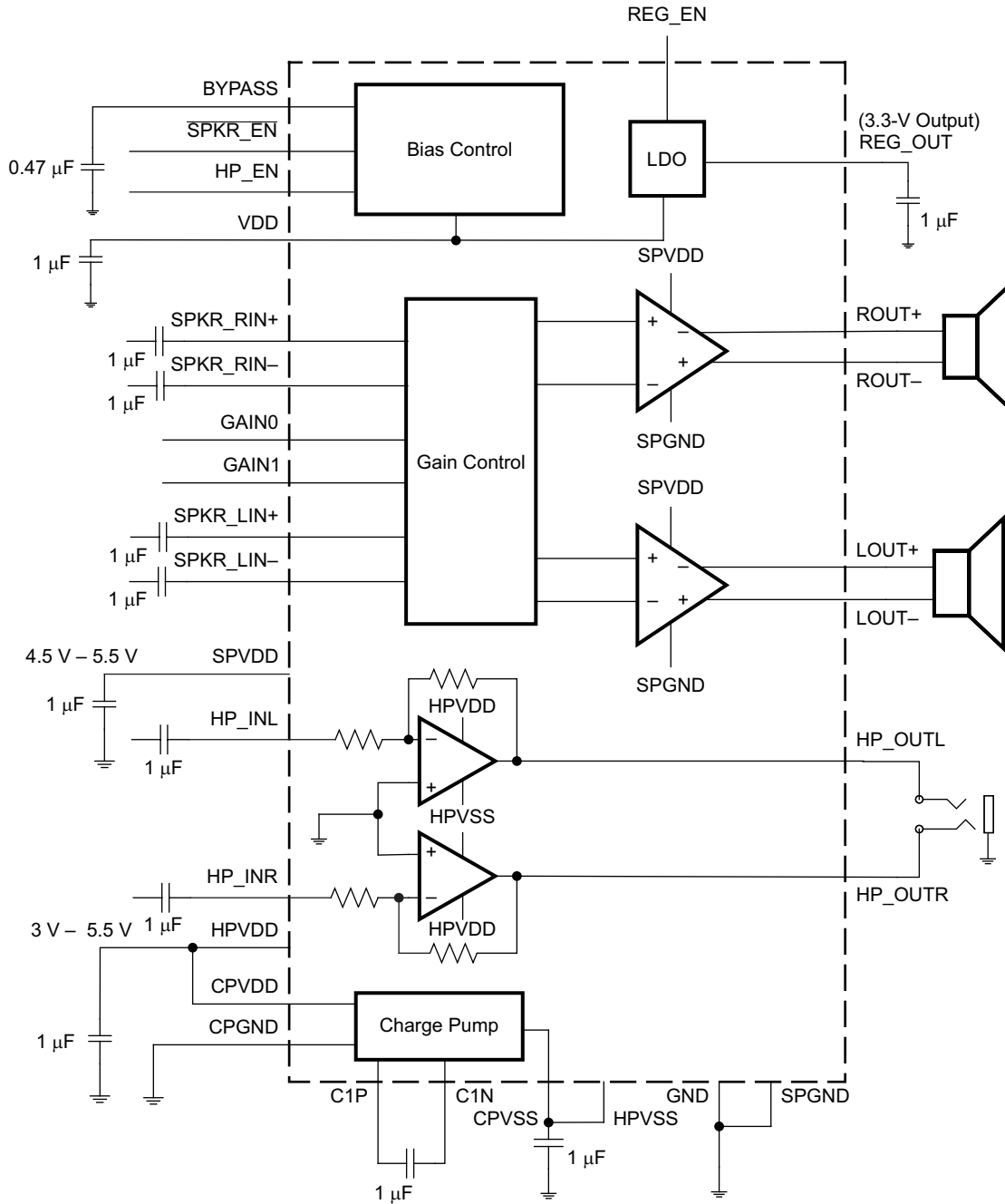

AVAILABLE PACKAGE OPTIONS

| T _A | PACKAGED DEVICE ⁽¹⁾⁽²⁾ 32-Pin QFN (RHB) | SYMBOL |
|----------------|---|--------|
| –40°C to 85°C | TPA6043A4RHB | RHB |

- (1) The RHB package is available taped and reeled. To order a taped and reeled part, add the suffix R to the part number (e.g., TPA6043A4RHBR).
- (2) For the most current package and ordering information, see the Package Option Addendum at the end of this document, or see the TI website at www.ti.com.

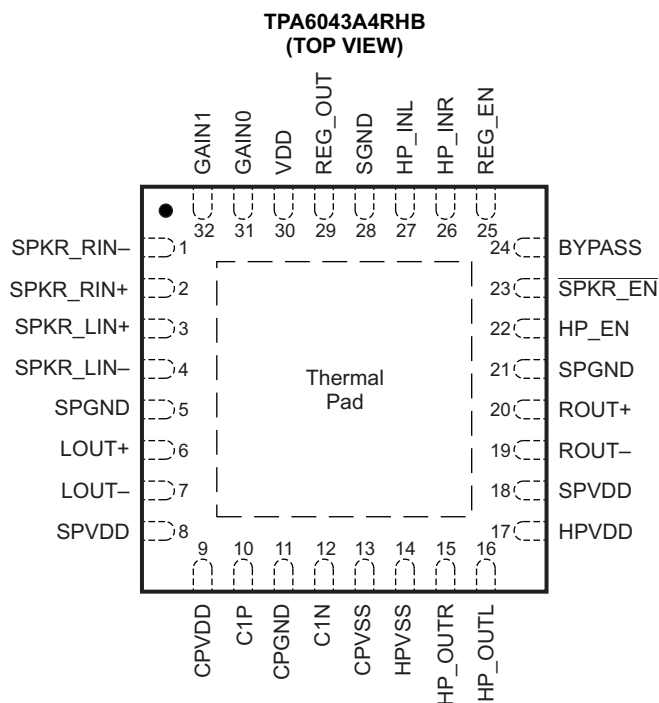

TERMINAL FUNCTIONS

| TERMINAL NAME | NO. | I/O/P | DESCRIPTION |
|------------------|-------|-------|--|
| SPKR_RIN– | 1 | I | Right-channel negative differential audio input for speaker amplifier |
| SPKR_RIN+ | 2 | I | Right-channel positive differential audio input for speaker amplifier |
| SPKR_LIN+ | 3 | I | Left-channel positive differential audio input for speaker amplifier |
| SPKR_LIN– | 4 | I | Left-channel negative differential audio input for speaker amplifier |
| SPGND | 5, 21 | P | Speaker power ground |
| LOU+ | 6 | O | Left-channel positive audio output |
| LOU– | 7 | O | Left-channel negative audio output |
| SPVDD | 8, 18 | P | Supply voltage terminal for speaker amplifier |
| CPVDD | 9 | P | Charge pump positive supply, connect to HPVDD via star connection |
| C1P | 10 | I/O | Charge pump flying capacitor positive terminal |
| CPGND | 11 | P | Charge pump ground |
| C1N | 12 | I/O | Charge pump flying capacitor negative terminal |
| CPVSS | 13 | P | Charge pump output (negative supply for headphone amplifier), connect to HPVSS |
| HPVSS | 14 | P | Headphone amplifier negative supply, connect to CPVSS |
| HP_OUTR | 15 | O | Right-channel capacitor-free headphone output |
| HP_OUTL | 16 | O | Left-channel capacitor-free headphone output |
| HPVDD | 17 | P | Headphone amplifier supply voltage, connect to CPVDD |
| ROUT– | 19 | O | Right-channel negative audio output |

TERMINAL FUNCTIONS (continued)

| TERMINAL | | I/O/P | DESCRIPTION |
|------------------------------|---------|-------|--|
| NAME | NO. | | |
| ROUT+ | 20 | O | Right-channel positive audio output |
| HP_EN | 22 | I | Headphone channel enable logic input; active high enable. HIGH=ENABLE. |
| $\overline{\text{SPKR_EN}}$ | 23 | I | Speaker channel enable logic input; active low enable. LOW=ENABLE. |
| BYPASS | 24 | P | Common-mode bias voltage for speaker preamplifiers |
| REG_EN | 25 | I | Enable pin (Active HIGH) for turning on/off LDO. HIGH=ENABLE |
| HP_INR | 26 | I | Headphone right-channel audio input |
| HP_INL | 27 | I | Headphone left-channel audio input |
| SGND | 28 | P | Signal ground, connect to CPGND and SPGND |
| REG_OUT | 29 | O | Regulated 3.3-V output |
| VDD | 30 | P | Positive power supply |
| GAIN0 | 31 | I | Bit 0, MSB, of gain select bits |
| GAIN1 | 32 | I | Bit 1, LSB, of gain select bits |
| Thermal Pad | Die Pad | P | Solder the thermal pad on the bottom of the QFN package to the GND plane of the PCB. It is required for mechanical stability and will enhance thermal performance. |

ABSOLUTE MAXIMUM RATINGS

over operating free-air temperature range (unless otherwise noted)⁽¹⁾

| | | VALUE | UNIT |
|---|---|------------------------------|------|
| Supply voltage | HPVDD, VDD, SPVDD, CPVDD | –0.3 to 6 | V |
| V _I Input voltage | SPKR_LIN+, SPKR_LIN-, SPKR_RIN+, SPKR_RIN-, HP_EN, GAIN0, GAIN1, SPK_EN, REG_EN | –0.3 to 6.3 | V |
| | HP_INL, HP_INR HP Enabled | –3.5 to 3.5 | |
| | HP_INL, HP_INR HP not Enabled | –0.3 to 3.5 | |
| Continuous total power dissipation | | See Dissipation Rating Table | |
| T _A Operating free-air temperature range | | –40 to 85 | °C |
| T _J Operating junction temperature range | | –40 to 150 | °C |
| T _{stg} Storage temperature range | | –65 to 150 | °C |
| Electrostatic discharge | HBM for HP_OUTL and HP_OUTR | 8 | kV |
| Electrostatic discharge, all other pins | CDM | 500 | V |
| | HBM | 2 | kV |

(1) Stresses beyond those listed under *absolute maximum ratings* may cause permanent damage to the device. These are stress ratings only, and functional operations of the device at these or any other conditions beyond those indicated under *recommended operating conditions* is not implied. Exposure to absolute-maximum-rated conditions for extended periods may affect device reliability.

DISSIPATION RATINGS

| PACKAGE ⁽¹⁾ | T _A ≤ 25°C | DERATING FACTOR | T _A = 70°C | T _A = 85°C |
|------------------------|-----------------------|-----------------|-----------------------|-----------------------|
| RHB | 5.06 W | 40 mW/°C | 4.04 W | 3.23 W |

(1) The PowerPAD™ must be soldered to a thermal land on the printed-circuit board. See the Texas Instruments document, PowerPAD™ Thermally Enhanced Package application report (literature number [SLMA002](#)) for more information regarding the PowerPAD™ package.

RECOMMENDED OPERATING CONDITIONS

| | | MIN | MAX | UNIT |
|--|--|-----|-----|------|
| Supply voltage | VDD, SPVDD | 4.5 | 5.5 | V |
| Supply voltage | HPVDD, CPVDD | 3 | 5.5 | V |
| V _{IH} High-level input voltage | $\overline{\text{SPKR_EN}}$, HP_EN, GAIN0, GAIN1, REG_EN | 2 | | V |
| V _{IL} Low-level input voltage | $\overline{\text{SPKR_EN}}$, HP_EN, GAIN0, GAIN1, REG_EN | | 0.8 | V |

RECOMMENDED OPERATING CONDITIONS (continued)

| | MIN | MAX | UNIT |
|--------------------------------------|-----|-----|------|
| T_A Operating free-air temperature | -40 | 85 | °C |

GENERAL DC ELECTRICAL CHARACTERISTICS
 $T_A = 25^\circ\text{C}$, $V_{DD} = SPVDD = HPVDD = CPVDD = 5\text{ V}$ (unless otherwise noted)

| PARAMETER | TEST CONDITIONS | MIN | TYP | MAX | UNIT |
|---|--|-----|------|-----|---------------|
| I_{IH} High-level input current | $\overline{SPKR_EN}$, HP_EN , $GAIN0$, $GAIN1$, $REG_EN = V_{DD}$ | | 0.02 | 1 | μA |
| I_{IL} Low-level input current | $\overline{SPKR_EN}$, HP_EN , $GAIN0$, $GAIN1$, $REG_EN = 0\text{ V}$ | | 0.02 | 1 | μA |
| $I_{DD(\text{Speaker})}$ Supply current, speaker amplifier ONLY enabled | $\overline{SPKR_EN} = 0\text{ V}$, $HP_EN = REG_EN = 0\text{ V}$ | | 5 | 12 | mA |
| $I_{DD(\text{HP})}$ Supply current, headphone amplifier ONLY enabled | $\overline{SPKR_EN} = HP_EN = 2\text{ V}$, $REG_EN = 0\text{ V}$ | | 7.5 | 14 | mA |
| $I_{DD(\text{REG})}$ Supply current, regulator ONLY enabled | $\overline{SPKR_EN} = REG_EN = 2\text{ V}$, $HP_EN = 0\text{ V}$ | | 0.65 | 1 | mA |
| $I_{DD(\text{SD})}$ Supply current, shutdown mode | $\overline{SPKR_EN} = 2\text{ V}$, $HP_EN = REG_EN = 0\text{ V}$ | | 2.5 | 5 | μA |

SPEAKER AMPLIFIER DC CHARACTERISTICS
 $T_A = 25^\circ\text{C}$, $V_{DD} = SPVDD = 5\text{ V}$, $R_L = 4\ \Omega$, Gain = 6 dB (unless otherwise noted)

| PARAMETER | TEST CONDITIONS | MIN | TYP | MAX | UNIT |
|--|---|-----|-----|-----|------|
| $ V_{OO} $ Output offset voltage (measured differentially) | Inputs AC-coupled to GND, Gain = 6 dB | | 0.5 | 10 | mV |
| PSRR Power supply rejection ratio | $V_{DD} = SPVDD = 4.5\text{ V to }5.5\text{ V}$ | -60 | -74 | | dB |

SPEAKER AMPLIFIER AC CHARACTERISTICS
 $T_A = 25^\circ\text{C}$, $V_{DD} = SPVDD = 5\text{ V}$, $R_L = 4\ \Omega$, Gain = 6 dB (unless otherwise noted)

| PARAMETER | TEST CONDITIONS | MIN | TYP | MAX | UNIT |
|--|--|-----|-------|------|---------------------|
| P_O Output power | THD+N = 1%, $f = 1\text{ kHz}$, $R_L = 8\ \Omega$ | | 1.25 | | W |
| | THD+N = 10%, $f = 1\text{ kHz}$, $R_L = 8\ \Omega$ | | 1.5 | | |
| | THD+N = 1%, $f = 1\text{ kHz}$, $R_L = 4\ \Omega$ | | 2 | | |
| | THD+N = 10%, $f = 1\text{ kHz}$, $R_L = 4\ \Omega$ | | 2.3 | | |
| THD+N Total harmonic distortion plus noise | $P_O = 1\text{ W}$, $R_L = 8\ \Omega$, $f = 20\text{ Hz to }20\text{ kHz}$ | | 0.1% | | |
| | $P_O = 0.5\text{ W}$, $R_L = 8\ \Omega$, $f = 20\text{ Hz to }20\text{ kHz}$ | | 0.08% | | |
| kSVR Supply ripple rejection ratio | $f = 1\text{ kHz}$, $CBYPASS = 0.47\ \mu\text{F}$, $V_{RIPPLE} = 200\text{ mV}_{PP}$ | | -60 | | dB |
| SNR Signal-to-noise rejection ratio | Maximum output at THD+N < 1%, $f = 1\text{ kHz}$, Gain = 6 dB | | 90 | | dB |
| Crosstalk (Left-Right; Right-Left) | $f = 1\text{ kHz}$, $P_O = 1\text{ W}$, Gain = 6 dB | | -80 | | dB |
| | $f = 10\text{ kHz}$, $P_O = 1\text{ W}$, Gain = 6 dB | | -75 | | dB |
| V_n Noise output voltage | $CBYPASS = 0.47\ \mu\text{F}$, $f = 20\text{ Hz to }20\text{ kHz}$, Gain = 6 dB, No weighting | | 30 | | μV_{rms} |
| Z_I Input Impedance | Gain = 21.6 dB | 15 | 20 | | k Ω |
| G Gain | $GAIN0$, $GAIN1 = 0.8\text{ V}$ | 5.4 | 6 | 6.6 | dB |
| | $GAIN0 = 0.8\text{ V}$; $GAIN1 = 2\text{ V}$ | 9.4 | 10 | 10.6 | |
| | $GAIN0 = 2\text{ V}$, $GAIN1 = 0.8\text{ V}$ | 15 | 15.6 | 16.2 | |
| | $GAIN0$, $GAIN1 = 2\text{ V}$ | 21 | 21.6 | 22.2 | |
| Gain Matching | Channel-to Channel | | 0.01 | | dB |
| Start-up time from shutdown | $CBYPASS = 0.47\ \mu\text{F}$ | | 30 | | ms |

HEADPHONE AMPLIFIER DC ELECTRICAL CHARACTERISTICS

$T_A = 25^\circ\text{C}$, $\text{HPVDD} = \text{CPVDD} = \text{VDD} = 5\text{ V}$, $R_L = 16\ \Omega$ (unless otherwise noted)

| PARAMETER | TEST CONDITIONS | MIN | TYP | MAX | UNIT |
|-----------------------------------|------------------------|-----|------|-----|------|
| $ V_{OS} $ Output offset voltage | Inputs grounded | | 1 | 3 | mV |
| PSRR Power supply rejection ratio | HPVDD = 4.5 V to 5.5 V | -75 | -100 | | dB |

HEADPHONE AMPLIFIER AC CHARACTERISTICS

$T_A = 25^\circ\text{C}$, $\text{HPVDD} = 5\text{ V}$, $R_L = 16\ \Omega$ (unless otherwise noted)

| PARAMETER | TEST CONDITIONS | MIN | TYP | MAX | UNIT |
|--|--|-------|-------|-------|----------------------------|
| P_O Output power (outputs in phase) | THD+N = 10%, $R_L = 16\ \Omega$, $f = 1\text{ kHz}$ | | 200 | | mW |
| | THD+N = 10%, $R_L = 32\ \Omega$, $f = 1\text{ kHz}$ | | 100 | | |
| THD+N Total harmonic distortion plus noise | $P_O = 85\text{ mW}$, $f = 20\text{ Hz to }20\text{ kHz}$, $R_L = 16\ \Omega$ | | 0.03% | | |
| | $P_O = 50\text{ mW}$, $f = 20\text{ Hz to }20\text{ kHz}$, $R_L = 32\ \Omega$ | | 0.04% | | |
| Dynamic Range with Signal Present | A-Weighted, $f = 20\text{ Hz to }20\text{ kHz}$ | | -100 | | dB FS |
| kSVR Supply ripple rejection | $f = 1\text{ kHz}$, 200-mV _{PP} ripple | | -60 | | dB |
| Crosstalk | $P_O = 35\text{ mW}$, $f = 20\text{ Hz to }20\text{ kHz}$ | | -80 | | dB |
| SNR Signal-to-noise ratio | Maximum output at THD+N 1%, $f = 1\text{ kHz}$ | | 95 | | dB |
| V_n Noise output voltage | $f = 20\text{ Hz to }20\text{ kHz}$, No weighting | | 20 | | μV_{rms} |
| Z_I Input Impedance | | 15 | 20 | | k Ω |
| Gain Closed-loop voltage gain | $R_L = 16\ \Omega$ | -1.45 | -1.5 | -1.55 | V/V |
| Start-up time from shutdown | | | 5 | | ms |

LDO CHARACTERISTICS

$T_A = 25^\circ\text{C}$, $\text{VDD} = 5\text{ V}$ (unless otherwise noted)

| PARAMETER | TEST CONDITIONS | MIN | TYP | MAX | UNIT |
|---------------------------------|---|-----|------|------|--------|
| V_I Input voltage | V_{DD} | 4.5 | | 5.5 | V |
| I_O Continuous output current | | 120 | | | mA |
| V_O Output voltage | $0 < I_O < 120\text{ mA}$; $4.9\text{ V} < V_I < 5.5\text{ V}$ | 3.2 | 3.3 | 3.4 | V |
| Line regulation | $I_L = 5\text{ mA}$; $4.9\text{ V} < V_I < 5.5\text{ V}$ | | 1.8 | 10 | mV |
| Load regulation | $I_L = 0 - 120\text{ mA}$, $V_I = 5\text{ V}$ | | 0.13 | 0.23 | mV/ mA |
| Power supply ripple rejection | $V_{DD} = 4.9\text{ V}$, $I_L = 10\text{ mA}$ $f = 100\text{ Hz}$ | | 46 | | dB |

TYPICAL CHARACTERISTICS

Default graph conditions: $V_{CC} = 5\text{ V}$, $f_{req} = 1\text{ kHz}$, AES17 Filter.

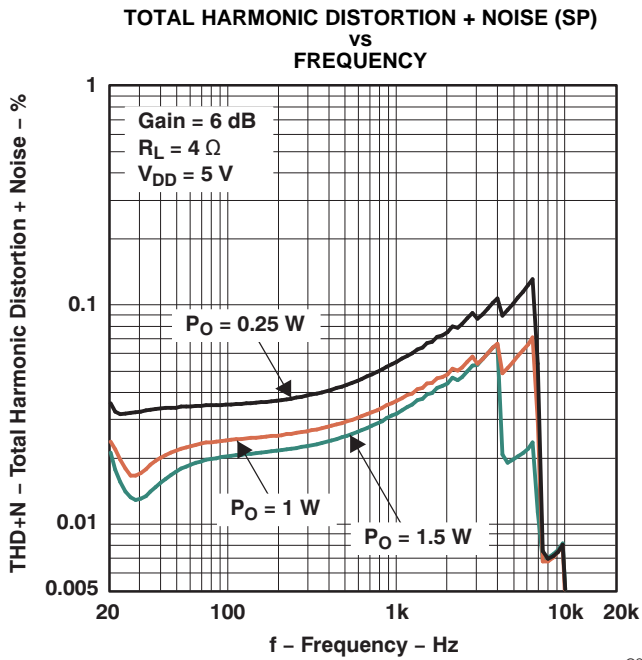

Figure 1.

G001

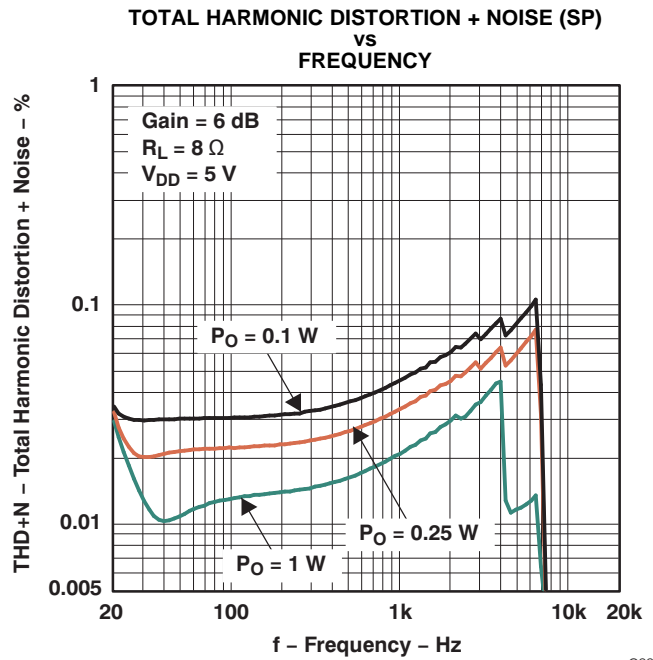

Figure 2.

G002

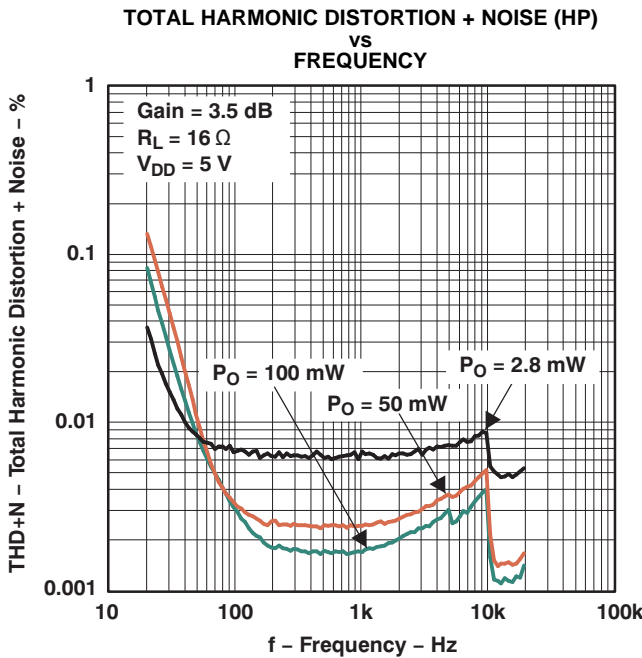

Figure 3.

G003

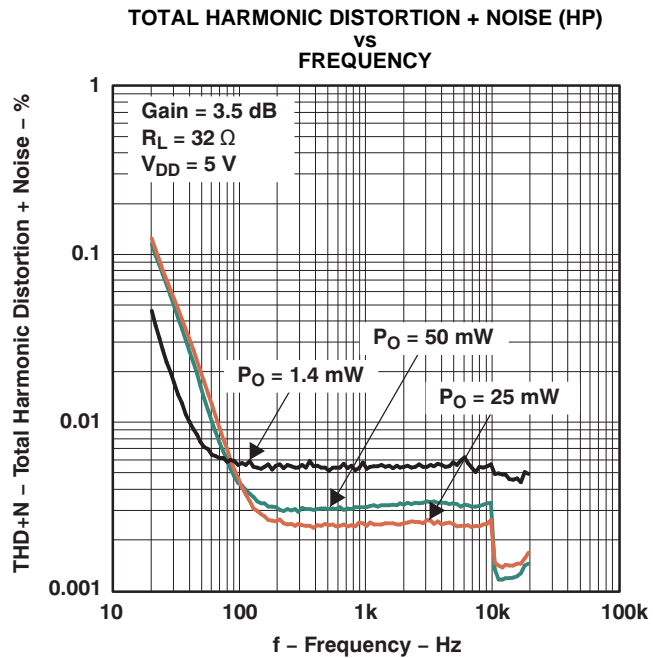

Figure 4.

G004

TYPICAL CHARACTERISTICS (continued)

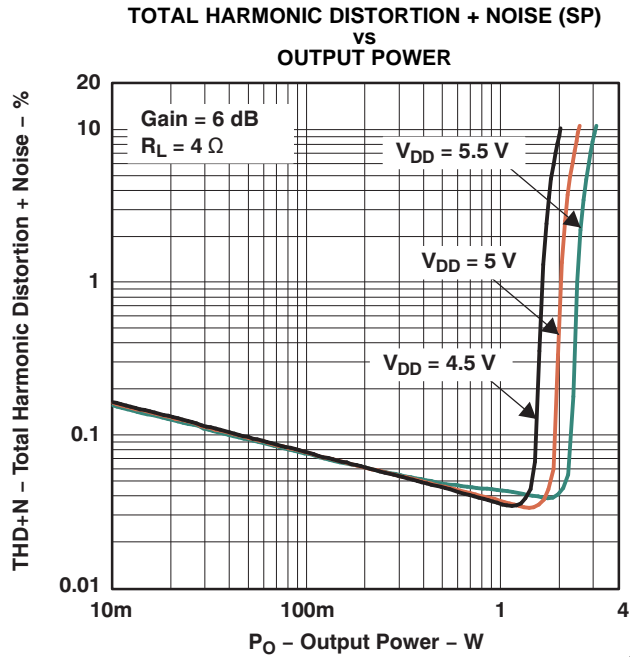

Figure 5.

G005

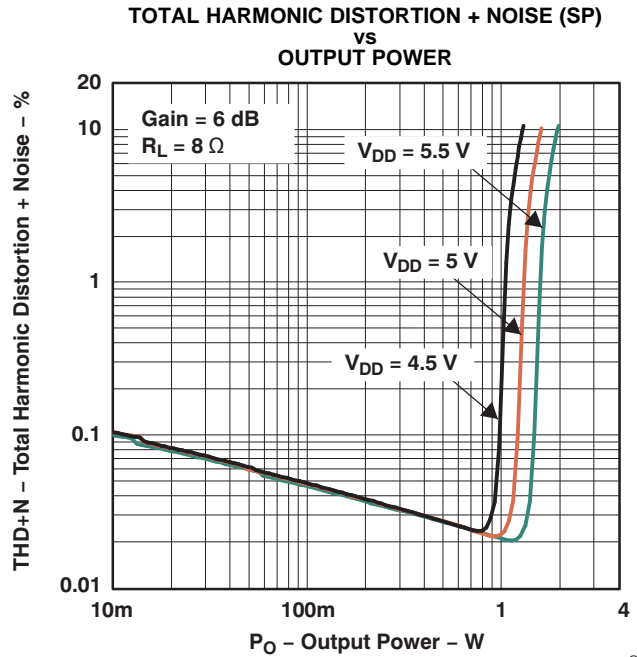

Figure 6.

G006

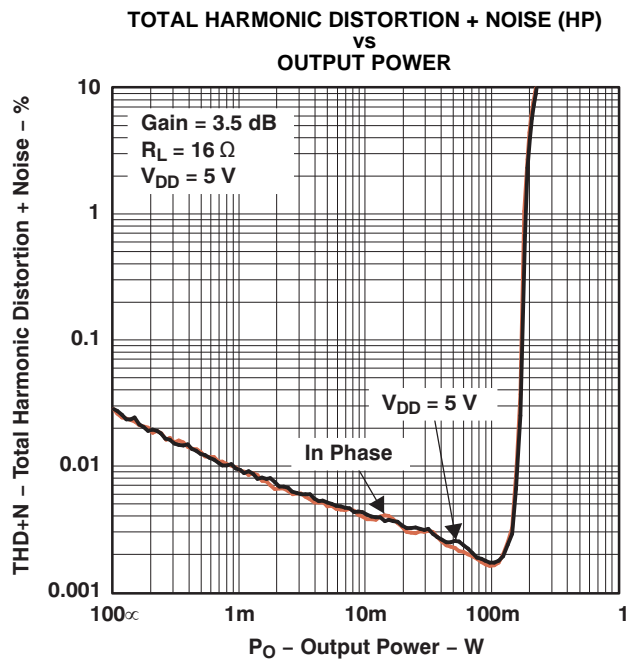

Figure 7.

G007

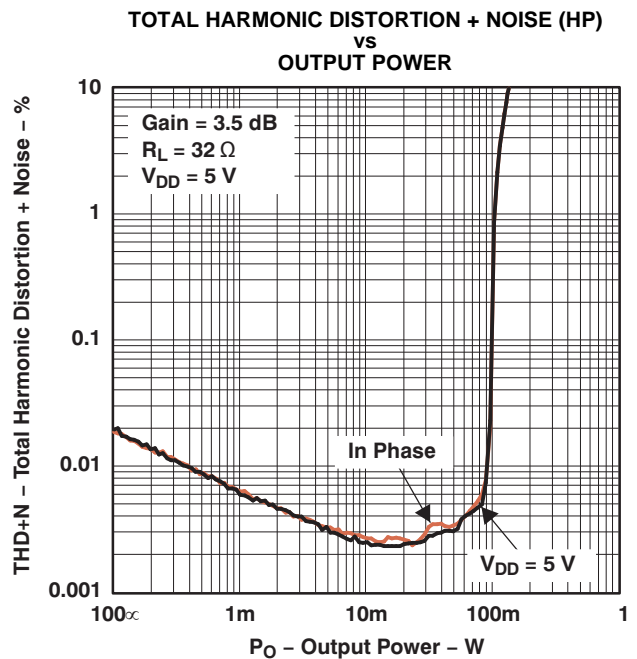

Figure 8.

G008

TYPICAL CHARACTERISTICS (continued)

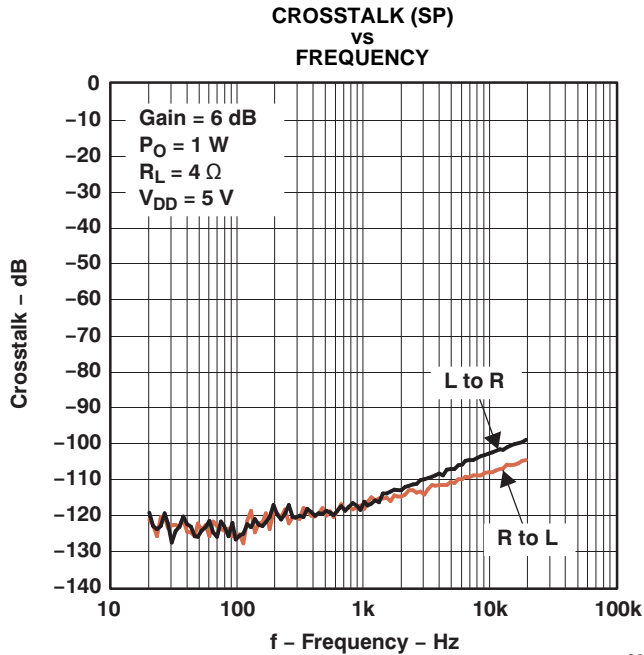

Figure 9.

G009

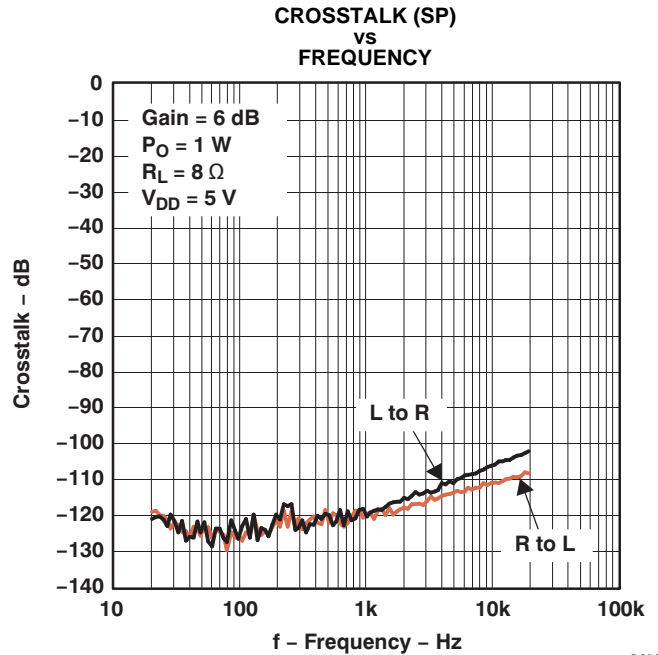

Figure 10.

G010

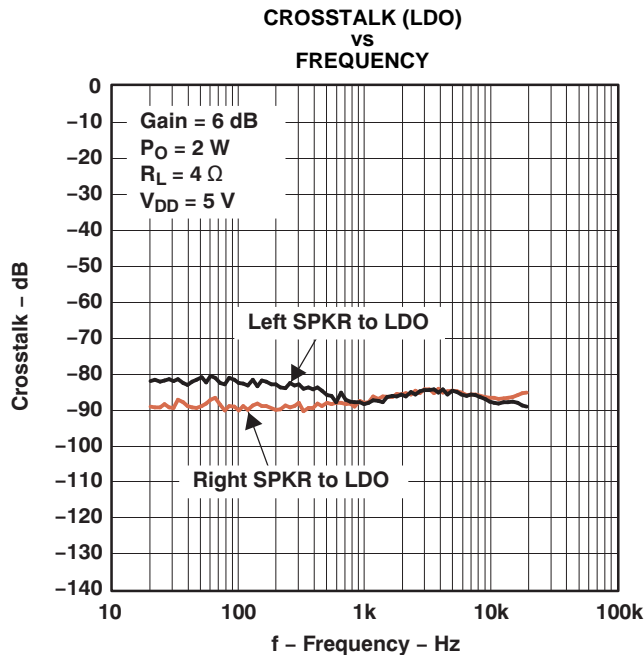

Figure 11.

G011

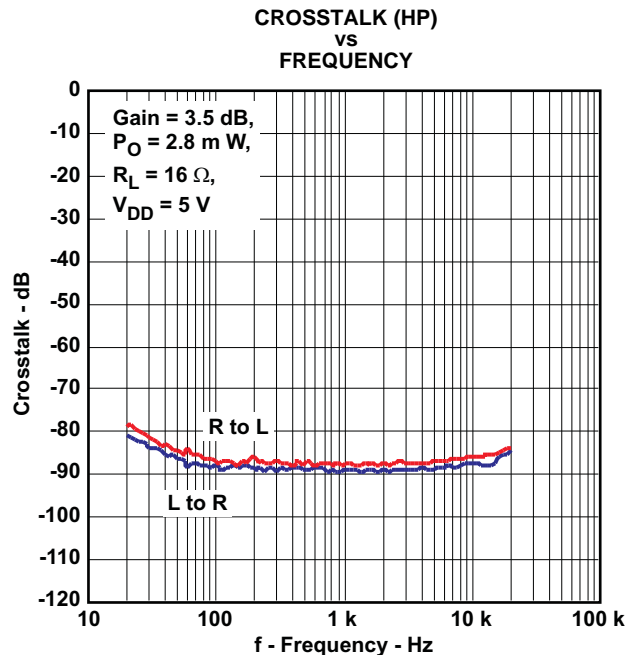

Figure 12.

TYPICAL CHARACTERISTICS (continued)

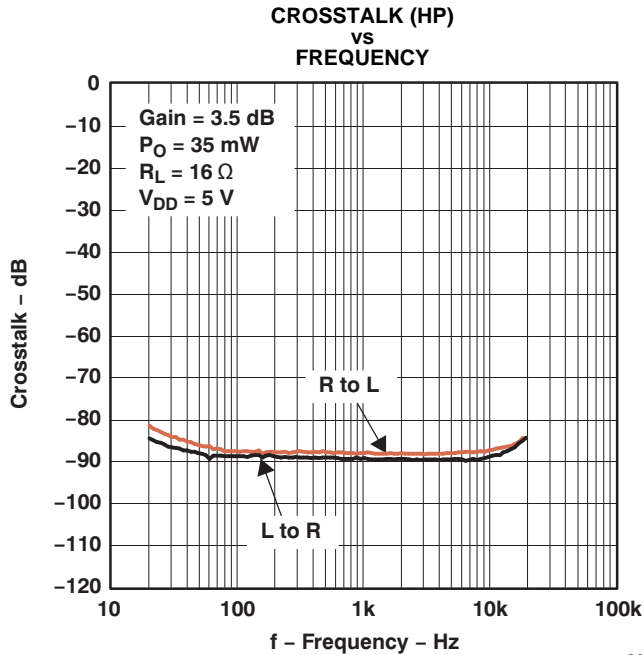

Figure 13.

G012

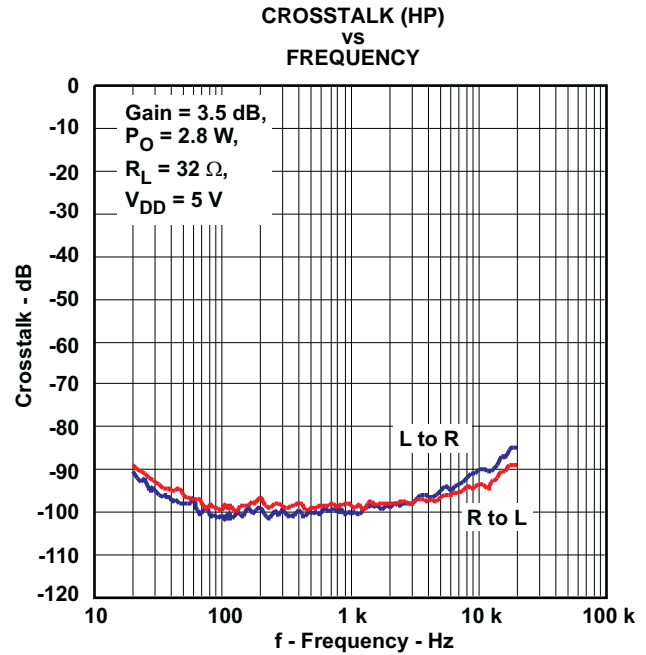

Figure 14.

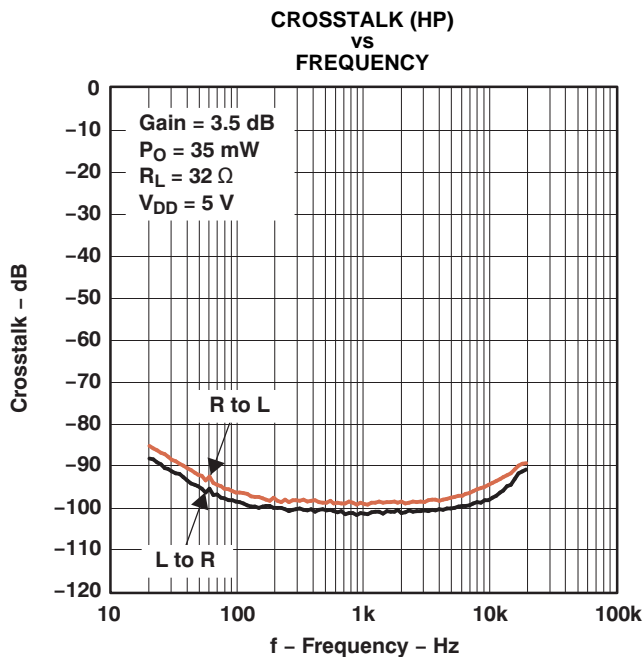

Figure 15.

G013

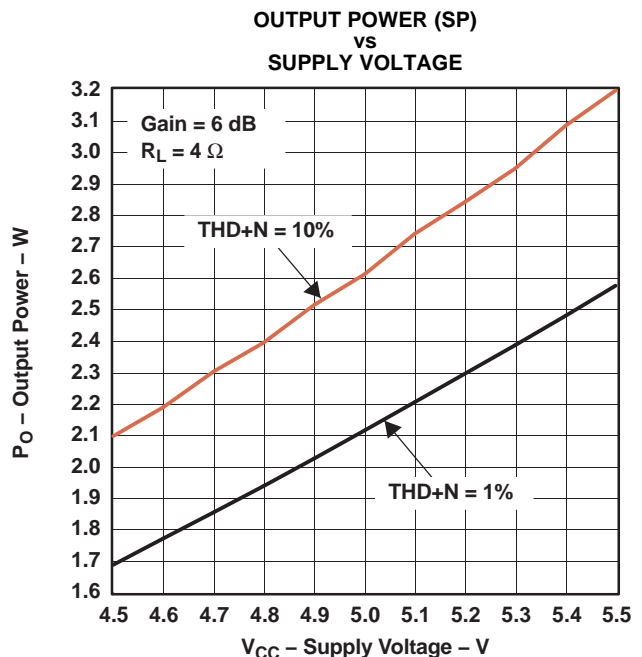

Figure 16.

G014

TYPICAL CHARACTERISTICS (continued)

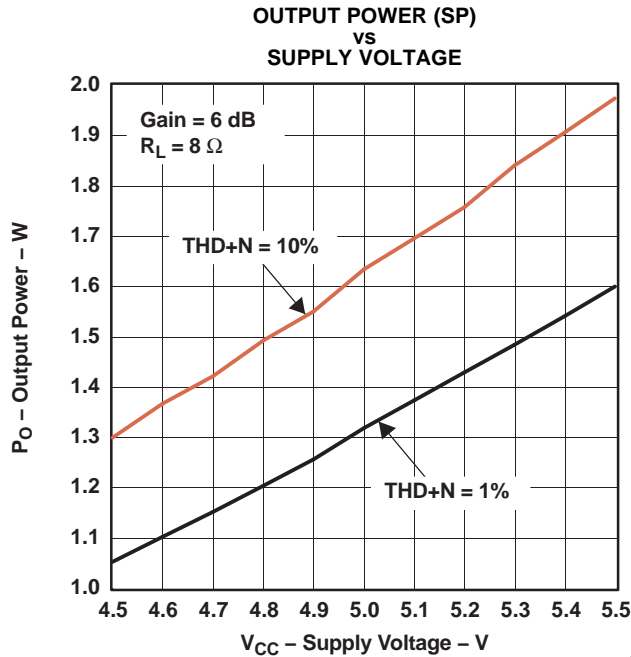

Figure 17.

G015

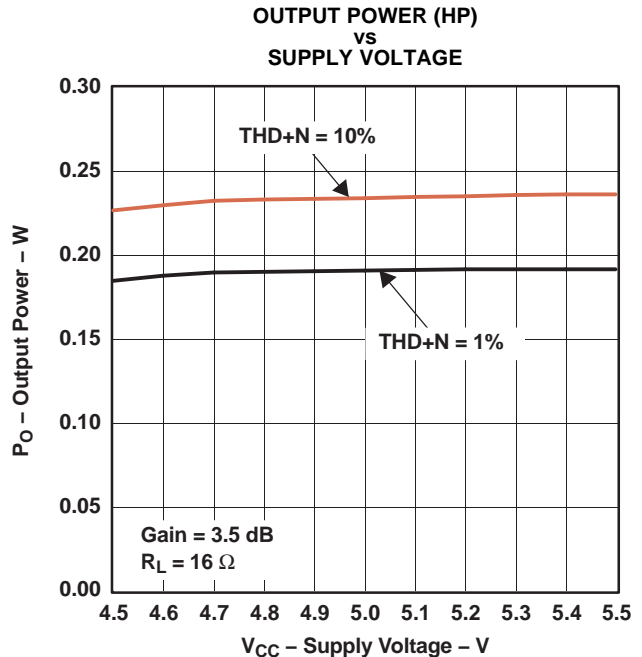

Figure 18.

G016

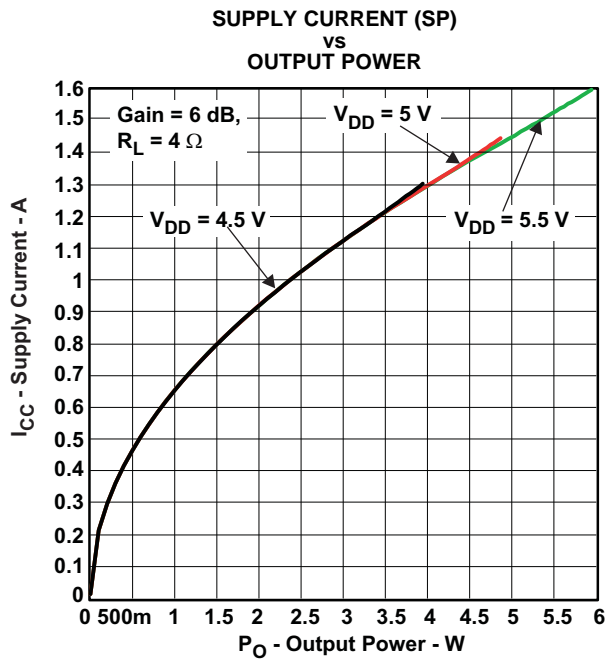

Figure 19.

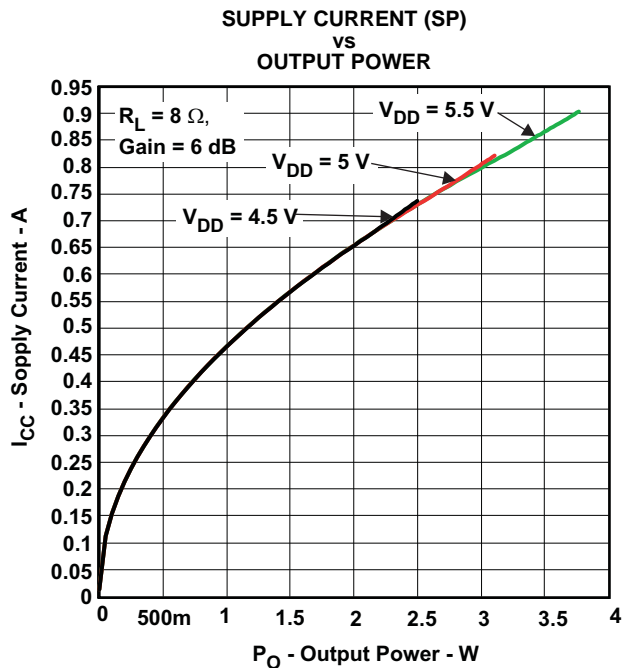

Figure 20.

TYPICAL CHARACTERISTICS (continued)

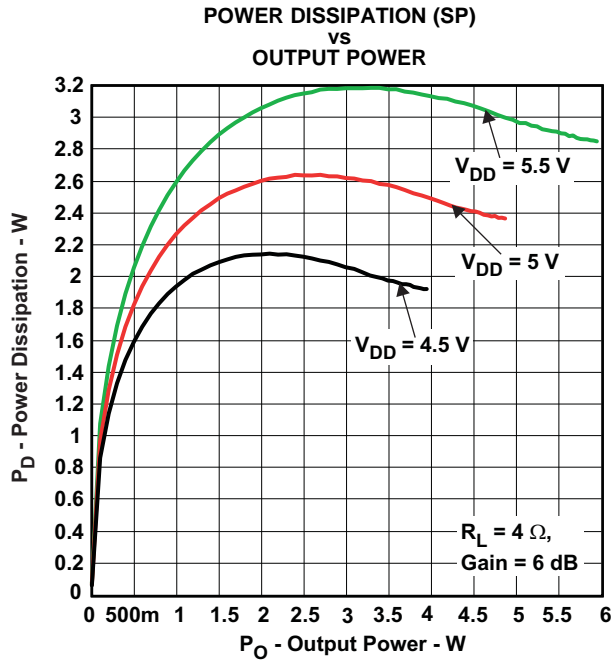

Figure 21.

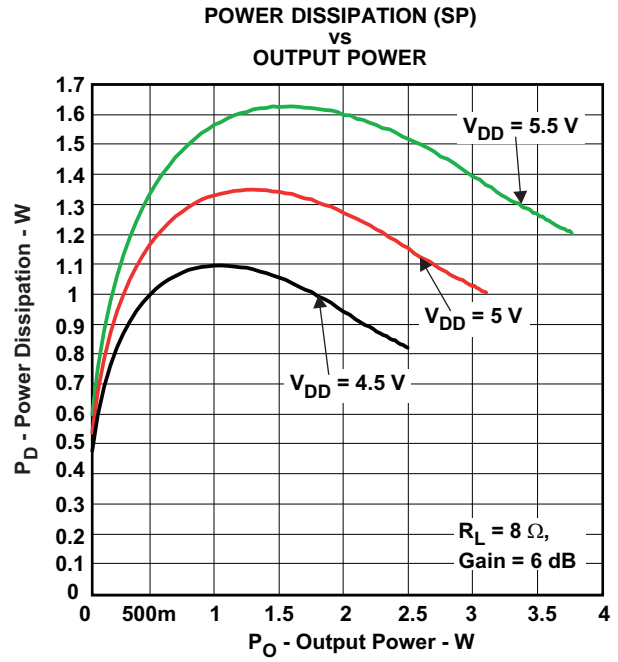

Figure 22.

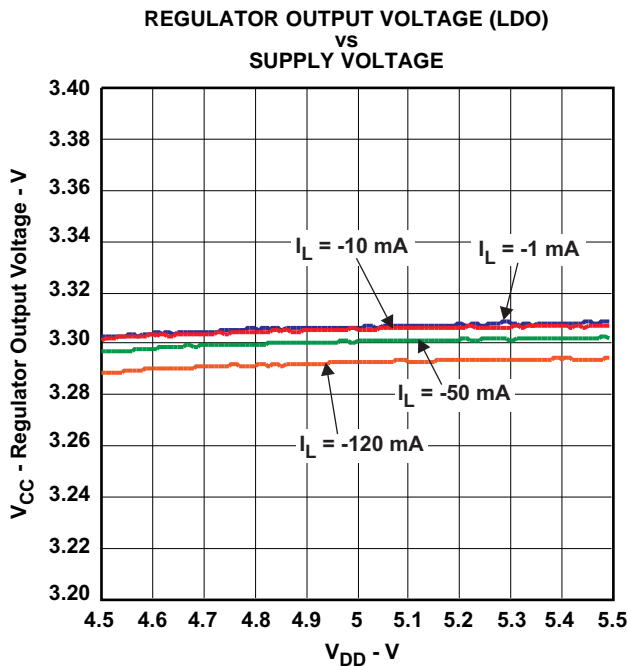

Figure 23.

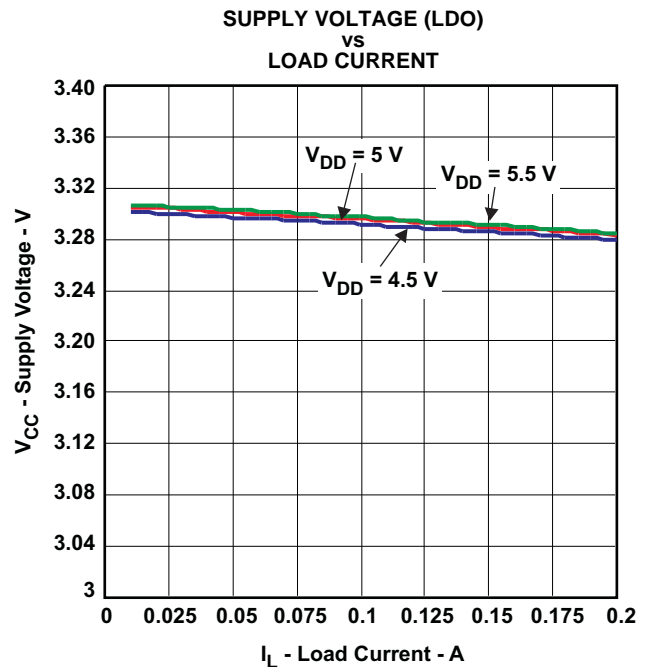

Figure 24.

TYPICAL CHARACTERISTICS (continued)

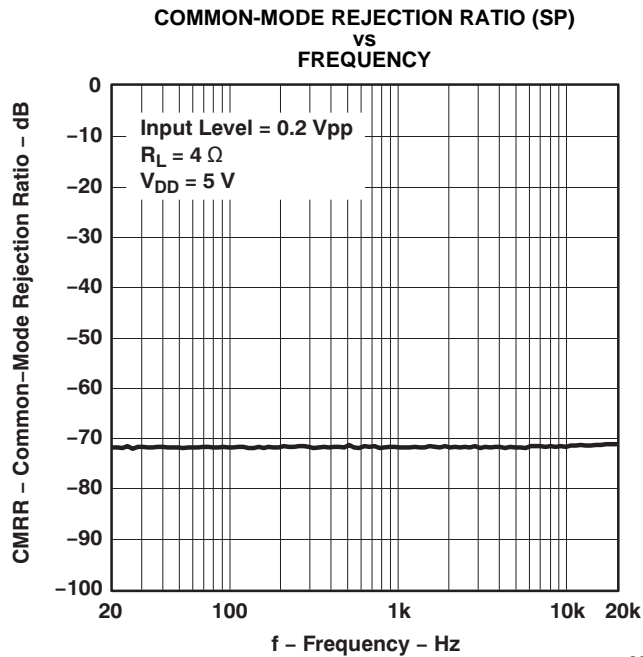

Figure 25.

G024

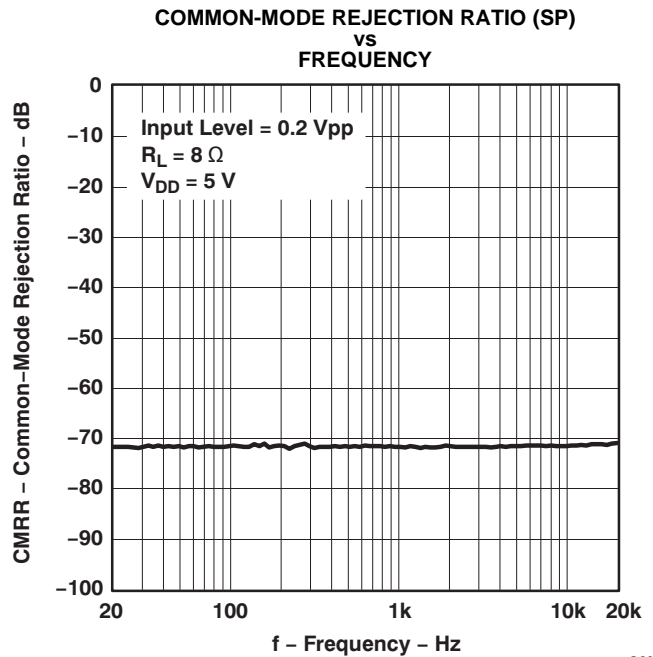

Figure 26.

G025

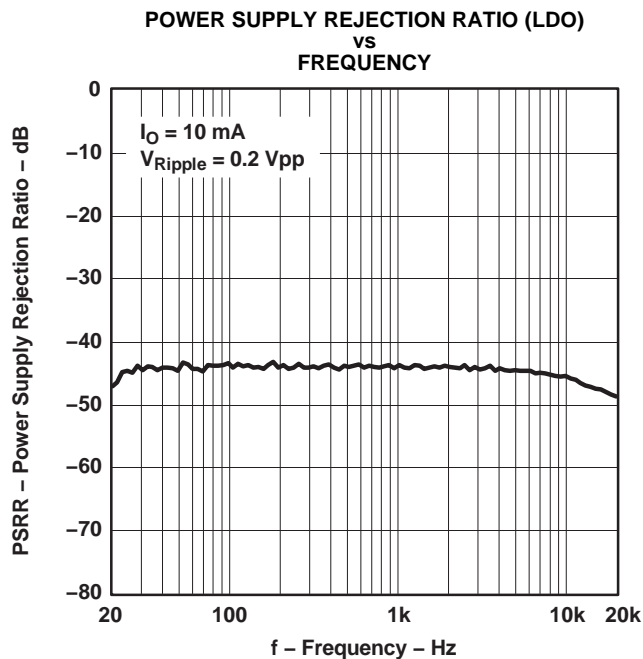

Figure 27.

G026

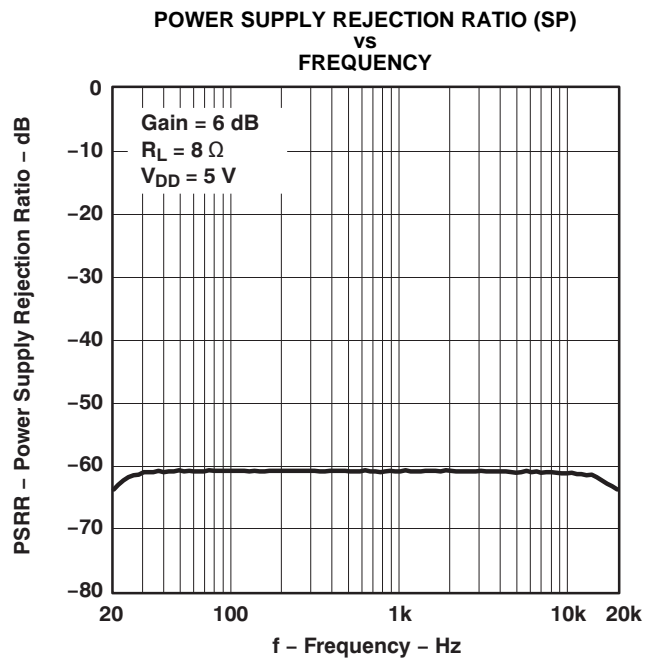

Figure 28.

G027

TYPICAL CHARACTERISTICS (continued)

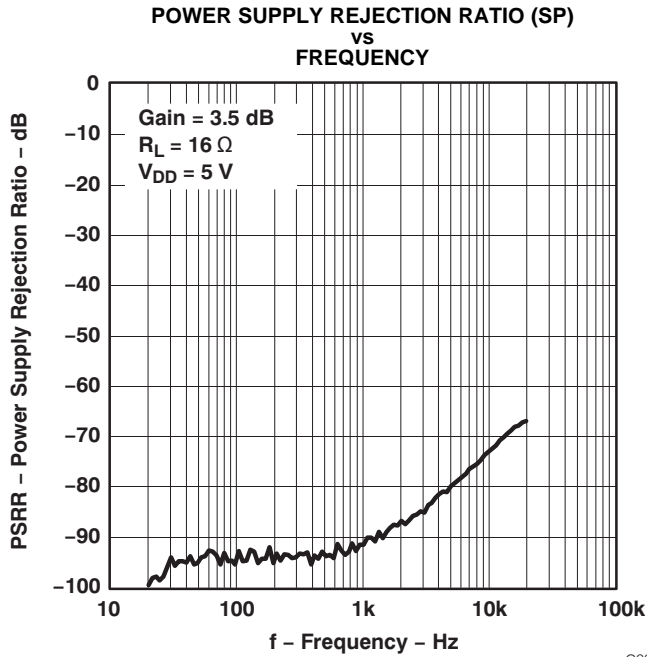

Figure 29.

G028

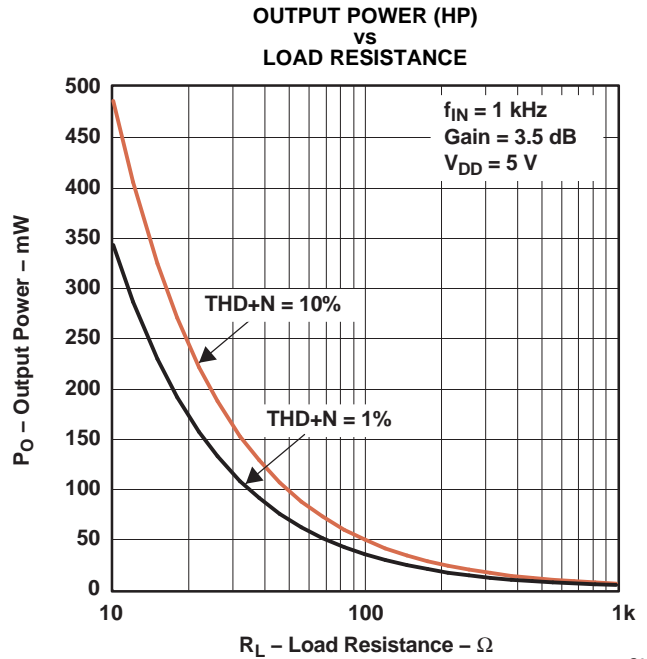

Figure 30.

G029

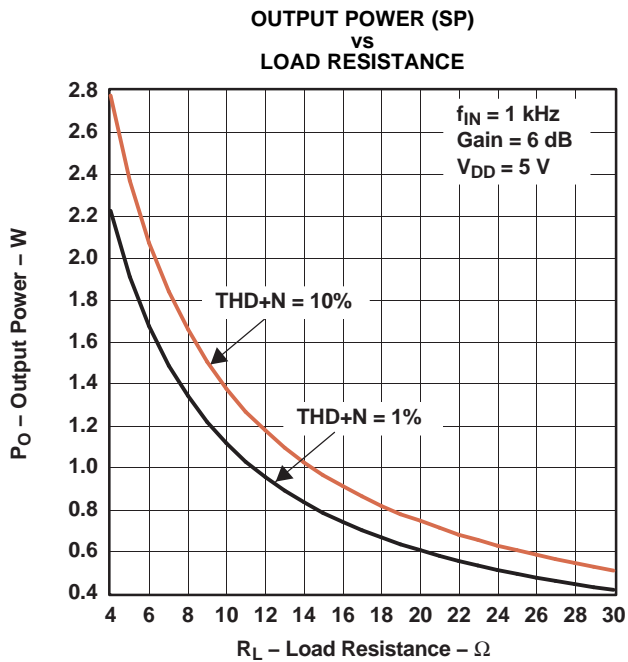

Figure 31.

G030

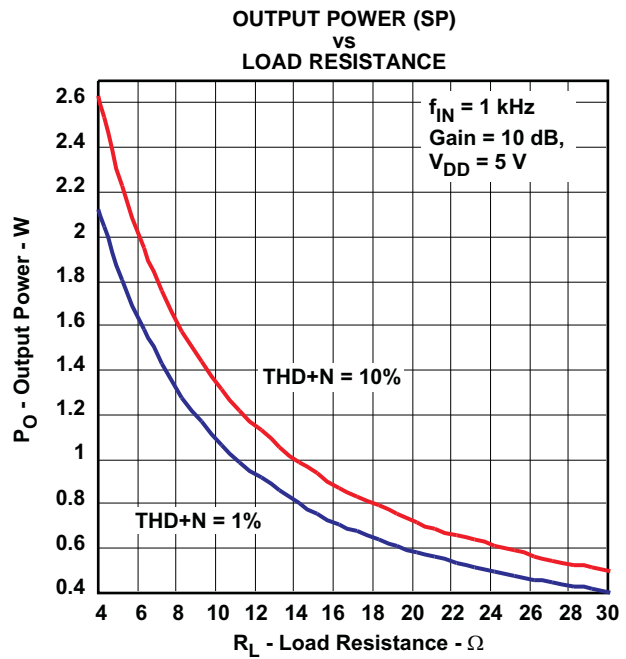

Figure 32.

TYPICAL CHARACTERISTICS (continued)

SPEAKER SHUTDOWN - 8 Ω - 10 dB

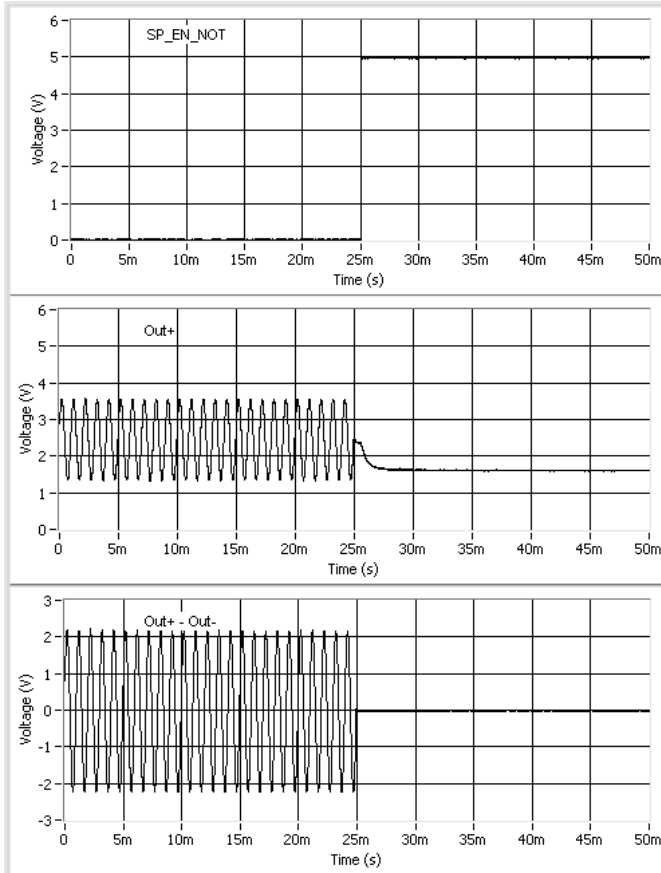

Figure 33.

SPEAKER STARTUP - 8 Ω - 10 dB

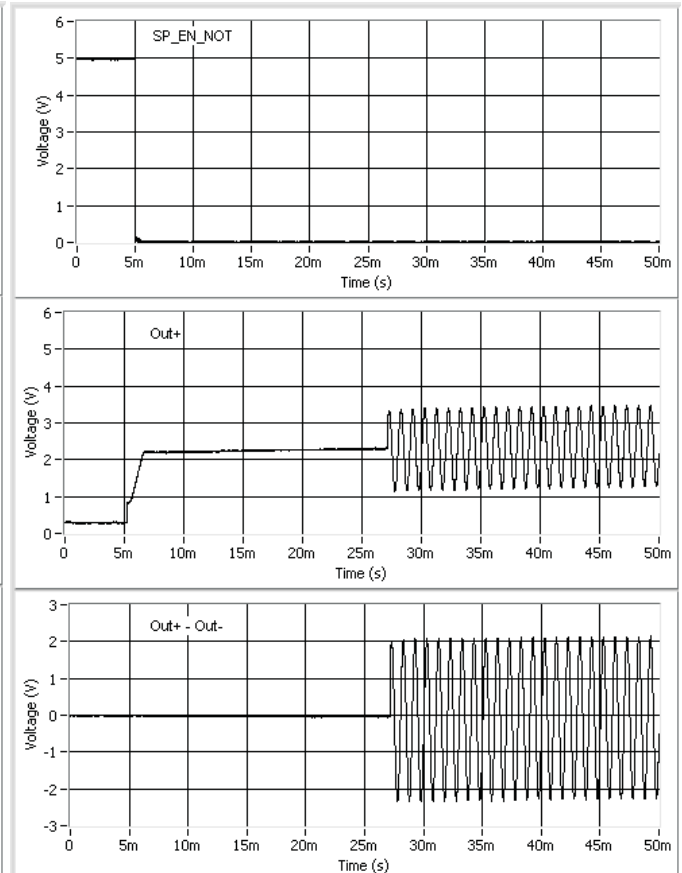

Figure 34.

LDO SHUTDOWN - 120 mA

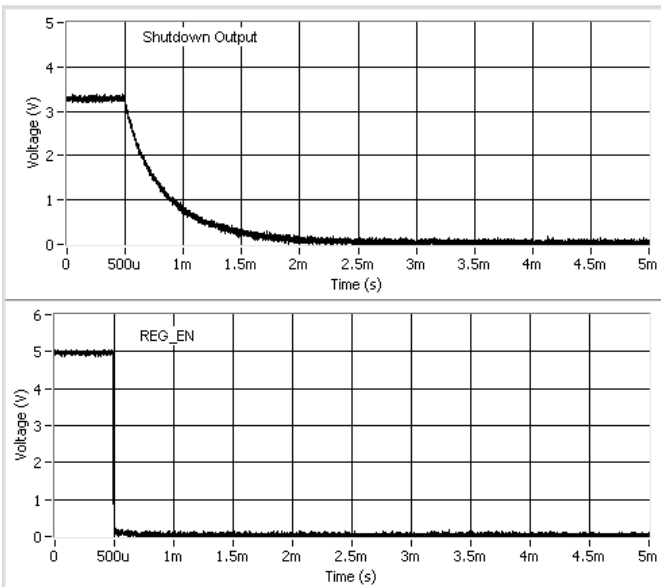

Figure 35.

LDO STARTUP - 120 mA

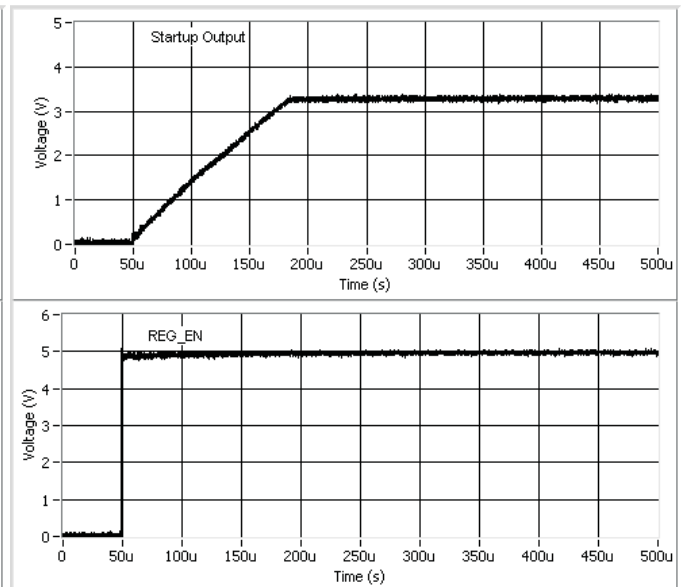

Figure 36.

TYPICAL CHARACTERISTICS (continued)

HP SHUTDOWN - 32 Ω

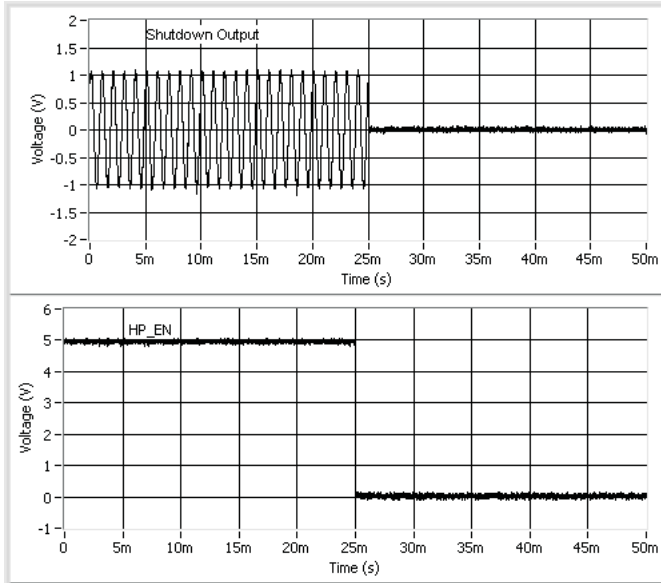

Figure 37.

HP STARTUP - 32 Ω

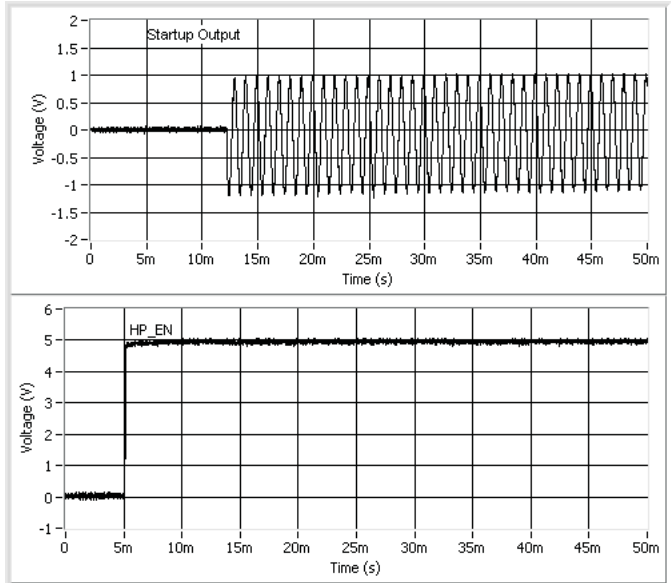

Figure 38.

APPLICATION INFORMATION

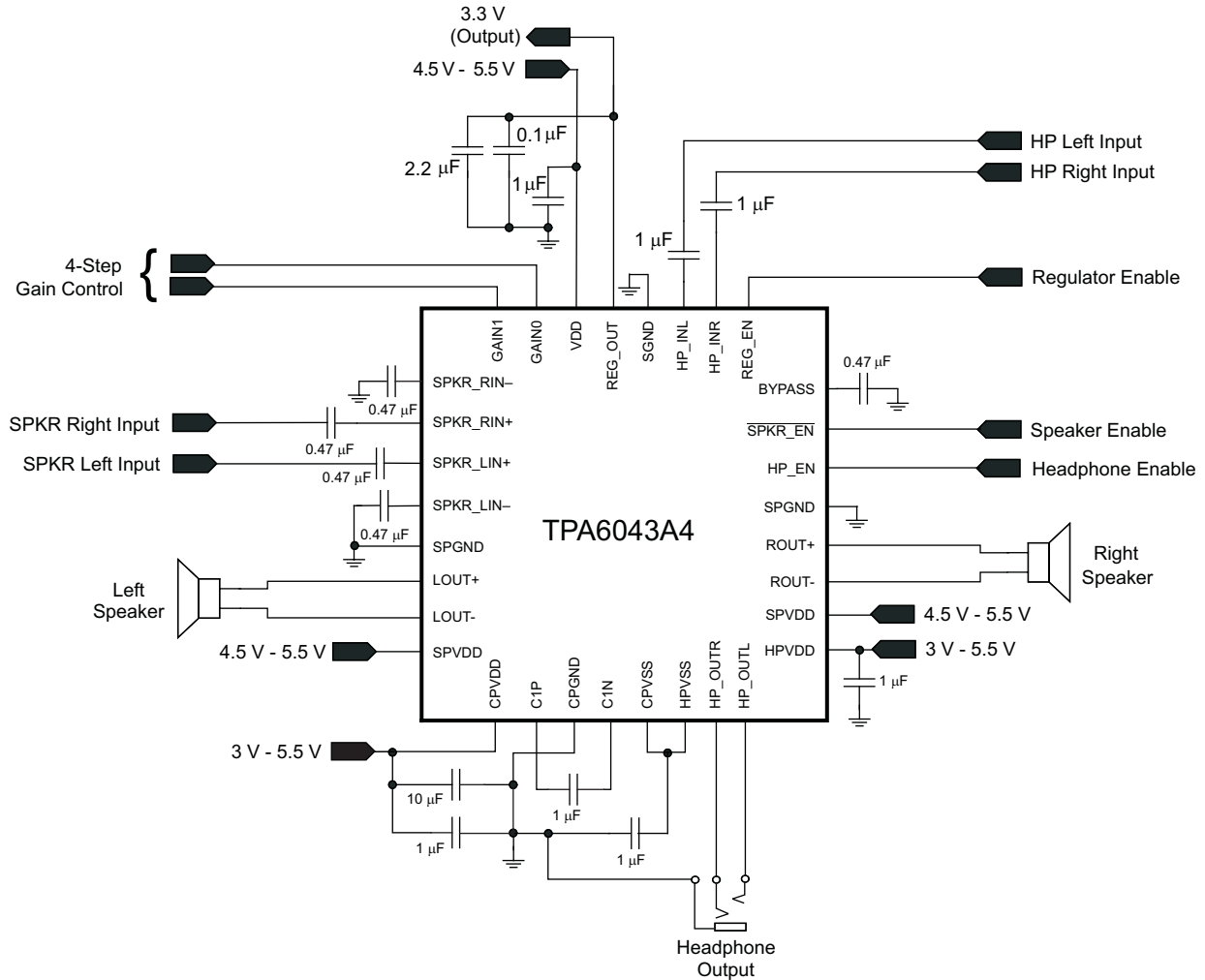

Figure 39. Single-Ended Input Application Circuit

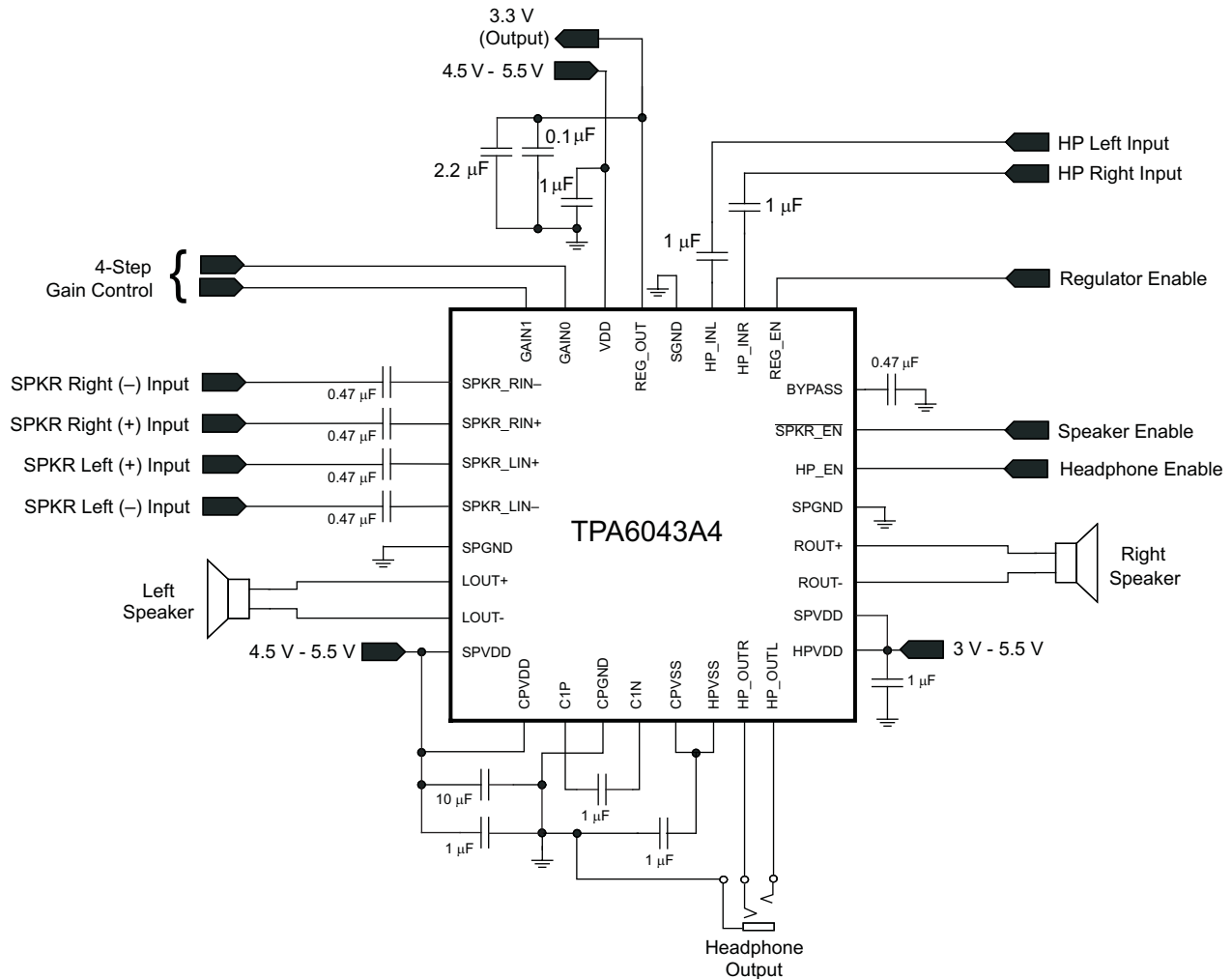

Figure 40. Differential Input Application Circuit

Power Enable Modes

The TPA6043A4 allows disable of any or all of the main circuit blocks when not in use in order to reduce operating power to an absolute minimum. The $\overline{\text{SPKR_EN}}$ control can be used to disable the speaker amplifier while the $\overline{\text{HP_EN}}$ can be used separately to turn off the headphone amplifier. The LDO also has an independent power control, $\overline{\text{REG_EN}}$. With all circuit blocks disabled, the supply current in shutdown mode is only 5 μA . See the General DC Electrical Characteristics for operating currents with each circuit block operating independently.

Speaker Amplifier Description

The speaker amplifier is capable of driving 2 W/ch of continuous RMS power into a 4- Ω load at 5 V. An internal 4-step control allows variation of the gain from 6 dB to 21.6 dB.

Fully Differential Amplifier

The TPA6043A4 speaker amplifier is a fully differential amplifier with differential inputs and outputs. The fully differential architecture consist of a differential amplifier and a common mode amplifier. The differential amplifier ensures that the amplifier outputs a differential voltage that is equal to the differential input times the gain. The common-mode voltage at the output is biased around $V_{\text{DD}}/2$ regardless of the common-mode voltage at the input.

One of the primary advantages of the fully differential amplifier is improved RF immunity. GSM handsets save power by turning on and off the RF transmitter at a rate of 217 Hz. The transmitted signal is picked up on input and output traces. The fully differential amplifier cancels the signal and others of this type much better than typical audio amplifiers.

Gain Setting via GAIN0 and GAIN1 Inputs

The gain of the TPA6043A4 is set by two terminals, GAIN0 and GAIN1. The gains listed in Table 1 are realized by changing the taps on the input resistors and feedback resistors inside the amplifier. This causes the input impedance (Z_i) to vary as a function of the gain setting.

Gain Setting

| GAIN1 | GAIN0 | AMPLIFIER GAIN (dB) | INPUT IMPEDANCE (k Ω) |
|-------|-------|---------------------|-------------------------------|
| | | TYPICAL | TYPICAL |
| 0 | 0 | 6 | 108 |
| 0 | 1 | 10 | 78 |
| 1 | 0 | 15.6 | 46 |
| 1 | 1 | 21.6 | 25 |

Input Capacitor, C_i

The input capacitor allows the amplifier to bias the input signal to the proper dc level for proper operation. In this case, the input capacitor, C_i , and the input impedance of the amplifier, R_i , form a high-pass filter with the corner frequency determined in Equation 1. Figure 41 shows how the input capacitor and the input resistor within the amplifier interact.

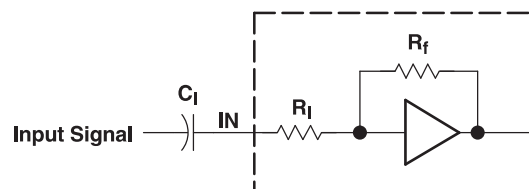
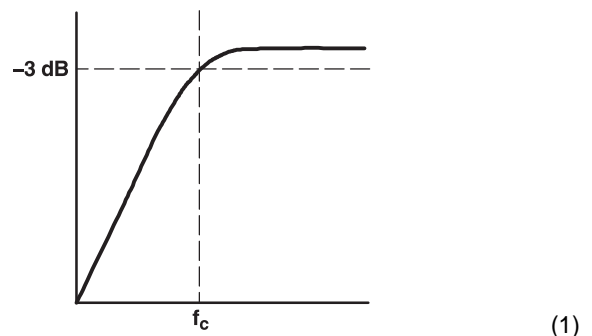

Figure 41. Input Resistor and Input Capacitor

$$f_{c(\text{highpass})} = \frac{1}{2\pi R_i C_i} \quad (1)$$



The value of C_i is important to consider as it directly affects the low-frequency, or bass, performance of the circuit. Furthermore, the input impedance changes with a change in volume. The higher the volume, the lower the input impedance is. To determine the appropriate capacitor value, reconfigure Equation 1 into Equation 2. The value of the input resistor, R_i , can be determined from Equation 2.

$$C_i = \frac{1}{2\pi R_i f_c} \quad (2)$$

Low-leakage tantalum or ceramic capacitors are recommended. When polarized capacitors are used, the positive side of the capacitor should face the amplifier input in most applications as the dc level there is held at $V_{CC}/2$, which is likely higher than the source dc level. Note that it is important to confirm the capacitor polarity in each specific application. Recommended capacitor values are between 0.1 μF and 1 μF .

Windows Vista™ Premium Mode Specifications

| Device Type | Requirement | Windows Premium Mobile Vista Specifications | TPA6043A4 Typical Performance |
|--|-----------------------------------|---|-------------------------------|
| Analog Speaker Output Jack ($R_L = 8\Omega$, FS = 0.707 Vrms) | THD+N | ≤ -65 dB FS [20 Hz, 20 kHz] | -74 dB FS [20 Hz, 20 kHz] |
| | Dynamic Range with Signal Present | ≤ -80 dB FS A-Weight | -89 dB FS A-Weight |
| | Line Output Crosstalk | ≤ -60 dB [20 Hz, 20 kHz] | -100 dB [20 Hz, 20 kHz] |
| Analog Headphone Out Jack ($R_L = 32\Omega$, FS = 0.300 Vrms) | THD+N | ≤ -45 dB FS [20 Hz, 20 kHz] | -81 dB FS [20 Hz, 20 kHz] |
| | Dynamic Range with Signal Present | ≤ -80 dB FS A-Weight | -100 dB FS A-Weight |
| | Headphone Output Crosstalk | ≤ -60 dB [20 Hz, 20 kHz] | -82 dB [20 Hz, 20 kHz] |

Bridge-Tied Load Versus Single-Ended Mode

Figure 42 shows a Class-AB audio power amplifier (APA) in a bridge-tied-load (BTL) configuration. The TPA6043A4 speaker amplifier consists of two Class-AB differential amplifiers per channel driving the positive and negative terminals of the load. Specifically, differential drive means that as one side of the amplifier (the positive terminal, for example) is slewing up, the other side is slewing down, and vice versa. This doubles the voltage swing across the load as opposed to a ground-referenced load, or a single-ended load. Power is proportional to the square of the voltage. Plugging $2x$ $V_{O(PP)}$ into the power equation yields $4x$ the output power from the same supply rail and load impedance as would have been obtained with a ground-referenced load (see Equation 3).

$$V_{(RMS)} = \frac{V_{O(PP)}}{2\sqrt{2}}$$

$$Power = \frac{V_{(RMS)}^2}{R_L}$$

(3)

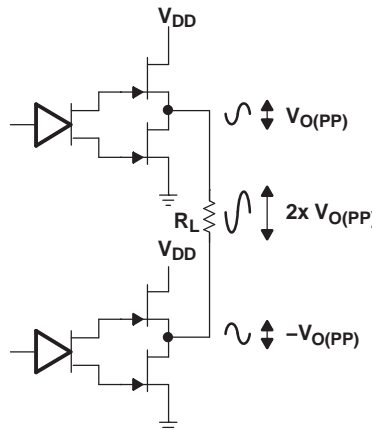

Figure 42. Differential Output Configuration

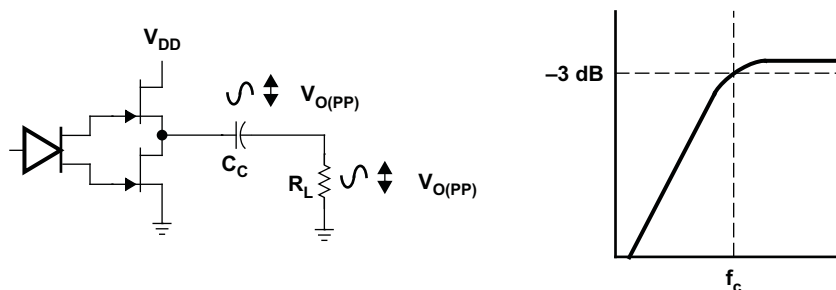

Figure 43. Single-Ended Configuration and Frequency Response

Bridge-tying the outputs in a typical computer audio, LCD TV, or multimedia LCD monitor application drastically increases output power. For example, if an amplifier in a single-ended configuration was capable of outputting a maximum of 250 mW for a given load with a supply voltage of 12 V, then that same amplifier would be able to output 1 W of power in a BTL configuration with the same supply voltage and load. In addition to the increase in output power, the BTL configuration does not suffer from the same low-frequency issues that plague the single-ended configuration. In a BTL configuration, there is no need for an output capacitor to block dc, so no unwanted filtering occurs. In addition, the BTL configuration saves money and space, as the dc-blocking capacitors needed for single-ended operation are large and expensive. For example, with an 8-Ω load in SE operation, the user needs a 1000-μF capacitor to obtain a cutoff frequency below 20 Hz. This capacitor is expensive and large.

Headphone Amplifier Description

The headphone amplifier has a fixed gain of -1.5 V/V. It uses single-ended (SE) inputs. The DirectPath™ amplifier architecture operates from a single supply but makes use of an internal charge pump to provide a negative voltage rail. Combining the user-provided positive rail and the negative rail generated by the IC, the device operates in what is effectively a split supply mode. The output voltages are now centered at zero volts with the capability to swing to the positive rail or negative rail. The DirectPath™ amplifier requires no output dc blocking capacitors and does not place any voltage on the sleeve. The block diagram and waveform of [Figure 44](#) illustrate the ground-referenced headphone architecture. This is the architecture of the TPA6043A4.

Single-supply headphone amplifiers typically require dc-blocking capacitors. The capacitors are required because most headphone amplifiers have a dc bias on the outputs pin. If the dc bias is not removed, the output signal is severely clipped, and large amounts of dc current rush through the headphones, potentially damaging them. The left-side drawing in [Figure 44](#) illustrates the conventional headphone amplifier connection to the headphone jack and output signal.

DC blocking capacitors are often large in value. The headphone speakers (typical resistive values of 16 Ω or 32 Ω) combine with the dc blocking capacitors to form a high-pass filter. [Equation 4](#) shows the relationship between the load impedance (R_L), the capacitor (C_O), and the cutoff frequency (f_c).

$$f_c = \frac{1}{2\pi R_L C_O} \quad (4)$$

C_O can be determined using [Equation 5](#), where the load impedance and the cutoff frequency are known.

$$C_O = \frac{1}{2\pi R_L f_c} \quad (5)$$

If f_c is low, the capacitor must then have a large value because the load resistance is small. Large capacitance values require large package sizes. Large package sizes consume PCB area, stand high above the PCB, increase cost of assembly, and can reduce the fidelity of the audio output signal.

Two different headphone amplifier applications are available that allow for the removal of the output dc blocking capacitors. The capacitor-less amplifier architecture is implemented in the same manner as the conventional amplifier with the exception of the headphone jack shield pin. This amplifier provides a reference voltage, which is connected to the headphone jack shield pin. This is the voltage on which the audio output signals are centered. This voltage reference is half of the amplifier power supply to allow symmetrical swing of the output voltages. Do not connect the shield to any GND reference, or large currents will result. The scenario can happen if, for example, an accessory other than a floating GND headphone is plugged into the headphone connector. See the second block diagram and waveform in [Figure 44](#).

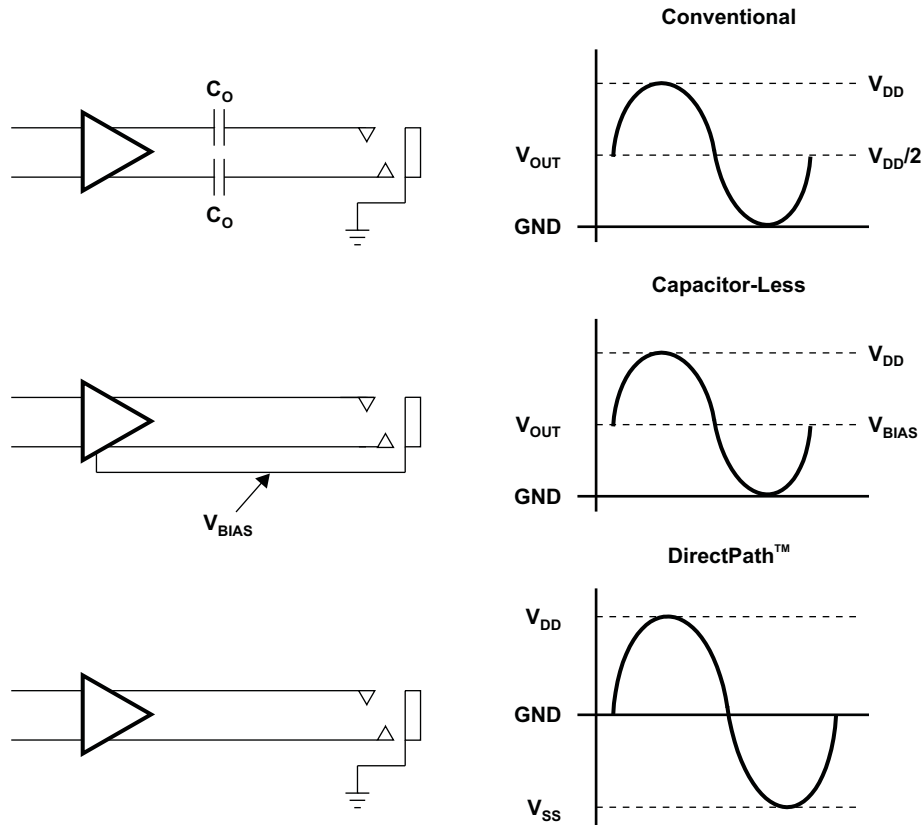

Figure 44. Amplifier Applications

Input-Blocking Capacitors

DC input-blocking capacitors block the dc portion of the audio source and allow the inputs to properly bias. Maximum performance is achieved when the inputs of the TPA6043A4 are properly biased. Performance issues such as pop are optimized with proper input capacitors.

The dc input-blocking capacitors can be removed, provided the inputs are connected differentially and within the input common-mode range of the amplifier, the audio signal does not exceed ± 3 V, and pop performance is sufficient.

C_{IN} is a theoretical capacitor used for mathematical calculations only. Its value is the series combination of the dc input-blocking capacitors, $C_{(DCINPUT-BLOCKING)}$. Use Equation 6 to determine the value of $C_{(DCINPUT-BLOCKING)}$. For example, if C_{IN} is equal to 0.22 μ F, then $C_{(DCINPUT-BLOCKING)}$ is equal to about 0.47 μ F.

$$C_{IN} = \frac{1}{2} C_{(DCINPUT-BLOCKING)} \tag{6}$$

The two $C_{(DCINPUT-BLOCKING)}$ capacitors form a high-pass filter with the input impedance of the TPA6043A4. Use Equation 6 to calculate C_{IN} , then calculate the cutoff frequency using C_{IN} and the differential input impedance of the TPA6043A4, R_{IN} , using Equation 7. Note that the differential input impedance changes with gain. See Figure 40 for input impedance values. The frequency and/or capacitance can be determined when one of the two values are given.

$$f_{C_{IN}} = \frac{1}{2\pi R_{IN} C_{IN}} \quad \text{or} \quad C_{IN} = \frac{1}{2\pi f_{C_{IN}} R_{IN}} \quad (7)$$

If a high-pass filter with a -3-dB point of no more than 20 Hz is desired over all gain settings, the minimum impedance would be used in the Equation 7. The minimum input impedance for TPA6043A4 is 20 kΩ. The capacitor value by Equation 7 would be 0.399 μF. However, this is C_{IN} , and the desired value is for $C_{(DC\text{INPUT-BLOCKING})}$. Multiplying C_{IN} by 2 yields 0.80 μF, which is close to the standard capacitor value of 1 μF. Place 1-μF capacitors at each input terminal of the TPA6043A4 to complete the filter.

Charge Pump Flying Capacitor and CPVSS Capacitor

The charge pump flying capacitor serves to transfer charge during the generation of the negative supply voltage. The CPVSS capacitor must be at least equal to the flying capacitor in order to allow maximum charge transfer. Low ESR capacitors are an ideal selection, and a value of 1 μF is typical.

Decoupling Capacitors

The TPA6043A4 is a DirectPath™ headphone amplifier that requires adequate power supply decoupling to ensure that the noise and total harmonic distortion (THD) are as low as possible. To filter high-frequency transients, spikes, and digital hash on the power line, use good low equivalent-series-resistance (ESR) ceramic capacitors, typically 1 μF. Find the smallest package possible, and place as close as possible to the device V_{DD} lead. Placing the decoupling capacitors close to the TPA6043A4 is important for the performance of the amplifier. Use a 10 μF or greater capacitor near the TPA6043A4 to filter lower frequency noise signals; however, the high PSRR of the TPA6043A4 makes the 10-μF capacitor unnecessary in most applications.

Midrail Bypass Capacitor, C_{BYPASS}

The midrail bypass capacitor, $C_{(BYPASS)}$, has several important functions. During start-up or recovery from shutdown mode, C_{BYPASS} determines the rate at which the amplifier starts up. A 1-μF capacitor yields a start-up time of approximately 30 ms. C_{BYPASS} also reduces the noise coupled into the output signal by the power supply. This improves the power supply ripple rejection (PSRR) of the amplifier. Ceramic or polyester capacitors with low ESR and values in the range of 0.47 μF to 1 μF are recommended.

LOW DROPOUT REGULATOR (LDO) DESCRIPTION

The TPA6043A4 contains a 3.3-V output low dropout regulator (LDO) capable of providing a maximum of 120 mA with a drop of less than 150 mV from the 5-V supply. This can be used to power an external CODEC. A 10-μF decoupling capacitor is recommended at the output of the LDO, as well as 0.1-μF capacitor to filter high-frequency noise from the supply line.

LAYOUT RECOMMENDATIONS

Solder the exposed thermal pad (metal pad on the bottom of the part) on the TPA6043A4 QFN package to a pad on the PCB.

It is important to keep the TPA6043A4 external components close to the body of the amplifier to limit noise pickup. One should lay out the differential input leads symmetrical and close together to take advantage of the inherent common mode rejection of the TPA6043A4. The layout of the TPA6043A4 evaluation module (EVM) is a good example of component placement, and the layout files are available at www.ti.com.

PACKAGING INFORMATION

| Orderable Device | Status ⁽¹⁾ | Package Type | Package Drawing | Pins | Package Qty | Eco Plan ⁽²⁾ | Lead/Ball Finish | MSL Peak Temp ⁽³⁾ |
|------------------|-----------------------|--------------|-----------------|------|-------------|-------------------------|------------------|------------------------------|
| TPA6043A4RHBR | ACTIVE | QFN | RHB | 32 | 3000 | Green (RoHS & no Sb/Br) | CU NIPDAU | Level-3-260C-168 HR |
| TPA6043A4RHBRG4 | ACTIVE | QFN | RHB | 32 | 3000 | Green (RoHS & no Sb/Br) | CU NIPDAU | Level-3-260C-168 HR |

⁽¹⁾ The marketing status values are defined as follows:

ACTIVE: Product device recommended for new designs.

LIFEBUY: TI has announced that the device will be discontinued, and a lifetime-buy period is in effect.

NRND: Not recommended for new designs. Device is in production to support existing customers, but TI does not recommend using this part in a new design.

PREVIEW: Device has been announced but is not in production. Samples may or may not be available.

OBSOLETE: TI has discontinued the production of the device.

⁽²⁾ Eco Plan - The planned eco-friendly classification: Pb-Free (RoHS), Pb-Free (RoHS Exempt), or Green (RoHS & no Sb/Br) - please check <http://www.ti.com/productcontent> for the latest availability information and additional product content details.

TBD: The Pb-Free/Green conversion plan has not been defined.

Pb-Free (RoHS): TI's terms "Lead-Free" or "Pb-Free" mean semiconductor products that are compatible with the current RoHS requirements for all 6 substances, including the requirement that lead not exceed 0.1% by weight in homogeneous materials. Where designed to be soldered at high temperatures, TI Pb-Free products are suitable for use in specified lead-free processes.

Pb-Free (RoHS Exempt): This component has a RoHS exemption for either 1) lead-based flip-chip solder bumps used between the die and package, or 2) lead-based die adhesive used between the die and leadframe. The component is otherwise considered Pb-Free (RoHS compatible) as defined above.

Green (RoHS & no Sb/Br): TI defines "Green" to mean Pb-Free (RoHS compatible), and free of Bromine (Br) and Antimony (Sb) based flame retardants (Br or Sb do not exceed 0.1% by weight in homogeneous material)

⁽³⁾ MSL, Peak Temp. -- The Moisture Sensitivity Level rating according to the JEDEC industry standard classifications, and peak solder temperature.

Important Information and Disclaimer:The information provided on this page represents TI's knowledge and belief as of the date that it is provided. TI bases its knowledge and belief on information provided by third parties, and makes no representation or warranty as to the accuracy of such information. Efforts are underway to better integrate information from third parties. TI has taken and continues to take reasonable steps to provide representative and accurate information but may not have conducted destructive testing or chemical analysis on incoming materials and chemicals. TI and TI suppliers consider certain information to be proprietary, and thus CAS numbers and other limited information may not be available for release.

In no event shall TI's liability arising out of such information exceed the total purchase price of the TI part(s) at issue in this document sold by TI to Customer on an annual basis.

TAPE AND REEL BOX INFORMATION

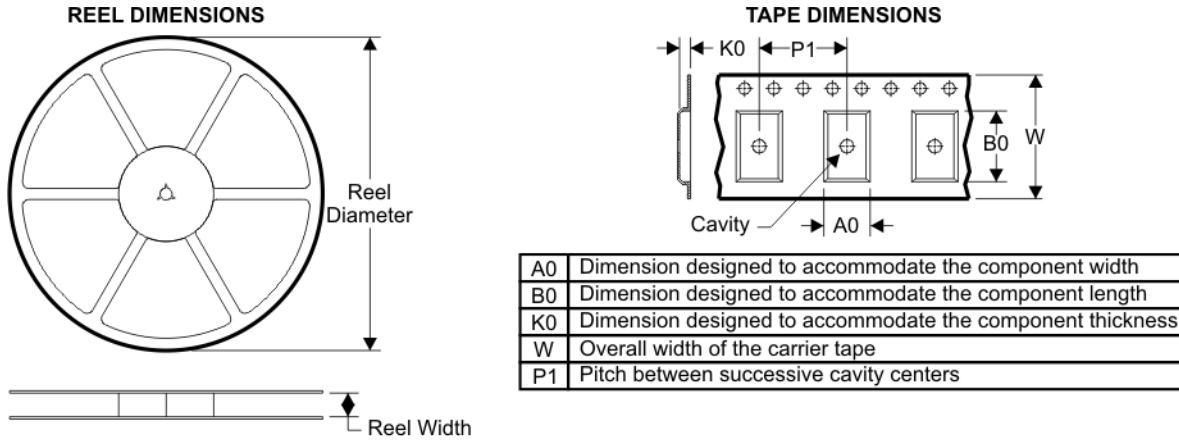

QUADRANT ASSIGNMENTS FOR PIN 1 ORIENTATION IN TAPE

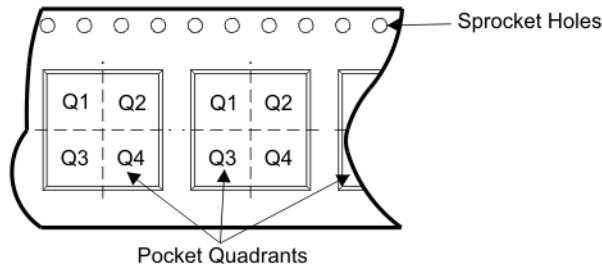

| Device | Package | Pins | Site | Reel Diameter (mm) | Reel Width (mm) | A0 (mm) | B0 (mm) | K0 (mm) | P1 (mm) | W (mm) | Pin1 Quadrant |
|---------------|---------|------|---------|--------------------|-----------------|---------|---------|---------|---------|--------|---------------|
| TPA6043A4RHBR | RHB | 32 | SITE 41 | 330 | 12 | 5.3 | 5.3 | 1.5 | 8 | 12 | Q2 |

TAPE AND REEL BOX DIMENSIONS

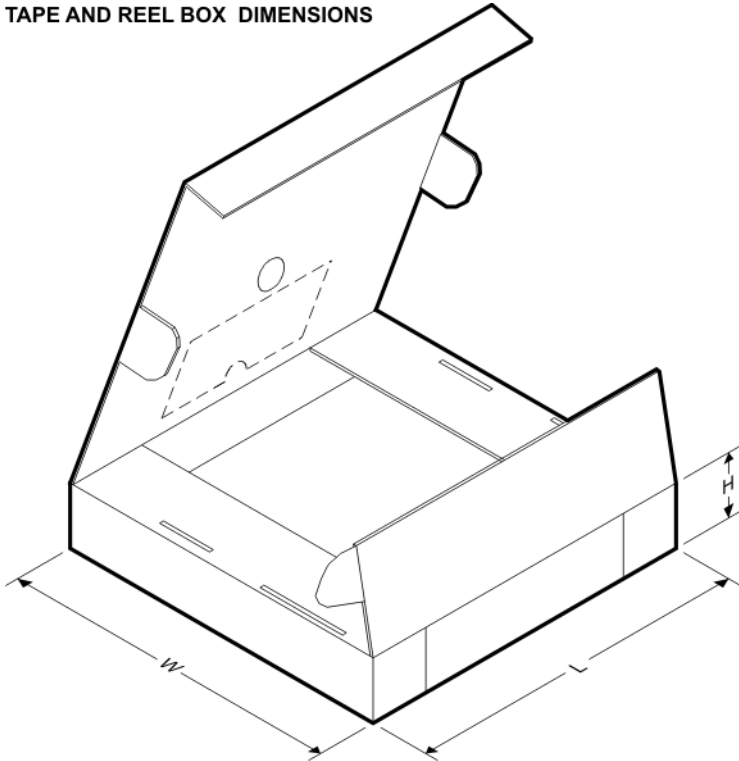

| Device | Package | Pins | Site | Length (mm) | Width (mm) | Height (mm) |
|---------------|---------|------|---------|-------------|------------|-------------|
| TPA6043A4RHBR | RHB | 32 | SITE 41 | 346.0 | 346.0 | 29.0 |

MECHANICAL DATA

RHB (S-PQFP-N32)

PLASTIC QUAD FLATPACK

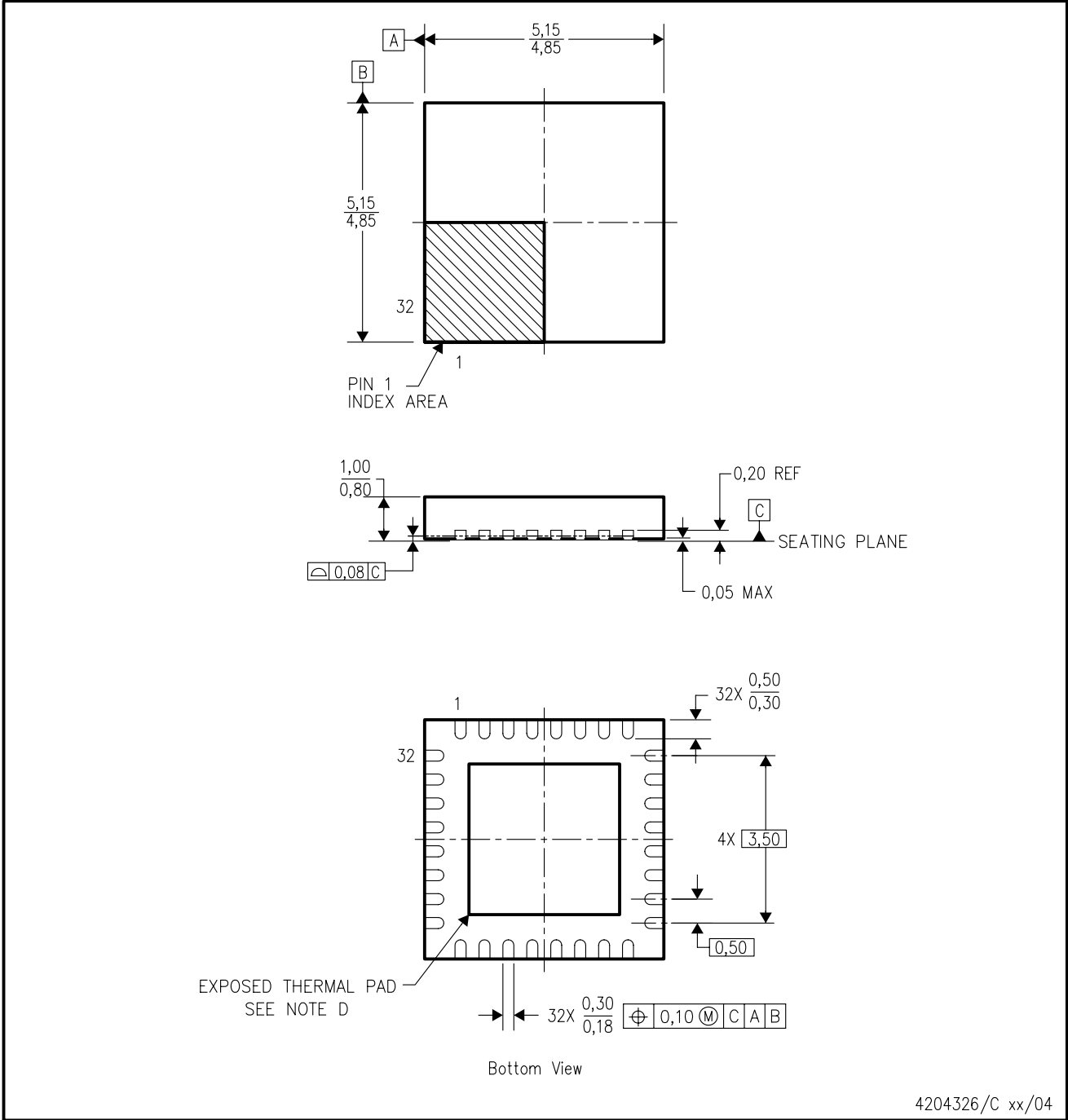

- NOTES:
- A. All linear dimensions are in millimeters.
 - B. This drawing is subject to change without notice.
 - C. QFN (Quad Flatpack No-Lead) Package configuration.
 - D. The Package thermal pad must be soldered to the board for thermal and mechanical performance. See product data sheet for details regarding the exposed thermal pad dimensions.
 - E. Falls within JEDEC MO-220.

THERMAL INFORMATION

This package incorporates an exposed thermal pad that is designed to be attached directly to an external heatsink. The thermal pad must be soldered directly to the printed circuit board (PCB). After soldering, the PCB can be used as a heatsink. In addition, through the use of thermal vias, the thermal pad can be attached directly to the appropriate copper plane shown in the electrical schematic for the device, or alternatively, can be attached to a special heatsink structure designed into the PCB. This design optimizes the heat transfer from the integrated circuit (IC).

For information on the Quad Flatpack No-Lead (QFN) package and its advantages, refer to Application Report, Quad Flatpack No-Lead Logic Packages, Texas Instruments Literature No. SCBA017. This document is available at www.ti.com.

The exposed thermal pad dimensions for this package are shown in the following illustration.

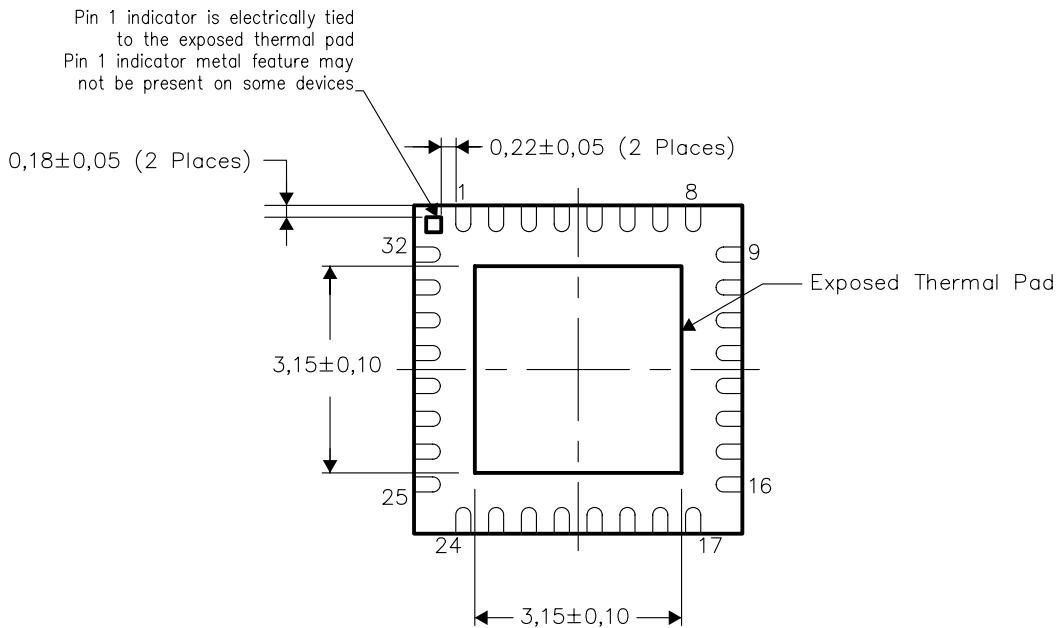

Bottom View

NOTE: All linear dimensions are in millimeters

Exposed Thermal Pad Dimensions

RHB (S-PQFP-N32)

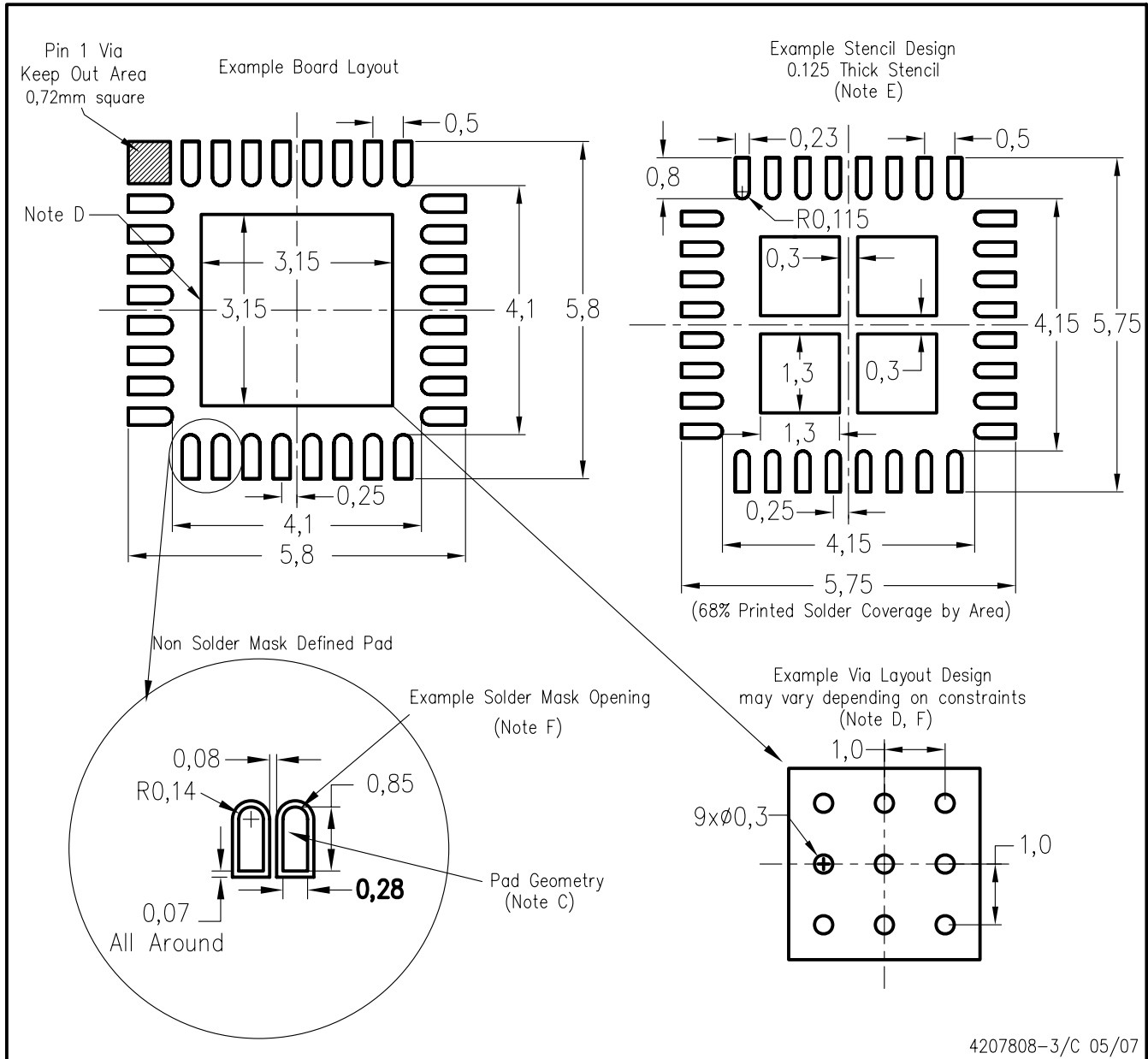

4207808-3/C 05/07

- NOTES:
- All linear dimensions are in millimeters.
 - This drawing is subject to change without notice.
 - Publication IPC-7351 is recommended for alternate designs.
 - This package is designed to be soldered to a thermal pad on the board. Refer to Application Note, Quad Flat-Pack Packages, Texas Instruments Literature No. SCBA017, SLUA271, and also the Product Data Sheets for specific thermal information, via requirements, and recommended board layout. These documents are available at www.ti.com <<http://www.ti.com>>.
 - Laser cutting apertures with trapezoidal walls and also rounding corners will offer better paste release. Customers should contact their board assembly site for stencil design recommendations. Refer to IPC 7525 for stencil design considerations.
 - Customers should contact their board fabrication site for recommended solder mask tolerances and via tenting recommendations for vias placed in the thermal pad.

IMPORTANT NOTICE

Texas Instruments Incorporated and its subsidiaries (TI) reserve the right to make corrections, modifications, enhancements, improvements, and other changes to its products and services at any time and to discontinue any product or service without notice. Customers should obtain the latest relevant information before placing orders and should verify that such information is current and complete. All products are sold subject to TI's terms and conditions of sale supplied at the time of order acknowledgment.

TI warrants performance of its hardware products to the specifications applicable at the time of sale in accordance with TI's standard warranty. Testing and other quality control techniques are used to the extent TI deems necessary to support this warranty. Except where mandated by government requirements, testing of all parameters of each product is not necessarily performed.

TI assumes no liability for applications assistance or customer product design. Customers are responsible for their products and applications using TI components. To minimize the risks associated with customer products and applications, customers should provide adequate design and operating safeguards.

TI does not warrant or represent that any license, either express or implied, is granted under any TI patent right, copyright, mask work right, or other TI intellectual property right relating to any combination, machine, or process in which TI products or services are used. Information published by TI regarding third-party products or services does not constitute a license from TI to use such products or services or a warranty or endorsement thereof. Use of such information may require a license from a third party under the patents or other intellectual property of the third party, or a license from TI under the patents or other intellectual property of TI.

Reproduction of TI information in TI data books or data sheets is permissible only if reproduction is without alteration and is accompanied by all associated warranties, conditions, limitations, and notices. Reproduction of this information with alteration is an unfair and deceptive business practice. TI is not responsible or liable for such altered documentation. Information of third parties may be subject to additional restrictions.

Resale of TI products or services with statements different from or beyond the parameters stated by TI for that product or service voids all express and any implied warranties for the associated TI product or service and is an unfair and deceptive business practice. TI is not responsible or liable for any such statements.

TI products are not authorized for use in safety-critical applications (such as life support) where a failure of the TI product would reasonably be expected to cause severe personal injury or death, unless officers of the parties have executed an agreement specifically governing such use. Buyers represent that they have all necessary expertise in the safety and regulatory ramifications of their applications, and acknowledge and agree that they are solely responsible for all legal, regulatory and safety-related requirements concerning their products and any use of TI products in such safety-critical applications, notwithstanding any applications-related information or support that may be provided by TI. Further, Buyers must fully indemnify TI and its representatives against any damages arising out of the use of TI products in such safety-critical applications.

TI products are neither designed nor intended for use in military/aerospace applications or environments unless the TI products are specifically designated by TI as military-grade or "enhanced plastic." Only products designated by TI as military-grade meet military specifications. Buyers acknowledge and agree that any such use of TI products which TI has not designated as military-grade is solely at the Buyer's risk, and that they are solely responsible for compliance with all legal and regulatory requirements in connection with such use.

TI products are neither designed nor intended for use in automotive applications or environments unless the specific TI products are designated by TI as compliant with ISO/TS 16949 requirements. Buyers acknowledge and agree that, if they use any non-designated products in automotive applications, TI will not be responsible for any failure to meet such requirements.

Following are URLs where you can obtain information on other Texas Instruments products and application solutions:

| Products | | Applications | |
|-----------------------|--|---------------------|--|
| Amplifiers | amplifier.ti.com | Audio | www.ti.com/audio |
| Data Converters | dataconverter.ti.com | Automotive | www.ti.com/automotive |
| DSP | dsp.ti.com | Broadband | www.ti.com/broadband |
| Interface | interface.ti.com | Digital Control | www.ti.com/digitalcontrol |
| Logic | logic.ti.com | Military | www.ti.com/military |
| Power Mgmt | power.ti.com | Optical Networking | www.ti.com/opticalnetwork |
| Microcontrollers | microcontroller.ti.com | Security | www.ti.com/security |
| RFID | www.ti-rfid.com | Telephony | www.ti.com/telephony |
| Low Power Wireless | www.ti.com/lpw | Video & Imaging | www.ti.com/video |
| | | Wireless | www.ti.com/wireless |