

- **Single-Chip Switching-Power-Supply Control With Limited External Components**
- **Built-In PWM Control Circuit**
- **Open-Collector Output for Direct Drive of Transformer**
- **Variable Dead-Time Control**
- **Overvoltage and Undervoltage Detection and Latch-Up for Each Supply Voltage: 5 V, 12 V, –5 V, and –12 V**
- **System Overcurrent Protection**
- **Wide Supply Range From 7 V to 40 V**
- **Power-Good Indicator Function**

**N PACKAGE
(TOP VIEW)**

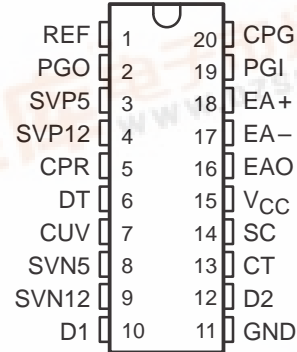

description

The TPS5206CN is a bipolar monolithic integrated circuit designed for push-pull-type switching-power-supply (SPS) control in desktop PC applications. It offers pulse-width-modulation (PWM) control and power-supply supervisor functions, including detection of undervoltage and overvoltage conditions on ± 5 V and ± 12 V system supplies. It also detects overcurrent conditions on the SPS system output. This single chip reduces the total component count and provides additional design flexibility, which minimizes cost and printed-circuit-board (PCB) space requirements in present and new SPS designs.

overvoltage-protection lockout feature

The overvoltage-protection lockout feature monitors four different supply voltages. When an overvoltage (OV) condition is detected, the power-good output (PGO) is set low and the PWM function is disabled. The OV condition is detected on the SVP5, SVP12, SVN5, and SVN12 inputs. Threshold voltages are typically 5.9 V, 14.1 V, –8.4 V, and –15.3 V, respectively.

undervoltage-protection lockout feature

The undervoltage-protection lockout feature monitors four different supply voltages. When an undervoltage (UV) condition is detected, the power-good output (PGO) is set low and the PWM function is disabled. The UV condition is detected on the SVP5, SVP12, SVN5, and SVN12 inputs. Threshold voltages are typically 3.9 V, 9.5 V, –3.4 V, and –9.3 V, respectively.

overcurrent-protection lockout feature

The overcurrent (OC) protection lockout feature is designed to protect the SPS from excessive load or short-circuit conditions. The circuit converts the output current of the SPS to a voltage, which is then monitored at SC. It sets PG low and shuts down the PWM circuit when the sensed voltage is higher than 5 V.

reference regulator

The internal 5-V reference regulator is designed primarily to provide the internal circuitry with a stable supply rail for varying input voltages. The regulator employs a band-gap circuit as its primary reference to maintain thermal stability of less than 100-mV variation over the operating free-air temperature range of 0°C to 70°C. In addition to supplying an internal reference, the regulator provides a precision 5-V reference that can support 5 mA of load current for external bias circuits. The regulated voltage has a margin of error of 2%. Short-circuit protection is provided to protect the internal circuit from overload or short-circuit conditions.



TPS5206CN

SWITCHING-POWER-SUPPLY CONTROL CIRCUIT

SLVS082A – APRIL 1994 – REVISED SEPTEMBER 1994

oscillator

The timing capacitor (CT) is charged by the oscillator with a 350- μ A current source set by the timing resistor (RT) (10 k Ω), internally. This produces a linear-ramp voltage waveform across CT. When the voltage across CT reaches 3 V, it is discharged by the oscillator circuit and the charging cycle is reinitiated. The frequency of the oscillator is programmable over a range of 1 kHz to 300 kHz by the selection of CT. The programmed frequency of the oscillator can be calculated with the equation $f = 1/(10^4 \times CT)$. The PWM output frequency is one-half of the oscillator frequency.

dead-time (DT) control

The DT input provides control of minimum dead time (off time). An input offset of 110 mV ensures a minimum dead time of 3% with the DT input grounded. Additional dead time can be imposed by applying voltage to the DT input. This provides a linear control of the dead time from its minimum of 3% to its maximum of 100% as the DT input voltage varies from 0 V to 3.3 V. The DT input is a relatively high-impedance input and is used where additional control of the output duty cycle is required. The input must be terminated; leaving this terminal open causes an undefined condition.

pulse-width modulation

The ramp voltage across CT is compared to the output of the error amplifier. The CT input incorporates a series diode, which is omitted from the DT control input. This requires the error-amplifier output to be 0.7-V greater than the voltage across CT to inhibit the PWM output. This also ensures PWM maximum-duty-cycle operation without requiring the control voltage to sink to true ground potential. The output pulse width varies from 97% of the period to 0 as the voltage at the error-amplifier output varies from 0.5 V to 3.5 V.

error amplifier

The high-gain error amplifier receives bias from the V_{CC} power rail. The inverting input, EA–, is biased by $V_{ref}/2$ internally. The amplifier output is biased low by a current sink to provide PWM maximum duty cycle when the amplifier is off. Since the amplifier output is biased low only through $I_{O(sink)}$ of 300 μ A (see functional block diagram), bias current required by external circuitry into the amplifier output for feedback must not exceed the capability of $I_{O(sink)}$; otherwise, the PWM maximum duty cycle is limited.

TPS5206CN SWITCHING-POWER-SUPPLY CONTROL CIRCUIT

SLVS082A – APRIL 1994 – REVISED SEPTEMBER 1994

functional block diagram

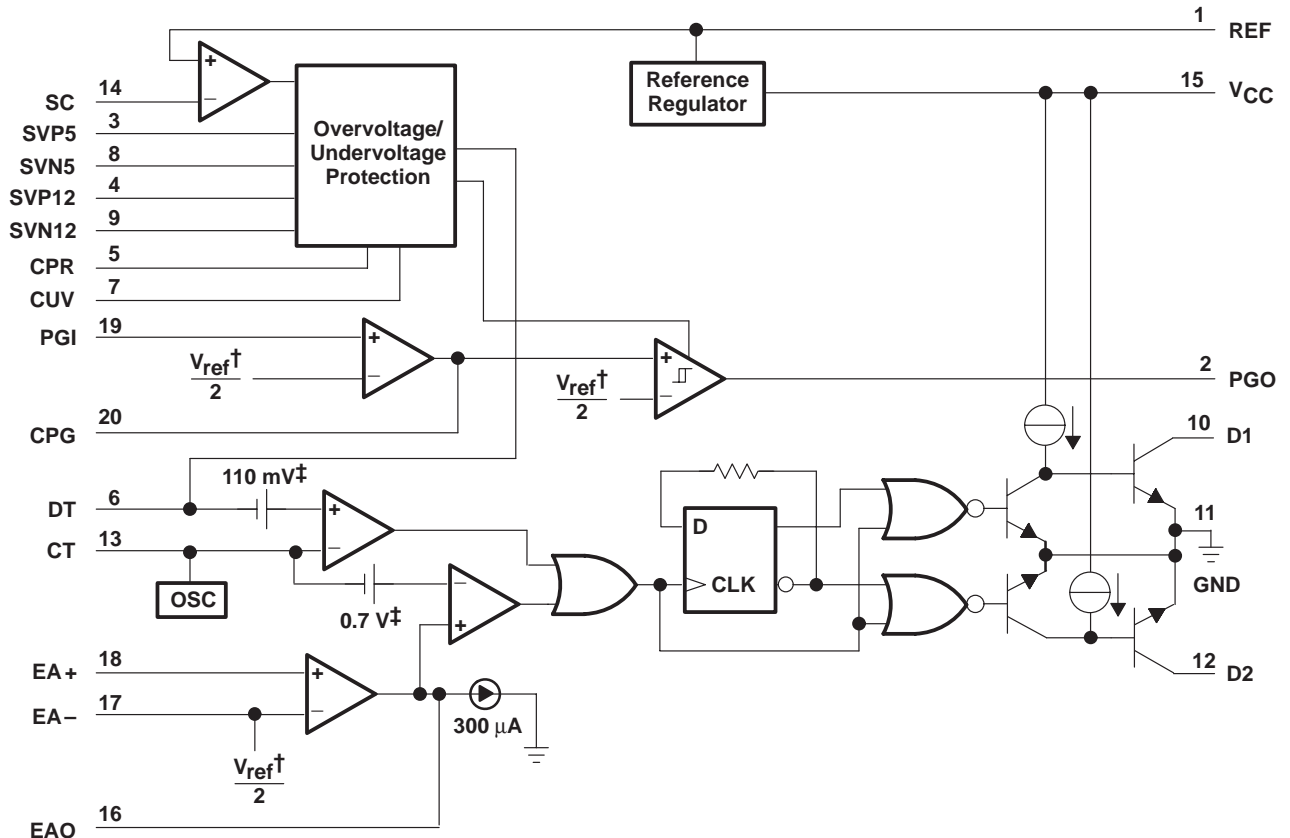

† Internally generated voltage

‡ Fixed-voltage offset

Terminal Functions

| TERMINAL NAME | NO. | I/O | DESCRIPTION |
|---------------|-----|-----|---|
| CPG | 20 | O | Power-good-capacitor connection. Connects a capacitor to power-good signal delay. |
| CPR | 5 | O | Protection-delay-capacitor connection. Connects a capacitor to protection-delay circuit to bypass high-frequency noise. |
| CT | 13 | O | Timing capacitor. Connects a capacitor to sawtooth oscillator circuit for programming the operating frequency. |
| CUV | 7 | O | UV capacitor connection. Connects a capacitor to UV power-on delay circuit to avoid malfunction in the initial state. |
| D1 | 10 | O | PWM driver-1 output |
| D2 | 12 | O | PWM driver-2 output |
| DT | 6 | I | Dead time. Control input to control the PWM minimum dead time (off time). |
| EA- | 17 | I | Error-amplifier inverting input |
| EA+ | 18 | I | Error-amplifier noninverting input |
| EAO | 16 | I/O | Error-amplifier output |
| GND | 11 | | Ground |
| PGI | 19 | I | Power-good input |
| PGO | 2 | O | Power-good output |
| REF | 1 | O | 5-V reference voltage output |
| SC | 14 | I | Overcurrent sense input. When an OV/UV condition is sensed, the TPS5206 output is locked and PGO is set to low. |

TPS5206CN

SWITCHING-POWER-SUPPLY CONTROL CIRCUIT

SLVS082A – APRIL 1994 – REVISED SEPTEMBER 1994

Terminal Functions (Continued)

| TERMINAL NAME | NO. | I/O | DESCRIPTION |
|-----------------|-----|-----|---|
| SVN5 | 8 | I | –5-V OV/UV detection input. When an OV/UV condition is sensed, the TLS1206 output is locked and PGO is set to low. |
| SVN12 | 9 | I | –12-V OV/UV detection input. When an OV/UV condition is sensed, the TLS1206 output is locked and PGO is set to low. |
| SVP5 | 3 | I | 5-V OV/UV detection input. When an OV/UV condition is sensed, the TLS1206 output is locked and PGO is set to low. |
| SVP12 | 4 | I | 12-V OV/UV detection input. When an OV/UV condition is sensed, the TLS1206 output is locked and PGO is set to low. |
| V _{CC} | 15 | | Supply voltage |

absolute maximum ratings over operating free-air temperature range (unless otherwise noted)†

| | |
|---|-------------------------|
| Supply voltage, V _{CC} | 41 V |
| Amplifier input voltage, V _I | V _{CC} + 0.3 V |
| Collector output voltage, V _O | 41 V |
| Collector output current, I _O | 250 mA |
| Total power dissipation at (or below) 25°C free-air temperature | 1 W |
| Operating free-air temperature range, T _A | 0°C to 70°C |
| Storage temperature range | –65°C to 70°C |

† Stresses beyond those listed under “absolute maximum ratings” may cause permanent damage to the device. These are stress ratings only, and functional operation of the device at these or any other conditions beyond those indicated under “recommended operating conditions” is not implied. Exposure to absolute-maximum-rated conditions for extended periods may affect device reliability.

DISSIPATION RATING TABLE

| PACKAGE | T _A ≤ 25°C POWER RATING | OPERATING FACTOR ABOVE T _A = 25°C | T _A = 70°C POWER RATING |
|---------|---------------------------------------|---|---------------------------------------|
| N | 1150 mW | 9.2 mW/°C | 736 mW |

recommended operating conditions

| | MIN | MAX | UNIT |
|---|------|-------|------|
| Supply voltage, V _{CC} | 7 | 40 | V |
| Collector output voltage, V _{O(D1)} , V _{O(D2)} | | 40 | V |
| Collector output current, I _{O(D1)} , I _{O(D2)} | | 150 | mA |
| Timing capacitor, CT | 0.47 | 10000 | nF |
| Operating free-air temperature, T _A | 0 | 70 | °C |

TPS5206CN SWITCHING-POWER-SUPPLY CONTROL CIRCUIT

SLVS082A – APRIL 1994 – REVISED SEPTEMBER 1994

electrical characteristics over recommended operating free-air temperature range, $V_{CC} = 15\text{ V}$

| PARAMETER | | TEST CONDITIONS | | MIN | TYP | MAX | UNIT |
|-------------------------------|---|--|--|------|-------|----------------|------|
| V_{ref} | Reference output voltage | $I_O = 5\text{ mA}$ | | 4.9 | 5 | 5.1 | V |
| $V_{IH(SC)}$ | High-level input voltage, SC overcurrent protection | SVP5 = 5 V, SVN5 = -5 V, $V_{O(DT)} \geq 3.5\text{ V}$ | SVP12 = 12 V, SVN12 = -12 V, | 5.1 | | | V |
| $V_{IL(SC)}$ | Low-level input voltage, SC overcurrent protection | SVP5 = 5 V, SVN5 = -5 V, $V_{O(DT)} \leq 0.4\text{ V}$ | SVP12 = 12 V, SVN12 = -12 V, | | | 4.9 | V |
| $V_{IT(UV)}$ | Input threshold voltage, undervoltage sense | SVP5 | SVP12 = 12 V, SVN12 = -12 V, $V_{O(DT)} \leq 0.4\text{ V}$ | 3.5 | 3.9 | 4.5 | V |
| | | SVP12 | SVP5 = 5 V, SVN12 = -12 V, $V_{O(DT)} \leq 0.4\text{ V}$ | 9 | 9.5 | 10.5 | |
| | | SVN5 | SVP5 = 5 V, SVN12 = -12 V, $V_{O(DT)} \leq 0.4\text{ V}$ | -3 | -3.4 | -4 | |
| | | SVN12 | SVP5 = 5 V, SVN5 = -5 V, $V_{O(DT)} \leq 0.4\text{ V}$ | -8 | -9.3 | -10 | |
| $V_{IT(OV)}$ | Input threshold voltage, overvoltage sense | SVP5 | SVP12 = 12 V, SVN12 = -12 V, $V_{O(DT)} \leq 0.4\text{ V}$ | 5.5 | 5.9 | 6.3 | V |
| | | SVP12 | SVP5 = 5 V, SVN12 = -12 V, $V_{O(DT)} \leq 0.4\text{ V}$ | 13.5 | 14.1 | 14.8 | |
| | | SVN5 | SVP5 = 5 V, SVN12 = -12 V, $V_{O(DT)} \leq 0.4\text{ V}$ | -7 | -8.4 | -9 | |
| | | SVN12 | SVP5 = 5 V, SVN5 = -5 V, $V_{O(DT)} \leq 0.4\text{ V}$ | -14 | -15.3 | -16 | |
| $V_{OL(D1)},$ $V_{OL(D2)}$ | Low-level output voltage, output drivers | $V_{O(DT)} \geq 3.5\text{ V}$ | $I_{OL} = 0$ $I_{OL} = 150\text{ mA}$ | | | 0.4 1.6 2.5 | V |
| $V_{O(DT)}$ | Dead-time output voltage | SVP5 = 7 V, | $I_{O(DT)} = -250\text{ }\mu\text{A}$ | 3.5 | | | V |
| $V_{IH(PGI)}$ | High-level input voltage, PGI | $V_{O(PGO)} \geq 4\text{ V}$, | See Figure 3 | 2.8 | | | V |
| $V_{IL(PGI)}$ | Low-level input voltage, PGI | $V_{O(PGO)} \leq 0.4\text{ V}$, | See Figure 3 | | | 2.42 | V |
| $V_{IH(CPG)}$ | High-level input voltage, CPG | $V_I(PGI) = 4\text{ V}$, See Figure 4 | $V_{O(PGO)} \geq 4\text{ V}$, | 2.95 | | | V |
| $V_{IL(CPG)}$ | Low-level input voltage, CPG | $V_I(PGI) = 4\text{ V}$, See Figure 4 | $V_{O(PGO)} \leq 0.4\text{ V}$, | | | 2.6 | V |
| $V_{OH(PGO)}$ | High-level output voltage, PGO | $V_{CPG} = 4\text{ V}$, See Figure 5 | $I_{O(PGO)} = -240\text{ }\mu\text{A}$, | 4.75 | | | V |
| $V_{OL(PGO)}$ | Low-level output voltage, PGO | $V_{CPG} = 0\text{ V}$, See Figure 6 | $I_{O(PGO)} = 9.6\text{ mA}$, | | | 0.4 | V |
| I_{CC} | Standby supply current | All other inputs and outputs open | | | | 32 | mA |
| f_{osc} | Oscillator frequency | $C_T = 1200\text{ pF}$ | | | 80 | | kHz |

switching characteristics over recommended ranges of supply voltage and operating free-air temperature

| PARAMETER | | TEST CONDITIONS | | MIN | TYP | MAX | UNIT |
|-----------|--------------------------|---|---------------------|-----|-----|-----|---------------|
| t_r | Rise time of power good | $V_{CPG} L \rightarrow H$, $V_{O(PGO)} L \rightarrow H$, | See Figures 4 and 6 | | | 100 | ns |
| t_d | Delay time of power good | $R_L = 150\text{ k}\Omega$, $C_{PG} = 2.2\text{ }\mu\text{F}$, $V_I(PGI) H \rightarrow L$, $V_{O(PGO)} H \rightarrow L$, | See Figures 4 and 6 | | 500 | 600 | μs |

TPS5206CN SWITCHING-POWER-SUPPLY CONTROL CIRCUIT

SLVS082A – APRIL 1994 – REVISED SEPTEMBER 1994

APPLICATION INFORMATION

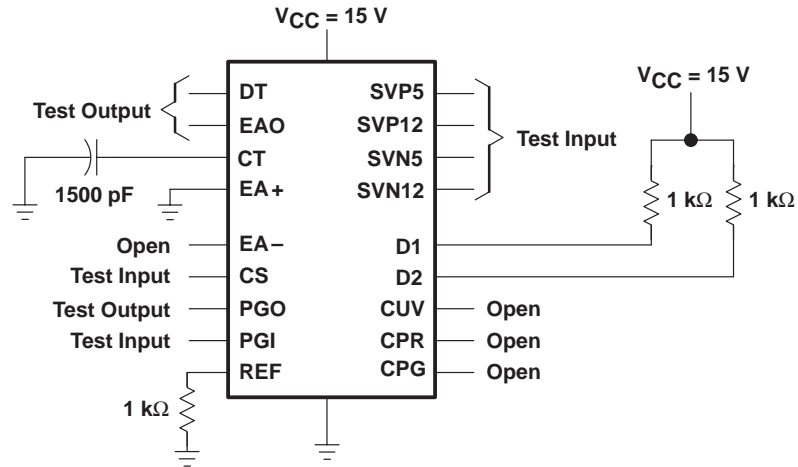

Figure 1. Test Circuit

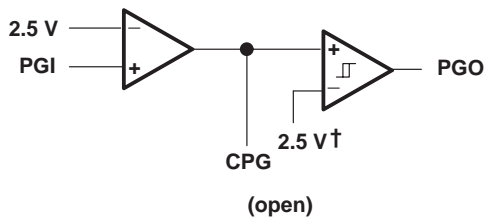

Figure 2. PGI Input Voltage Test Circuit

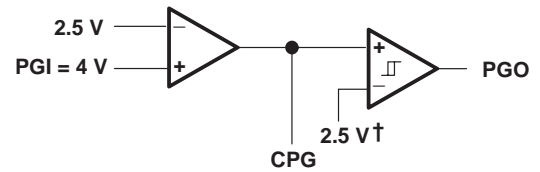

Figure 3. CPG Input Voltage and PGO Output Voltage Test Circuit

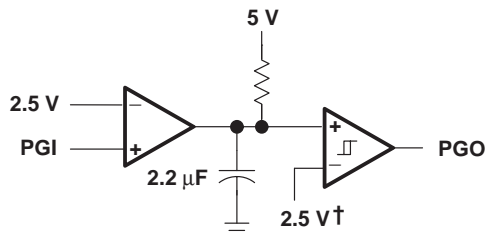

Figure 4. PG Delay Time and Rise Time Test Circuit

† Internally biased at $V_{ref}/2$ or 2.5 V

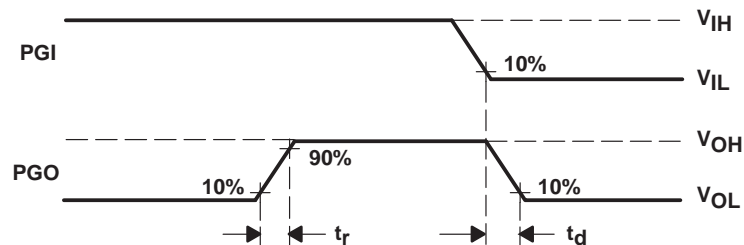

Figure 5. PG Output Voltage Waveform

IMPORTANT NOTICE

Texas Instruments and its subsidiaries (TI) reserve the right to make changes to their products or to discontinue any product or service without notice, and advise customers to obtain the latest version of relevant information to verify, before placing orders, that information being relied on is current and complete. All products are sold subject to the terms and conditions of sale supplied at the time of order acknowledgement, including those pertaining to warranty, patent infringement, and limitation of liability.

TI warrants performance of its semiconductor products to the specifications applicable at the time of sale in accordance with TI's standard warranty. Testing and other quality control techniques are utilized to the extent TI deems necessary to support this warranty. Specific testing of all parameters of each device is not necessarily performed, except those mandated by government requirements.

CERTAIN APPLICATIONS USING SEMICONDUCTOR PRODUCTS MAY INVOLVE POTENTIAL RISKS OF DEATH, PERSONAL INJURY, OR SEVERE PROPERTY OR ENVIRONMENTAL DAMAGE ("CRITICAL APPLICATIONS"). TI SEMICONDUCTOR PRODUCTS ARE NOT DESIGNED, AUTHORIZED, OR WARRANTED TO BE SUITABLE FOR USE IN LIFE-SUPPORT DEVICES OR SYSTEMS OR OTHER CRITICAL APPLICATIONS. INCLUSION OF TI PRODUCTS IN SUCH APPLICATIONS IS UNDERSTOOD TO BE FULLY AT THE CUSTOMER'S RISK.

In order to minimize risks associated with the customer's applications, adequate design and operating safeguards must be provided by the customer to minimize inherent or procedural hazards.

TI assumes no liability for applications assistance or customer product design. TI does not warrant or represent that any license, either express or implied, is granted under any patent right, copyright, mask work right, or other intellectual property right of TI covering or relating to any combination, machine, or process in which such semiconductor products or services might be or are used. TI's publication of information regarding any third party's products or services does not constitute TI's approval, warranty or endorsement thereof.