

3V HBT GaAs CDMA 4x4mm Power Amplifier Module

Functional Block Diagram

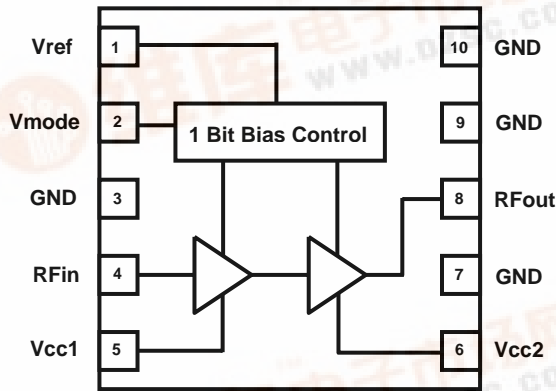

Product Description

The TQM713019 is a 3V, 2 stage GaAs HBT Power Amplifier Module designed for use in mobile phones. Its extremely small 4x4mm package makes it ideal for today's compact data enabled phones. Its RF performance meets the requirements for products designed to IS-95/98 standards.

The TQM713019 is designed on TriQuint's advanced InGaP HBT GaAs technology offering state of the art reliability, temperature stability, and ruggedness. Selectable bias mode and a shutdown mode with low leakage current improves talk and standby time. The output match, realized within the module package, optimizes efficiency/linearity at maximum rated output power. The module is a 4x4mm land grid array with backside ground. The TQM713019 is footprint compatible with industry standard 4x4mm CDMA PA modules.

Electrical Specifications

Parameter	Min	Typ	Max	Units
Frequency	824		849	MHz
CDMA mode maximum Pout ¹		28		dBm
Gain		29		dB
CDMA ACPR		50		dBc
CDMA ALTR		65		dBc
Power Supply Current @ 28dBm		450		mA
I _{REF}		2.0		mA
Rx Band Noise		-140		dBm/Hz

Note 1: CDMA Mode: V_{CC1}=3.4VDC, V_{CC2}=3.4VDC, V_{REF}=2.85VDC, T_C=25°C

Data Sheet: Subject to change without notice

For additional information and latest specifications, see our website: www.triquint.com

Rev. D, March 2005

Features

- InGaP HBT Technology
- High Efficiency: 41% CDMA
- Low Leakage Current: < 1uA
- Low I_{cq} = 55mA
- Supports new chipsets with V_{ref} @ 2.6V
- Capable of running as 0-bit PA in low bias mode to 28dBm
- Optimized for 50Ω system
- Small 10 pin 4x4mm module
- Excellent Rx band noise performance
- CDMA 1XRTT, 1XEV-DO compliant
- Full ESD protection

Applications

- IS-95 / CDMA2000
- Single mode, dual mode, and tri mode CDMA/AMPS phones

Package Style

4mm x 4mm LGA package

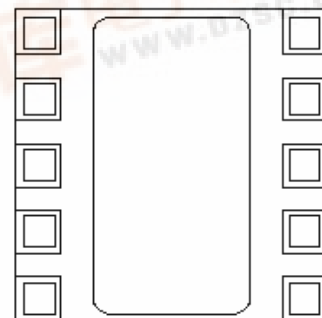

3V HBT GaAs CDMA 4x4mm Power Amplifier Module

Absolute Maximum Ratings

Symbol	Parameter	Absolute Maximum Value	Units
P _{IN}	RF Input Power	10	dBm
V _{CC}	Supply Voltage	0.0 to 5.0	V _{DC}
V _{REF}	Reference Voltage	0.0 to 3.5	V _{DC}
V _{MODE}	Vmode (1 bit Bias Control)	0.0 to 3.5	V _{DC}
T _{CASE}	Case Operating Temperature	-40 to +100	°C
T _{STORE}	Storage Temperature	-55 to +150	°C

Note: The part may not survive all maximums applied simultaneously.

Recommended Operating Conditions

Symbol	Parameter	Min.	Typ/Nom	Max.	Units
V _{CC}	Supply Voltage	3.2	3.4	4.2	V _{DC}
V _{REF}	Reference Voltage				
PA On		2.70	2.85	2.95	V _{DC}
PA Off		0	<0.5	-	V _{DC}
V _{MODE}	Vmode (1 bit Bias Control)				
High Bias Mode		0	-	0.5	V _{DC}
Low Bias Mode		2.5	2.85	3.0	V _{DC}
T _{CASE}	Case Operating Temperature	-30	25	+85	°C

Power Range Truth Table

Parameter	V _{REF}	V _{MODE}	Range
High Power	2.85 V	Low	16 dBm – 28 dBm
Low Power	2.85 V	High	< 16 dBm
Shut Down	0.0 V	Low	-

3V HBT GaAs CDMA 4x4mm Power Amplifier Module

CDMA (IS-98C) Electrical Characteristics¹

Parameter	Conditions	Min.	Typ/Nom	Max.	Units
RF Frequency		824		849	MHz
Large Signal Gain	$V_{CC} = 3.2$ to $4.2V$; $V_{REF} = 2.85V$; $-30^{\circ}C < Temp < 85^{\circ}C$				
Pout = +28 dBm		25	29	33	dB
Pout = +16 dBm		23	27		dB
Adjacent Channel Power (ACPR1) ²	$V_{CC} = 3.2$ to $4.2V$; $V_{REF} = 2.85V$; $-30^{\circ}C < Temp < 85^{\circ}C$				
+16dBm \leq Pout \leq +28dBm			-50	-45	dBc
Pout \leq +16dBm			-52	-45	dBc
Adjacent Channel Power (ACPR2) ²	$V_{CC} = 3.2$ to $4.2V$; $V_{REF} = 2.85V$; $-30^{\circ}C < Temp < 85^{\circ}C$				
+16dBm \leq Pout \leq +28dBm			-60	-57	dBc
Pout \leq +16dBm			-65	-57	dBc
Quiescent Current	$V_{CC} = 3.4V$; $V_{REF} = 2.85V$; $V_{MODE} = 2.85V$; $Temp = 25^{\circ}C$		55		mA
I _{REF}	Pout = +28dBm; $V_{CC} = 3.4V$; $V_{REF} = 2.85V$; $V_{MODE} = 0V$; $Temp = 25^{\circ}C$		2	3	mA
I _{MODE}	All Conditions			75	uA
PAE	Pout = +28dBm; $V_{CC} = 3.4V$; $V_{REF} = 2.85V$; $V_{MODE} = 0V$; $Temp = 25^{\circ}C$		41		%
PAE	Pout = +16dBm; $V_{CC} = 3.4V$; $V_{REF} = 2.85V$; $V_{MODE} = 2.85V$; $Temp = 25^{\circ}C$		9.5		%
Input VSWR	All Terminals		1.5 :1	2.0 :1	
Harmonics	Pout \leq +28dBm				
2fo			-50	-40	dBc
3fo			-65	-40	dBc
Spurious / Stability	Pout \leq +28dBm; 10:1 VSWR; $V_{CC} = 3.2$ to $4.2V$; $-30^{\circ}C < Temp < 85^{\circ}C$			-65	dBc
Ruggedness	10:1 VSWR; Pin = +10dBm; $-30^{\circ}C < Temp < 85^{\circ}C$		No degradation		
Noise Power in Rx Band	Pout = +28dBm, IS-95 Standard		-140	-135	dBm/Hz

Note 1: Test Conditions: $V_{CC}=3.4V_{DC}$, $V_{REF}=2.85V_{DC}$, $T_C = 25^{\circ}C$ unless otherwise specified; TriQuint Test Board

Note 2: ACPR1 Measured @ $\pm 885kHz$ Offset; ACPR2 Measured @ $\pm 1.98MHz$

3V HBT GaAs CDMA 4x4mm Power Amplifier Module

cdma2000 (IS-98D) Electrical Characteristics^{1,3}

Parameter	Conditions	Min.	Typ/Nom	Max.	Units
RF Frequency		824		849	MHz
Large Signal Gain	$V_{CC} = 3.2$ to $4.2V$; $V_{REF} = 2.85V$; $-30^{\circ}C < Temp < 85^{\circ}C$				
Pout = +27.5 dBm		25	28.5		dB
Pout = +16 dBm		23	27		dB
Adjacent Channel Power (ACPR1) ²	$V_{CC} = 3.2$ to $4.2V$; $V_{REF} = 2.85V$; $-30^{\circ}C < Temp < 85^{\circ}C$				
+16dBm \leq Pout \leq +27.5dBm			-50	-45	dBc
Pout \leq +16dBm			-55	-45	dBc
Adjacent Channel Power (ACPR2) ²	$V_{CC} = 3.2$ to $4.2V$; $V_{REF} = 2.85V$; $-30^{\circ}C < Temp < 85^{\circ}C$				
+16dBm \leq Pout \leq +27.5dBm			-60	-57	dBc
Pout \leq +16dBm			-65	-57	dBc
Quiescent Current	$V_{CC} = 3.4V$; $V_{REF} = 2.85V$; $V_{MODE} = 2.85V$; Temp = $25^{\circ}C$		55		mA
I _{REF}	Pout = +27.5dBm; $V_{CC} = 3.4V$; $V_{REF} = 2.85V$; $V_{MODE} = 0V$; Temp = $25^{\circ}C$		2	3	mA
I _{MODE}	All Conditions			75	uA
PAE	Pout = +27.5dBm; $V_{CC} = 3.4V$; $V_{REF} = 2.85V$; $V_{MODE} = 0V$; Temp = $25^{\circ}C$		40		%
PAE	Pout = +16dBm; $V_{CC} = 3.4V$; $V_{REF} = 2.85V$; $V_{MODE} = 2.85V$; Temp = $25^{\circ}C$		9.5		%
Input VSWR	All Terminals		1.5 : 1	2.0 : 1	
Noise Power in Rx Band	Pout = +28dBm, IS-95 Standard		-140	-135	dBm/Hz

Note 1: Test Conditions: $V_{CC}=3.4V_{DC}$, $V_{REF}=2.85V_{DC}$, $T_C = 25^{\circ}C$ unless otherwise specified; TriQuint Test Board

Note 2: ACPR1 Measured @ $\pm 885kHz$ Offset; ACPR2 Measured @ $\pm 1.98MHz$

Note 3: 9600 bps Fundamental and Supplemental Traffic Channels (0 dB), peak-to-average ratio (CCDF=1%) = 4.5dB

AMPS Mode Electrical Characteristics¹

Parameter	Conditions	Min.	Typ/Nom	Max.	Units
RF Frequency		824		849	MHz
High Power Output, Pout			31.5		dBm
Large Signal Gain			27.5		dB
PAE	Pout = 31.5dBm; $V_{CC} = 3.4V$; Temp = $25^{\circ}C$	50	57		%

Note 1: Test Conditions: $V_{CC}=3.4V_{DC}$, $V_{REF}=2.85V_{DC}$, $T_C = 25^{\circ}C$ unless otherwise specified; TriQuint Test Board

Data Sheet: Subject to change without notice

For additional information and latest specifications, see our website: www.triquint.com

Rev. D, March 2005

3V HBT GaAs CDMA 4x4mm Power Amplifier Module

Pin Out and Assignments

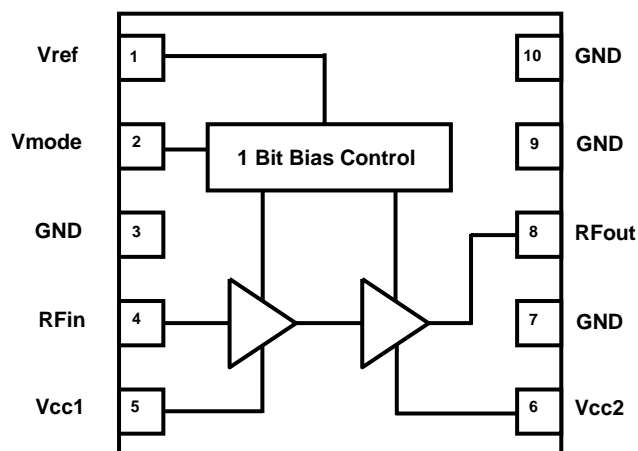

Pin	Symbol	Description
1	V_{REF}	Regulated voltage for bias setting. V_{REF} is set to $0V_{DC}$ to power off the TQM713019
2	V_{MODE}	1 step bias control
3	GND	Ground
4	RF_{IN}	RF input. The RF circuit is DC grounded internally ² . 50 Ohm RF impedance.
5	V_{CC1}	Collector voltage for input stage
6	V_{CC2}	Collector voltage for output stage
7	GND	Ground
8	RF_{OUT}	RF output. The RF circuit is DC blocked internally. 50 Ohm RF impedance
9	GND	Ground
10	GND	Ground
Paddle ¹	GND	Device ground and thermal path for heat removal

Note 1: TriQuint recommends the use of several via holes to the backside ground under the paddle

Note 2: Internal DC ground for RF_{IN}

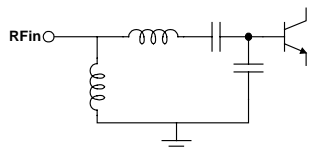

3V HBT GaAs CDMA 4x4mm Power Amplifier Module

Typical Performance

Test Conditions (Unless Otherwise Specified): $V_{CC}=3.4V_{DC}$, $V_{REF}=2.85V_{DC}$, $V_{MODE}=0$ or $2.85V_{DC}$, $P_{OUT}=28.0$ or $16dBm$

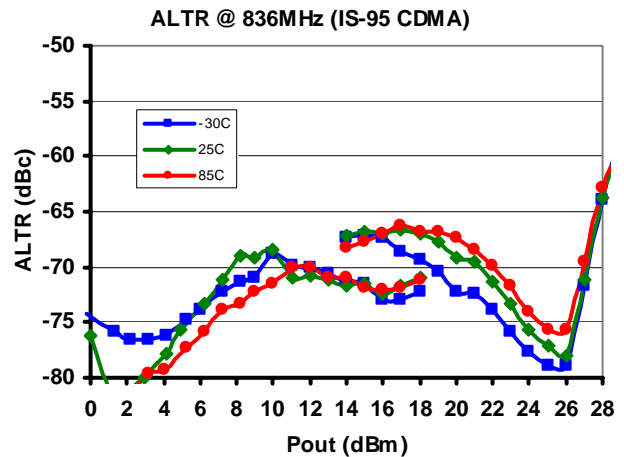
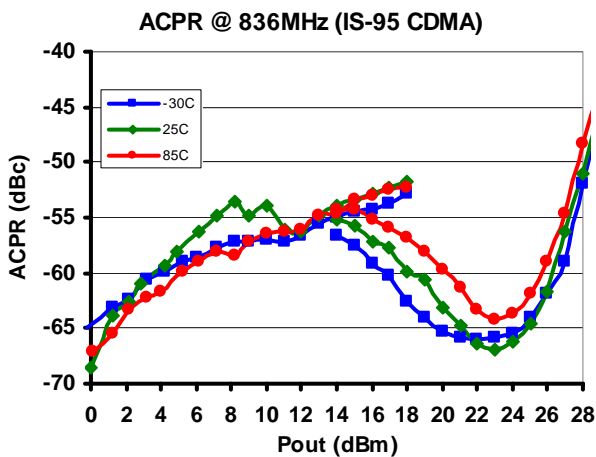
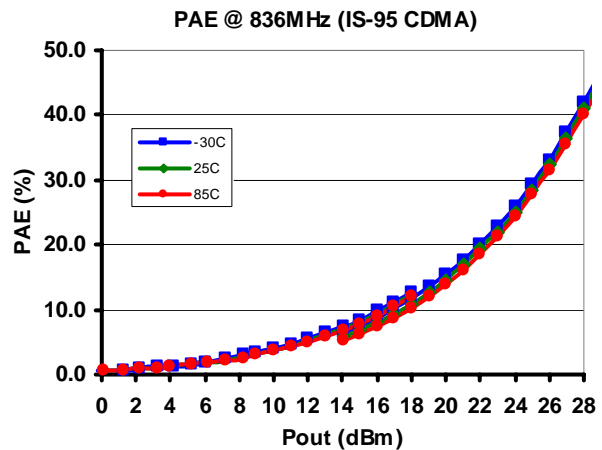
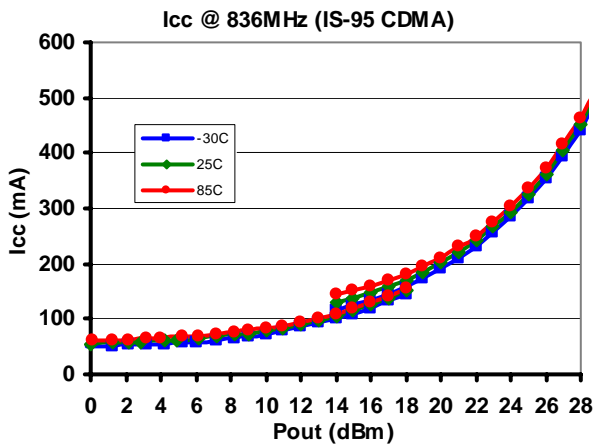

3V HBT GaAs CDMA 4x4mm Power Amplifier Module

Typical Performance (Continued)

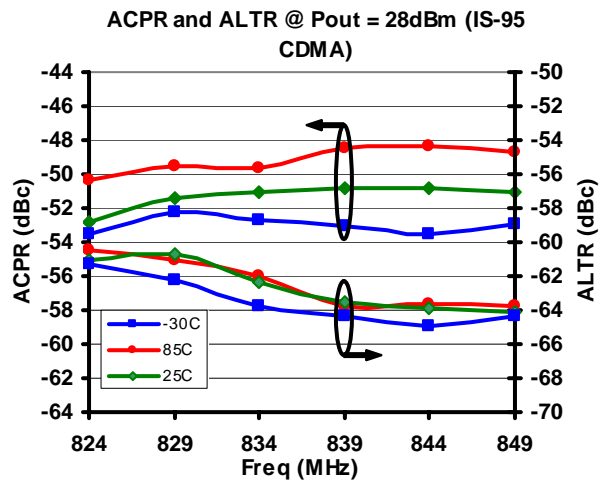
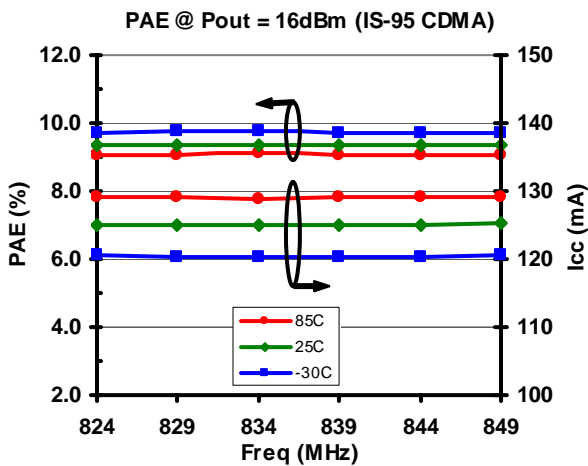
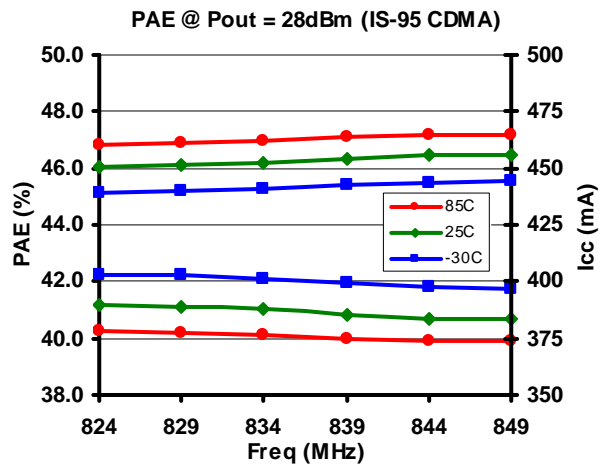
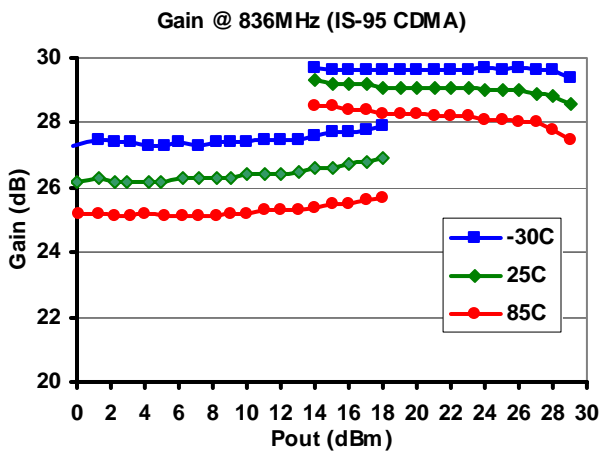

3V HBT GaAs CDMA 4x4mm Power Amplifier Module

Typical Performance (Continued)

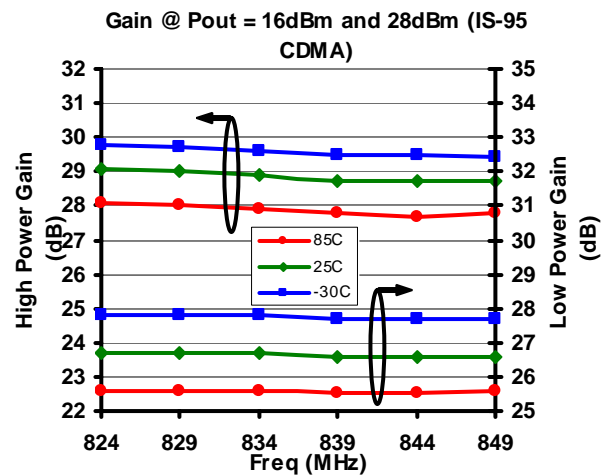
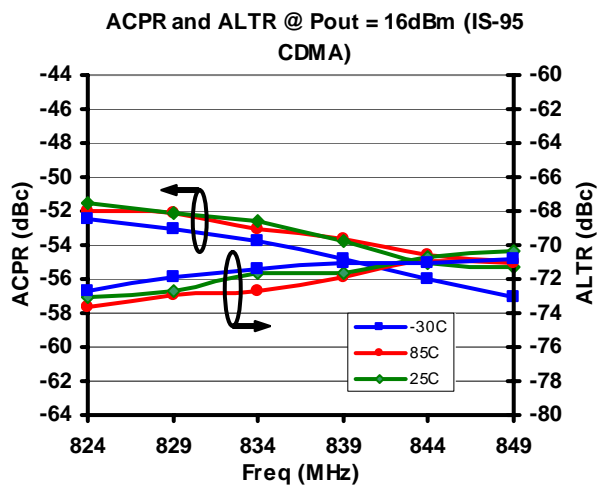

3V HBT GaAs CDMA 4x4mm Power Amplifier Module

Application Information; tuning procedures; board layout precautions

TriQuint offers our customers the below evaluation board as a means for testing and analysis of TQM713019. The evaluation board schematic and picture are provided for preliminary analysis and design. Figure 1 shows the TriQuint application board, while Figure 2 shows the schematic of the board.

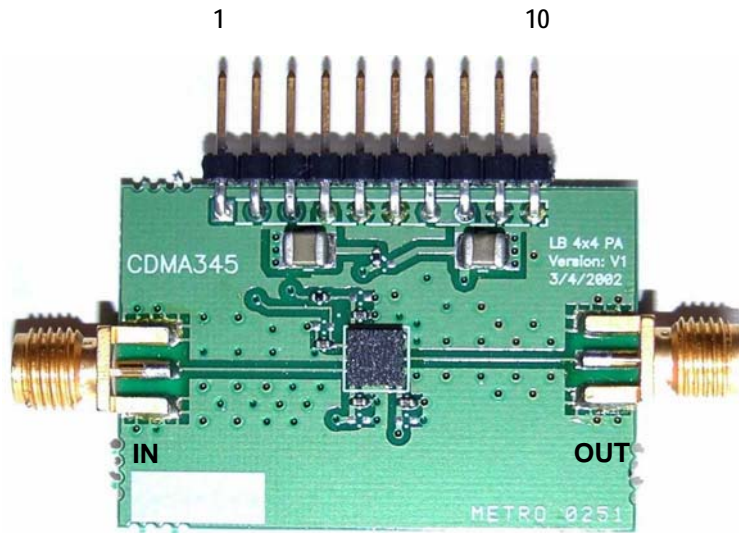

Pin #	Function
1	No Connect
2	Vmode, High/low Bias Mode
3	Vref, Reference Voltage
4	Vcc1, 1 st Stage Collector Voltage
5	GND, DC Ground
6	GND, DC Ground
7	Vcc2, 2 nd Stage Collector Voltage
8	Vcc2, 2 nd Stage Collector Voltage
9	GND, DC Ground
10	GND, DC Ground

Figure 1: Evaluation Board

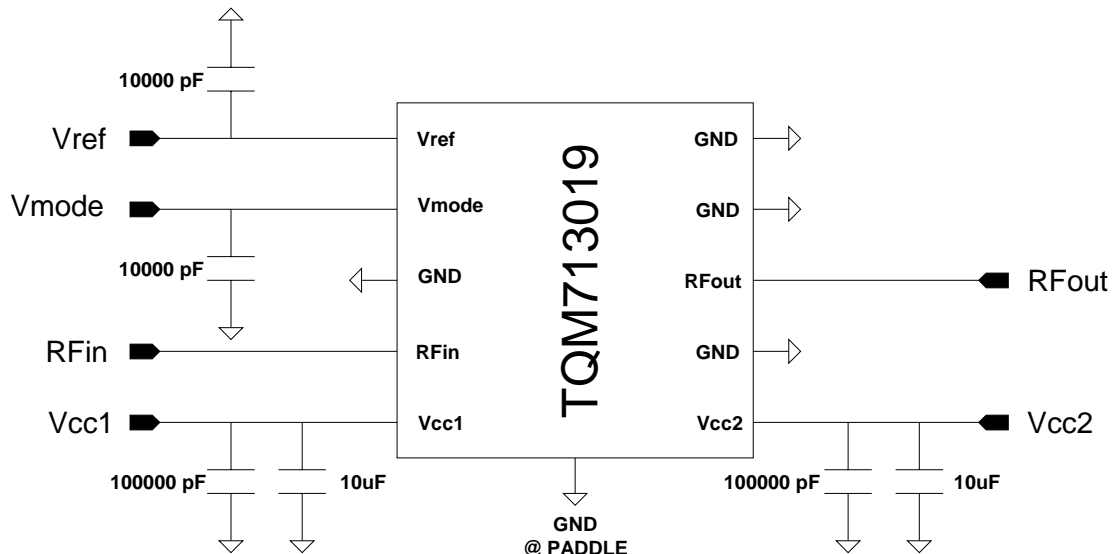
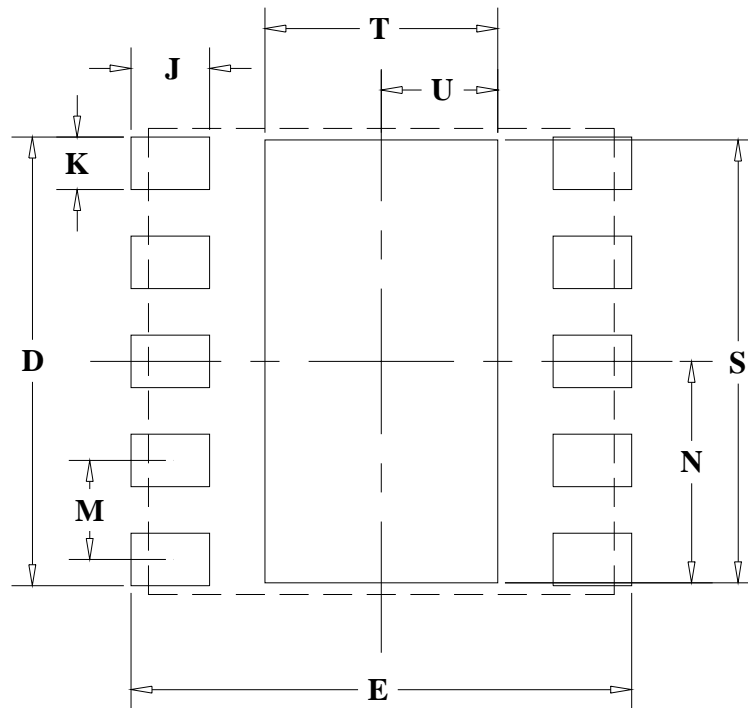

Figure 2: Evaluation Board Schematic

3V HBT GaAs CDMA 4x4mm Power Amplifier Module

PC Board Layout Recommendations



DIMENSION	MM
D	3.85
E	4.30
J	0.68
K	0.45
M	0.85
N	1.90
S	3.80
T	2.00
U	1.00

Note1: Only ground signal traces are allowed directly under the package

Note 2: Primary dimensions are in millimeters alternate dimensions are in inches.

3V HBT GaAs CDMA 4x4mm Power Amplifier Module

Packaging and Ordering Information

Package Type: 10 Pin Plastic Module Package

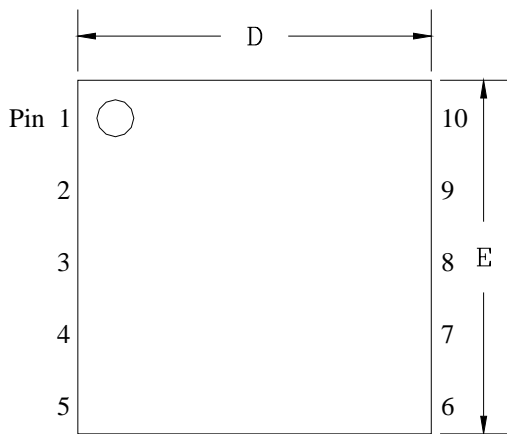

Top View

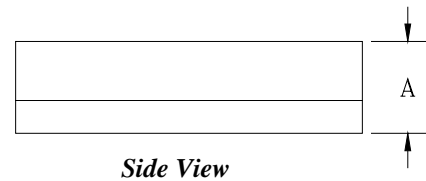

Side View

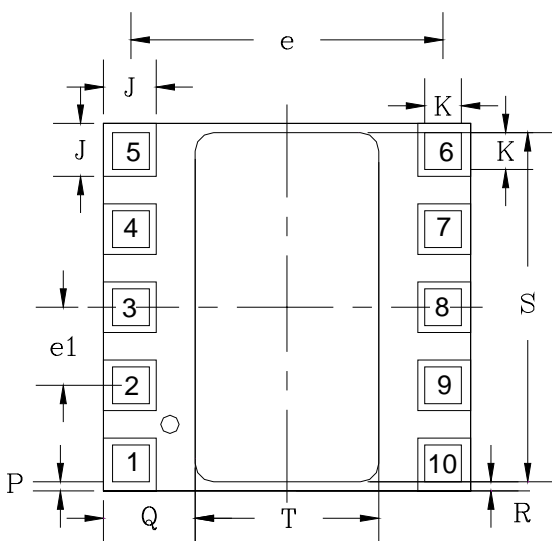

Bottom View

DESIGNATION	DESCRIPTION	DIMENSION
A	OVERALL HEIGHT	1.5 +/-0.12 mm
D	PACKAGE LENGTH	4.0 +/-0.1 mm
E	PACKAGE WIDTH	4.0 +/-0.1 mm
J	SOLDER MASK OPENING LENGTH AND WIDTH	0.575 +/-0.075 mm
K	METAL PAD LENGTH AND WIDTH	0.40 +/-0.05 mm
P	DISTANCE BETWEEN METAL PAD AND PACKAGE EDGE	0.10 +/-0.025 mm
T	GND SOLDER MASK OPENING WIDTH	2.00 +/-0.05 mm
S	GND SOLDER MASK OPENING LENGTH	3.80 +/-0.05 mm
R	DISTANCE BETWEEN GND SOLDER MASK OPENING AND PACKAGE EDGE	0.10 +/-0.1 mm
Q	DISTANCE BETWEEN GND SOLDER MASK OPENING AND PACKAGE EDGE	1.00 +/-0.1 mm
e	TERMINAL PITCH FOR TERMINAL 1-10, 2-9, 3-8, 4-7 AND 5-6	3.400 mm
e1	TERMINAL PITCH FOR TERMINAL 1-2-3-4-5 AND 6-7-8-9-10	0.850 mm

Note: GND SOLDER MASK OPENING IS NOT CENTERED ON THE PACKAGE

3V HBT GaAs CDMA 4x4mm Power Amplifier Module

Package Marking



Top View

WHITE INK OR LASER MARK

Line 1: Part Number: 713019

Line 2: YYWW = Year and Work Week

Line 3: XXXX = TriQuint assembly lot number

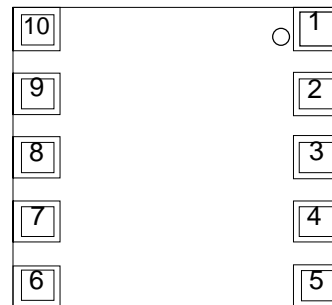

Bottom View

3V HBT GaAs CDMA 4x4mm Power Amplifier Module

Tape & Reel

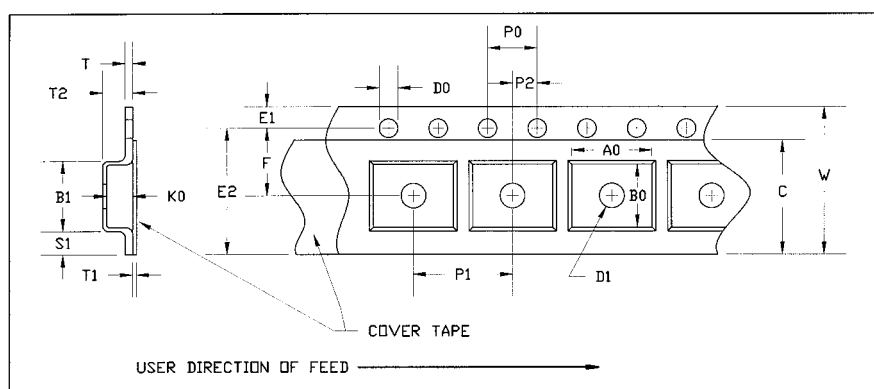

PART	FEATURE	SYMBOL	SIZE (in)	SIZE (mm)
CAVITY	LENGTH	A0	0.171	4.35
	WIDTH	B0	0.171	4.35
	DEPTH	K0	0.071	1.80
	PITCH	P1	0.315	8.00
DISTANCE BETWEEN CENTERLINE	CAVITY TO PERFORATION LENGTH DIRECTION	P2	0.079	2.00
	CAVITY TO PERFORATION WIDTH DIRECTION	F	0.217	5.50
COVER TAPE	WIDTH	C	0.362	9.20
CARRIER TAPE	WIDTH	W	0.472	12.00

3V HBT GaAs CDMA 4x4mm Power Amplifier Module

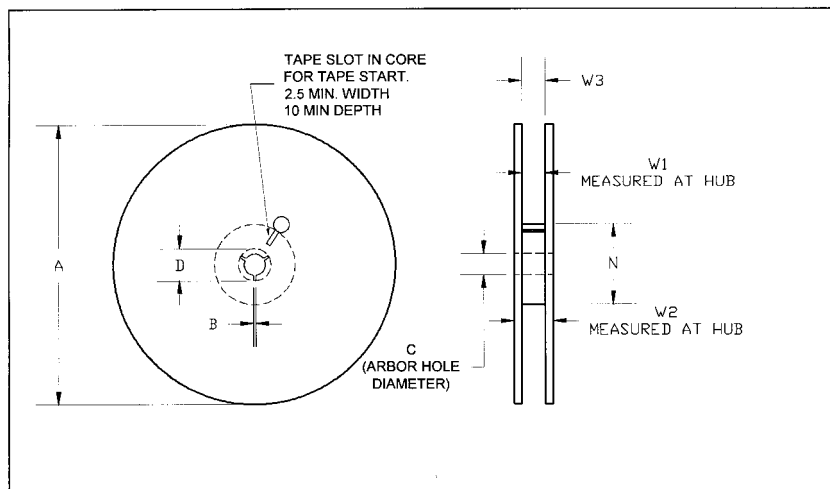

SOIC-8, QSOP 16, MSOP 08 & 10, TSSOP 16, HP VFQFP-N 4X4 & 5X5, VQFN-24, VQFN-20. Modules 4X4			13" REEL	
PART	FEATURE	SYMBOL	SIZE (in)	SIZE (mm)
FLANGE	DIAMETER	A	12.992	330
	THICKNESS	W2	0.717	18.2
	SPACE BETWEEN FLANGE	W1	0.504	12.8
HUB	OUTER DIAMETER	N	4.016	102.0
	ARBOR HOLE DIAMETER	C	0.512	13.0
	KEY SLIT WIDTH	B	0.079	2.0
	KEY SLIT DIAMETER	D	0.787	20.0

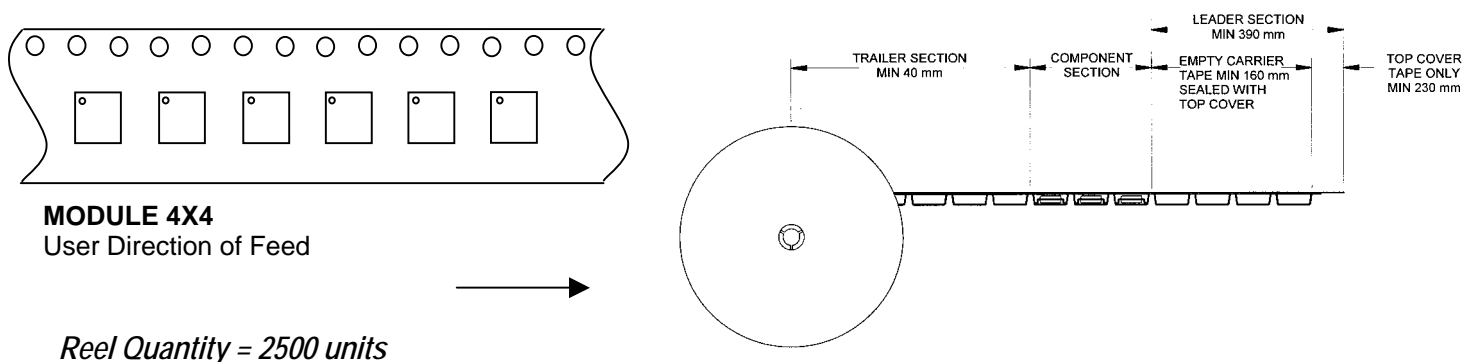

Reel Quantity = 2500 units

3V HBT GaAs CDMA 4x4mm Power Amplifier Module

Additional Information¹T

1 For latest specifications, additional product information, worldwide sales and distribution locations, and information about TriQuint:

Web: www.triquint.com

Tel: (503) 615-9000

Email: info_wireless@tqs.com

Fax: (503) 615-8902

For technical questions and additional information on specific applications:

Email: info_wireless@tqs.com

The information provided herein is believed to be reliable; TriQuint assumes no liability for inaccuracies or omissions. TriQuint assumes no responsibility for the use of this information, and all such information shall be entirely at the user's own risk. Prices and specifications are subject to change without notice. No patent rights or licenses to any of the circuits described herein are implied or granted to any third party.

TriQuint does not authorize or warrant any TriQuint product for use in life-support devices and/or systems.

Copyright © 2004 TriQuint Semiconductor, Inc. All rights reserved.

Data Sheet: Subject to change without notice

For additional information and latest specifications, see our website: www.triquint.com

Rev. D, March 2005