



查询TSL260R-LF供应商

**TAOS**

TEXAS  
ADVANCED  
OPTOELECTRONIC  
SOLUTIONS®

捷多邦, 专业PCB打样, 小批量生产

# TSL260R, TSL261R, TSL262R INFRARED LIGHT-TO-VOLTAGE OPTICAL SENSORS

TAOS049E –SEPTEMBER 2007

- Integral Visible Light Cutoff Filter
- Monolithic Silicon IC Containing Photodiode, Operational Amplifier, and Feedback Components
- Converts Light Intensity to a Voltage
- High Irradiance Responsivity, Typically 111 mV/( $\mu\text{W}/\text{cm}^2$ ) at  $\lambda_p = 940 \text{ nm}$  (TSL260R)
- Compact 3-Lead Plastic Package
- Single Voltage Supply Operation
- Low Dark (Offset) Voltage....10mV Max
- Low Supply Current.....1.1 mA Typical
- Wide Supply-Voltage Range.... 2.7 V to 5.5 V
- Replacements for TSL260, TSL261, and TSL262
- RoHS Compliant (–LF Package Only)

PACKAGE S  
SIDELOOKER  
(FRONT VIEW)

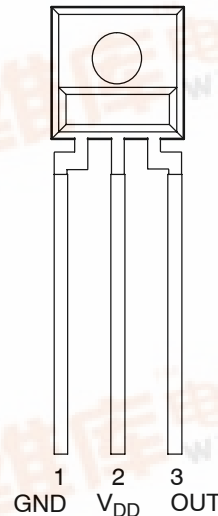

PACKAGE SM  
SURFACE MOUNT  
SIDELOOKER  
(FRONT VIEW)

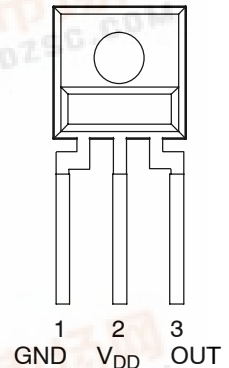

## Description

The TSL260R, TSL261R, and TSL262R are infrared light-to-voltage optical sensors, each combining a photodiode and a transimpedance amplifier (feedback resistor = 16 M $\Omega$ , 8 M $\Omega$ , and 2.8 M $\Omega$  respectively) on a single monolithic IC. Output voltage is directly proportional to the light intensity (irradiance) on the photodiode. These devices have improved amplifier offset-voltage stability and low power consumption and are supplied in a 3-lead plastic sidelooker package with an integral visible light cutoff filter and lens. When supplied in the lead (Pb) free package, the device is RoHS compliant.

## Functional Block Diagram

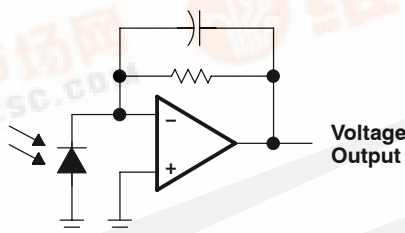

## Available Options

DEVICE	T <sub>A</sub>	PACKAGE - LEADS	PACKAGE DESIGNATOR	ORDERING NUMBER
TSL260R	0°C to 70°C	3-lead Sidelooker	S	TSL260R
TSL260R	0°C to 70°C	3-lead Sidelooker — Lead (Pb) Free	S	TSL260R-LF
TSL260R	0°C to 70°C	3-lead Surface-Mount Sidelooker — Lead (Pb) Free	SM	TSL260RSM-LF
TSL261R	0°C to 70°C	3-lead Sidelooker	S	TSL261R
TSL261R	0°C to 70°C	3-lead Sidelooker — Lead (Pb) Free	S	TSL261R-LF
TSL261R	0°C to 70°C	3-lead Surface-Mount Sidelooker — Lead (Pb) Free	SM	TSL261RSM-LF
TSL262R	0°C to 70°C	3-lead Sidelooker	S	TSL262R
TSL262R	0°C to 70°C	3-lead Sidelooker — Lead (Pb) Free	S	TSL262R-LF
TSL262R	0°C to 70°C	3-lead Surface-Mount Sidelooker — Lead (Pb) Free	SM	TSL262RSM-LF



LUMINOLOGY® Company

Texas Advanced Optoelectronic Solutions Inc.

1001 Klein Road, Suite 300 • Plano, TX 75074 • (972) 672-0750

Copyright © 2007, TAOS Inc.

# TSL260R, TSL261R, TSL262R INFRARED LIGHT-TO-VOLTAGE OPTICAL SENSORS

TAOS049E –SEPTEMBER 2007

## Terminal Functions

TERMINAL		DESCRIPTION
NAME	NO.	
GND	1	Ground (substrate). All voltages are referenced to GND.
OUT	3	Output voltage
V <sub>DD</sub>	2	Supply voltage

## Absolute Maximum Ratings over operating free-air temperature range (unless otherwise noted)<sup>†</sup>

Supply voltage, V <sub>DD</sub> (see Note 1)	6 V
Output current, I <sub>O</sub>	±10 mA
Duration of short-circuit current at (or below) 25°C (see Note 2)	5 s
Operating free-air temperature range, T <sub>A</sub>	–25°C to 85°C
Storage temperature range, T <sub>stg</sub>	–25°C to 85°C
Lead temperature 1,6 mm (1/16 inch) from case for 10 seconds (S Package)	260°C
Reflow solder, in accordance with J-STD-020C or J-STD-020D (SM Package)	260°C

<sup>†</sup> Stresses beyond those listed under “absolute maximum ratings” may cause permanent damage to the device. These are stress ratings only, and functional operation of the device at these or any other conditions beyond those indicated under “recommended operating conditions” is not implied. Exposure to absolute-maximum-rated conditions for extended periods may affect device reliability.

NOTES: 1. All voltages are with respect to GND.  
2. Output may be shorted to supply.

## Recommended Operating Conditions

	MIN	NOM	MAX	UNIT
Supply voltage, V <sub>DD</sub>	2.7		5.5	V
Operating free-air temperature, T <sub>A</sub>	0		70	°C

# TSL260R, TSL261R, TSL262R INFRARED LIGHT-TO-VOLTAGE OPTICAL SENSORS

TAOS049E –SEPTEMBER 2007

**Electrical Characteristics at  $V_{DD} = 5\text{ V}$ ,  $T_A = 25^\circ\text{C}$ ,  $\lambda_p = 940\text{ nm}$ ,  $R_L = 10\text{ k}\Omega$  (unless otherwise noted) (see Notes 3, 4, and 5)**

PARAMETER	TEST CONDITIONS	TSL260R			TSL261R			TSL262R			UNIT
		MIN	TYP	MAX	MIN	TYP	MAX	MIN	TYP	MAX	
$V_D$ Dark voltage	$E_e = 0$	0	4	10	0	4	10	0	4	10	mV
$V_{OM}$ Maximum output voltage	$V_{DD} = 4.5\text{ V}$	3	3.3		3	3.3		3	3.3		V
$V_O$ Output voltage	$E_e = 18\ \mu\text{W}/\text{cm}^2$	1	2	3							V
	$E_e = 46\ \mu\text{W}/\text{cm}^2$				1	2	3				
	$E_e = 220\ \mu\text{W}/\text{cm}^2$							1	2	3	
$\alpha_{vo}$ Temperature coefficient of output voltage ( $V_O$ )	$E_e = 18\ \mu\text{W}/\text{cm}^2$ , $T_A = 0^\circ\text{C}$ to $70^\circ\text{C}$	8									mV/ $^\circ\text{C}$
		0.4									%/ $^\circ\text{C}$
	$E_e = 46\ \mu\text{W}/\text{cm}^2$ , $T_A = 0^\circ\text{C}$ to $70^\circ\text{C}$				8						mV/ $^\circ\text{C}$
					0.4						%/ $^\circ\text{C}$
$E_e = 220\ \mu\text{W}/\text{cm}^2$ , $T_A = 0^\circ\text{C}$ to $70^\circ\text{C}$							8			mV/ $^\circ\text{C}$	
							0.4			%/ $^\circ\text{C}$	
$N_e$ Irradiance responsivity	See Note 6	111			43.5			9.1			mV/ $(\mu\text{W}/\text{cm}^2)$
$I_{DD}$ Supply current	$E_e = 18\ \mu\text{W}/\text{cm}^2$	1.1			1.7						mA
	$E_e = 46\ \mu\text{W}/\text{cm}^2$				1.1			1.7			
	$E_e = 220\ \mu\text{W}/\text{cm}^2$							1.1			

- NOTES: 3. Measurements are made with  $R_L = 10\text{ k}\Omega$  between output and ground.  
 4. Optical measurements are made using small-angle incident radiation from an LED optical source.  
 5. The input irradiance  $E_e$  is supplied by a GaAs LED with peak wavelength  $\lambda_p = 940\text{ nm}$   
 6. Irradiance responsivity is characterized over the range  $V_O = 0.05$  to  $2.9\text{ V}$ . The best-fit straight line of Output Voltage  $V_O$  versus irradiance  $E_e$  over this range will typically have a positive extrapolated  $V_O$  value for  $E_e = 0$ .

## Dynamic Characteristics at $T_A = 25^\circ\text{C}$ (see Figure 1)

PARAMETER	TEST CONDITIONS	TSL260R			TSL261R			TSL262R			UNIT
		MIN	TYP	MAX	MIN	TYP	MAX	MIN	TYP	MAX	
$t_r$ Output pulse rise time	$V_{DD} = 5\text{ V}$ , $\lambda_p = 940\text{ nm}$	260			70			7			$\mu\text{s}$
$t_f$ Output pulse fall time	$V_{DD} = 5\text{ V}$ , $\lambda_p = 940\text{ nm}$	260			70			7			$\mu\text{s}$
$V_n$ Output noise voltage	$V_{DD} = 5\text{ V}$ , $E_e = 0$ , $f = 1000\text{ Hz}$	0.8			0.7			0.6			$\mu\text{V}/\sqrt{\text{Hz}}$

# TSL260R, TSL261R, TSL262R INFRARED LIGHT-TO-VOLTAGE OPTICAL SENSORS

TAOS049E –SEPTEMBER 2007

## PARAMETER MEASUREMENT INFORMATION

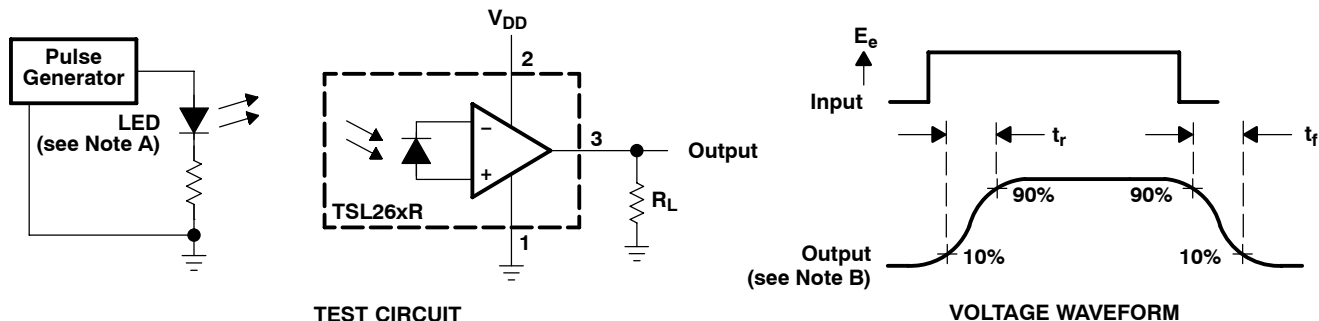

- NOTES: A. The input irradiance is supplied by a pulsed GaAs light-emitting diode with the following characteristics:  $\lambda_p = 940 \text{ nm}$ ,  $t_r < 1 \mu\text{s}$ ,  $t_f < 1 \mu\text{s}$ .  
 B. The output waveform is monitored on an oscilloscope with the following characteristics:  $t_r < 100 \text{ ns}$ ,  $Z_i \geq 1 \text{ M}\Omega$ ,  $C_i \leq 20 \text{ pF}$ .

Figure 1. Switching Times

## TYPICAL CHARACTERISTICS

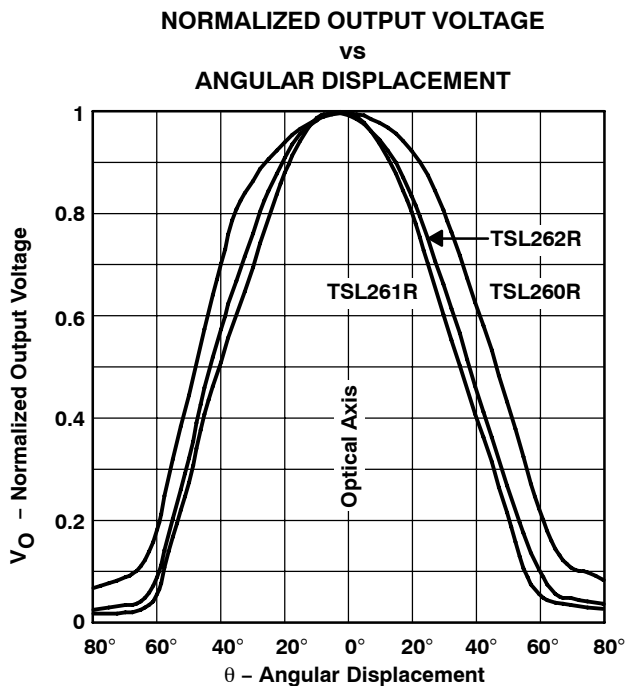
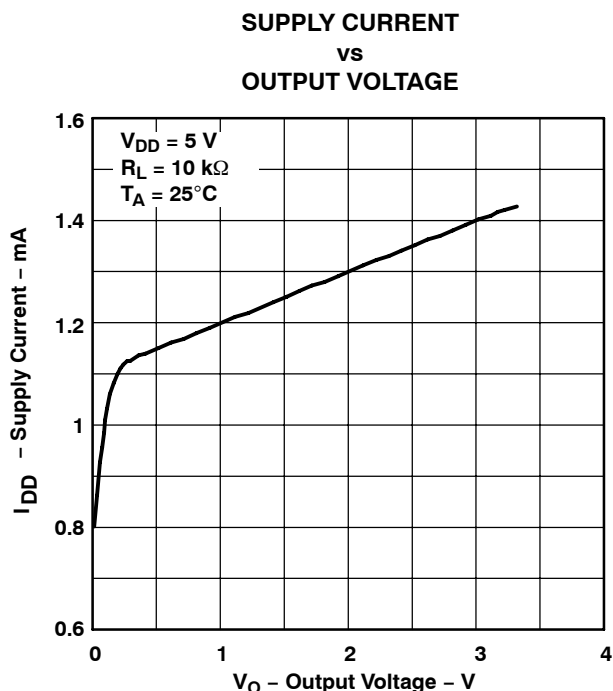
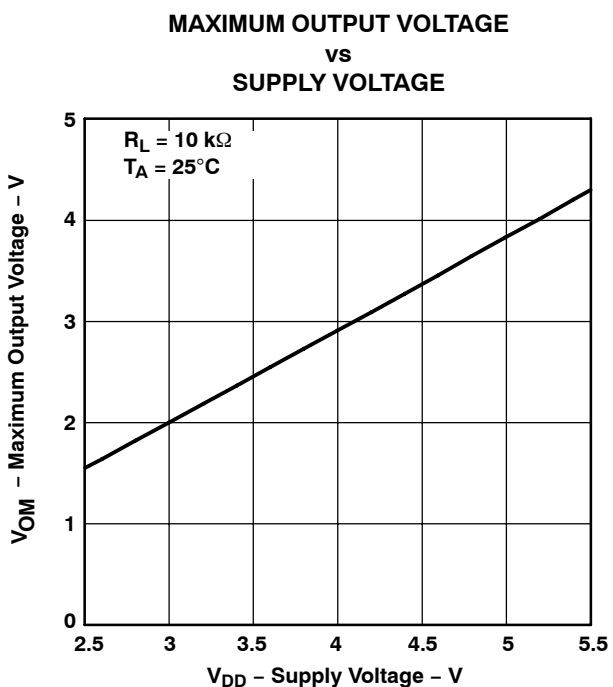
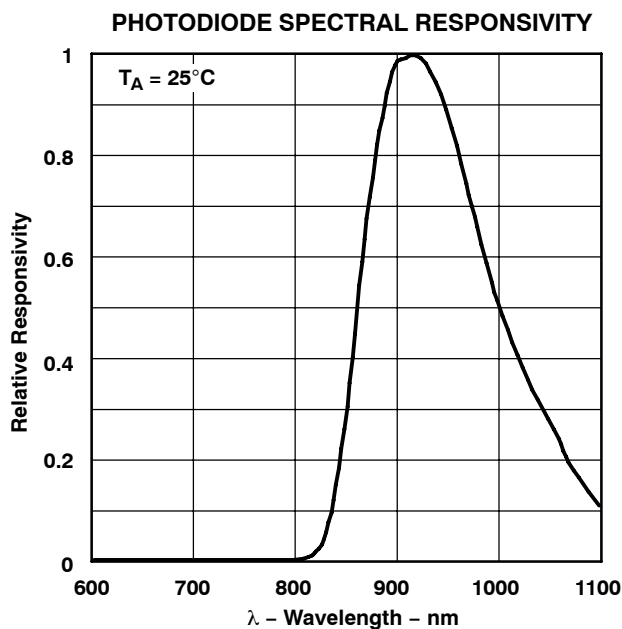
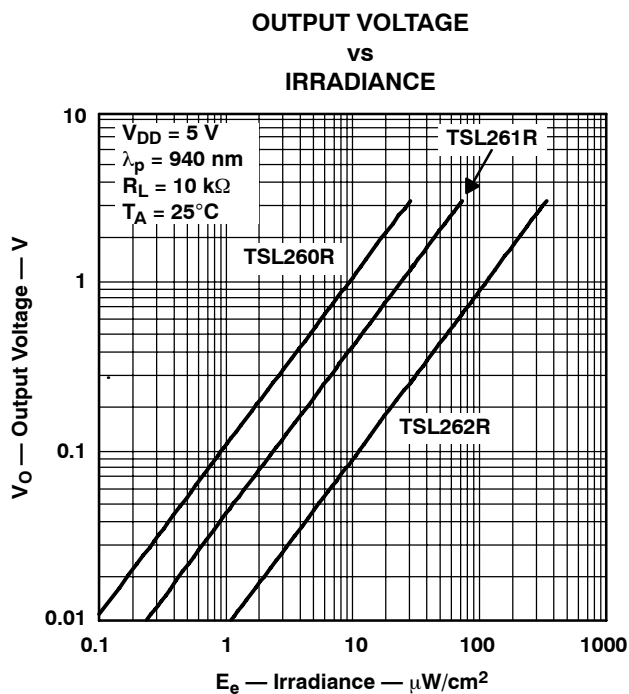

Figure 2

# TSL260R, TSL261R, TSL262R INFRARED LIGHT-TO-VOLTAGE OPTICAL SENSORS

TAOS049E - SEPTEMBER 2007

## TYPICAL CHARACTERISTICS



# TSL260R, TSL261R, TSL262R INFRARED LIGHT-TO-VOLTAGE OPTICAL SENSORS

TAOS049E –SEPTEMBER 2007

## APPLICATION INFORMATION

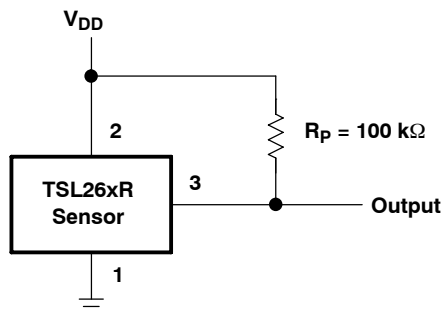

NOTE A: Pullup resistor extends linear output range to near V<sub>DD</sub> with minimal (several millivolts typical) effect on V<sub>DARK</sub>; particularly useful at low V<sub>DD</sub> (3 V to 5 V).

Figure 7. Pullup for Increased V<sub>OM</sub>

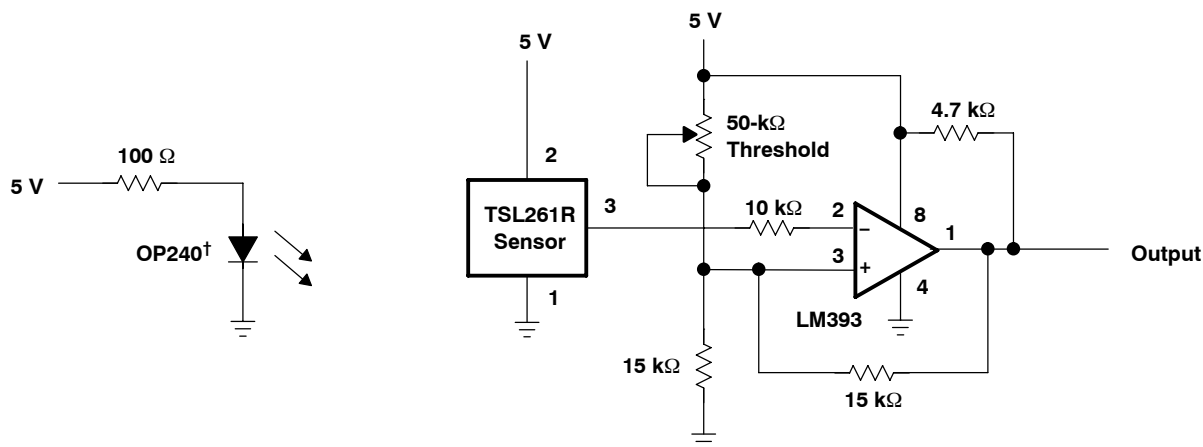

<sup>†</sup> OPTEK part number

NOTE A: Output goes high when beam is interrupted; working distance is several inches or less. Intended for use as optical-interrupter switch or reflective-object sensor.

Figure 8. Short-Range Optical Switch With Hysteresis

# TSL260R, TSL261R, TSL262R INFRARED LIGHT-TO-VOLTAGE OPTICAL SENSORS

TAOS049E - SEPTEMBER 2007

## APPLICATION INFORMATION

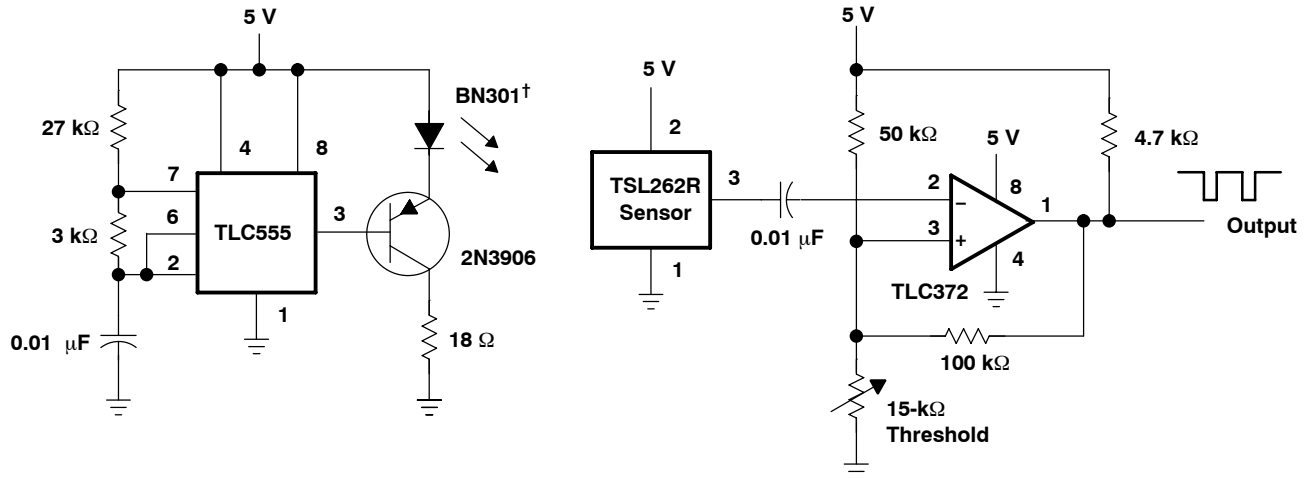

† Stanley part number

NOTE A: Output pulses low until beam is interrupted. Useful range is 1 ft to 20 ft; can be extended with lenses. This configuration is suited for object detection, safety guards, security systems, and automatic doors.

Figure 9. Pulsed Optical-Beam Interrupter

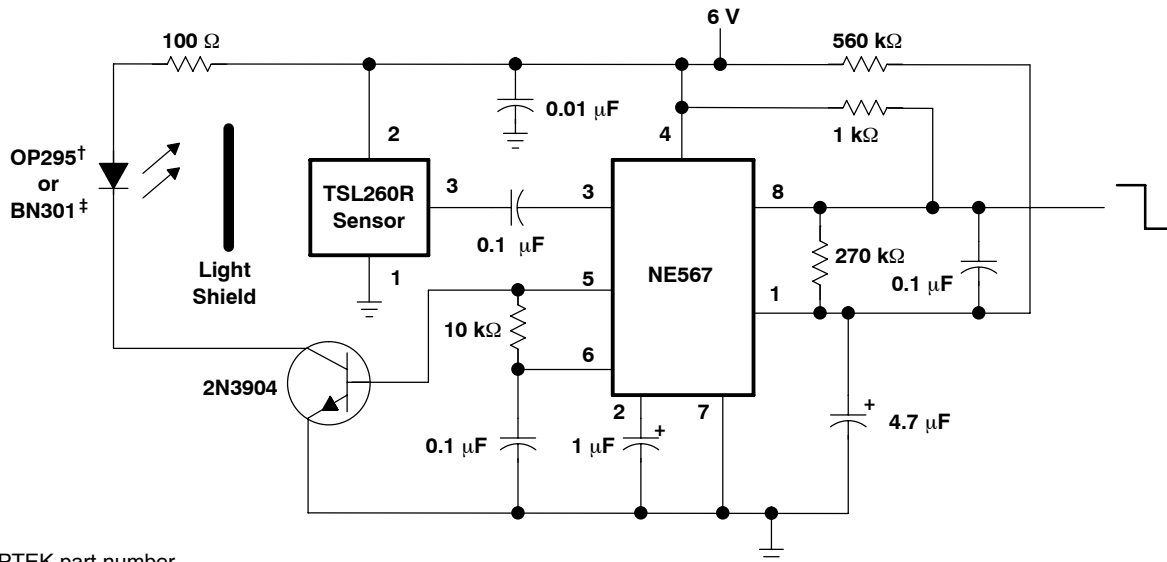

† OPTEK part number

‡ Stanley part number

NOTE A: Output goes low when light pulses from emitter are reflected back to sensor. Range is 6 in to 18 in depending upon object reflectance. Useful for automatic doors, annunciators, object avoidance in robotics, automatic faucets, and security systems.

Figure 10. Proximity Detector

# TSL260R, TSL261R, TSL262R INFRARED LIGHT-TO-VOLTAGE OPTICAL SENSORS

TAOS049E –SEPTEMBER 2007

## APPLICATION INFORMATION

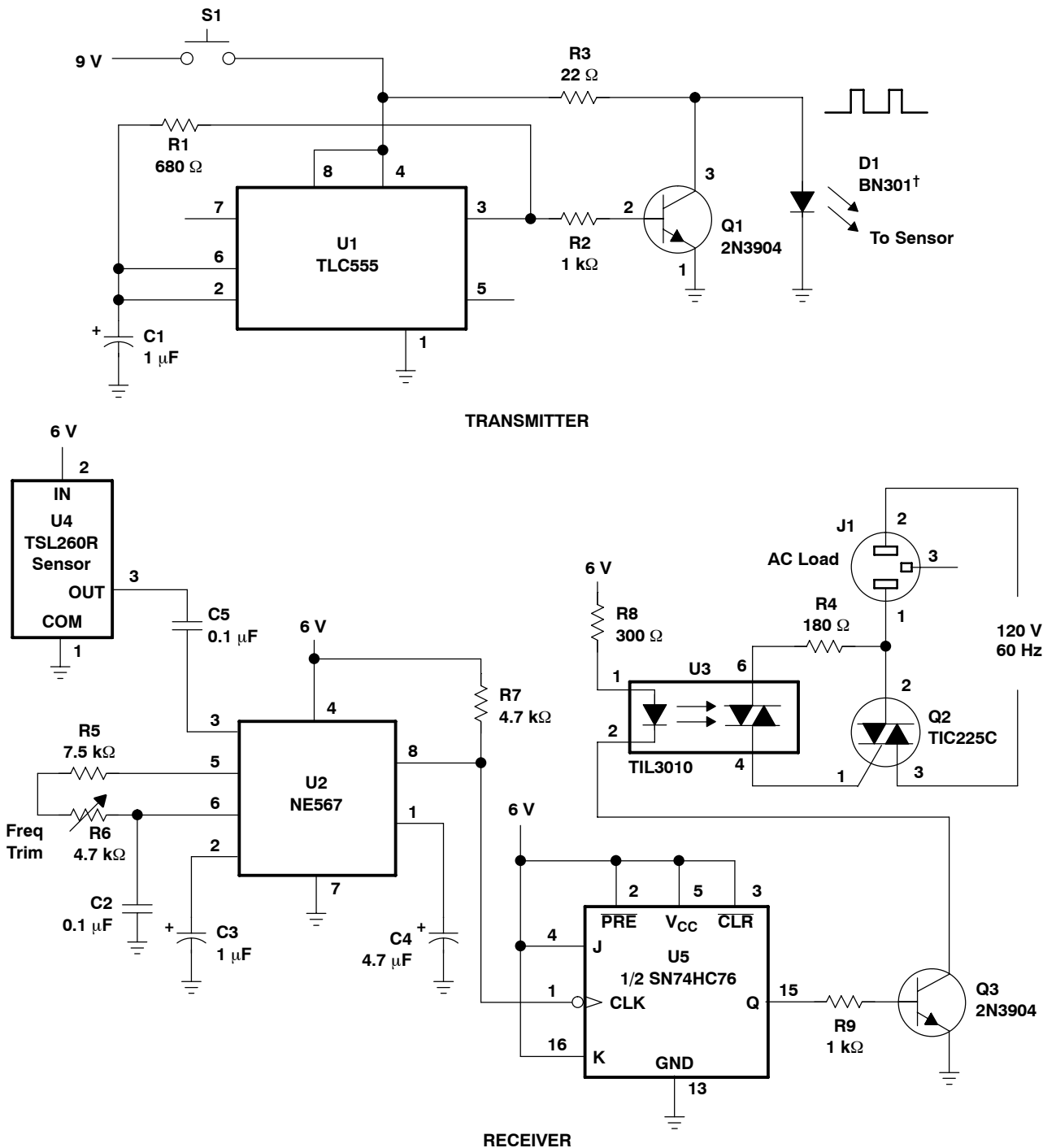

† OPTEK part number

NOTE A: Single-channel remote control can be used to switch logic or light dc loads by way of U5 or ac loads by way of the optocoupler and triac as shown. Applications include ceiling fans, lamps, electric heaters, etc.

Figure 11. IR Remote Control



# TSL260R, TSL261R, TSL262R INFRARED LIGHT-TO-VOLTAGE OPTICAL SENSORS

TAOS049E - SEPTEMBER 2007

## APPLICATION INFORMATION

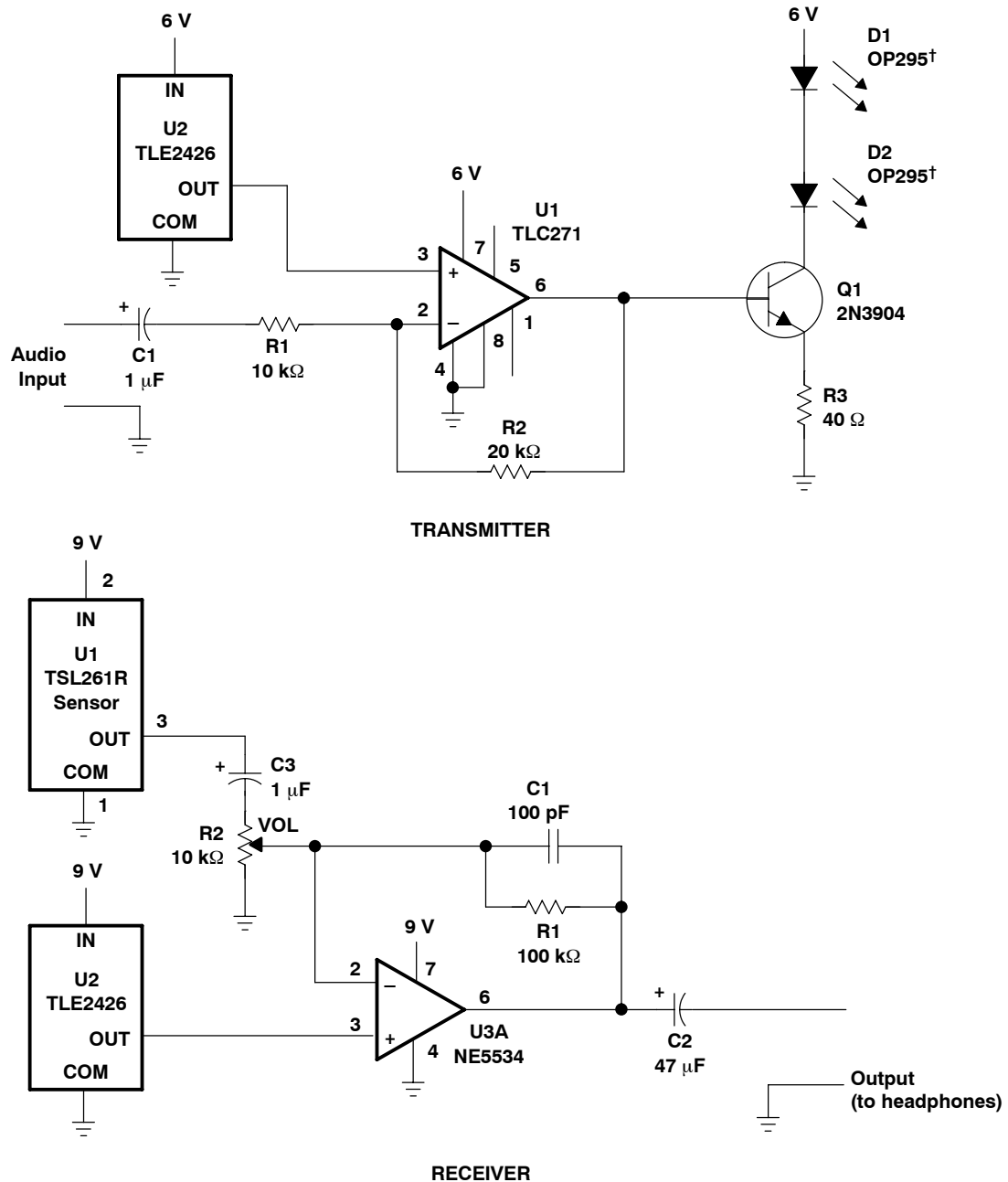

† OPTEK part number

NOTE A: Simple transmission of audio signal over short distances (<10 ft). Applications include wireless headphones, wireless-telephone headset, and wireless-headset intercom.

Figure 12. IR Voice-Band Audio Link

# TSL260R, TSL261R, TSL262R INFRARED LIGHT-TO-VOLTAGE OPTICAL SENSORS

TAOS049E –SEPTEMBER 2007

## APPLICATION INFORMATION

### PCB Pad Layout

Suggested PCB pad layout guidelines for the SM surface mount package are shown in Figure 16.

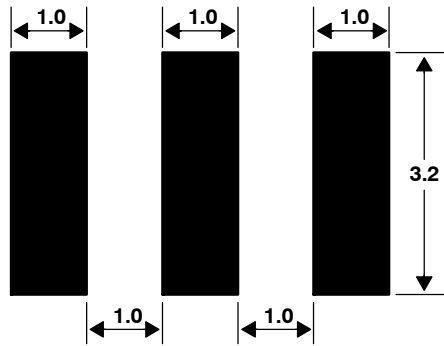

- NOTES: A. All linear dimensions are in millimeters.  
B. This drawing is subject to change without notice.

**Figure 13. Suggested SM Package PCB Layout**

# TSL260R, TSL261R, TSL262R INFRARED LIGHT-TO-VOLTAGE OPTICAL SENSORS

TAOS049E - SEPTEMBER 2007

## MECHANICAL DATA

The TSL260R, TSL261R, and TSL262R are supplied in a clear 3-lead through-hole package with a molded lens. The integrated photodiode active area is typically 1,0 mm<sup>2</sup> (0.0016 in<sup>2</sup>) for TSL260R, 0,5 mm<sup>2</sup> (0.00078 in<sup>2</sup>) for the TSL261R, and 0,26 mm<sup>2</sup> (0.0004 in<sup>2</sup>) for the TSL262R.

### PACKAGE S

### PLASTIC SINGLE-IN-LINE SIDE-LOOKER PACKAGE

#### TOP VIEW

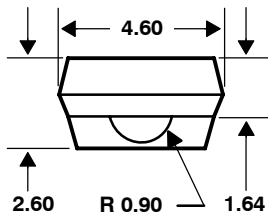

#### FRONT VIEW

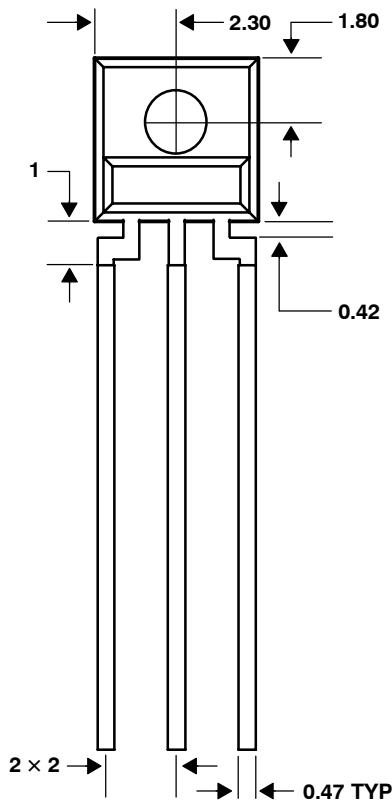

#### SIDE VIEW

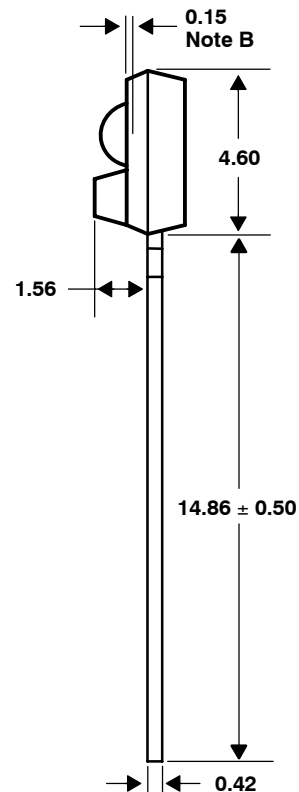

Lead Free  
Available

- NOTES: A. All linear dimensions are in millimeters; tolerance is  $\pm 0.25$  mm unless otherwise stated.  
 B. Dimension is to center of lens arc, which is located below the package face.  
 C. The integrated photodiode active area is typically located in the center of the lens and 0.97 mm below the top of the lens surface.  
 D. Index of refraction of clear plastic is 1.55.  
 E. Lead finish for TSL26xR: solder dipped, 63% Sn/37% Pb. Lead finish for TSL26xR-LF: solder dipped, 100% Sn.  
 F. This drawing is subject to change without notice.

Figure 14. Package S — Single-In-Line Side-Looker Package Configuration

# TSL260R, TSL261R, TSL262R INFRARED LIGHT-TO-VOLTAGE OPTICAL SENSORS

TAOS049E –SEPTEMBER 2007

## MECHANICAL DATA

### PACKAGE SM

### PLASTIC SURFACE MOUNT SIDE-LOOKER PACKAGE

#### TOP VIEW

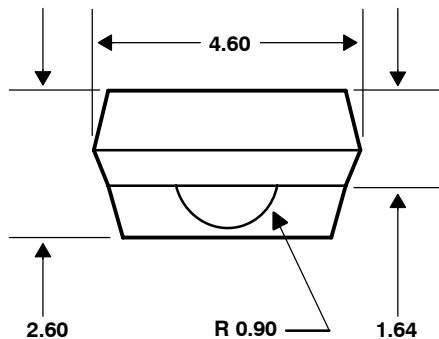

#### FRONT VIEW

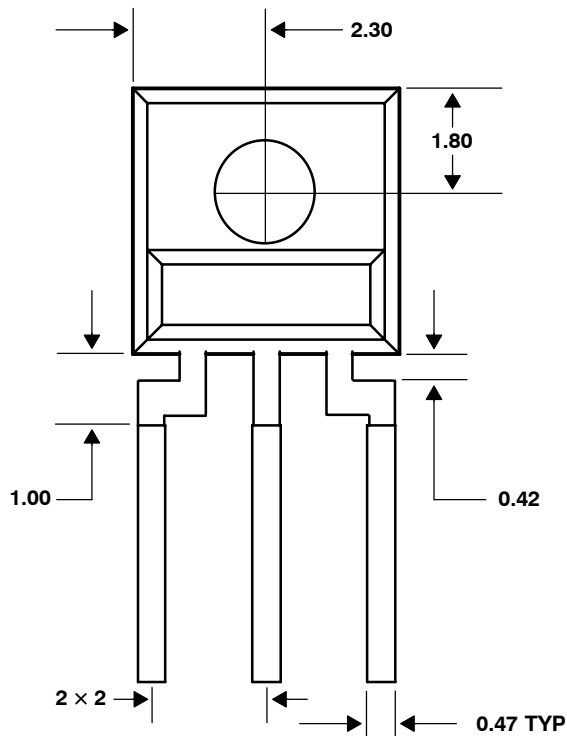

#### SIDE VIEW

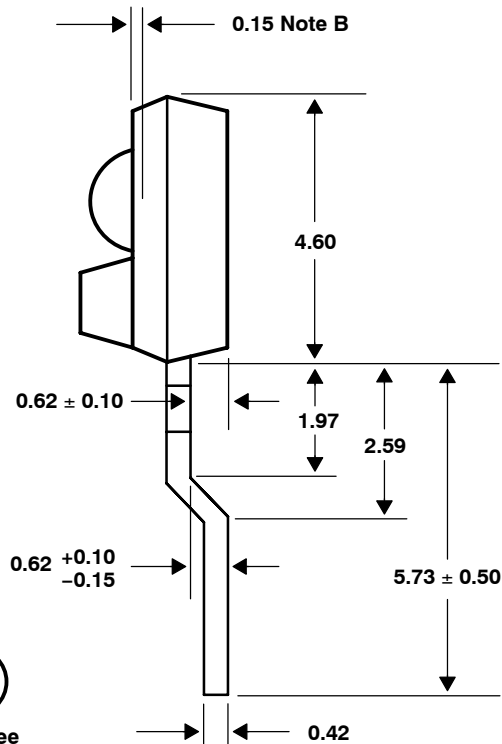

Lead Free

- NOTES: A. All linear dimensions are in millimeters; tolerance is  $\pm 0.25$  mm unless otherwise stated.  
 B. Dimension is to center of lens arc, which is located below the package face.  
 C. The integrated photodiode active area is typically located in the center of the lens and 0.97 mm below the top of the lens surface.  
 D. Index of refraction of clear plastic is 1.55.  
 E. Lead finish for TSL26xRSM-LF: solder dipped, 100% Sn.  
 F. This drawing is subject to change without notice.

Figure 15. Package SM — Surface Mount Side-Looker Package Configuration



# TSL260R, TSL261R, TSL262R INFRARED LIGHT-TO-VOLTAGE OPTICAL SENSORS

TAOS049E -SEPTEMBER 2007

**PRODUCTION DATA** — information in this document is current at publication date. Products conform to specifications in accordance with the terms of Texas Advanced Optoelectronic Solutions, Inc. standard warranty. Production processing does not necessarily include testing of all parameters.

## ***LEAD-FREE (Pb-FREE) and GREEN STATEMENT***

**Pb-Free (RoHS)** TAOS' terms *Lead-Free* or *Pb-Free* mean semiconductor products that are compatible with the current RoHS requirements for all 6 substances, including the requirement that lead not exceed 0.1% by weight in homogeneous materials. Where designed to be soldered at high temperatures, TAOS Pb-Free products are suitable for use in specified lead-free processes.

**Green (RoHS & no Sb/Br)** TAOS defines *Green* to mean Pb-Free (RoHS compatible), and free of Bromine (Br) and Antimony (Sb) based flame retardants (Br or Sb do not exceed 0.1% by weight in homogeneous material).

**Important Information and Disclaimer** The information provided in this statement represents TAOS' knowledge and belief as of the date that it is provided. TAOS bases its knowledge and belief on information provided by third parties, and makes no representation or warranty as to the accuracy of such information. Efforts are underway to better integrate information from third parties. TAOS has taken and continues to take reasonable steps to provide representative and accurate information but may not have conducted destructive testing or chemical analysis on incoming materials and chemicals. TAOS and TAOS suppliers consider certain information to be proprietary, and thus CAS numbers and other limited information may not be available for release.

## ***NOTICE***

Texas Advanced Optoelectronic Solutions, Inc. (TAOS) reserves the right to make changes to the products contained in this document to improve performance or for any other purpose, or to discontinue them without notice. Customers are advised to contact TAOS to obtain the latest product information before placing orders or designing TAOS products into systems.

TAOS assumes no responsibility for the use of any products or circuits described in this document or customer product design, conveys no license, either expressed or implied, under any patent or other right, and makes no representation that the circuits are free of patent infringement. TAOS further makes no claim as to the suitability of its products for any particular purpose, nor does TAOS assume any liability arising out of the use of any product or circuit, and specifically disclaims any and all liability, including without limitation consequential or incidental damages.

TEXAS ADVANCED OPTOELECTRONIC SOLUTIONS, INC. PRODUCTS ARE NOT DESIGNED OR INTENDED FOR USE IN CRITICAL APPLICATIONS IN WHICH THE FAILURE OR MALFUNCTION OF THE TAOS PRODUCT MAY RESULT IN PERSONAL INJURY OR DEATH. USE OF TAOS PRODUCTS IN LIFE SUPPORT SYSTEMS IS EXPRESSLY UNAUTHORIZED AND ANY SUCH USE BY A CUSTOMER IS COMPLETELY AT THE CUSTOMER'S RISK.

LUMENOLOGY, TAOS, the TAOS logo, and Texas Advanced Optoelectronic Solutions are registered trademarks of Texas Advanced Optoelectronic Solutions Incorporated.

# TSL260R, TSL261R, TSL262R INFRARED LIGHT-TO-VOLTAGE OPTICAL SENSORS

TAOS049E –SEPTEMBER 2007

---