

TOLERANCE UNLESS SPECIFIED = .XXX = +/- .005 .XX = +/- .015 FRACTIONS = +/- .032  
 TY-300P.DC2

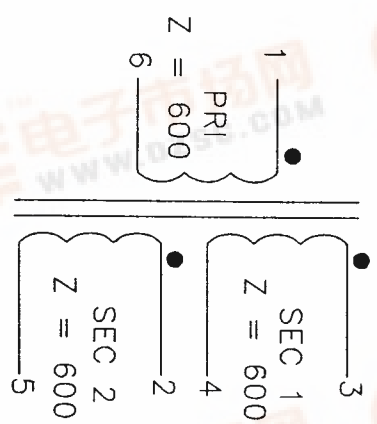
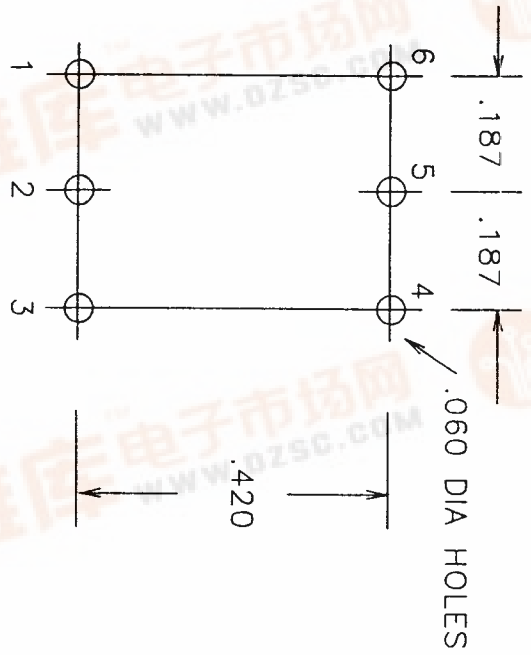
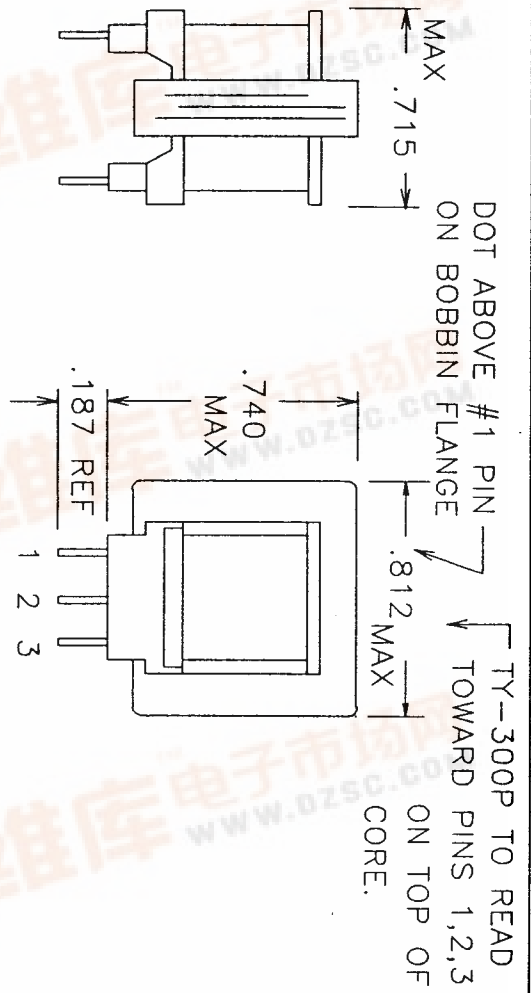

### PRODUCTION TESTS

TURNS RATIO = 100%	1-6 = 57 NOM
DC RESISTANCE IN OHMS	2-5 = 42 NOM
	3-4 = 42 NOM

APPLY = 2V, 400 HZ, 1-6  
 INDUCTANCE: 2.5 HY MIN

HIPOT = 1500V PRI TO SEC'S, CORE  
 500V SEC TO SEC  
 500V SEC'S TO CORE

IMPRREGNATION NOTES = PREHEAT 2 HRS  
 PINS TO BE FREE OF IMPREGNATION  
 FINAL ASSEMBLY NOTES

MagneTek

PART NO. TY-300P

METHOD 1 X 1

MARKING "TY-300P" ON TOP OF CORE  
 DATE & SITE CODE ON SIDE OF CORE

查询TY-300P供应商

捷多邦, 专业PCB打样工厂, 24小时加急出货