

## Features

- Supply Voltage up to 40 V
- $R_{DS(on)}$  Typically 0.5  $\Omega$  at 25°C, Maximum 1  $\Omega$  at 150°C
- Up to 1.5 A Output Current
- Three High-side and Three Low-side Drivers Usable as Single Outputs or Half Bridges
- Capable to Switch all Kinds of Loads such as DC Motors, Bulbs, Resistors, Capacitors and Inductors
- PWM Capability for Each Output Controlled by External PWM Signal
- No Shoot-through Current
- Very Low Quiescent Current  $I_S < 5 \mu A$  in Standby Mode over Total Temperature Range
- Outputs Short-circuit Protected
- Selective Overtemperature Protection for Each Switch and Overtemperature Prewarning
- Undervoltage Protection
- Various Diagnostic Functions such as Shorted Output, Open Load, Overtemperature and Power-supply Fail Detection
- Serial Data Interface, Daisy Chain Capable, up to 2 MHz Clock Frequency
- SO16 Power Package

## Description

The T6819/T6829 are fully protected driver interfaces designed in 0.8- $\mu m$  BCDMOS technology. They are used to control up to six different loads by a microcontroller in automotive and industrial applications.

Each of the three high-side and three low-side drivers is capable to drive currents up to 1.5 A. Each driver is freely configurable and can be controlled separately from a standard serial data interface. Therefore, all kinds of loads such as bulbs, resistors, capacitors and inductors can be combined. The IC design especially supports the applications of H-bridges to drive DC motors. The capability to control each output with an external PWM signal opens additional applications.

Protection is guaranteed regarding short-circuit conditions, overtemperature and undervoltage. Various diagnostic functions and a very low quiescent current in stand-by mode opens a wide range of applications. Automotive qualification (protection against conducted interferences, EMC protection and 2-kV ESD protection) gives added value and enhanced quality for exacting requirements of automotive applications.



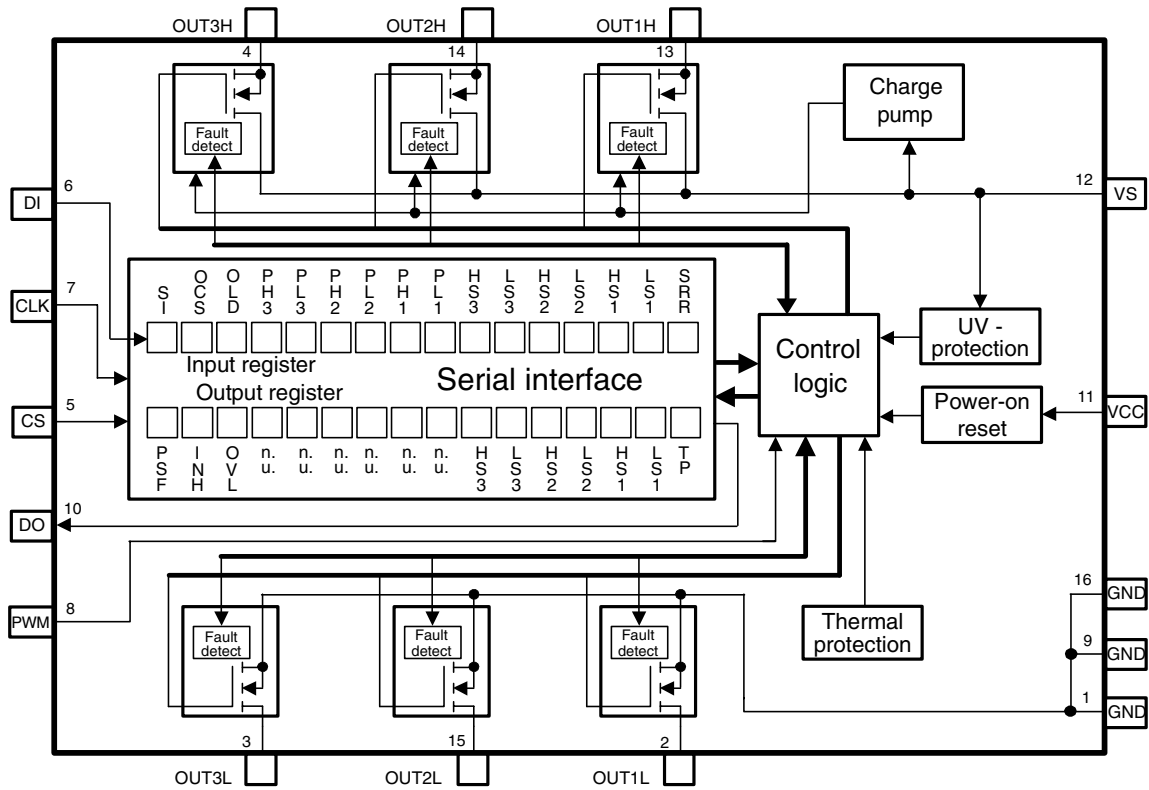
## Dual Triple DMOS Output Driver with Serial Input Control

### T6819/T6829

### Preliminary

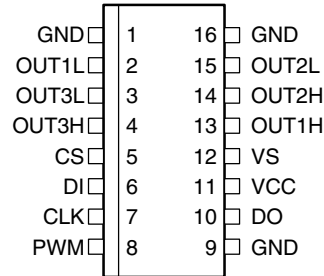


Figure 1. Block Diagram



## Pin Configuration

Figure 2. Pinning SO16



## Pin Description

Pin	Symbol	Function
1	GND	T6819: ground; reference potential; internal connection to pin 9 and pin 16; cooling tab T6829: additional connection to heat slug
2	OUT1L	Low-side driver output 1; power MOS open drain with internal reverse diode; short-circuit protection; overtemperature protection; diagnosis for short and open load; PWM ability
3	OUT3L	Low-side driver output 3; see pin 2
4	OUT3H	High-side driver output 3; power MOS open source with internal reverse diode; short-circuit protection; overtemperature protection; diagnosis for short and open load; PWM ability
5	CS	Chip select input; 5-V CMOS logic level input with internal pull up; low = serial communication is enabled, high = disabled
6	DI	Serial data input; 5-V CMOS logic level input with internal pull down; receives serial data from the control device; DI expects a 16-bit control word with LSB being transferred first
7	CLK	Serial clock input; 5-V CMOS logic level input with internal pull down; controls serial data input interface and internal shift register ( $f_{max} = 2$ MHz)
8	PWM	PWM input; 5-V CMOS logic level input with internal pull down; receives PWM signal to control outputs which are selected for PWM mode by the serial data interface, high = outputs on, low = outputs off
9	GND	Ground; see pin 1
10	DO	Serial data output; 5-V CMOS logic-level tristate output for output (status) register data; sends 16-bit status information to the microcontroller (LSB is transferred first); output will remain tristated unless device is selected by CS = low, therefore, several ICs can operate on one data-output line only.
11	VCC	Logic supply voltage (5 V)
12	VS	Power supply for high-side output stages OUT1H, OUT2H, OUT3H, internal supply
13	OUT1H	High-side driver output 1; see pin 4
14	OUT2H	High-side driver output 2; see pin 4
15	OUT2L	Low-side driver output 2; see pin 2
16	GND	Ground; see pin 1



## Functional Description

### Serial Interface

Data transfer starts with the falling edge of the CS signal. Data must appear at DI synchronized to CLK and are accepted on the falling edge of the CLK signal. LSB (bit 0, SRR) has to be transferred first. Execution of new input data is enabled on the rising edge of the CS signal. When CS is high, pin DO is in tristate condition. This output is enabled on the falling edge of CS. Output data will change their state with the rising edge of CLK and stay stable until the next rising edge of CLK appears. LSB (bit 0, TP) is transferred first.

Figure 3. Data Transfer

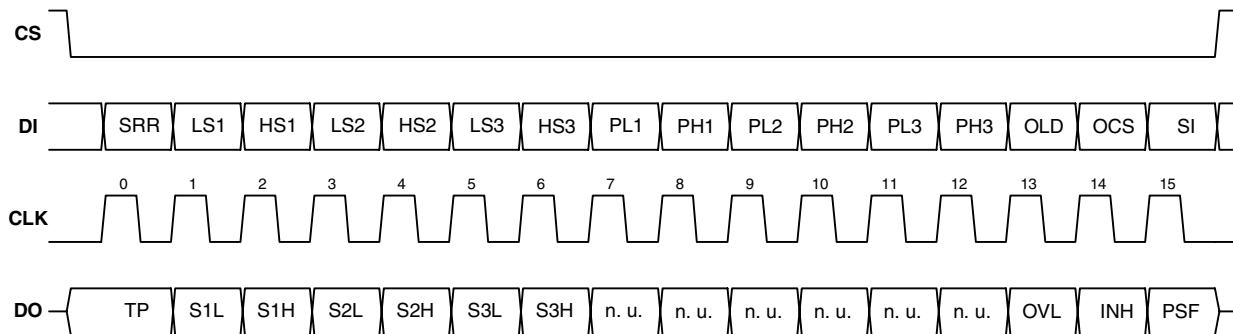


Table 1. Input Data Protocol

Bit	Input Register	Function
0	SRR	Status register reset (high = reset; the bits PSF and OVL in the output data register are set to low)
1	LS1	Controls output LS1 (high = switch output LS1 on)
2	HS1	Controls output HS1 (high = switch output HS1 on)
3	LS2	See LS1
4	HS2	See HS1
5	LS3	See LS1
6	HS3	See HS1
7	PL1	Output LS1 additionally controlled by PWM Input
8	PH1	Output HS1 additionally controlled by PWM Input
9	PL2	See PL1
10	PH2	See PH1
11	PL3	See PL1
12	PH3	See PH1
13	OLD	Open load detection (low = on)
14	OCS	Overcurrent shutdown (high = overcurrent shutdown is active)
15	SI	Software inhibit; low = standby, high = normal operation (data transfer is not affected by standby function because the digital part is still powered)

**Table 2.** Output Data Protocol

Bit	Output (Status) Register	Function
0	TP	Temperature prewarning: high = warning
1	Status LS1	Normal operation: high = output is on, low = output is off Open-load detection: high = open load, low = no open load (correct load condition is detected if the corresponding output is switched off); not affected by SRR
2	Status HS1	Normal operation: high = output is on, low = output is off Open-load detection: high = open load, low = no open load (correct load condition is detected if the corresponding output is switched off); not affected by SRR
3	Status LS2	Description see LS1
4	Status HS2	Description see HS1
5	Status LS3	Description see LS1
6	Status HS3	Description see HS1
7	n. u.	Not used
8	n. u.	Not used
9	n. u.	Not used
10	n. u.	Not used
11	n. u.	Not used
12	n. u.	Not used
13	OVL	Over-load detected: set high, when at least one output is switched off by a short-circuit condition or an overtemperature event. Bits 1 to 6 can be used to detect the affected switch. (open-load detection bit OLD = high)
14	INH	Inhibit: this bit is controlled by software (bit SI in input register) High = standby, low = normal operation
15	PSF	Power-supply fail: undervoltage at pin VS detected

After power-on reset, the input register has the following status:

Bit 15	Bit 14	Bit 13	Bit 12	Bit 11	Bit 10	Bit 9	Bit 8	Bit 7	Bit 6	Bit 5	Bit 4	Bit 3	Bit 2	Bit 1	Bit 0
SI	OCS	OLD	PH3	PL3	PH2	PL2	PH1	PL1	HS3	LS3	HS2	LS2	HS1	LS1	SRR
H	H	H	L	L	L	L	L	L	L	L	L	L	L	L	L

The following patterns are used to enable internal test modes of the IC. It is not recommended to use these patterns during normal operation.

Bit 15	Bit 14	Bit 13	Bit 12	Bit 11	Bit 10	Bit 9	Bit 8	Bit 7	Bit 6	Bit 5	Bit 4	Bit 3	Bit 2	Bit 1	Bit 0
		(OCS)							(HS3)	(LS3)	(HS2)	(LS2)	(HS1)	(LS1)	(SRR)
H	H	H	H	H	L	L	L	L	L	L	L	L	L	L	L
H	H	H	L	L	H	H	L	L	L	L	L	L	L	L	L
H	H	H	L	L	L	L	H	H	L	L	L	L	L	L	L



## Power-supply Fail

In case of undervoltage at pin VS, the Power-Supply Fail bit (PSF) in the output register is set and all outputs are disabled. To detect an undervoltage, its duration has to last longer than the undervoltage detection delay time  $t_{dUV}$ . The outputs are enabled immediately when supply voltage recovers normal operation value. The PSF bit stays high until it is reset by the SRR bit in the input register.

## Open-load Detection

If the open-load detection bit (OLD) is set to low, a pull-up current for each high-side switch and a pull-down current for each low-side switch is turned on (open-load detection current  $I_{OUT1-3}$ ). If the current through the external load does not reach the open-load detection current, the corresponding bit of the output in the output register is set to high.

Switching on an output stage with OLD bit set to low disables the open-load function for this output.

## Overtemperature Protection

If the junction temperature of one or more output stages exceeds the thermal prewarning threshold,  $T_{jPW\ set}$ , the temperature prewarning bit (TP) in the output register is set. When the temperature falls below the thermal prewarning threshold,  $T_{jPW\ reset}$ , the bit TP is reset. The TP bit can be read without transferring a complete 16-bit data word. The status of TP is available at pin DO with the falling edge of CS. After the microcontroller has read this information, CS is set high and the data transfer is interrupted without affecting the status of input and output registers.

If the junction temperature of an output stage exceeds the thermal shutdown threshold,  $T_{j\ switch\ off}$ , the affected output is disabled and the corresponding bit in the output register is set to low. Additionally the overload detection bit (OVL) in the output register is set. The output can be enabled again when the temperature falls below the thermal shutdown threshold,  $T_{j\ switch\ on}$  and the SRR bit in the input register is set to high. Hysteresis of thermal prewarning and shutdown threshold avoids oscillations.

## Short-circuit Protection

The output currents are limited by a current regulator. Overcurrent detection is activated by writing a high to the OCS bit in the input register. When the current in an output stage exceeds the overcurrent limitation and shut-down threshold, it is switched off after a delay time ( $t_{dSd}$ ). The over-load detection bit (OVL) is set and the corresponding status bit in the output register is set to low. For OCS = low the overcurrent shutdown is inactive and the OVL bit is not set by an overcurrent. By writing a high to the SRR bit in the input register the OVL bit is reset and the disabled outputs are enabled.

## Inhibit

The SI bit in the input register has to be set to zero to inhibit the T6819/T6829.

All output stages are then turned off but the serial interface stays active. The current consumption is reduced to less than 5  $\mu A$  at pin VS and less than 100  $\mu A$  at pin VCC. The output stages can be activated again by bit SI = 1.

## Absolute Maximum Ratings

Stresses beyond those listed under “Absolute Maximum Ratings” may cause permanent damage to the device. This is a stress rating only and functional operation of the device at these or any other conditions beyond those indicated in the operational sections of this specification is not implied. Exposure to absolute maximum rating conditions for extended periods may affect device reliability.

All values refer to GND pins.

Parameters	Pin	Symbol	Value	Unit
Supply voltage	12	$V_{VS}$	-0.3 to +40	V
Supply voltage $t < 0.5$ s; $I_S > -2$ A	12	$V_{VS}$	-1	V
Logic supply voltage	11	$V_{VCC}$	-0.3 to +7	V
Logic input voltage	5 to 8	$V_{CS}, V_{DI}, V_{CLK}, V_{PWM}$	-0.3 to $V_{VCC} + 0.3$	V
Logic output voltage	10	$V_{DO}$	-0.3 to $V_{VCC} + 0.3$	V
Input current	5 to 8	$I_{CS}, I_{DI}, I_{CLK}, I_{PWM}$	-10 to +10	mA
Output current	10	$I_{DO}$	-10 to +10	mA
Output current	2 to 4 13 to 15	$I_{Out3H}, I_{Out2H}, I_{Out1H}$ $I_{Out3L}, I_{Out2L}, I_{Out1L}$	Internally limited, see output specification	
Output voltage	2 to 4 13 to 15	$I_{Out3H}, I_{Out2H}, I_{Out1H}$ $I_{Out3L}, I_{Out2L}, I_{Out1L}$	-0.3 to +40	V
Reverse conducting current ( $t_{pulse} = 150$ $\mu$ s)	2 to 4 13 to 15 towards pin 12	$I_{Out3H}, I_{Out2H}, I_{Out1H}$ $I_{Out3L}, I_{Out2L}, I_{Out1L}$	17	A
Junction temperature range		$T_J$	-40 to +150	$^{\circ}$ C
Storage temperature range		$T_{STG}$	-55 to +150	$^{\circ}$ C

## Thermal Resistance

Parameters	Test Conditions	Symbol	Value	Unit
<b>T6819</b>				
Junction pin	Measured to GND Pins 1, 9 and 16	$R_{thJP}$	30	K/W
Junction ambient		$R_{thJA}$	65	K/W
<b>T6829</b>				
Junction pin	Measured to heat slug GND pins 1, 9 and 16	$R_{thJP}$	5	K/W
Junction ambient		$R_{thJA}$	30	K/W

## Operating Range

Parameters	Symbol	Value	Unit
Supply voltage	$V_{VS}$	$V_{UV}^{(1)}$ to 40	V
Logic supply voltage	$V_{VCC}$	4.75 to 5.25	V
Logic input voltage	$V_{CS}, V_{DI}, V_{CLK}, V_{PWM}$	-0.3 to $V_{VCC}$	V
Serial interface clock frequency	$f_{CLK}$	2	MHz
PWM input frequency	$f_{PWM}$	1	kHz
Junction temperature range	$T_j$	-40 to +150	$^{\circ}$ C

Note: 1. Threshold for undervoltage detection.



## Noise and Surge Immunity

Parameters	Test Conditions	Value
Conducted interferences	ISO 7637-1	Level 4 <sup>(1)</sup>
Interference suppression	VDE 0879 Part 2	Level 5
ESD (Human Body Model)	ESD S 5.1	2 kV
ESD (Machine Model)	JEDEC A115A	200 V

Note: 1. Test pulse 5:  $V_{smax} = 40$  V.

## Electrical Characteristics

7.5 V <  $V_S$  < 40 V; 4.75 V <  $V_{CC}$  < 5.25 V; INH = High; -40°C <  $T_j$  < 150°C; unless otherwise specified, all values refer to GND pins.

No.	Parameters	Test Conditions	Pin	Symbol	Min.	Typ.	Max.	Unit	Type*
<b>1</b>	<b>Current Consumption</b>								
1.1	Quiescent current VS	$V_{VS} < 20$ V, SI = low	12	$I_{VS}$		1	5	$\mu$ A	A
1.2	Quiescent current VCC	4.75 V < $V_{VCC} < 5.25$ V, SI = low	11	$I_{VCC}$		60	100	$\mu$ A	A
1.3	Supply current VS	$V_{VS} < 20$ V normal operating, all outputs off, input register bit 13 (OLD) = high	12	$I_{VS}$		4	6	mA	A
1.4	Supply current VCC	4.75 V < $V_{VCC} < 5.25$ V, normal operating	11	$I_{VCC}$		350	650	$\mu$ A	A
1.5	Discharge current VS	$V_{VS} = 32.5$ V, INH = low	12	$I_{VS}$	0.5		5.5	mA	A
1.6	Discharge current VS	$V_{VS} = 40$ V, INH = low	12	$I_{VS}$	2.5		10	mA	A
<b>2</b>	<b>Undervoltage Detection, Power-on Reset</b>								
2.1	Power-on reset threshold		11	$V_{VCC}$	3.2	3.9	4.4	V	A
2.2	Power-on reset delay time	After switching on $V_{CC}$		$t_{dPor}$	30	95	190	$\mu$ s	A
2.3	Undervoltage-detection threshold	$V_{CC} = 5$ V	12	$V_{UV}$	5.6		7.0	V	A
2.4	Undervoltage-detection hysteresis	$V_{CC} = 5$ V	12	$\Delta V_{UV}$		0.6		V	A
2.5	Undervoltage-detection delay time			$t_{dUV}$	10		40	$\mu$ s	A
<b>3</b>	<b>Thermal Prewarning and Shutdown</b>								
3.1	Thermal prewarning set			$T_{jPW\ set}$	120	145	170	°C	B
3.2	Thermal prewarning reset			$T_{jPW\ reset}$	105	130	155	°C	B
3.3	Thermal prewarning hysteresis			$\Delta T_{jPW}$		15		K	B
3.4	Thermal shutdown off			$T_{j\ switch\ off}$	150	175	200	°C	B

\*) Type means: A = 100% tested, B = 100% correlation tested, C = Characterized on samples, D = Design parameter

- Note:
1. Delay time between rising edge of input signal at pin CS after data transmission and switch on/off output stages to 90% of final level. Device not in standby for  $t > 1$  ms.
  2. Delay time between rising/falling edge of input signal at pin PWM and switch on/off output stages to 90% of final level.
  3. Difference between switch-on and switch-off delay time of input signal at pin PWM to output stages in PWM mode.



## Electrical Characteristics (Continued)

7.5 V < V<sub>S</sub> < 40 V; 4.75 V < V<sub>CC</sub> < 5.25 V; INH = High; -40°C < T<sub>j</sub> < 150°C; unless otherwise specified, all values refer to GND pins.

No.	Parameters	Test Conditions	Pin	Symbol	Min.	Typ.	Max.	Unit	Type*
3.5	Thermal shutdown on			T <sub>j switch on</sub>	135	160	185	°C	B
3.6	Thermal shutdown hysteresis			ΔT <sub>j switch off</sub>		15		K	B
3.7	Ratio thermal shutdown off/thermal prewarning set			T <sub>j switch off</sub> / T <sub>jPW set</sub>	1.05	1.2			B
3.8	Ratio thermal shutdown on/thermal prewarning reset			T <sub>j switch on</sub> / T <sub>jPW reset</sub>	1.05	1.2			B
<b>4</b>	<b>Output Specification (OUT1-OUT3)</b>								
4.1	On resistance	I <sub>Out 1-3 H</sub> = -1.3 A	4, 13, 14	R <sub>DS On 1-3 H</sub>			1.1	Ω	A
4.2		I <sub>Out 1-3 L</sub> = 1.3 A	2, 3, 15	R <sub>DS On 1-3 L</sub>			1.1	Ω	A
4.3	High-side output leakage current	V <sub>Out 1-3 H</sub> = 0 V, output stages off	4, 13, 14	I <sub>Out 1-3 H</sub>	-5			μA	A
4.4	Low-side output leakage current	V <sub>Out 1-3 L</sub> = V <sub>VS</sub> , output stages off	2, 3, 15	I <sub>Out 1-3 L</sub>			5	μA	A
4.5	High-side switch reverse diode forward voltage	I <sub>Out</sub> = 1.5 A	4, 13, 14	V <sub>Out 1-3</sub> - V <sub>VS</sub>			1.5	V	A
4.6	Low-side switch reverse diode forward voltage	I <sub>Out 1-3 L</sub> = -1.5 A	2, 3, 15	V <sub>Out 1-3 L</sub>	-1.5			V	A
4.7	High-side overcurrent limitation and shutdown threshold		4, 13, 14	I <sub>Out 1-3 H</sub>	-2.5	-2	-1.5	A	A
4.8	Low-side overcurrent limitation and shutdown threshold		2, 3, 15	I <sub>Out 1-3 L</sub>	1.5	2	2.5	A	A
4.9	Overcurrent shutdown delay time			t <sub>dSd</sub>	10		40	μs	A
4.10	High-side open load detection current	Input register bit 13 (OLD) = low, output off	4, 13, 14	I <sub>Out 1-3 H</sub>	-2.5		-0.2	mA	A
4.11	Low-side open load detection current	Input register bit 13 (OLD) = low, output off	2, 3, 15	I <sub>Out 1-3 L</sub>	0.2		2.5	mA	A
4.12	High-side output switch on delay <sup>(1),(2)</sup>	V <sub>VS</sub> = 13 V R <sub>Load</sub> = 30 Ω		t <sub>don</sub>			20	μs	A
4.13	Low-side output switch on delay <sup>(1),(2)</sup>	V <sub>VS</sub> = 13 V R <sub>Load</sub> = 30 Ω		t <sub>don</sub>			20	μs	A
4.14	High-side output switch off delay <sup>(1),(2)</sup>	V <sub>VS</sub> = 13 V R <sub>Load</sub> = 30 Ω		t <sub>doff</sub>			20	μs	A

\*) Type means: A = 100% tested, B = 100% correlation tested, C = Characterized on samples, D = Design parameter

- Note:
1. Delay time between rising edge of input signal at pin CS after data transmission and switch on/off output stages to 90% of final level. Device not in standby for t > 1 ms.
  2. Delay time between rising/falling edge of input signal at pin PWM and switch on/off output stages to 90% of final level.
  3. Difference between switch-on and switch-off delay time of input signal at pin PWM to output stages in PWM mode.



## Electrical Characteristics (Continued)

7.5 V < V<sub>S</sub> < 40 V; 4.75 V < V<sub>CC</sub> < 5.25 V; INH = High; -40°C < T<sub>j</sub> < 150°C; unless otherwise specified, all values refer to GND pins.

No.	Parameters	Test Conditions	Pin	Symbol	Min.	Typ.	Max.	Unit	Type*
4.15	Low-side output switch off delay <sup>(1),(2)</sup>	V <sub>VS</sub> = 13 V R <sub>Load</sub> = 30 Ω		t <sub>doff</sub>			3	μs	A
4.16	Dead time between corresponding high- and low-side switches	V <sub>VS</sub> = 13 V R <sub>Load</sub> = 30 Ω		t <sub>don</sub> - t <sub>doff</sub>	1			μs	A
4.17	Δt <sub>dPWM</sub> low-side switch <sup>(3)</sup>	V <sub>VS</sub> = 13 V R <sub>Load</sub> = 30 Ω		Δt <sub>dPWM</sub> = t <sub>don</sub> - t <sub>doff</sub>			20	μs	A
4.18	Δt <sub>dPWM</sub> high-side switch <sup>(3)</sup>	V <sub>VS</sub> = 13 V R <sub>Load</sub> = 30 Ω		Δt <sub>dPWM</sub> = t <sub>don</sub> - t <sub>doff</sub>	3		7	μs	A
<b>5</b>	<b>Logic Inputs DI, CLK, CS, PWM</b>								
5.1	Input voltage low-level threshold		5-8	V <sub>IL</sub>	0.3 × V <sub>VCC</sub>			V	A
5.2	Input voltage high-level threshold		5-8	V <sub>IH</sub>			0.7 × V <sub>VCC</sub>	V	A
5.3	Hysteresis of input voltage		5-8	ΔV <sub>I</sub>	50		700	mV	A
5.4	Pull-down current Pins DI, CLK, PWM	V <sub>DI</sub> , V <sub>CLK</sub> , V <sub>PWM</sub> = V <sub>CC</sub>	6, 7, 8	I <sub>PD</sub>	10		65	μA	A
5.5	Pull-up current Pin CS	V <sub>CS</sub> = 0 V	5	I <sub>PU</sub>	-65		-10	μA	A
<b>6</b>	<b>Serial Interface – Logic Output DO</b>								
6.1	Output-voltage low level	I <sub>DO</sub> L = 2 mA	10	V <sub>DO</sub> L			0.4	V	A
6.2	Output-voltage high level	I <sub>DO</sub> L = -2 mA	10	V <sub>DO</sub> H	V <sub>VCC</sub> - 0.7 V			V	A
6.3	Leakage current (tristate)	V <sub>CS</sub> = V <sub>CC</sub> 0V < V <sub>DO</sub> < V <sub>VCC</sub>	10	I <sub>DO</sub>	-10		10	μA	A
<b>7</b>	<b>Inhibit Input – Timing</b>								
7.1	Delay time from standby to normal operation			t <sub>dINH</sub>			100	μs	A

\*) Type means: A = 100% tested, B = 100% correlation tested, C = Characterized on samples, D = Design parameter

- Note:
1. Delay time between rising edge of input signal at pin CS after data transmission and switch on/off output stages to 90% of final level. Device not in standby for t > 1 ms.
  2. Delay time between rising/falling edge of input signal at pin PWM and switch on/off output stages to 90% of final level.
  3. Difference between switch-on and switch-off delay time of input signal at pin PWM to output stages in PWM mode.

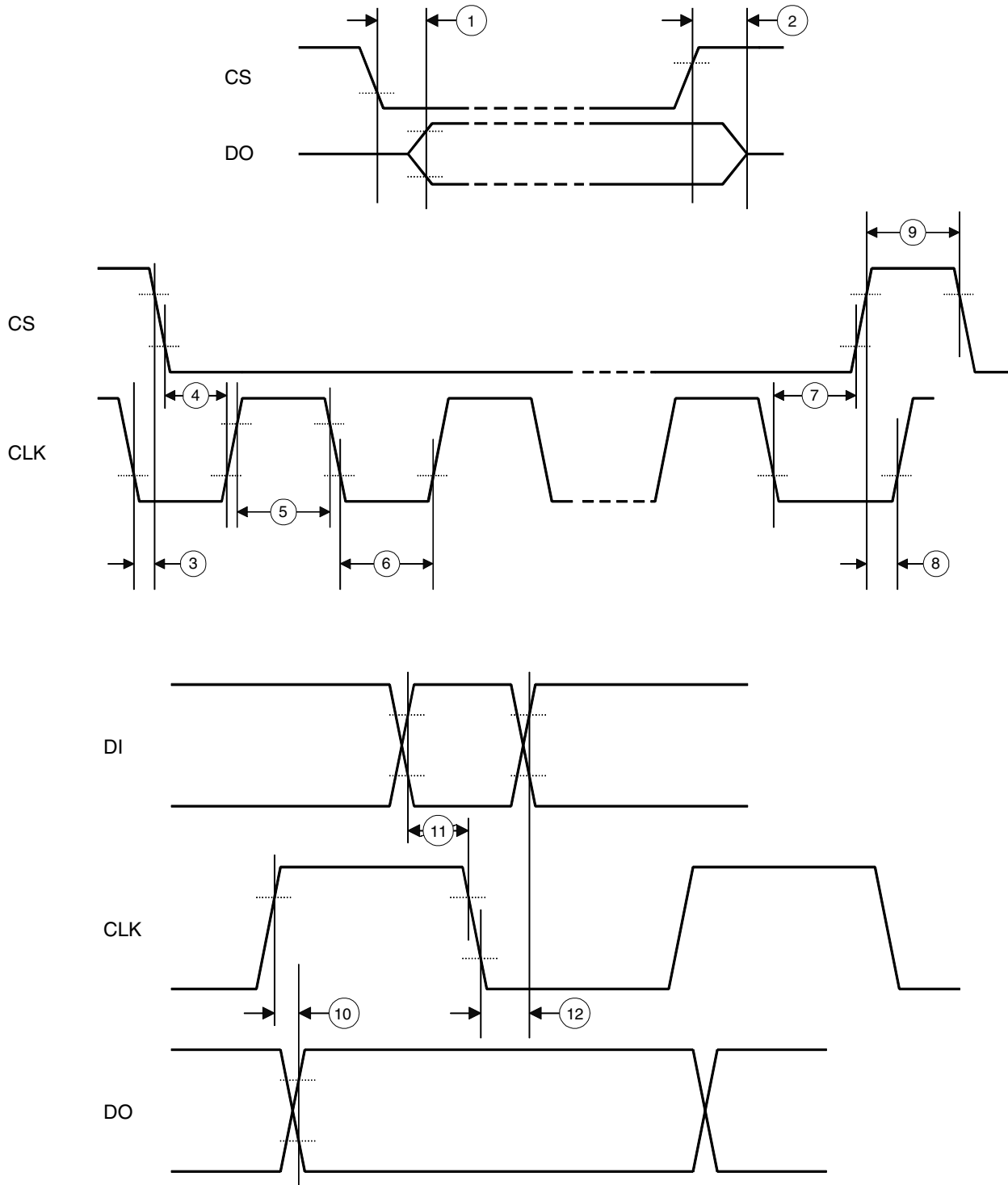
## Serial Interface – Timing

No.	Parameters	Test Conditions	Pin	Timing Chart No. <sup>(1)</sup>	Symbol	Min.	Typ.	Max.	Unit	Type*
8.1	DO enable after CS falling edge	$C_{DO} = 100 \text{ pF}$	10	1	$t_{\text{ENDO}}$			200	ns	D
8.2	DO disable after CS rising edge	$C_{DO} = 100 \text{ pF}$	10	2	$t_{\text{DISDO}}$			200	ns	D
8.3	DO fall time	$C_{DO} = 100 \text{ pF}$	10	-	$t_{\text{DOF}}$			100	ns	D
8.4	DO rise time	$C_{DO} = 100 \text{ pF}$	10	-	$t_{\text{DOR}}$			100	ns	D
8.5	DO valid time	$C_{DO} = 100 \text{ pF}$	10	10	$t_{\text{DOVal}}$			200	ns	D
8.6	CS setup time		5	4	$t_{\text{CSSethl}}$	225			ns	D
8.7	CS setup time		5	8	$t_{\text{CSSethh}}$	225			ns	D
8.8	CS high time		5	9	$t_{\text{CSH}}$	500			ns	D
8.9	CLK high time		7	5	$t_{\text{CLKh}}$	225			ns	D
8.10	CLK low time		7	6	$t_{\text{CLKl}}$	225			ns	D
8.11	CLK period time		7	-	$t_{\text{CLKp}}$	500			ns	D
8.12	CLK setup time		7	7	$t_{\text{CLKsethl}}$	225			ns	D
8.13	CLK setup time		7	3	$t_{\text{CLKsethh}}$	225			ns	D
8.14	DI setup time		6	11	$t_{\text{DIset}}$	40			ns	D
8.15	DI hold time		6	12	$t_{\text{DIHold}}$	40			ns	D

\*) Type means: A =100% tested, B = 100% correlation tested, C = Characterized on samples, D = Design parameter

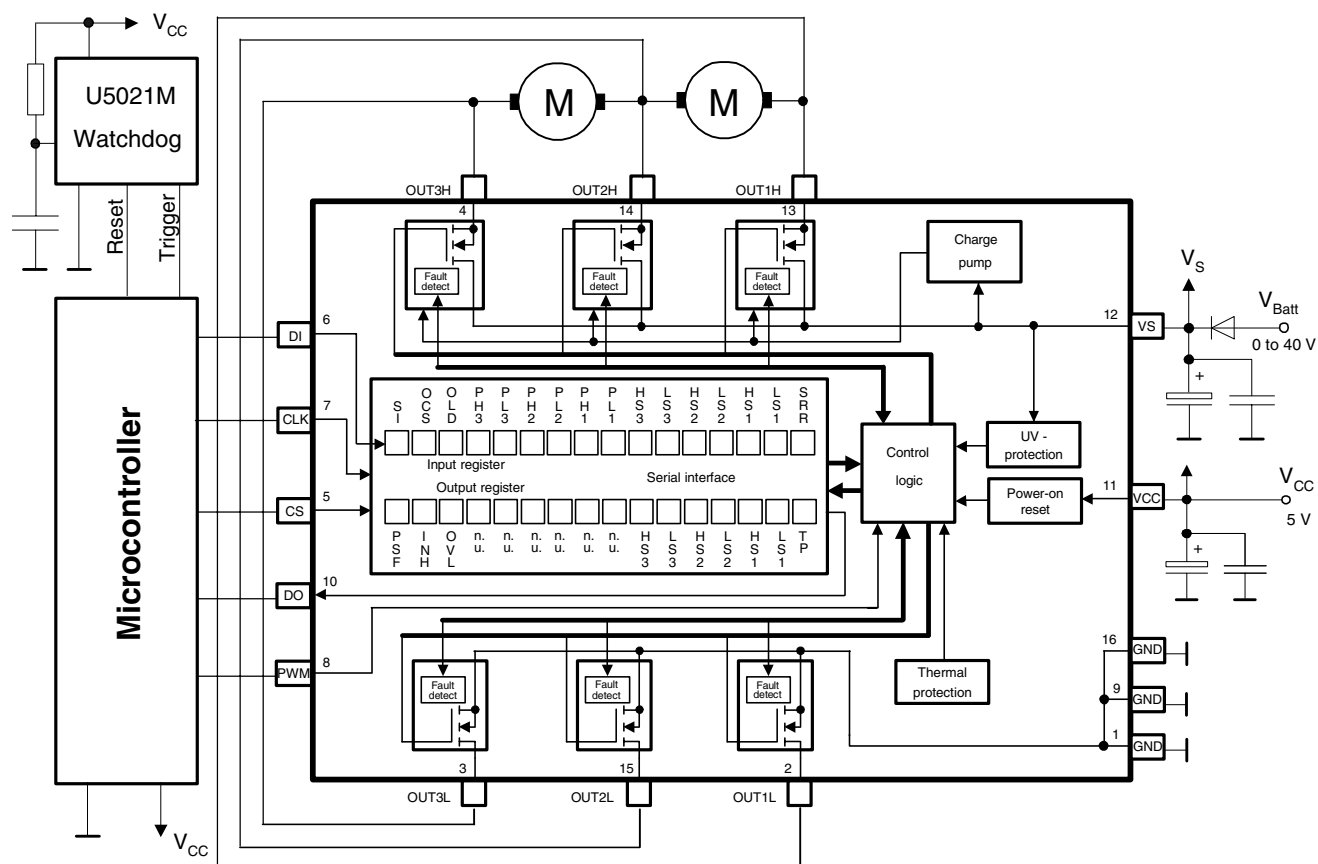
Note: 1. See Figure 4 on page 12

**Figure 4. Serial Interface Timing with Chart Number**



Inputs DI, CLK, CS: High level =  $0.7 \times V_{CC}$ , low level =  $0.3 \times V_{CC}$   
 Output DO: High level =  $0.8 \times V_{CC}$ , low level =  $0.2 \times V_{CC}$

## Application Circuit



## Application Notes

It is strongly recommended to connect the blocking capacitors at  $V_{CC}$  and  $V_S$  as close as possible to the power supply and GND pins.

Recommended value for capacitors at  $V_S$ :

Electrolytic capacitor  $C > 22 \mu\text{F}$  in parallel with a ceramic capacitor  $C = 100 \text{ nF}$ . Value for electrolytic capacitor depends on external loads, conducted interferences and reverse conducting current  $I_{\text{Out1,2,3}}$  (see "Absolute Maximum Ratings" on page 7).

Recommended value for capacitors at  $V_{CC}$ :

Electrolytic capacitor  $C > 10 \mu\text{F}$  in parallel with a ceramic capacitor  $C = 100 \text{ nF}$ .

To reduce thermal resistance it is recommended to place cooling areas on the PCB as close as possible to the GND pins.

Negative spikes at the output pins (e.g. negative spikes caused by an inductive load switched off with a high side driver) may activate the overtemperature protection function of the T6819/T6829. In this condition, the affected output will be switched off. If this behavior is not acceptable or compatible with the specific application functionally, it is necessary, that for switching on required outputs again, the SRR bit (**S**tatus **R**eset) is set, to ensure a reset of the overtemperature function.

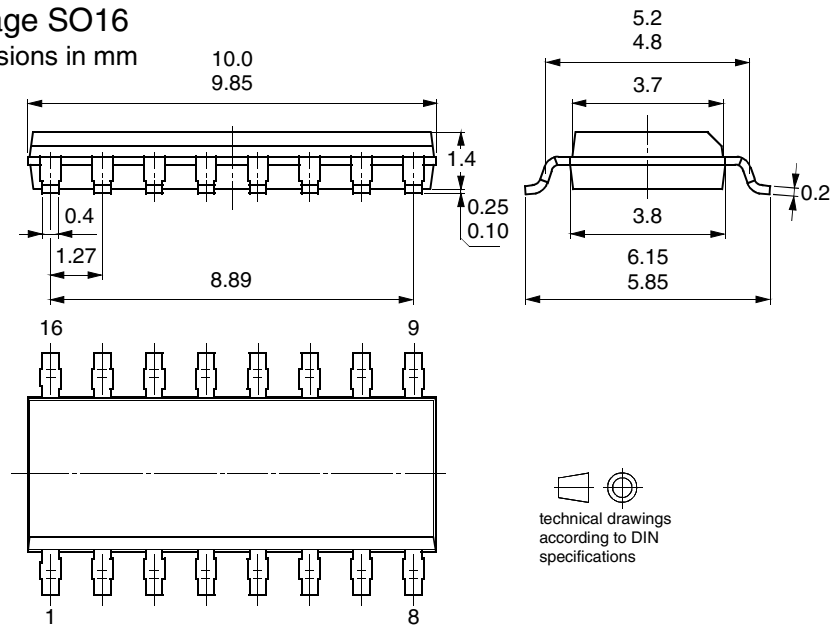


## Ordering Information

Extended Type Number	Package	Remarks
T6819-TBS	SO16	Power package, tubed
T6819-TBQ	SO16	Power package, taped and reeled
T6829-TBS	SO16	Power package with heat slug, tubed
T6829-TBQ	SO16	Power package with heat slug, taped and reeled

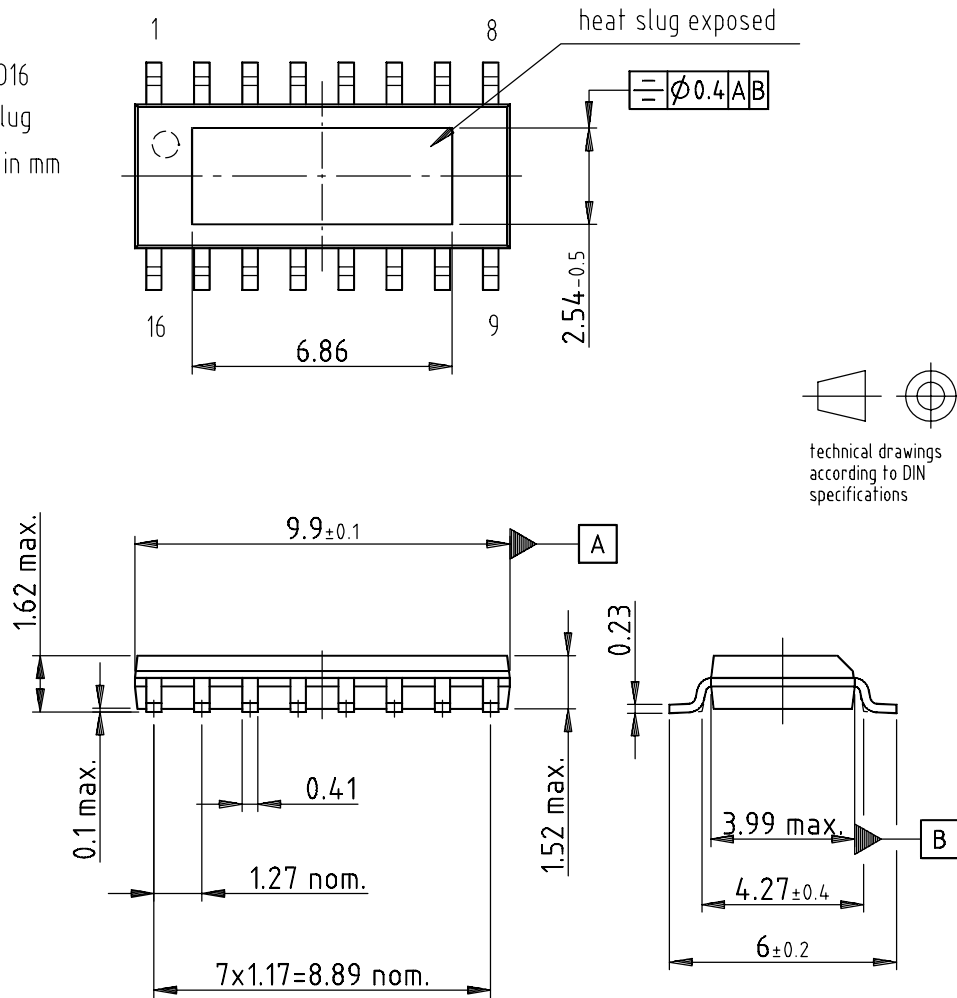
## Package Information

Package SO16  
Dimensions in mm



# T6819/T6829 [Preliminary]

Package: S016  
with heat slug  
Dimensions in mm



technical drawings  
according to DIN  
specifications

Drawing-No.: 6.541-5050.01-4  
Issue: 1; 25.02.02

CEI-Package



## Atmel Corporation

2325 Orchard Parkway  
San Jose, CA 95131, USA  
Tel: 1(408) 441-0311  
Fax: 1(408) 487-2600

## Regional Headquarters

### Europe

Atmel Sarl  
Route des Arsenaux 41  
Case Postale 80  
CH-1705 Fribourg  
Switzerland  
Tel: (41) 26-426-5555  
Fax: (41) 26-426-5500

### Asia

Room 1219  
Chinachem Golden Plaza  
77 Mody Road Tsimshatsui  
East Kowloon  
Hong Kong  
Tel: (852) 2721-9778  
Fax: (852) 2722-1369

### Japan

9F, Tonetsu Shinkawa Bldg.  
1-24-8 Shinkawa  
Chuo-ku, Tokyo 104-0033  
Japan  
Tel: (81) 3-3523-3551  
Fax: (81) 3-3523-7581

## Atmel Operations

### Memory

2325 Orchard Parkway  
San Jose, CA 95131, USA  
Tel: 1(408) 441-0311  
Fax: 1(408) 436-4314

### Microcontrollers

2325 Orchard Parkway  
San Jose, CA 95131, USA  
Tel: 1(408) 441-0311  
Fax: 1(408) 436-4314

La Chantrerie  
BP 70602  
44306 Nantes Cedex 3, France  
Tel: (33) 2-40-18-18-18  
Fax: (33) 2-40-18-19-60

### ASIC/ASSP/Smart Cards

Zone Industrielle  
13106 Rousset Cedex, France  
Tel: (33) 4-42-53-60-00  
Fax: (33) 4-42-53-60-01

1150 East Cheyenne Mtn. Blvd.  
Colorado Springs, CO 80906, USA  
Tel: 1(719) 576-3300  
Fax: 1(719) 540-1759

Scottish Enterprise Technology Park  
Maxwell Building  
East Kilbride G75 0QR, Scotland  
Tel: (44) 1355-803-000  
Fax: (44) 1355-242-743

### RF/Automotive

Theresienstrasse 2  
Postfach 3535  
74025 Heilbronn, Germany  
Tel: (49) 71-31-67-0  
Fax: (49) 71-31-67-2340

1150 East Cheyenne Mtn. Blvd.  
Colorado Springs, CO 80906, USA  
Tel: 1(719) 576-3300  
Fax: 1(719) 540-1759

### Biometrics/Imaging/Hi-Rel MPU/ High Speed Converters/RF Datacom

Avenue de Rochepleine  
BP 123  
38521 Saint-Egreve Cedex, France  
Tel: (33) 4-76-58-30-00  
Fax: (33) 4-76-58-34-80

---

### Literature Requests

[www.atmel.com/literature](http://www.atmel.com/literature)

**Disclaimer:** Atmel Corporation makes no warranty for the use of its products, other than those expressly contained in the Company's standard warranty which is detailed in Atmel's Terms and Conditions located on the Company's web site. The Company assumes no responsibility for any errors which may appear in this document, reserves the right to change devices or specifications detailed herein at any time without notice, and does not make any commitment to update the information contained herein. No licenses to patents or other intellectual property of Atmel are granted by the Company in connection with the sale of Atmel products, expressly or by implication. Atmel's products are not authorized for use as critical components in life support devices or systems.

© Atmel Corporation 2003. All rights reserved.

Atmel® and combinations thereof are the registered trademarks of Atmel Corporation or its subsidiaries.

Other terms and product names may be the trademarks of others.



Printed on recycled paper.