



UDA1431T

16-bit, 48 kHz, low-cost stereo current DAC

Rev. 04 — 30 May 2006

Product data sheet

1. General description

The UDA1431T is a 16-bit, 48 kHz, single-chip stereo DAC employing bitstream conversion techniques.

The UDA1431T supports the I²S-bus data format with word lengths of up to 24 bits, MSB justified and can be operated with a 256f_s master clock mode.

The audio outputs meet the IEC 61938 specification.

2. Features

- Low power consumption
- Analog power supply voltage from 10.8 V to 13.2 V
- Digital power supply voltage from 3.1 V to 3.5 V
- Master clock frequencies of 256f_s
- Supports sampling frequencies up to 48 kHz
- Integrated digital filter
- No analog post filtering required for DAC
- Slave mode only applications
- I²S-bus input interface: 16-bit, 18-bit, 20-bit and 24-bit format compatible
- CMOS levels compatible digital inputs and outputs
- Very easy application
- Advanced audio configuration:
 - ◆ Stereo line output
 - ◆ High linearity, wide dynamic range and low distortion
- Small package size (SO14)

3. Applications

- PC audio applications
- Car radio applications
- DVD players
- Digital set-top boxes

4. Quick reference data

Table 1. Quick reference data

$V_{DDA} = 12.0\text{ V}$; $V_{DDD} = 3.3\text{ V}$; $T_{amb} = 25\text{ °C}$; $f_s = 48\text{ kHz}$; $f_i = 1\text{ kHz}$; all voltages referenced to ground (pins V_{SSA} and V_{SSD}); unless otherwise specified.

Symbol	Parameter	Conditions	Min	Typ	Max	Unit	
Supplies							
V_{DDA}	analog supply voltage (for DAC)		10.8	12.0	13.2	V	
V_{DDD}	digital supply voltage		3.1	3.3	3.5	V	
I_{DDA}	analog supply current (for DAC)	$V_{DDA} = 12.0\text{ V}$					
		operating	[1]	-	6.6	-	mA
		power-down	-	-	0.8	-	mA
I_{DDD}	digital supply current	$V_{DDD} = 3.3\text{ V}$					
		operating	[1]	-	7.0	-	mA
		power-down	-	-	6.8	-	mA
P_{tot}	total power dissipation	operating	[1]	-	102	-	mW
T_{amb}	ambient temperature		5	-	65	°C	
Digital-to-analog converter							
$V_{o(rms)}$	output voltage (RMS value)		1.575	1.880	1.925	V	
(THD + N)/S	total harmonic distortion-plus-noise to signal ratio	at 0 dB	[2][3]	-62	-66	-	dB
		at -60 dB	[2][4]	-	-32.5	-	dB
S/N	signal-to-noise ratio		[3][5]	89	94	-	dB
α_{cs}	channel separation	at 0 dB; from 1 kHz to 20 kHz		85	98	-	dB

[1] A 1 kHz at 0 dB sine wave input is applied.

[2] (THD + N)/S is the power ratio between the sum of noise and distortion and the output signal.

[3] Measurement is performed with a 22 kHz low-pass filter and is unweighted.

[4] Measurement is performed with a ITU-R-2K filter and is unweighted.

[5] S/N is the power ratio between the output signal and the noise measured with no signal applied.

5. Ordering information

Table 2. Ordering information

Type number	Package		
	Name	Description	Version
UDA1431T	SO14	plastic small outline package; 14 leads; body width 3.9 mm	SOT108-1

6. Block diagram

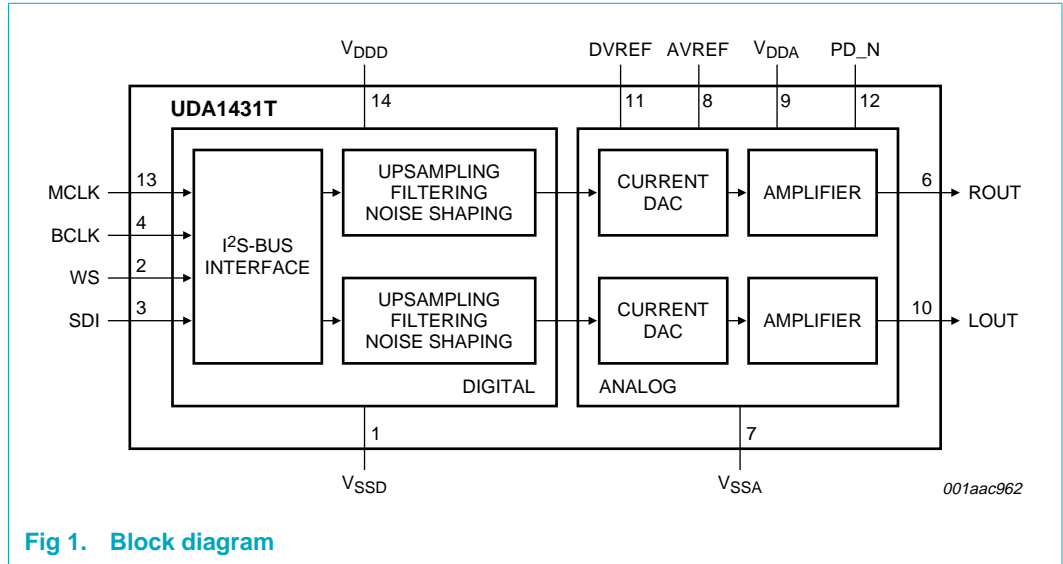

7. Pinning information

7.1 Pinning

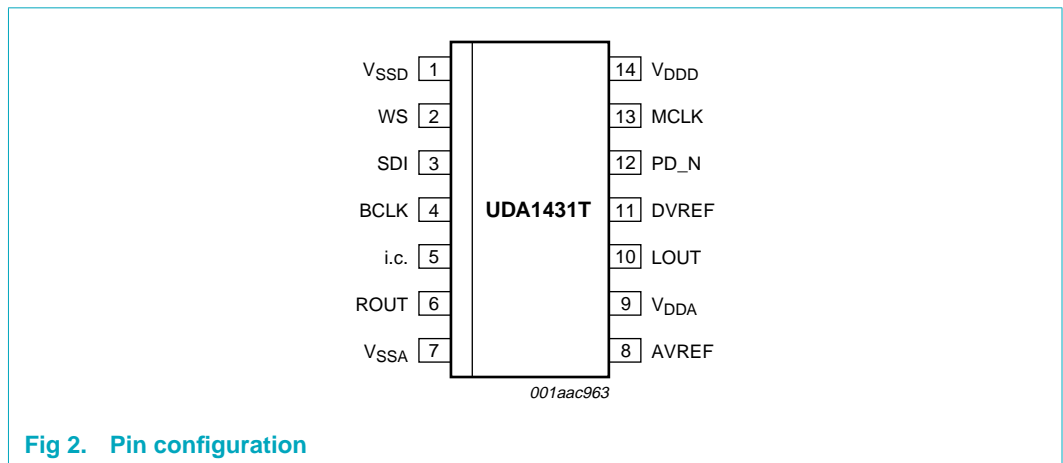

7.2 Pin description

Table 3. Pin description

Symbol	Pin	Description
V _{SSD}	1	digital ground
WS	2	word select input
SDI	3	serial audio data input
BCLK	4	bit clock input
i.c.	5	internally connected; do not connect or connect to V _{DD}

Table 3. Pin description ...continued

Symbol	Pin	Description
ROUT	6	right channel output
V _{SSA}	7	analog ground (for DAC)
AVREF	8	regulator decoupling
V _{DDA}	9	analog supply voltage (for DAC)
LOUT	10	left channel output
DVREF	11	internal reference voltage (digital part)
PD_N	12	power-down input (active LOW)
MCLK	13	master clock input (256f _s)
V _{DDD}	14	digital supply voltage

8. Functional description

8.1 Master clock

The UDA1431T operates in slave mode only. Therefore, in all applications the system devices must provide a master clock (pin MCLK) at 256f_s for correct operation. The master clock must be locked in frequency to the digital interface input signals.

The UDA1431T supports sampling frequencies up to 48 kHz.

8.2 Data formats

The I²S-bus formats are shown in [Figure 3](#).

Left and right data channel words are time multiplexed.

The UDA1431T supports I²S-bus formats with data word length up to 24 bits.

The BCLK clock can be up to 48f_s, or in other words the BCLK frequency is 48 times or less the word select frequency (pin WS): $f_{\text{BCLK}} \leq 48 \times f_{\text{WS}}$.

Important: The WS edge MUST fall on the negative edge of the BCLK at all times for proper operation of the digital interface.

8.3 Noise shaper

The 1st-order noise shaper operates at 32f_s. It shifts in-band quantization noise to frequencies well above the audio band. This noise shaping technique enables high signal-to-noise ratios to be achieved. The noise shaper output is converted into an analog signal using a current DAC.

8.4 Reset

After turning on the power supplies of the device, the device must be reset. This is done by applying a logic 0 pulse on PD_N (pin 12) during at least 8 full MCLK periods. If PD_N (pin 12) has a value of logic 0 at start-up, it must be set to logic 1 only after 8 full MCLK periods. The device is ready to receive audio data only after 128 MCLK periods from the end of the reset.

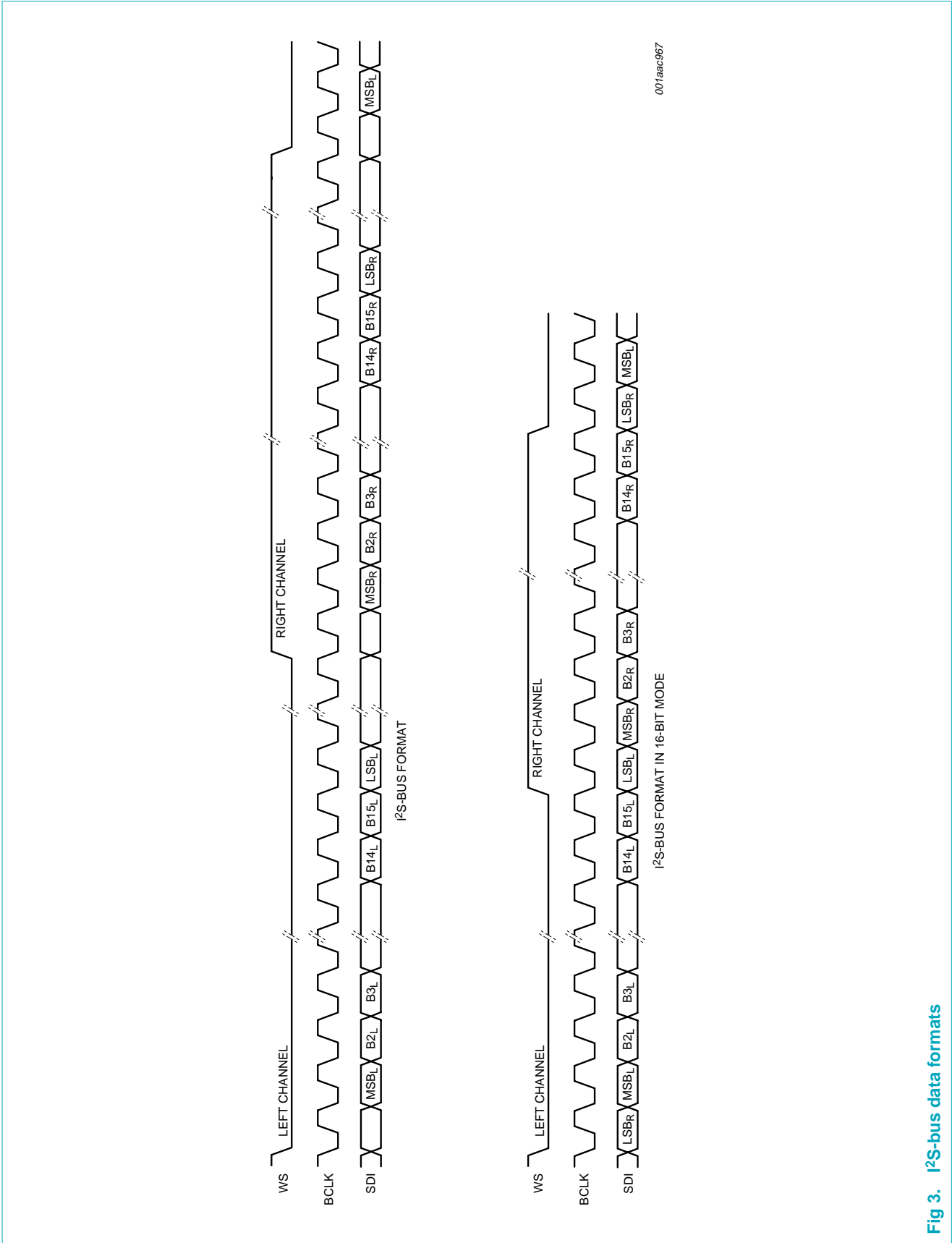

Fig 3. I²S-bus data formats

9. Limiting values

Table 4. Limiting values

In accordance with the Absolute Maximum Rating System (IEC 60134).

Symbol	Parameter	Conditions	Min	Max	Unit
V _{DDA}	analog supply voltage (for DAC)	[1]	-	15.2	V
V _{DDD}	digital supply voltage	[1]	-	5.5	V
T _{xtal}	crystal temperature		-	125	°C
T _{stg}	storage temperature		-65	+125	°C

[1] All supply connections must be made to the same power supply.

10. Thermal characteristics

Table 5. Thermal characteristics

Symbol	Parameter	Conditions	Typ	Unit
R _{th(j-a)}	thermal resistance from junction to ambient	in free air	115	K/W

11. Static characteristics

Table 6. Static characteristics

$V_{DDA} = 12.0\text{ V}$; $V_{DDD} = 3.3\text{ V}$; $T_{amb} = 25\text{ °C}$; all voltages referenced to ground (pins V_{SSA} and V_{SSD}); unless otherwise specified.

Symbol	Parameter	Conditions	Min	Typ	Max	Unit	
Supplies							
V_{DDA}	analog supply voltage (for DAC)		10.8	12.0	13.2	V	
V_{DDD}	digital supply voltage		3.1	3.3	3.5	V	
I_{DDA}	analog supply current (for DAC)	$V_{DDA} = 12.0\text{ V}$					
		operating	[1]	-	6.6	-	mA
		power-down	-	-	0.8	-	mA
I_{DDD}	digital supply current	$V_{DDD} = 3.3\text{ V}$					
		operating	[1]	-	7.0	-	mA
		power-down	-	-	6.8	-	mA
P_{tot}	total power dissipation	operating	[1]	-	102	mW	
T_{amb}	ambient temperature		5	-	65	°C	
Digital inputs: pins BCLK, WS, SDI, PD_N and MCLK							
V_{IL}	LOW-level input voltage		0	-	$0.3V_{DDD}$	V	
V_{IH}	HIGH-level input voltage		$0.7V_{DDD}$	-	V_{DDD}	V	
$ I_{Ll} $	input leakage current (absolute value)		-	-	1	μA	
C_i	input capacitance		-	-	2.5	pF	
Digital-to-analog converter							
$V_{O(DC)}$	channel DC output voltage	with respect to pin V_{SSA}	-	4.9	-	V	

[1] A 1 kHz at 0 dB sine wave input is applied.

12. Dynamic characteristics

Table 7. Dynamic characteristics

$V_{DDA} = 12.0\text{ V}$; $V_{DDD} = 3.3\text{ V}$; $T_{amb} = 25\text{ °C}$; $f_s = 48\text{ kHz}$; $f_i = 1\text{ kHz}$; all voltages referenced to ground (pins V_{SSA} and V_{SSD}); unless otherwise specified.

Symbol	Parameter	Conditions	Min	Typ	Max	Unit
Digital-to-analog converter						
$V_{o(rms)}$	output voltage (RMS value)		1.575	1.880	1.925	V
ΔV_o	unbalance between channels	at -20 dB on both channels	-	-	0.5	dB
(THD + N)/S	total harmonic distortion-plus-noise to signal ratio	at 0 dB	[1][2] -62	-66	-	dB
		at -60 dB	[1][3] -	-32.5	-	dB
DNR	dynamic range	at -60 dB	[3][4] 89	92.5	-	dB
S/N	signal-to-noise ratio		[2][5] 89	94	-	dB
G_{pb}	pass-band gain	at -20 dB; over the band 20 Hz to 20 kHz	-1.0	-	+0.5	dB
B	bandwidth	at -3 dB cut-off frequency	-	22	-	kHz
ϕ_{mis}	phase mismatch	at -20 dB; over the band 20 Hz to 20 kHz	-	0.2	1.5	deg
α_{cs}	channel separation	at 0 dB; from 1 kHz to 20 kHz	85	98	-	dB

[1] (THD + N)/S is the power ratio between the sum of noise and distortion, and the output signal.

[2] Measurement is performed with a 22 kHz low-pass filter and is unweighted.

[3] Measurement is performed with a ITU-R-2K filter and is unweighted.

[4] DNR is the result of (THD + N)/S corrected with the full-scale ratio (60 dB in this case).

[5] S/N is the power ratio between the output signal and the noise measured with no signal applied.

Table 8. Timing characteristics

$V_{DDA} = 12.0\text{ V}$; $V_{DDD} = 3.3\text{ V}$; $T_{amb} = 5\text{ °C to }65\text{ °C}$; $f_s = 48\text{ kHz}$; all voltages referenced to ground (pins V_{SSA} and V_{SSD}); unless otherwise specified.

Symbol	Parameter	Conditions	Min	Typ	Max	Unit
$t_{d(po-so)}$	delay time from power on to stable output	MCLK active	[1] -	-	500	ms
Master clock (see Figure 4)						
Master clock input: pin MCLK						
$T_{cy(MCLK)}$	master clock cycle time		-	81.4	-	ns
t_{WL}	pulse width LOW		28	-	53	ns
t_{WH}	pulse width HIGH		28	-	53	ns
Digital interface (see Figure 5)						
Bit clock input: pin BCLK						
$T_{cy(BCLK)}$	bit clock cycle time		20.83	-	-	μs
t_{WL}	pulse width LOW		7.29	-	-	μs

Table 8. Timing characteristics ...continued

$V_{DDA} = 12.0\text{ V}$; $V_{DDD} = 3.3\text{ V}$; $T_{amb} = 5\text{ }^{\circ}\text{C}$ to $65\text{ }^{\circ}\text{C}$; $f_s = 48\text{ kHz}$; all voltages referenced to ground (pins V_{SSA} and V_{SSD}); unless otherwise specified.

Symbol	Parameter	Conditions	Min	Typ	Max	Unit
t_{WH}	pulse width HIGH		7.29	-	-	μs
t_r	rise time		-	-	3.12	μs
t_f	fall time		-	-	3.12	μs
Data input: pin SDI						
$t_{su(SDI)}$	data input set-up time		4.16	-	-	μs
$t_{h(SDI)}$	data input hold time		0	-	-	μs
Word select input: pin WS						
$t_{su(WS)}$	word select set-up time		4.16	-	-	μs
$t_{h(WS)}$	word select hold time		0	-	-	μs

[1] The device is ready to receive audio data only after 128 MCLK periods from the end of the reset; see [Section 8.4](#).

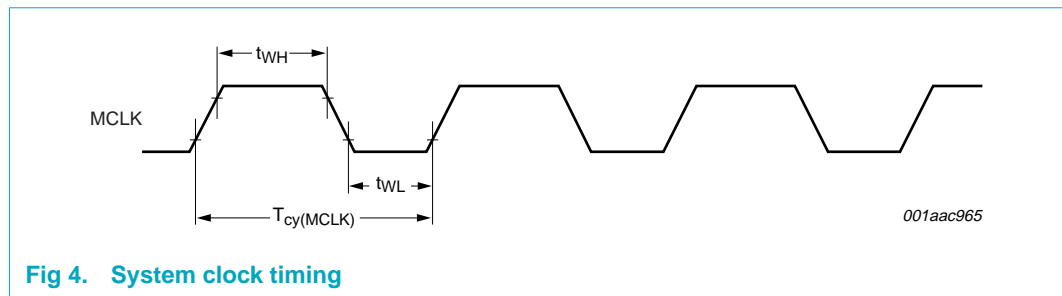

Fig 4. System clock timing

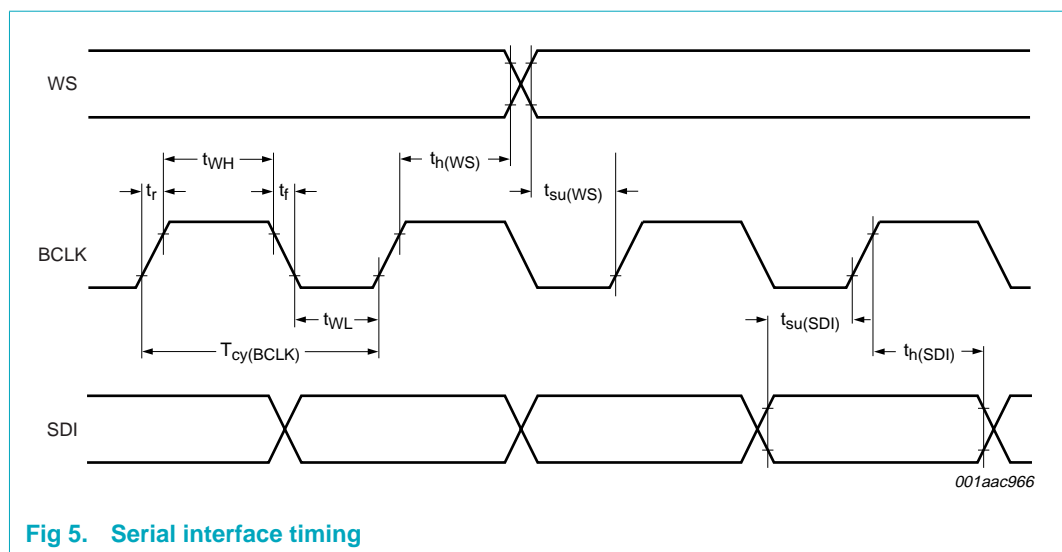
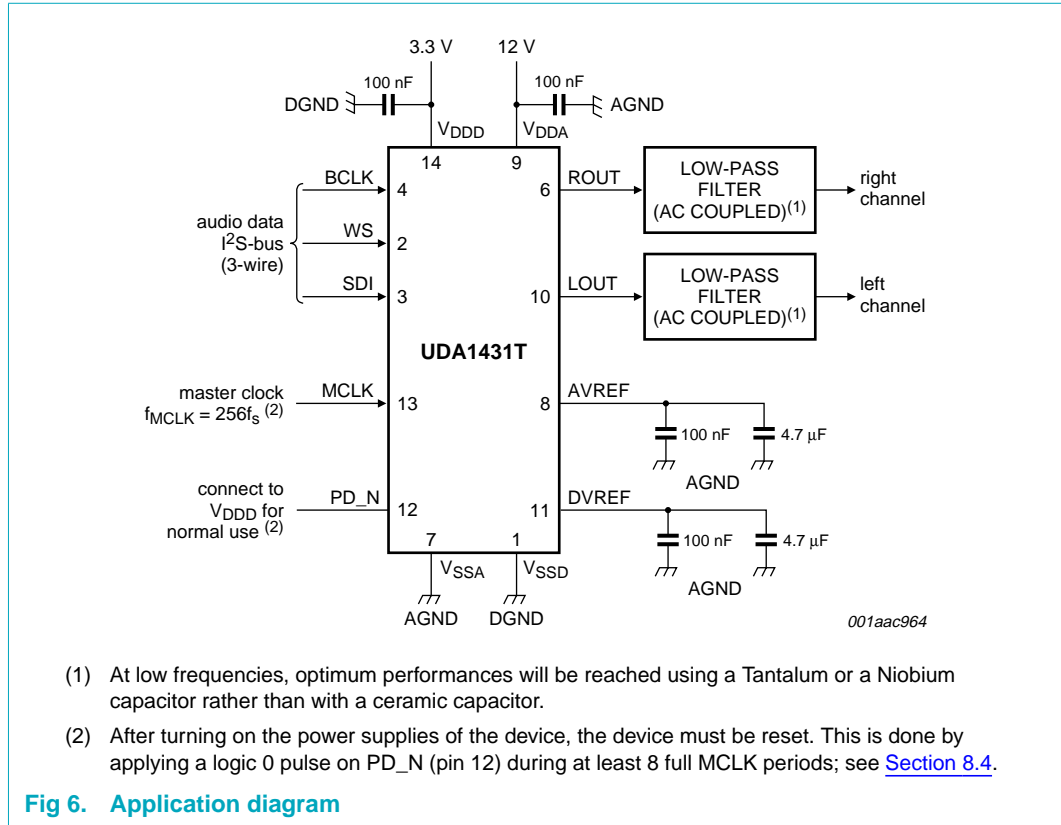

Fig 5. Serial interface timing

13. Application information



14. Test information

14.1 Quality information

The *General Quality Specification for Integrated Circuits, SNW-FQ-611* is applicable.

15. Package outline

SO14: plastic small outline package; 14 leads; body width 3.9 mm

SOT108-1

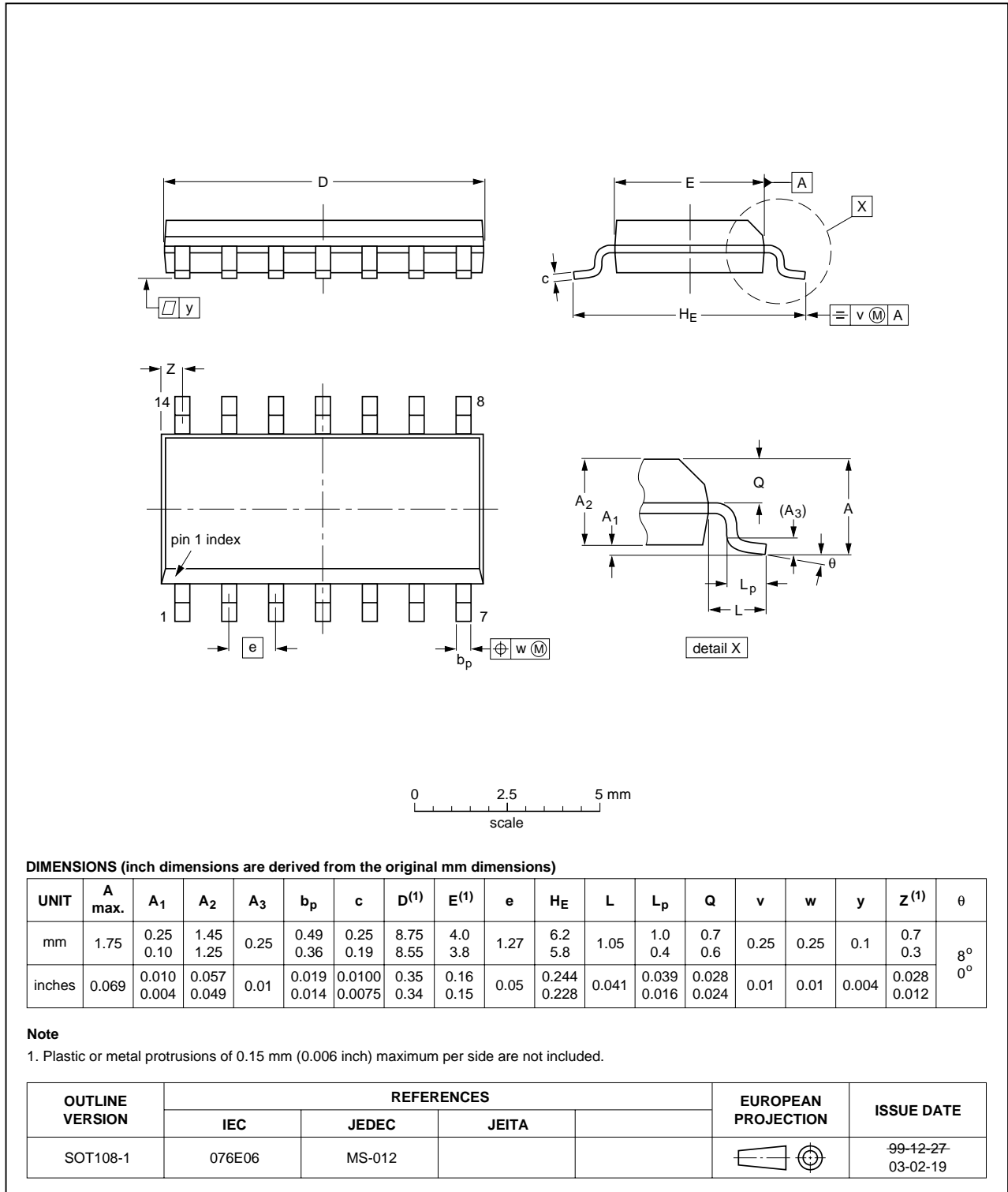

Fig 7. Package outline SOT108-1 (SO14)

16. Handling information

Inputs and outputs are protected against electrostatic discharge in normal handling. However, to be completely safe you must take normal precautions appropriate to handling integrated circuits.

17. Soldering

17.1 Introduction to soldering surface mount packages

There is no soldering method that is ideal for all surface mount IC packages. Wave soldering can still be used for certain surface mount ICs, but it is not suitable for fine pitch SMDs. In these situations reflow soldering is recommended.

17.2 Reflow soldering

Reflow soldering requires solder paste (a suspension of fine solder particles, flux and binding agent) to be applied to the printed-circuit board by screen printing, stencilling or pressure-syringe dispensing before package placement. Driven by legislation and environmental forces the worldwide use of lead-free solder pastes is increasing.

Several methods exist for reflowing; for example, convection or convection/infrared heating in a conveyor type oven. Throughput times (preheating, soldering and cooling) vary between 100 seconds and 200 seconds depending on heating method.

Typical reflow temperatures range from 215 °C to 260 °C depending on solder paste material. The peak top-surface temperature of the packages should be kept below:

Table 9. SnPb eutectic process - package peak reflow temperatures (from J-STD-020C July 2004)

Package thickness	Volume mm ³ < 350	Volume mm ³ ≥ 350
< 2.5 mm	240 °C + 0/-5 °C	225 °C + 0/-5 °C
≥ 2.5 mm	225 °C + 0/-5 °C	225 °C + 0/-5 °C

Table 10. Pb-free process - package peak reflow temperatures (from J-STD-020C July 2004)

Package thickness	Volume mm ³ < 350	Volume mm ³ 350 to 2000	Volume mm ³ > 2000
< 1.6 mm	260 °C + 0 °C	260 °C + 0 °C	260 °C + 0 °C
1.6 mm to 2.5 mm	260 °C + 0 °C	250 °C + 0 °C	245 °C + 0 °C
≥ 2.5 mm	250 °C + 0 °C	245 °C + 0 °C	245 °C + 0 °C

Moisture sensitivity precautions, as indicated on packing, must be respected at all times.

17.3 Wave soldering

Conventional single wave soldering is not recommended for surface mount devices (SMDs) or printed-circuit boards with a high component density, as solder bridging and non-wetting can present major problems.

To overcome these problems the double-wave soldering method was specifically developed.

If wave soldering is used the following conditions must be observed for optimal results:

- Use a double-wave soldering method comprising a turbulent wave with high upward pressure followed by a smooth laminar wave.
- For packages with leads on two sides and a pitch (e):
 - larger than or equal to 1.27 mm, the footprint longitudinal axis is **preferred** to be parallel to the transport direction of the printed-circuit board;
 - smaller than 1.27 mm, the footprint longitudinal axis **must** be parallel to the transport direction of the printed-circuit board.

The footprint must incorporate solder thieves at the downstream end.

- For packages with leads on four sides, the footprint must be placed at a 45° angle to the transport direction of the printed-circuit board. The footprint must incorporate solder thieves downstream and at the side corners.

During placement and before soldering, the package must be fixed with a droplet of adhesive. The adhesive can be applied by screen printing, pin transfer or syringe dispensing. The package can be soldered after the adhesive is cured.

Typical dwell time of the leads in the wave ranges from 3 seconds to 4 seconds at 250 °C or 265 °C, depending on solder material applied, SnPb or Pb-free respectively.

A mildly-activated flux will eliminate the need for removal of corrosive residues in most applications.

17.4 Manual soldering

Fix the component by first soldering two diagonally-opposite end leads. Use a low voltage (24 V or less) soldering iron applied to the flat part of the lead. Contact time must be limited to 10 seconds at up to 300 °C.

When using a dedicated tool, all other leads can be soldered in one operation within 2 seconds to 5 seconds between 270 °C and 320 °C.

17.5 Package related soldering information

Table 11. Suitability of surface mount IC packages for wave and reflow soldering methods

Package ^[1]	Soldering method	
	Wave	Reflow ^[2]
BGA, HTSSON..T ^[3] , LBGA, LFBGA, SQFP, SSOP..T ^[3] , TFBGA, VFBGA, XSON	not suitable	suitable
DHVQFN, HBCC, HBGA, HLQFP, HSO, HSOP, HSQFP, HSSON, HTQFP, HTSSOP, HVQFN, HVSON, SMS	not suitable ^[4]	suitable
PLCC ^[5] , SO, SOJ	suitable	suitable
LQFP, QFP, TQFP	not recommended ^{[5][6]}	suitable
SSOP, TSSOP, VSO, VSSOP	not recommended ^[7]	suitable
CWQCCN..L ^[8] , PMFP ^[9] , WQCCN..L ^[8]	not suitable	not suitable

- [1] For more detailed information on the BGA packages refer to the *(LF)BGA Application Note* (AN01026); order a copy from your Philips Semiconductors sales office.
- [2] All surface mount (SMD) packages are moisture sensitive. Depending upon the moisture content, the maximum temperature (with respect to time) and body size of the package, there is a risk that internal or external package cracks may occur due to vaporization of the moisture in them (the so called popcorn effect). For details, refer to the Drypack information in the *Data Handbook IC26; Integrated Circuit Packages; Section: Packing Methods*.
- [3] These transparent plastic packages are extremely sensitive to reflow soldering conditions and must on no account be processed through more than one soldering cycle or subjected to infrared reflow soldering with peak temperature exceeding $217\text{ °C} \pm 10\text{ °C}$ measured in the atmosphere of the reflow oven. The package body peak temperature must be kept as low as possible.
- [4] These packages are not suitable for wave soldering. On versions with the heatsink on the bottom side, the solder cannot penetrate between the printed-circuit board and the heatsink. On versions with the heatsink on the top side, the solder might be deposited on the heatsink surface.
- [5] If wave soldering is considered, then the package must be placed at a 45° angle to the solder wave direction. The package footprint must incorporate solder thieves downstream and at the side corners.
- [6] Wave soldering is suitable for LQFP, QFP and TQFP packages with a pitch (e) larger than 0.8 mm; it is definitely not suitable for packages with a pitch (e) equal to or smaller than 0.65 mm.
- [7] Wave soldering is suitable for SSOP, TSSOP, VSO and VSSOP packages with a pitch (e) equal to or larger than 0.65 mm; it is definitely not suitable for packages with a pitch (e) equal to or smaller than 0.5 mm.
- [8] Image sensor packages in principle should not be soldered. They are mounted in sockets or delivered pre-mounted on flex foil. However, the image sensor package can be mounted by the client on a flex foil by using a hot bar soldering process. The appropriate soldering profile can be provided on request.
- [9] Hot bar soldering or manual soldering is suitable for PMFP packages.

18. Revision history

Table 12. Revision history

Document ID	Release date	Data sheet status	Change notice	Supersedes
UDA1431T_4	20060530	Product data sheet	-	UDA1431T_3
Modifications:	<ul style="list-style-type: none">• Added: Section 8.4 “Reset”• Changed: table note 2 of Table 8 and figure note 2 of Figure 6			
UDA1431T_3	20060329	Product data sheet	-	UDA1431T_2
UDA1431T_2	20060220	Product data sheet	-	UDA1431T_1 (9397 750 14957)
UDA1431T_1 (9397 750 14957)	20060206	Product data sheet	-	-

19. Legal information

19.1 Data sheet status

Document status ^{[1][2]}	Product status ^[3]	Definition
Objective [short] data sheet	Development	This document contains data from the objective specification for product development.
Preliminary [short] data sheet	Qualification	This document contains data from the preliminary specification.
Product [short] data sheet	Production	This document contains the product specification.

[1] Please consult the most recently issued document before initiating or completing a design.

[2] The term 'short data sheet' is explained in section "Definitions".

[3] The product status of device(s) described in this document may have changed since this document was published and may differ in case of multiple devices. The latest product status information is available on the Internet at URL <http://www.semiconductors.philips.com>.

19.2 Definitions

Draft — The document is a draft version only. The content is still under internal review and subject to formal approval, which may result in modifications or additions. Philips Semiconductors does not give any representations or warranties as to the accuracy or completeness of information included herein and shall have no liability for the consequences of use of such information.

Short data sheet — A short data sheet is an extract from a full data sheet with the same product type number(s) and title. A short data sheet is intended for quick reference only and should not be relied upon to contain detailed and full information. For detailed and full information see the relevant full data sheet, which is available on request via the local Philips Semiconductors sales office. In case of any inconsistency or conflict with the short data sheet, the full data sheet shall prevail.

19.3 Disclaimers

General — Information in this document is believed to be accurate and reliable. However, Philips Semiconductors does not give any representations or warranties, expressed or implied, as to the accuracy or completeness of such information and shall have no liability for the consequences of use of such information.

Right to make changes — Philips Semiconductors reserves the right to make changes to information published in this document, including without limitation specifications and product descriptions, at any time and without notice. This document supersedes and replaces all information supplied prior to the publication hereof.

Suitability for use — Philips Semiconductors products are not designed, authorized or warranted to be suitable for use in medical, military, aircraft, space or life support equipment, nor in applications where failure or

malfunction of a Philips Semiconductors product can reasonably be expected to result in personal injury, death or severe property or environmental damage. Philips Semiconductors accepts no liability for inclusion and/or use of Philips Semiconductors products in such equipment or applications and therefore such inclusion and/or use is for the customer's own risk.

Applications — Applications that are described herein for any of these products are for illustrative purposes only. Philips Semiconductors makes no representation or warranty that such applications will be suitable for the specified use without further testing or modification.

Limiting values — Stress above one or more limiting values (as defined in the Absolute Maximum Ratings System of IEC 60134) may cause permanent damage to the device. Limiting values are stress ratings only and operation of the device at these or any other conditions above those given in the Characteristics sections of this document is not implied. Exposure to limiting values for extended periods may affect device reliability.

Terms and conditions of sale — Philips Semiconductors products are sold subject to the general terms and conditions of commercial sale, as published at <http://www.semiconductors.philips.com/profile/terms>, including those pertaining to warranty, intellectual property rights infringement and limitation of liability, unless explicitly otherwise agreed to in writing by Philips Semiconductors. In case of any inconsistency or conflict between information in this document and such terms and conditions, the latter will prevail.

No offer to sell or license — Nothing in this document may be interpreted or construed as an offer to sell products that is open for acceptance or the grant, conveyance or implication of any license under any copyrights, patents or other industrial or intellectual property rights.

19.4 Trademarks

Notice: All referenced brands, product names, service names and trademarks are the property of their respective owners.

20. Contact information

For additional information, please visit: <http://www.semiconductors.philips.com>

For sales office addresses, send an email to: sales.addresses@www.semiconductors.philips.com

21. Contents

1	General description	1
2	Features	1
3	Applications	1
4	Quick reference data	2
5	Ordering information	2
6	Block diagram	3
7	Pinning information	3
7.1	Pinning	3
7.2	Pin description	3
8	Functional description	4
8.1	Master clock	4
8.2	Data formats	4
8.3	Noise shaper	4
8.4	Reset	4
9	Limiting values	6
10	Thermal characteristics	6
11	Static characteristics	7
12	Dynamic characteristics	8
13	Application information	10
14	Test information	10
14.1	Quality information	10
15	Package outline	11
16	Handling information	12
17	Soldering	12
17.1	Introduction to soldering surface mount packages	12
17.2	Reflow soldering	12
17.3	Wave soldering	12
17.4	Manual soldering	13
17.5	Package related soldering information	13
18	Revision history	15
19	Legal information	16
19.1	Data sheet status	16
19.2	Definitions	16
19.3	Disclaimers	16
19.4	Trademarks	16
20	Contact information	16
21	Contents	17

Please be aware that important notices concerning this document and the product(s) described herein, have been included in section 'Legal information'.



© Koninklijke Philips Electronics N.V. 2006. All rights reserved.

For more information, please visit: <http://www.semiconductors.philips.com>.
For sales office addresses, email to: sales.addresses@www.semiconductors.philips.com.

Date of release: 30 May 2006
Document identifier: UDA1431T_4