

DATA SHEET

CEL

**NEC's NPN SiGe RF IC
IN A 8-PIN LEAD-LESS MINIMOLD**

UPA901TU

FEATURES

- **OUTPUT POWER:**
P_{out} = 19 dBm @ P_{in} = -3 dBm, V_{CE} = 3.6 V, f = 5.8 GHz
- **LOW POWER:**
I_c = 90 mA @ P_{in} = -3 dBm, V_{CE} = 3.6 V, f = 5.8 GHz
- **SINGLE POWER SUPPLY OPERATION:**
V_{CE} = 3.6 V
- **BUILT-IN BIAS CIRCUIT**
- **8-PIN LEAD-LESS MINIMOLD:**
(2.0 × 2.2 × 0.5 mm)

DESCRIPTION

NEC's UPA901TU is a silicon germanium HBT IC designed for the power amplifier of 5.8 GHz cordless phone and other 5.8 GHz applications. This IC consists of two stage amplifiers and has excellent performance, high efficiency, high gain, low power consumption.

NEC's UPA901TU is packaged in surface mount 8-pin lead-less minimold plastic package.

This device is fabricated with our SiGe HBT process UHS2-HV technology.

APPLICATIONS

- 5.8 GHz Cordless Phones
- 5.8 GHz Band DSRC (Dedicated Short Range Communication) System
- 5 GHz Band Video Transmitter

ORDERING INFORMATION

PART NUMBER	ORDER NUMBER	QUANTITY	PACKAGE	MARKING	SUPPLYING FORM
UPA901TU	UPA901TU-A	50 pcs (Non reel)	8-pin lead-less minimold(Pb-Free)	A901	• 8 mm wide embossed taping
UPA901TU-T3	UPA901TU-T3-A	5 kpcs/reel			• Pin 1, Pin 8 face the perforation side of the tape

Remark To order evaluation samples, contact your nearby sales office.
The unit sample quantity is 50 pcs.



UPA901TU

PIN CONNECTIONS AND INTERNAL BLOCK DIAGRAM

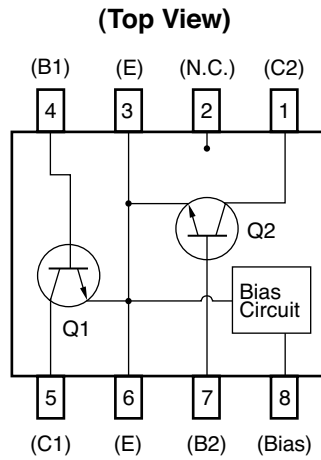

ABSOLUTE MAXIMUM RATINGS (TA = +25°C)

PARAMETER	SYMBOL	RATINGS	UNIT
Collector to Base Voltage	V _{CBO}	15	V
Collector to Emitter Voltage	V _{CEO}	4.5	V
Emitter to Base Voltage	V _{EBO}	2	V
Collector Current of Q1	I _{C1}	75	mA
Collector Current of Q2	I _{C2}	250	mA
Bias Current	I _{BIAS}	25	mA
Total Power Dissipation	P _{tot} ^{Note}	410	mW
Junction Temperature	T _j	150	°C
Storage Temperature	T _{stg}	-65 to +150	°C
Operating Ambient Temperature	T _A	-40 to +85	°C

Note Mounted on 20 × 20 × 0.8 mm (t) glass epoxy PCB (FR-4)

THERMAL RESISTANCE (TA = +25°C)

PARAMETER	SYMBOL	TEST CONDITIONS	RATINGS	UNIT
Channel to Ambient Resistance	R _{th(j-a1)} ^{Note}		150	°C/W
	R _{th(j-a2)}	Free Air	TBD	°C/W

Note Mounted on 20 × 20 × 0.8 mm (t) glass epoxy PCB (FR-4)

RECOMMENDED OPERATING RANGE (All Parameters)

PARAMETER	SYMBOL	MIN.	TYP.	MAX.	UNIT
Collector to Emitter Voltage	V _{CE}	-	3.6	4.5	V
Total Current	I _{total}	-	90	300	mA
Input Power	P _{in}	-	-3	+5	dBm

ELECTRICAL CHARACTERISTICS (TA = +25°C)

-DC CHARACTERISTICS-

(1) Q1

PARAMETER	SYMBOL	TEST CONDITIONS	MIN.	TYP.	MAX.	UNIT
Collector Cut-off Current	ICBO	V _{CB} = 5 V, I _E = 0 mA	–	–	60	nA
Emitter Cut-off Current	IEBO	V _{EB} = 1 V, I _C = 0 mA	–	–	120	nA
DC Current Gain	h _{FE} <i>Note</i>	V _{CE} = 3 V, I _C = 6 mA	80	120	160	–
Current Ratio (I _{C (set) 1} /I _{BIAS})	CR1	V _{CE} = 3.6 V, V _{BE} = V _{BIAS} = 0.865 V	2	4.5	9	–

(2) Q2

PARAMETER	SYMBOL	TEST CONDITIONS	MIN.	TYP.	MAX.	UNIT
Collector Cut-off Current	ICBO	V _{CB} = 5 V, I _E = 0 mA	–	–	200	nA
Emitter Cut-off Current	IEBO	V _{EB} = 1 V, I _C = 0 mA	–	–	400	nA
DC Current Gain	h _{FE} <i>Note</i>	V _{CE} = 3 V, I _C = 20 mA	80	120	160	–
Current Ratio (I _{C (set) 2} /I _{BIAS})	CR2	V _{CE} = 3.6 V, V _{BE} = V _{BIAS} = 0.865 V	8	10	13	–

(3) Bias Circuit

PARAMETER	SYMBOL	TEST CONDITIONS	MIN.	TYP.	MAX.	UNIT
Bias Circuit Current	I _{BIAS}	V _{BIAS} = 0.865 V	–	4	–	mA

Note Pulse measurement: PW ≤ 350 μs, Duty Cycle ≤ 2%

I_{BIAS}, I_{C (set) 1}, I_{C (set) 2} MEASUREMENT CIRCUIT

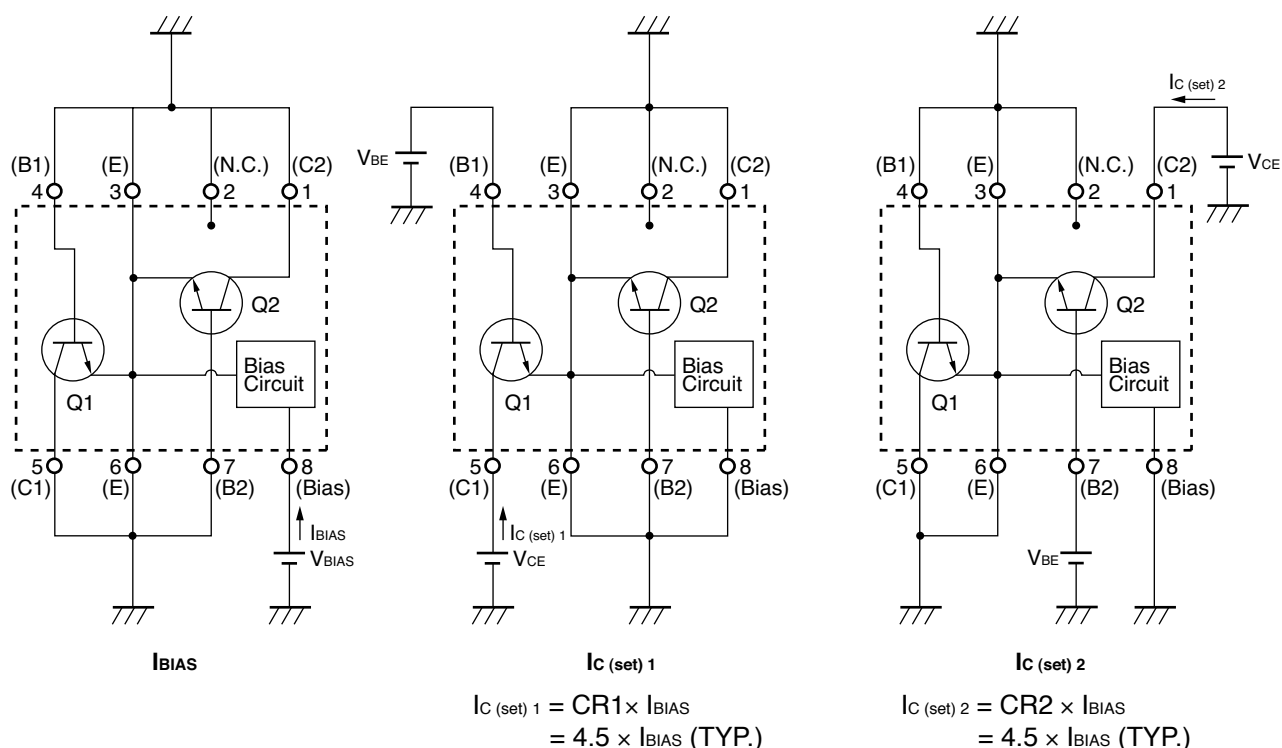

UPA901TU

ELECTRICAL CHARACTERISTICS (T_A = +25°C)

-RF CHARACTERISTICS-

(1) Q1

PARAMETER	SYMBOL	TEST CONDITIONS	MIN.	TYP.	MAX.	UNIT
Insertion Power Gain (Q1)	$ S_{21e} ^2$	V _{CE} = 3.6 V, I _C = 12 mA, f = 5.8 GHz	8.5	10.0	11.5	dB
Maximum Available Power Gain (Q1)	MAG1	V _{CE} = 3.6 V, I _C = 12 mA, f = 5.8 GHz	13.5	15.0	–	dB
Output Power (Q1)	P _{out1}	V _{CE} = 3.6 V, I _{C(set)} = 12 mA, f = 5.8 GHz, P _{in} = –3 dBm	10.2	11.2	–	dBm
Collector Current (Q1)	I _{cc1}	V _{CE} = 3.6 V, I _{C(set)} = 12 mA, f = 5.8 GHz, P _{in} = –3 dBm	–	20	–	mA

(2) Q2

PARAMETER	SYMBOL	TEST CONDITIONS	MIN.	TYP.	MAX.	UNIT
Insertion Power Gain (Q2)	$ S_{21e} ^2$	V _{CE} = 3.6 V, I _C = 40 mA, f = 5.8 GHz	2	3.5	5	dB
Maximum Available Power Gain (Q2)	MAG2	V _{CE} = 3.6 V, I _C = 40 mA, f = 5.8 GHz	8.5	10.0	10.5	dB
Output Power (Q2)	P _{out2}	V _{CE} = 3.6 V, I _{C(set)} = 40 mA, f = 5.8 GHz, P _{in} = 11 dBm	17.5	19.0	–	dBm
Collector Current (Q2)	I _{cc2}	V _{CE} = 3.6 V, I _{C(set)} = 40 mA, f = 5.8 GHz, P _{in} = 11 dBm	–	70	–	mA

(3) Q1 + Q2, 2 stage Amplifiers

PARAMETER	SYMBOL	TEST CONDITIONS	MIN.	TYP.	MAX.	UNIT
Output Power (Q1 + Q2)	P _{out}	V _{CE} = 3.6 V, R _{BIAS} = 680 Ω, f = 5.8 GHz, P _{in} = –3 dBm Note	17.5	19.0	–	dBm
Total Current (Q1 + Q2)	I _{total}	V _{CE} = 3.6 V, R _{BIAS} = 680 Ω, f = 5.8 GHz, P _{in} = –3 dBm Note	–	90	–	mA

Note by MEASUREMENT CIRCUIT 1

MEASUREMENT CIRCUIT 1

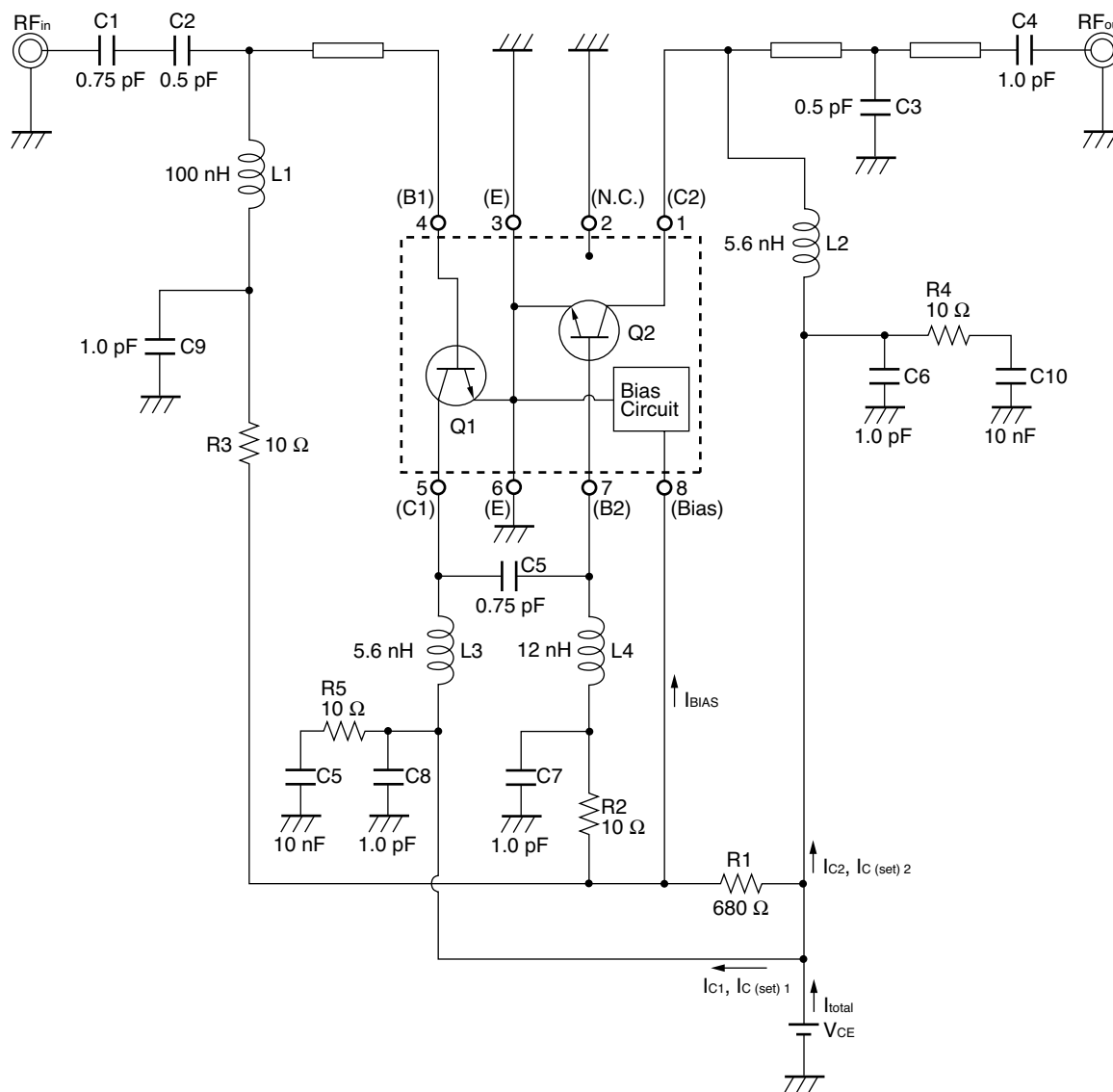

$$I_{C(\text{set})1} = CR1 \times I_{\text{BIAS}} = 4.5 \times I_{\text{BIAS}} \text{ (TYP.)}$$

$$I_{C(\text{set})2} = CR2 \times I_{\text{BIAS}} = 4.5 \times I_{\text{BIAS}} \text{ (TYP.)}$$

The application circuits and their parameters are for reference only and are not intended for actual design-ins.

ILLUSTRATION OF THE TEST CIRCUIT ASSEMBLED ON EVALUATION BOARD

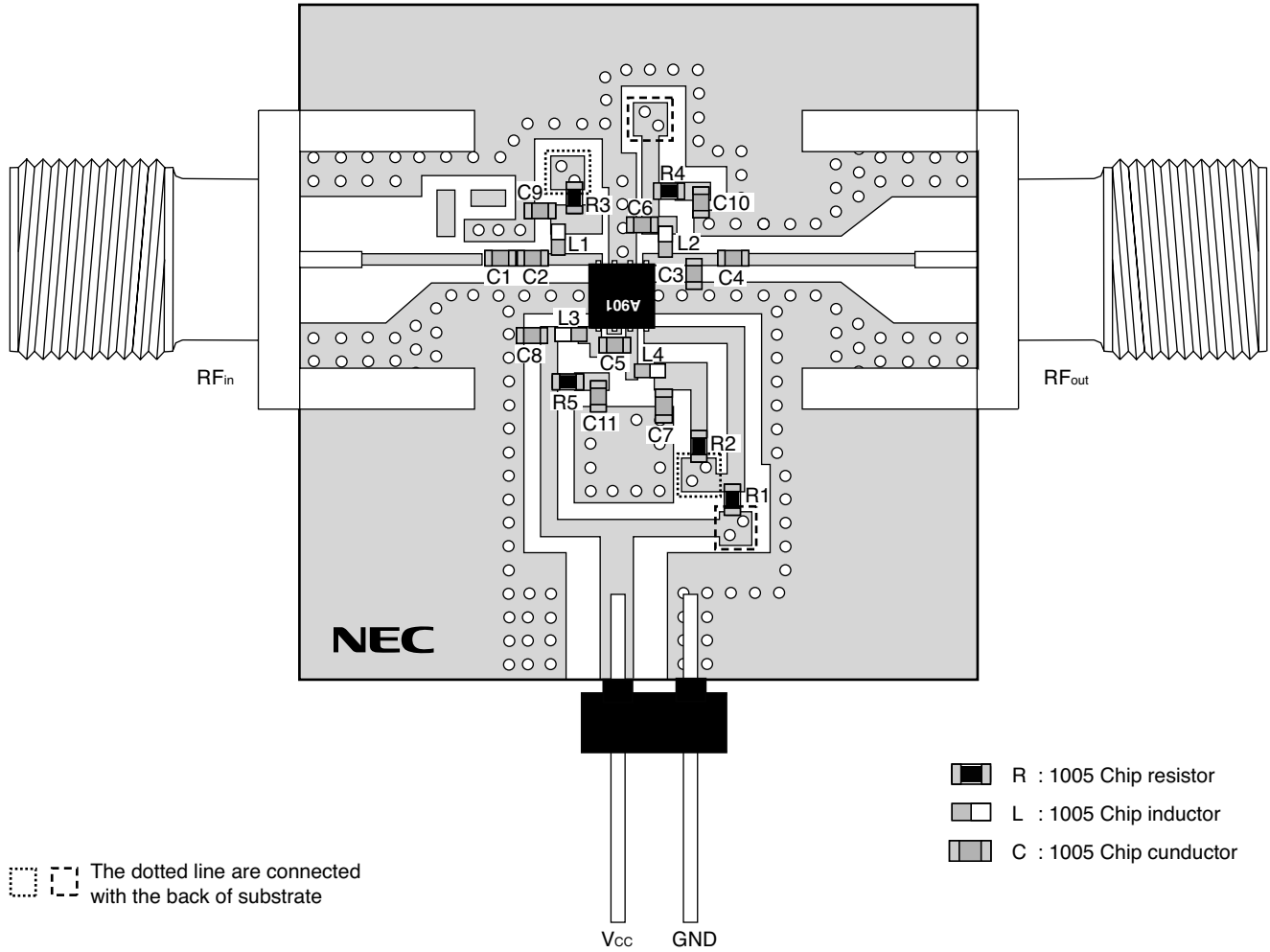

Remarks

1. Substrate : 20 × 20 × 0.8 (t) mm FR-4 (4 Layer, each thickness 0.2 mm), copper thickness 18 μm, gold flash plating
2. Back side : GND pattern
3. o : Through hole

USING THE NEC EVALUATION BOARD

SYMBOL	VALUES	SYMBOL	VALUES
R1	680 Ω	C2	0.5 pF
R2	10 Ω	C3	0.5 pF
R3	10 Ω	C4	1.0 pF
R4	10 Ω	C5	0.75 pF
R5	10 Ω	C6	1.0 pF
L1	100 nH	C7	1.0 pF
L2	5.6 nH	C8	1.0 pF
L3	5.6 nH	C9	1.0 pF
L4	12 nH	C10	10 nF
C1	0.75 pF	C11	10 nF

TYPICAL CHARACTERISTICS ($T_A = +25^\circ\text{C}$, $V_{CE} = 3.6\text{ V}$, $R_{BIAS} = 680\ \Omega$, $f = 5.8\text{ GHz}$, unless otherwise specified)

OUTPUT POWER, TOTAL CURRENT, TOTAL POWER EFFICIENCY vs. INPUT POWER

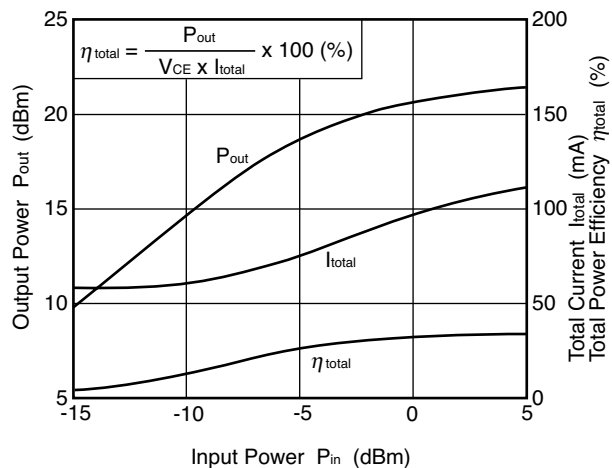

OUTPUT POWER, TOTAL CURRENT, vs. INPUT POWER

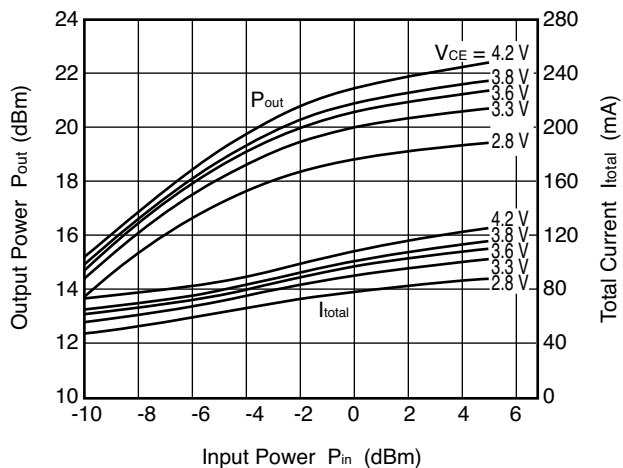

OUTPUT POWER, TOTAL CURRENT, vs. INPUT POWER

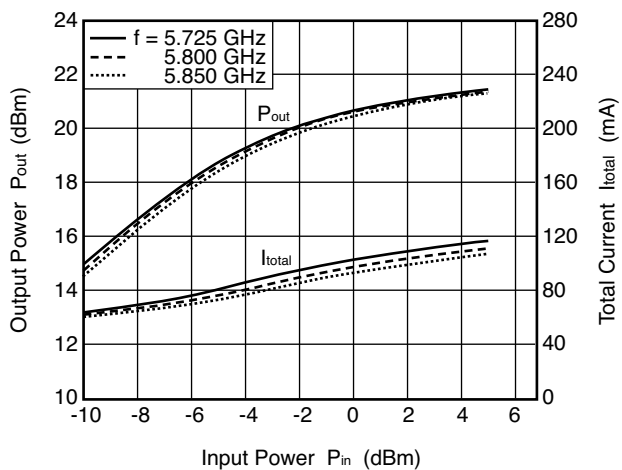

BIAS CIRCUIT CURRENT vs. COLLECTOR TO EMITTER VOLTAGE

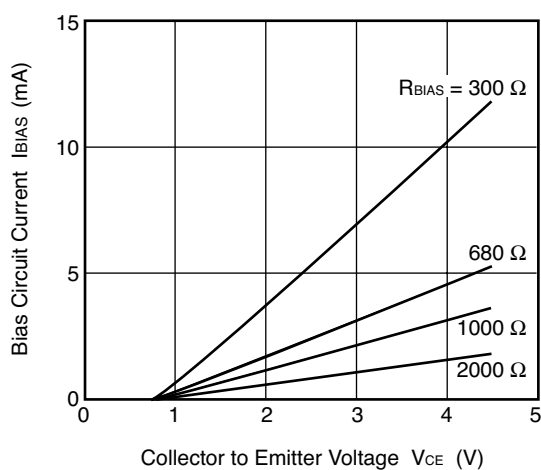

Remark The graphs indicate nominal characteristics.

UPA901TU

PACKAGE DIMENSIONS

8-PIN LEAD-LESS MINIMOLD (UNIT:mm)

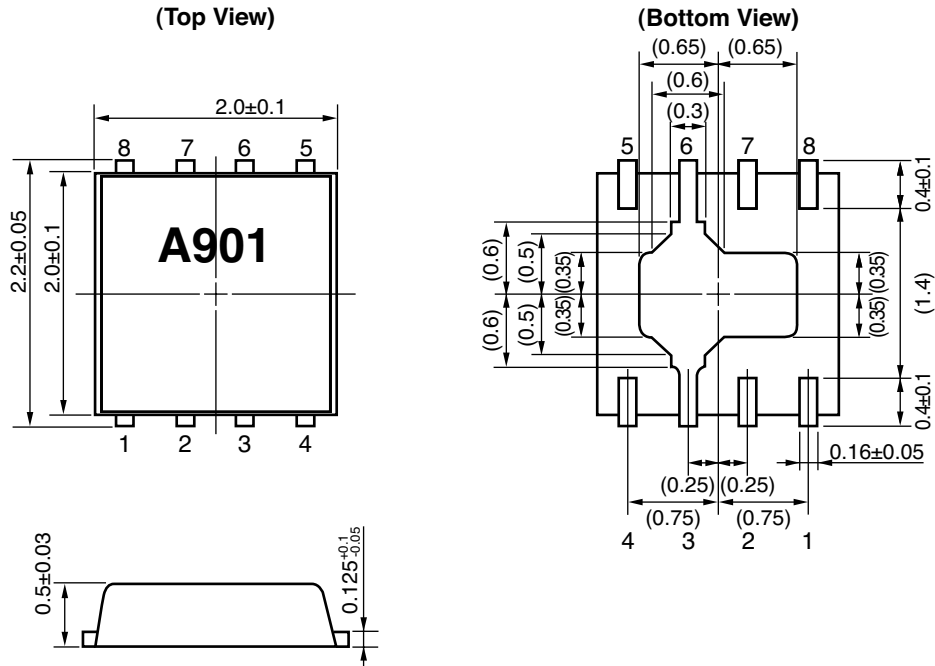

Remark () : Reference value

Life Support Applications

These NEC products are not intended for use in life support devices, appliances, or systems where the malfunction of these products can reasonably be expected to result in personal injury. The customers of CEL using or selling these products for use in such applications do so at their own risk and agree to fully indemnify CEL for all damages resulting from such improper use or sale.

Subject: Compliance with EU Directives

CEL certifies, to its knowledge, that semiconductor and laser products detailed below are compliant with the requirements of European Union (EU) Directive 2002/95/EC Restriction on Use of Hazardous Substances in electrical and electronic equipment (RoHS) and the requirements of EU Directive 2003/11/EC Restriction on Penta and Octa BDE.

CEL Pb-free products have the same base part number with a suffix added. The suffix –A indicates that the device is Pb-free. The –AZ suffix is used to designate devices containing Pb which are exempted from the requirement of RoHS directive (*). In all cases the devices have Pb-free terminals. All devices with these suffixes meet the requirements of the RoHS directive.

This status is based on CEL’s understanding of the EU Directives and knowledge of the materials that go into its products as of the date of disclosure of this information.

Restricted Substance per RoHS	Concentration Limit per RoHS (values are not yet fixed)	Concentration contained in CEL devices	
		-A	-AZ
Lead (Pb)	< 1000 PPM	Not Detected	(*)
Mercury	< 1000 PPM	Not Detected	
Cadmium	< 100 PPM	Not Detected	
Hexavalent Chromium	< 1000 PPM	Not Detected	
PBB	< 1000 PPM	Not Detected	
PBDE	< 1000 PPM	Not Detected	

If you should have any additional questions regarding our devices and compliance to environmental standards, please do not hesitate to contact your local representative.

Important Information and Disclaimer: Information provided by CEL on its website or in other communications concerning the substance content of its products represents knowledge and belief as of the date that it is provided. CEL bases its knowledge and belief on information provided by third parties and makes no representation or warranty as to the accuracy of such information. Efforts are underway to better integrate information from third parties. CEL has taken and continues to take reasonable steps to provide representative and accurate information but may not have conducted destructive testing or chemical analysis on incoming materials and chemicals. CEL and CEL suppliers consider certain information to be proprietary, and thus CAS numbers and other limited information may not be available for release.

In no event shall CEL’s liability arising out of such information exceed the total purchase price of the CEL part(s) at issue sold by CEL to customer on an annual basis.

See CEL Terms and Conditions for additional clarification of warranties and liability.