

NEC

DIVIDE- BY- 2 PRESCALER

UPB581B
UPB581C

FEATURES

- HIGH FREQUENCY OPERATION TO 2.8 GHz
- WIDE BAND OPERATION
- SINGLE SUPPLY VOLTAGE: $V_{CC} = 5\text{ V} \pm 10\%$
- COMPLEMENTARY OUTPUTS

DESCRIPTION

The UPB581 series of devices are divide-by-2 silicon bipolar digital prescalers. They feature high frequency response and operate from a single 5 volt supply. The series is available in two package styles: 8 lead ceramic flat package (UPB581B) and an 8 pin DIP (UPB581C). Applications include: frequency synthesis, division and scaling.

TEST CIRCUIT

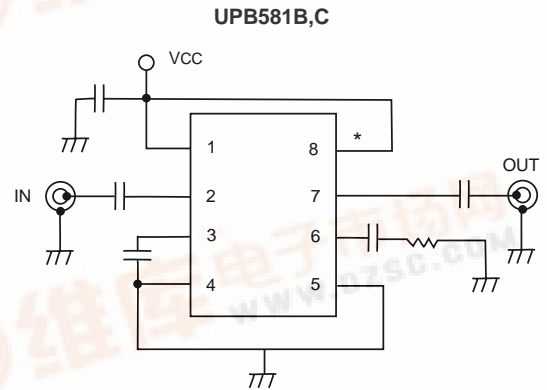

Note:
All capacitors are 2200 pF.
All resistors are 50 Ohms.
*Pin 8 is not connected for UPB581C.

ELECTRICAL CHARACTERISTICS ($V_{CC} = 5.0 \pm 0.5\text{ V}$, $Z_s = Z_L = 50\ \Omega$)

PART NUMBER PACKAGE OUTLINE			UPB581B BF08			UPB581C C08		
SYMBOLS	PARAMETERS AND CONDITIONS	UNITS	MIN	TYP	MAX	MIN	TYP	MAX
I _{CC}	Power Supply Current	mA	15	30	40	15	30	40
f _{IN}	Frequency Response at P _{IN} = -10 to -5 dBm ¹ P _{IN} = -5 to 0 dBm ¹ P _{IN} = 0 to +5 dBm ¹ P _{IN} = -5 to +10 dBm ² P _{IN} = -5 to +10 dBm ³ P _{IN} = -3 to +10 dBm ⁴	GHz	0.5		2.4			
		GHz	0.5		2.6			
		GHz	0.5		2.8			
		GHz				0.5		2.2
		GHz				0.5		2.4
		GHz				0.5		2.4
P _{IN}	Input Power at f _{IN} = 0.5 to 2.4 GHz ¹ f _{IN} = 0.5 to 2.6 GHz ¹ f _{IN} = 0.5 to 2.8 GHz ¹ f _{IN} = 0.5 to 2.2 GHz ² f _{IN} = 0.5 to 2.4 GHz ³ f _{IN} = 0.5 to 2.4 GHz ⁴	dBm	-10		+5			
		dBm	-5		+5			
		dBm	0		+5			
		dBm				-5		+10
		dBm				-5		+10
		dBm				-3		+10
P _{OUT}	Output Power ⁵	dBm	-12	-8		-12	-8	
R _{TH} (J-C)	Thermal Resistance, Junction to Case	°C/W			25			

Notes:

1. $T_A = -40$ to $+85^\circ\text{C}$.
2. $T_A = -35$ to $+85^\circ\text{C}$.
3. $T_A = -20$ to $+65^\circ\text{C}$, $V_{CC} = 5.0 \pm 0.25\text{ Volts}$.
4. $T_A = -20$ to $+70^\circ\text{C}$, $V_{CC} = 5.0 \pm 0.25\text{ Volts}$.
5. $T_A = +25^\circ\text{C}$, $f_{IN} = 2.0\text{ GHz}$, $P_{IN} = 0\text{ dBm}$.



UPB581B, UPB581C

ABSOLUTE MAXIMUM RATINGS¹ (T_A = 25°C)

SYMBOLS	PARAMETERS	UNITS	RATINGS
V _{CC}	Supply Voltage	V	-0.5 to 6.0
V _{IN}	Input Voltage	V	-0.5 to V _{CC} + 0.5
P _{IN}	Input Power	dBm	+10
P _D	Power Dissipation UPB581B ² UPB581C	mW	1500
		mW	600
T _{OP}	Operating Temperature UPB581B UPB581C	°C	-55 to +125
		°C	-55 to +85
T _{STG}	Storage Temperature UPB581B UPB581C	°C	-65 to +200
		°C	-55 to +125

Notes:

1. Operation in excess of any one of these parameters may result in permanent damage.
2. T_A = Absolute Maximum Operating Temperature.

TYPICAL PERFORMANCE CURVES

(T_A = 25°C unless otherwise noted.)

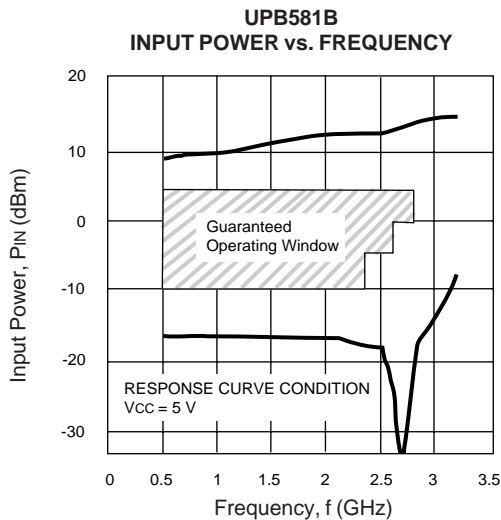

RECOMMENDED OPERATING CONDITIONS

SYMBOL	PARAMETER	UNITS	RATINGS
V _{CC}	Supply Voltage	V	4.5 to 5.5
T _{OP}	Operating Temperature UPB581B UPB581C	°C	-40 to +85
		°C	-20 to +75

Note: Because of the high internal gain and gain compression of the UPB581, this device is prone to self-oscillation in the absence of an RF input signal. If the device will be used in an application where DC power will be applied in the absence of an RF input signal, this self-oscillation can be suppressed by any of the following means:

- * Add a shunt resistor from the RF input line to ground. The blocking capacitor should be between the resistor and the UPB581, but physical separation should be minimized. Typically a resistor value between 50 and 100 ohms will suppress the self-oscillation.
- * Apply a DC offset voltage of +3.0 volts to the INPUT pin. The voltage source should be isolated from the INPUT pin by a series 1000 ohm resistor.
- * Apply a DC offset voltage of +1.5 volts to the BYPASS pin. The voltage source should be isolated from the BYPASS pin by a series 1000 ohm resistor.

All these approaches reduce the input sensitivity of the UPB581 (by as much as 3 dB for the example of a 50 ohm shunt resistor), but otherwise have no effect on the reliability or other electrical characteristics of this device.

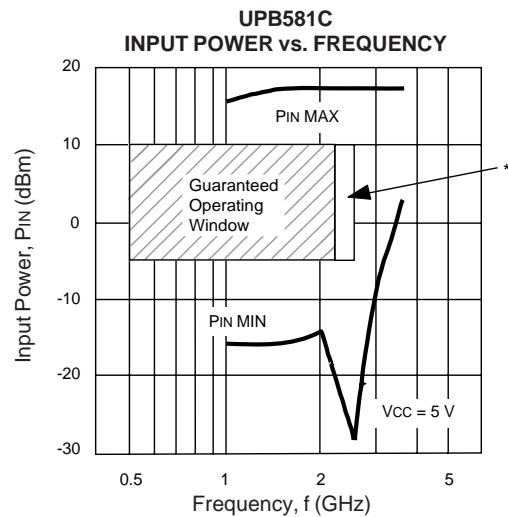

* See special conditions in Electrical Characteristics Table.

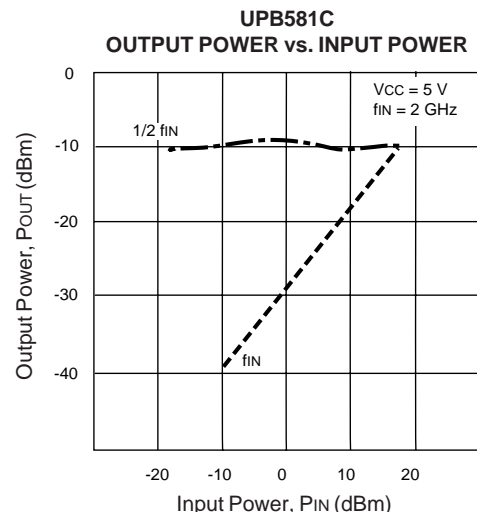
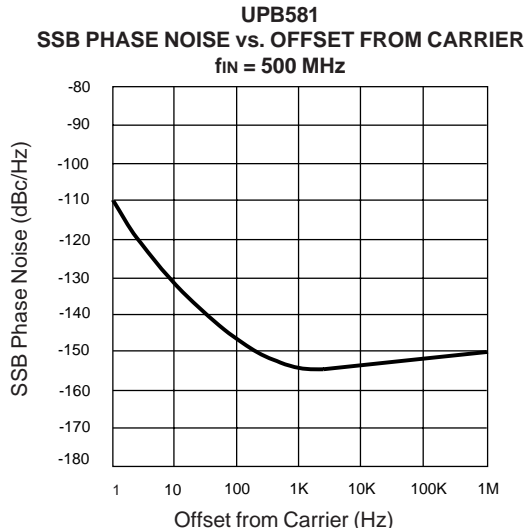

UPB581B, UPB581C

TYPICAL PERFORMANCE CURVES

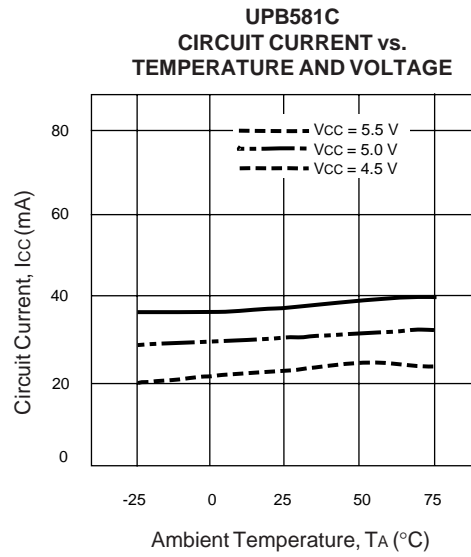
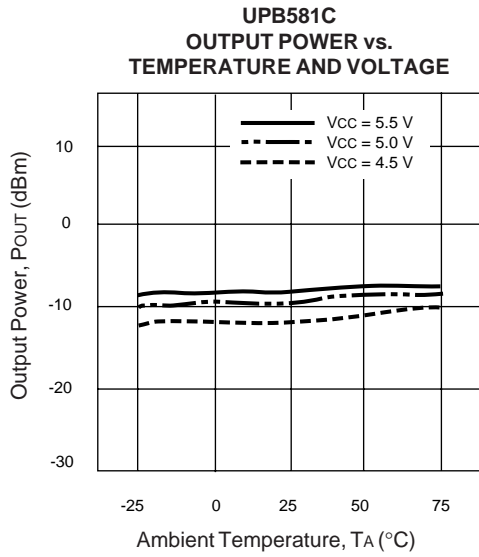
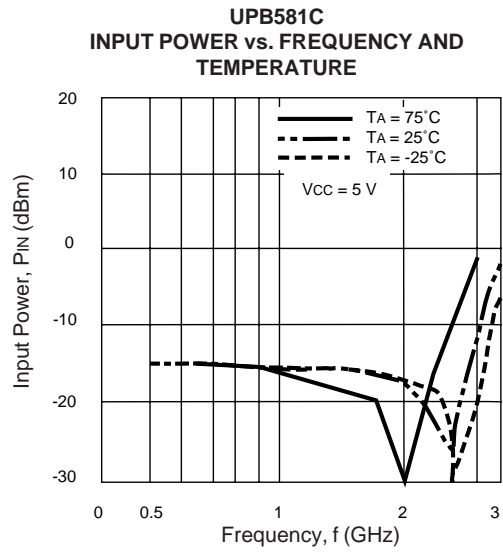
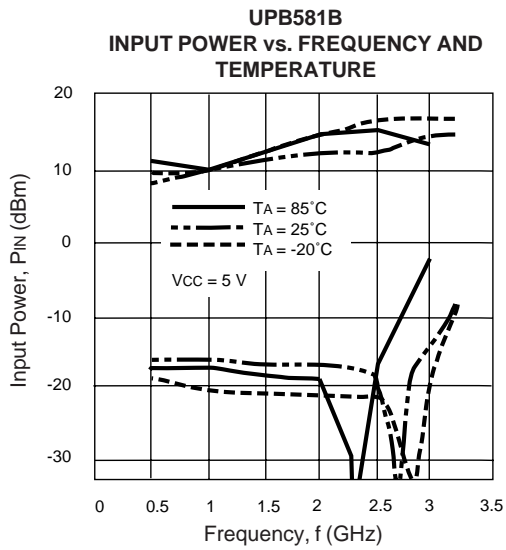

UPB581B, UPB581C

OUTLINE DIMENSIONS (Units in mm)

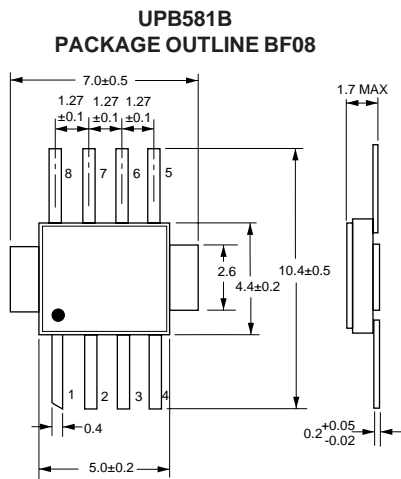

- PIN CONNECTIONS**
- | | |
|-----------|-------------|
| 1. Vcc | 5. GND |
| 2. Input | 6. Output 1 |
| 3. Bypass | 7. Output 2 |
| 4. GND | 8. Vcc |

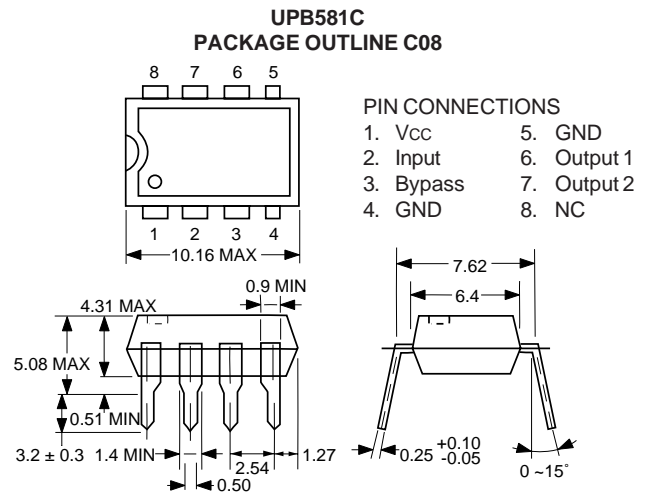

UPB581B INPUT AND OUTPUT S-PARAMETERS

Vcc = 5.0 V, Icc = 30 mA

Freq (GHz)	S11		Freq (GHz)	S22	
	MAG	ANG		MAG	ANG
0.20	0.732	-16	0.10	0.174	168
0.40	0.713	-32	0.20	0.207	138
0.60	0.691	-47	0.30	0.227	114
0.80	0.674	-62	0.40	0.257	96
1.00	0.659	-77	0.50	0.284	81
1.20	0.655	-92	0.60	0.310	67
1.40	0.642	-108	0.70	0.332	55
1.60	0.617	-125	0.80	0.347	41
1.80	0.583	-142	0.90	0.377	33
2.00	0.537	-159	1.00	0.367	17
2.20	0.488	-176	1.10	0.386	11
2.40	0.435	167	1.20	0.389	-10
2.60	0.377	149	1.30	0.406	-10
2.80	0.305	132	1.40	0.363	-28
3.00	0.245	115	1.50	0.428	-30

INTERNAL SCHEMATIC

