

BIPOLAR ANALOG INTEGRATED CIRCUIT

μ PC4072

LOW NOISE J-FET INPUT DUAL OPERATIONAL AMPLIFIER

DESCRIPTION

The J-FET input operational amplifier of the μ PC4072 is designed as low noise version of the μ PC4082. The features of the μ PC4072 are more improved input equivalent noise voltage, input offset voltage and input bias current than those of μ PC4082. By these features, the μ PC4072 is excellent choice for wide variety of applications including audio preamplifier and active filter.

FEATURES

- Low noise: $e_n = 18 \text{ nV}/\sqrt{\text{Hz}}$ (TYP.)
- Very low input bias and offset currents
- Output short circuit protection
- High input impedance...J-FET Input stage
- Internal frequency compensation
- High slew rate...13 V/ μ s (TYP.)

EQUIVALENT CIRCUIT

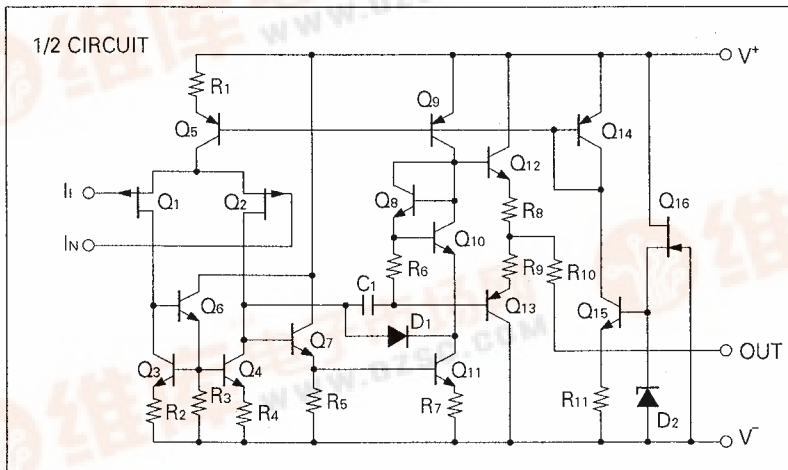

CONNECTION DIAGRAM (Top View)

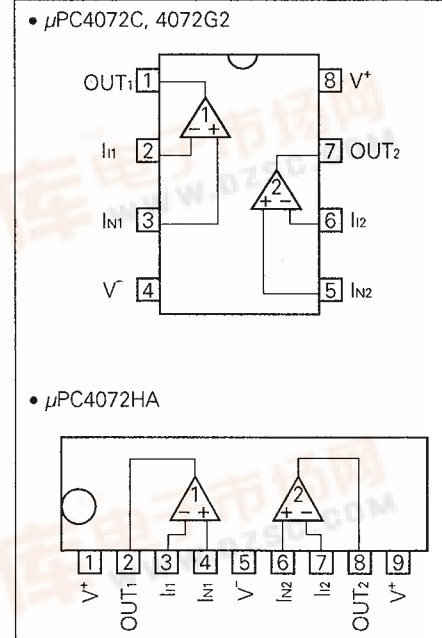

ORDERING INFORMATION

PART NUMBER	PACKAGE	QUALITY GRADE
μ PC4072C	8 PIN PLASTIC DIP (300 mil)	Standard
μ PC4072G2	8 PIN PLASTIC SOP (225 mil)	Standard
μ PC4072HA	9 PIN SLIM SIP	Standard

Please refer to "Quality grade on NEC Semiconductor Devices" (Document number IEI-1209) published by NEC Corporation to know the specification of quality grade on the devices and its recommended applications.

ABSOLUTE MAXIMUM RATINGS (T_a = 25 °C)

PARAMETER		SYMBOL	μPC4072	UNIT
Voltage between V ⁺ and V ⁻ (Note 1)		V ⁺ -V ⁻	-0.3 to +36	V
Differential Input Voltage		V _{ID}	±30	V
Input Voltage (Note 2)		V _I	V ⁻ -0.3 to V ⁺ +0.3	V
Output Voltage (Note 3)		V _O	V ⁻ -0.3 to V ⁺ +0.3	V
Power Dissipation	C Package (Note 4)	P _T	350	mW
	G2 Package (Note 5)		440	mW
	HA Package (Note 4)		350	mW
Output Short Circuit Duration (Note 6)			Indefinite	sec
Operating Temperature Range		T _{opt}	-20 to + 80	°C
Storage Temperature Range		T _{stg}	-55 to + 125	°C

Note 1. Reverse connection of supply voltage can cause destruction.

Note 2. The input voltage should be allowed to input without damage destruction. Even during the transition period of supply voltage, power on/off etc., this specification should be kept. The normal operation will establish when the both inputs are within the Common Mode Input Voltage Range of electrical characteristics.

Note 3. This specification is the voltage which should be allowed to supply to the output terminal from external without damage or destructive. Even during the transition period of supply voltage, power on/off etc., this specification should be kept. The output voltage of normal operation will be the Output Voltage Swing of electrical characteristics.

Note 4. Thermal derating factor is -5.0 mV/°C when ambient temperature is higher than 55 °C.

Note 5. Thermal derating factor is -4.4 mV/°C when ambient temperature is higher than 25 °C.

Note 6. Pay careful attention to the total power dissipation not to exceed the absolute maximum ratings, Note 4 and Note 5.

RECOMMENDED OPERATING CONDITIONS

CHARACTERISTIC	SYMBOL	MIN.	TYP.	MAX.	UNIT
Supply Voltage	V [±]	± 5		± 16	V
Output Current	I _o			± 10	mA
Capacitive Load (A _v = +1)	C _L			100	pF

ELECTRICAL CHARACTERISTICS (T_a = 25 °C, V[±] = ±15 V)

CHARACTERISTIC	SYMBOL	MIN.	TYP.	MAX.	UNIT	CONDITION
Input Offset Voltage	V _{io}		±3	±10.0	mV	R _s ≤ 50 Ω
Input Offset Current (Note 7)	I _{io}		±5	±50	pA	
Input Bias Current (Note 7)	I _b		30	200	pA	
Large Signal Voltage Gain	A _v	25	200		V/mV	R _L ≥ 2 kΩ, V _o = ±10 V
Supply Current	I _{cc}		4	5.0	mA	I _o = 0 A, Both Amplifiers
Common Mode Rejection Ratio	CMR	70	86		dB	
Supply Voltage Rejection Ratio	SVR	70	86		dB	
Output Voltage Swing	V _{om}	±12	+13.5		V	R _L ≥ 10 kΩ
Output Voltage Swing	V _{om}	±10	±12		V	R _L ≥ 2 kΩ
Common Mode Input Voltage Range	V _{ICM}	±10			V	
Slew Rate	SR		13		V/μs	A _v = 1
Unity Gain Frequency	f _{unity}		3		MHz	
Input Equivalent Noise Voltage	V _n		4		μV _{r.m.s.}	R _s = 100 Ω, f = 10 Hz to 10 kHz
Input Equivalent Noise Voltage Density	e _n		18		nV/√Hz	R _s = 100 Ω, f = 1 kHz
Channel Separation			120		dB	
Input Offset Voltage	V _{io}			±13	mV	R _s ≤ 50 Ω, T _a = -20 to +70 °C
Average V _{io} Temperature Drift	ΔV _{io} /ΔT		±10		μV/°C	T _a = -20 to +70 °C
Input Offset Current (Note 7)	I _{io}			±2	nA	T _a = -20 to +70 °C
Input Bias Current (Note 7)	I _b			7	nA	T _a = -20 to +70 °C

Note 7. Input bias currents flow into IC. Because each currents are gate leak current of P-channel J-FET on input stage.

And that are temperature sensitive. Short time measuring method is recommendable to maintain the junction temperature close to the ambient temperature.

TYPICAL PERFORMANCE CHARACTERISTICS ($T_a = 25\text{ }^\circ\text{C}$, TYP.)

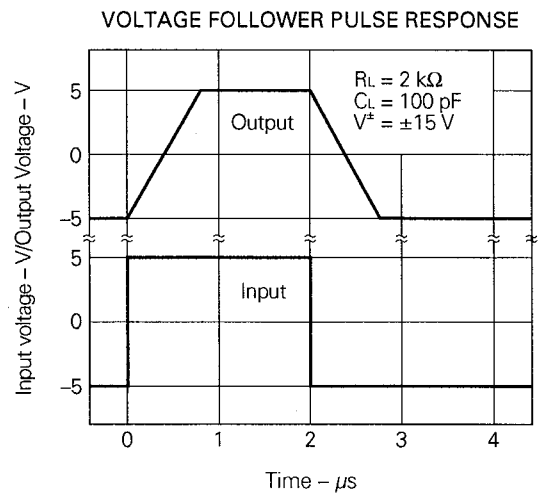
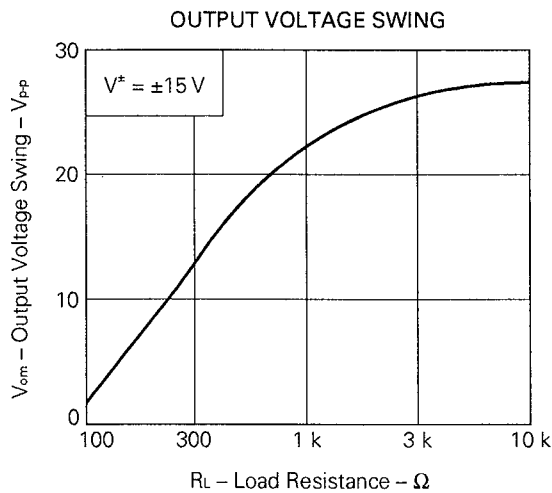
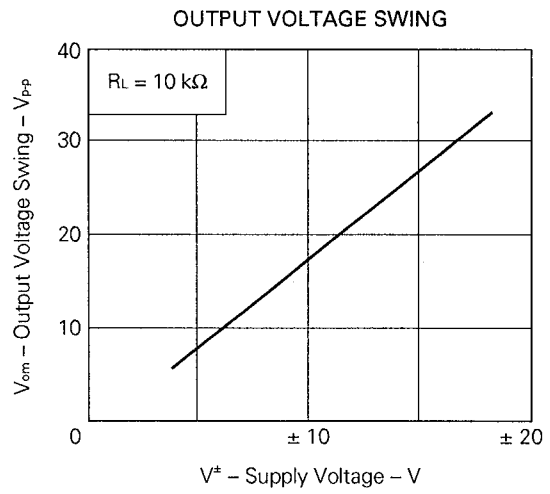
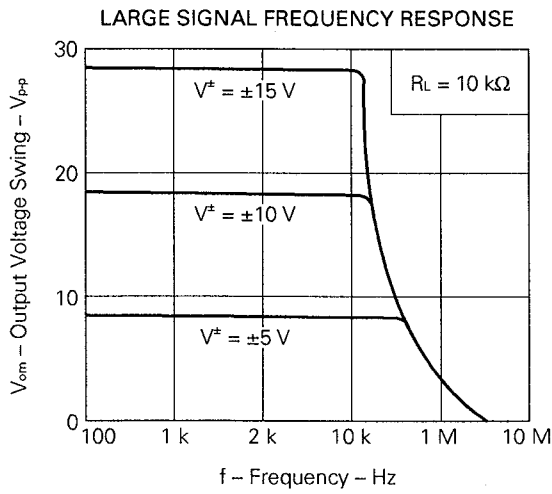
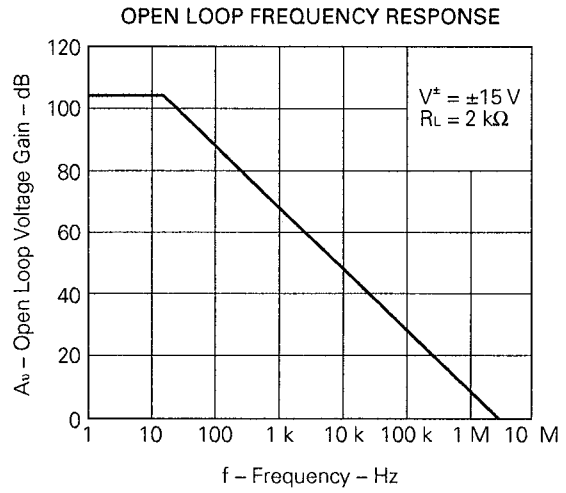
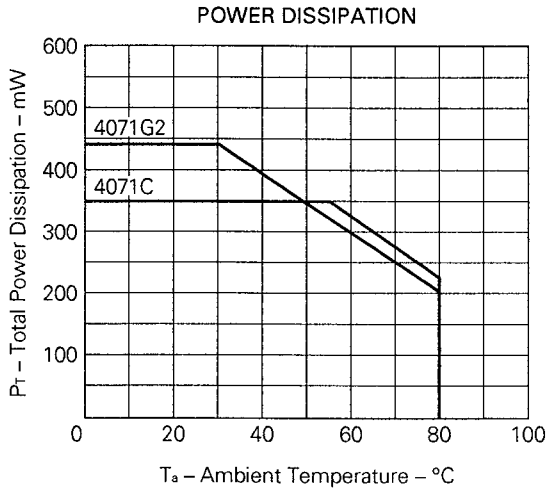

INPUT BIAS CURRENT

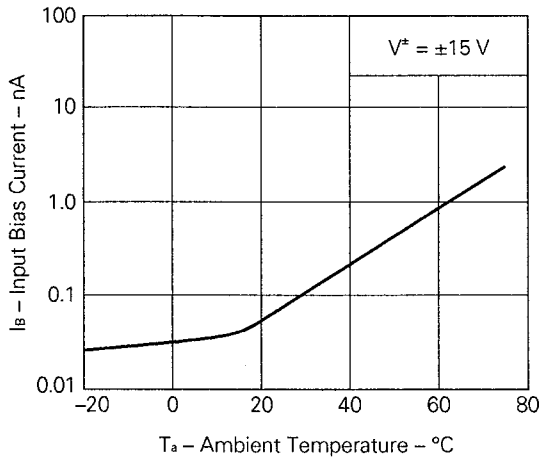

INPUT EQUIVALENT NOISE VOLTAGE DENSITY

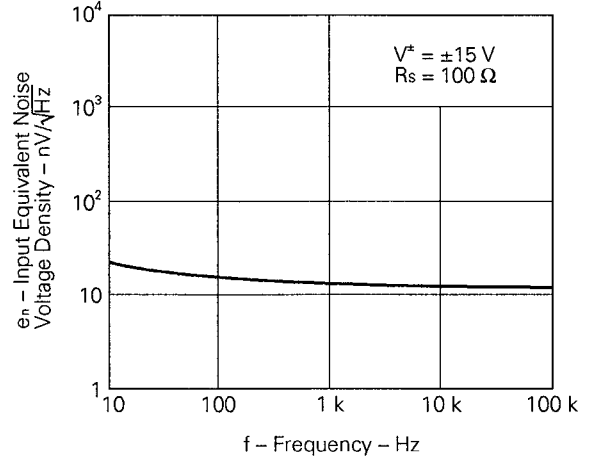

SUPPLY CURRENT

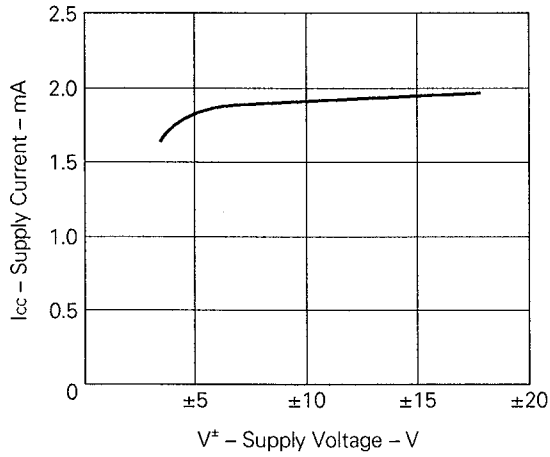

8PIN PLASTIC DIP (300 mil)

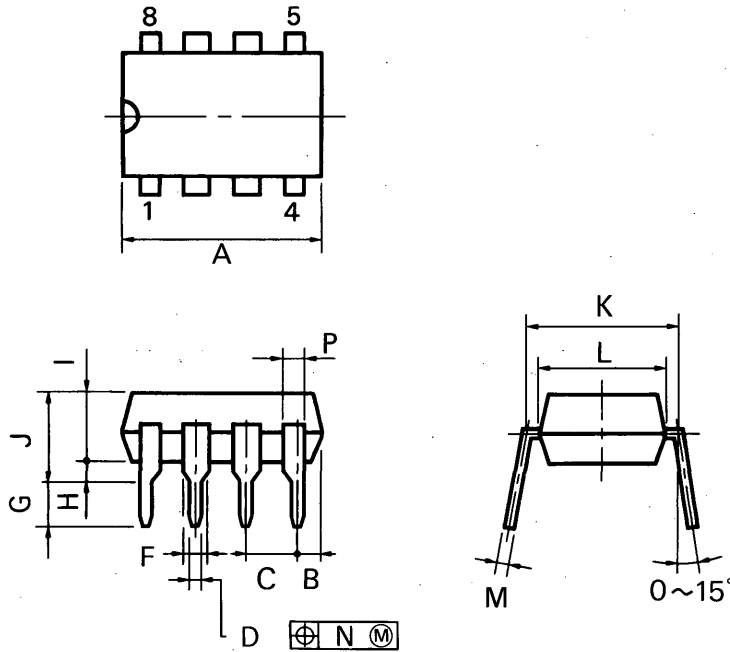

P8C-100-300B,C

NOTES

- 1) Each lead centerline is located within 0.25 mm (0.01 inch) of its true position (T.P.) at maximum material condition.
- 2) Item "K" to center of leads when formed parallel.

ITEM	MILLIMETERS	INCHES
A	10.16 MAX.	0.400 MAX.
B	1.27 MAX.	0.050 MAX.
C	2.54 (T.P.)	0.100 (T.P.)
D	0.50 ^{±0.10}	0.020 ^{+0.004} _{-0.005}
F	1.4 MIN.	0.055 MIN.
G	3.2 ^{±0.3}	0.126 ^{±0.012}
H	0.51 MIN.	0.020 MIN.
I	4.31 MAX.	0.170 MAX.
J	5.08 MAX.	0.200 MAX.
K	7.62 (T.P.)	0.300 (T.P.)
L	6.4	0.252
M	0.25 ^{+0.10} _{-0.05}	0.010 ^{+0.004} _{-0.003}
N	0.25	0.01
P	0.9 MIN.	0.035 MIN.

8 PIN PLASTIC SOP (225 mil)

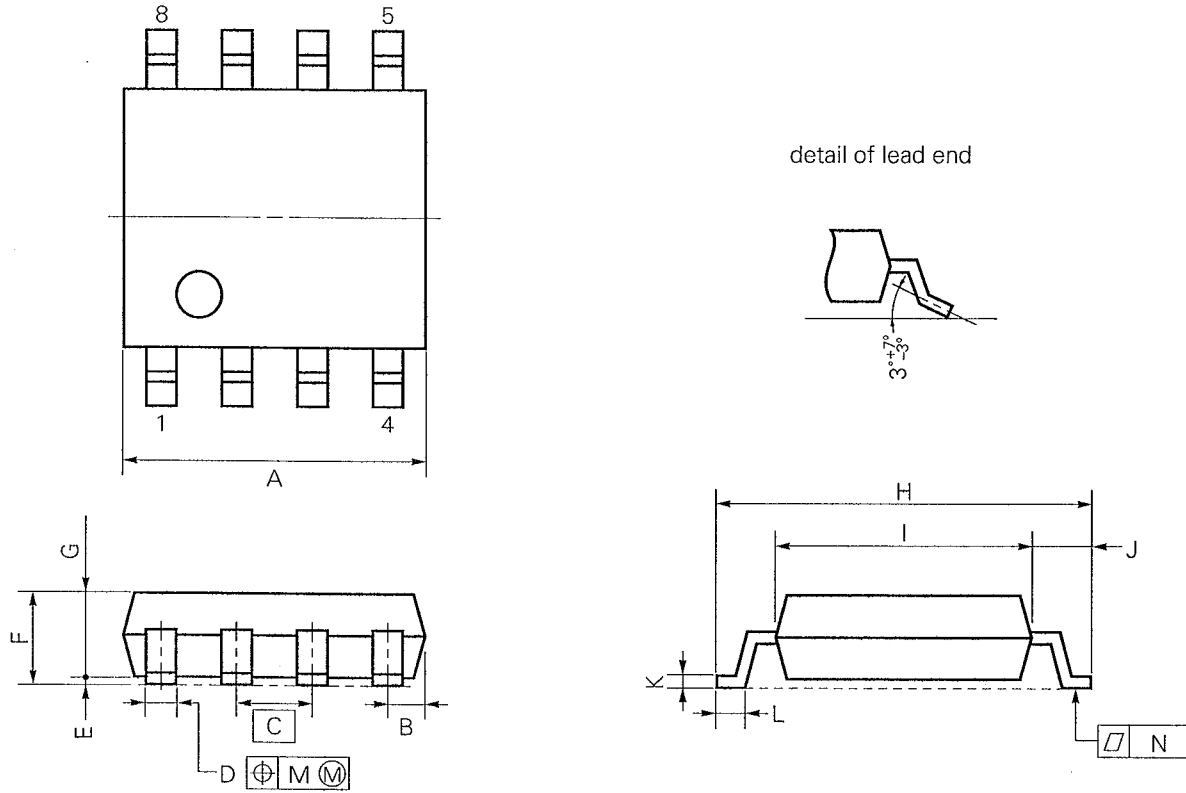

NOTE

Each lead centerline is located within 0.12 mm (0.005 inch) of its true position (T.P.) at maximum material condition.

S8GM-50-225B-2

ITEM	MILLIMETERS	INCHES
A	5.37 MAX.	0.212 MAX.
B	0.78 MAX.	0.031 MAX.
C	1.27 (T.P.)	0.050 (T.P.)
D	0.40 ^{+0.10} _{-0.05}	0.016 ^{+0.004} _{-0.003}
E	0.1±0.1	0.004±0.004
F	1.8 MAX.	0.071MAX.
G	1.49	0.059
H	6.5±0.3	0.256±0.012
I	4.4	0.173
J	1.1	0.043
K	0.15 ^{+0.10} _{-0.05}	0.006 ^{+0.004} _{-0.002}
L	0.6±0.2	0.024 ^{+0.008} _{-0.009}
M	0.12	0.005
N	0.15	0.006

9 PIN PLASTIC SLIM SIP

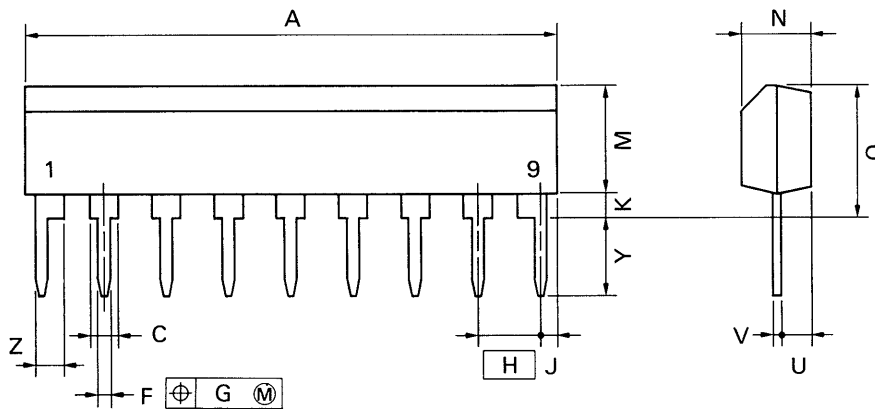

NOTE

Each lead centerline is located within 0.25 mm (0.01 inch) of its true position (T.P.) at maximum material condition.

P9HA-254B

ITEM	MILLIMETERS	INCHES
A	22.86 MAX.	0.9 MAX.
C	1.1 MIN.	0.043 MIN.
F	0.5 ^{±0.1}	0.02 ^{±0.004}
G	0.25	0.01
H	2.54	0.1
J	1.27 MAX.	0.05 MAX.
K	0.51 MIN.	0.02 MIN.
M	5.08 MAX.	0.2 MAX.
N	2.8 ^{±0.2}	0.11 ^{±0.008}
Q	5.75 MAX.	0.227 MAX.
U	1.5 MAX.	0.059 MAX.
V	0.25 ^{±0.10}	0.01 ^{±0.004}
Y	3.2 ^{±0.5}	0.126 ^{±0.02}
Z	1.1 MIN.	0.043 MIN.

RECOMMENDED SOLDERING CONDITIONS

The following conditions (see table below) must be met when soldering this product.
Please consult with our sales offices in case other soldering process is used, or in case soldering is done under different conditions.

TYPES OF SURFACE MOUNT DEVICE

For more details, refer to our document "SEMICONDUCTOR DEVICE MOUNTING TECHNOLOGY MANUAL" (IEI-1207).

[μPC4072G2]

Soldering method	Soldering conditions	Recommended condition symbol
Infrared ray reflow	Peak package's surface temperature: 230 °C or below, Reflow time: 30 seconds or below (210 °C or higher), Number of reflow process: 1, Exposure limit*: None	IR30-00-1
VPS	Peak package's surface temperature: 215 °C or below, Reflow time: 40 seconds or below (200 °C or higher), Number of reflow process: 1, Exposure limit*: None	VP15-00-1
Wave soldering	Peak package's surface temperature: 260 °C or below, Flow time: 10 seconds or below, Number of flow process: 1, Exposure limit*: None	WS15-00-1
Partial heating method	Terminal temperature: 300 °C or below, Flow time: 10 seconds or below, Exposure limit*: None	

*: Exposure limit before soldering after dry-pack package is opened.
Storage conditions: 25 °C and relative humidity at 65 % or less.

Note: Do not apply more than a single process at once, except for "Partial heating method."

TYPES OF THROUGH HOLE DEVICE

[μPC4072C, μPC4072HA]

Soldering method	Soldering conditions	Recommended condition symbol
Wave soldering	Solder temperature: 260 °C or below, Flow time: 10 seconds or below	

[MEMO]

No part of this document may be copied or reproduced in any form or by any means without the prior written consent of NEC Corporation. NEC Corporation assumes no responsibility for any errors which may appear in this document.

NEC Corporation does not assume any liability for infringement of patents, copyrights or other intellectual property rights of third parties by or arising from use of a device described herein or any other liability arising from use of such device. No license, either express, implied or otherwise, is granted under any patents, copyrights or other intellectual property rights of NEC Corporation or others.

The devices listed in this document are not suitable for use in aerospace equipment, submarine cables, nuclear reactor control systems and life support systems. If customers intend to use NEC devices for above applications or they intend to use "Standard" quality grade NEC devices for applications not intended by NEC, please contact our sales people in advance.

Application examples recommended by NEC Corporation.

Standard: Computer, Office equipment, Communication equipment, Test and Measurement equipment, Machine tools, Industrial robots, Audio and Visual equipment, Other consumer products, etc.

Special: Automotive and Transportation equipment, Traffic control systems, Antidisaster systems, Anticrime systems, etc.