

BIPOLAR ANALOG INTEGRATED CIRCUIT

μ PC4574

QUAD ULTRA LOW-NOISE, WIDEBAND, OPERATIONAL AMPLIFIER

DESCRIPTION

The μ PC4574 is an ultra low noise, high slew rate quad operational amplifier specifically designed for audio, instrumentation, and communication circuits. The low noise and high frequency capabilities make it ideal for preamps and active filters for instrumentation and professional audio.

FEATURES

- Ultra low noise
- High slew rate
- Wide bandwidth
- Internal frequency compensation

EQUIVALENT CIRCUIT (1/4 Circuit)

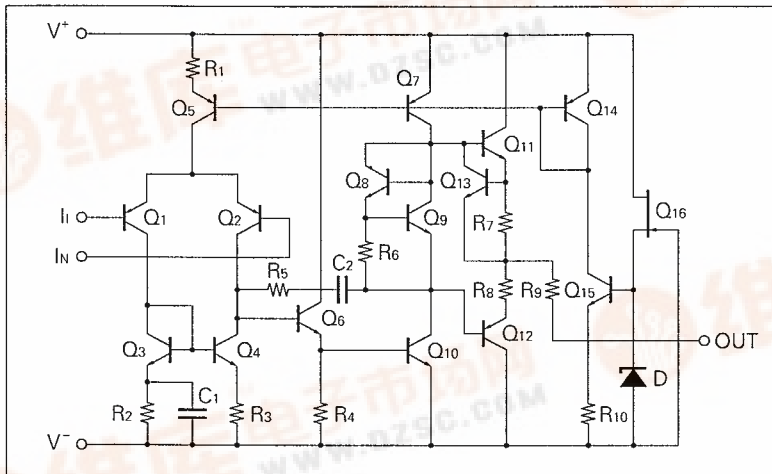

CONNECTION DIAGRAM (Top View)

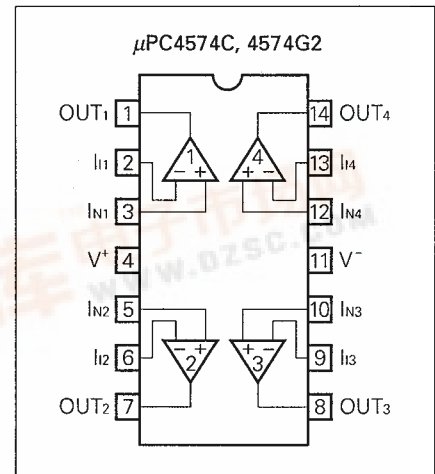

ORDERING INFORMATION

PART NUMBER	PACKAGE	QUALITY GRADE
μ PC4574C	14 PIN PLASTIC DIP (300 mil)	Standard
μ PC4574G2	14 PIN PLASTIC SOP (225 mil)	Standard

Please refer to "Quality grade on NEC Semiconductor Devices" (Document number IEI-1209) published by NEC Corporation to know the specification of quality grade on the devices and its recommended applications.

ABSOLUTE MAXIMUM RATINGS (T_a = 25 °C)

PARAMETER		SYMBOL	μPC4574	UNIT
Voltage between V ⁺ and V ⁻ (Note 1)		V ⁺ - V ⁻	-0.3 to +36	V
Differential Input Voltage		V _{ID}	±30	V
Input Voltage (Note 2)		V _I	V ⁻ -0.3 to V ⁺ +0.3	V
Output Voltage (Note 3)		V _O	V ⁻ -0.3 to V ⁺ +0.3	V
Power Dissipation	C Package (Note 4)	P _T	570	mW
	G2 Package (Note 5)		550	mW
Output Short Circuit Duration (Note 6)			10	sec
Operating Temperature Range		T _{opt}	-20 to +80	°C
Storage Temperature Range		T _{stg}	-55 to +125	°C

Note 1. Reverse connection of supply voltage can cause destruction.

Note 2. The input voltage should be allowed to input without damage or destruction. Even during the transition period of supply voltage, power on/off etc., this specification should be kept. The normal operation will establish when the both inputs are within the Common Mode Input Voltage Range of electrical characteristics.

Note 3. This specification is the voltage which should be allowed to supply to the output terminal from external without damage or destructive. Even during the transition period of supply voltage, power on/off etc., this specification should be kept. The output voltage of normal operation will be the Output Voltage Swing of electrical characteristics.

Note 4. Thermal derating factor is -7.6 mV / °C when ambient temperature is higher than 50 °C.

Note 5. Thermal derating factor is -5.5 mV / °C when ambient temperature is higher than 25 °C.

Note 6. Pay careful attention to the total power dissipation not to exceed the absolute maximum ratings, Note 4 and Note 5.

RECOMMENDED OPERATING CONDITIONS

CHARACTERISTIC	SYMBOL	MIN.	TYP.	MAX.	UNIT
Supply Voltage	V [±]	± 4		± 16	V
Output Current	I _o			± 10	mA
Source Resistance	R _s			50	kΩ
Capacitive Load (A _v = +1)	C _L			100	pF

ELECTRICAL CHARACTERISTICS (T_a = 25 °C, V[±] = ±15 V)

CHARACTERISTIC	SYMBOL	MIN.	TYP.	MAX.	UNIT	CONDITIONS
Input Offset Voltage	V _{io}		±0.3	±5	mV	R _s ≤ 50 Ω
Input Offset Current (Note 7)	I _{io}		±10	±200	nA	
Input Bias Current (Note 7)	I _b		500	1000	nA	
Large Signal Voltage Gain	A _v	30	300		V/mV	R _L ≥ 2 kΩ, V _o = ±10 V
Supply Current	I _{cc}		8.5	12	mA	I _o = 0 A, All Amplifiers
Common Mode Rejection Ratio	CMR	80	100		dB	
Supply Voltage Rejection Ratio	SVR	80	100		dB	
Output Voltage Swing	V _{om}	±12	±13.4		V	R _L ≥ 10 kΩ
		±10	±12.8			R _L ≥ 2 kΩ
Common Mode Input Voltage Range	V _{icm}	±12	±14		V	
Slew Rate	SR	4	6		V/μs	R _L ≥ 2 kΩ
Gain Band Width Product	GBW	10	14		MHz	f _o = 100 kHz
Unity Gain Frequency	f _{unity}		7		MHz	open loop
Phase Margin	φ _{unity}		50		degree	open loop
Total Harmonic Distortion	THD		0.002		%	V _o = 3 V _{r.m.s.} , f = 20 Hz to 20 kHz (Fig.1)
Input Equivalent Noise Voltage	V _n		1.2		μV _{r.m.s.}	RIAA (Fig.2)
			0.53	0.65		FLAT + JIS A, R _s = 100 Ω (Fig.3)
Input Equivalent Noise Voltage Density	e _n		5.5		nV/√Hz	f _o = 10 Hz, R _s = 100 Ω
			5.0			f _o = 1 kHz, R _s = 100 Ω
Input Equivalent Noise Current Density	i _n		0.7		pA/√Hz	f _o = 1 kHz
Channel Separation			120		dB	f = 20 Hz to 20 kHz

Note 7. Input bias currents flow out from IC. Because each currents are base current of PNP-transistor on input stage.

MEASUREMENT CIRCUIT

Fig. 1 Total Harmonic Distortion Measurement Circuit

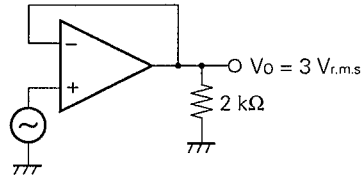

Fig. 2 Noise Measurement Circuit (RIAA)

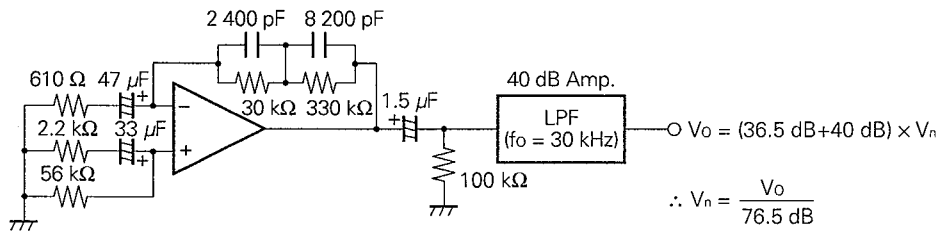
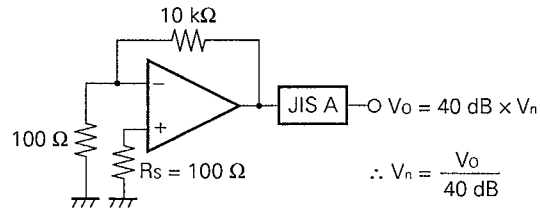
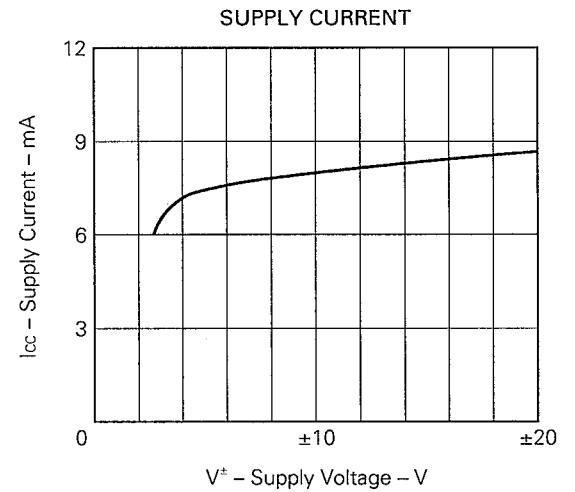
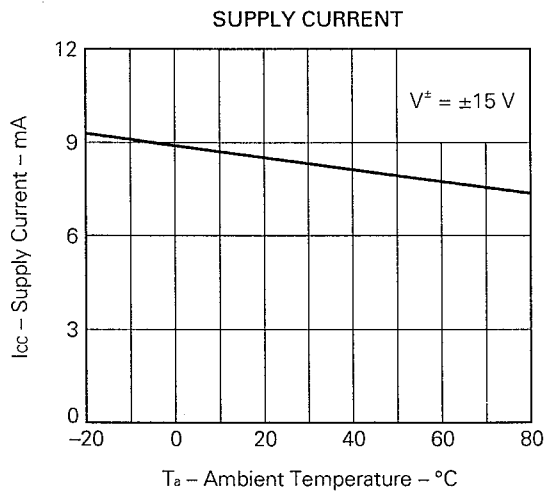
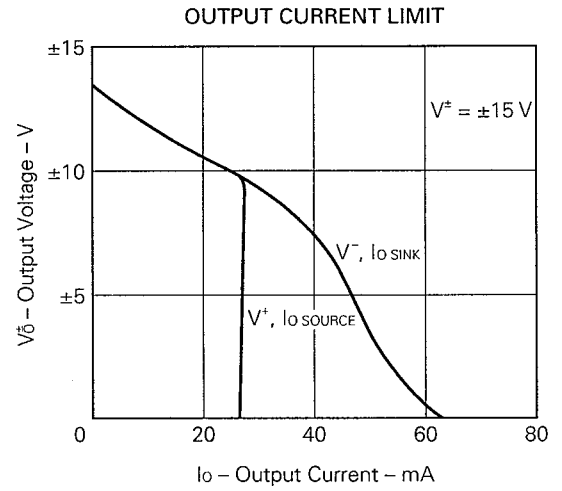
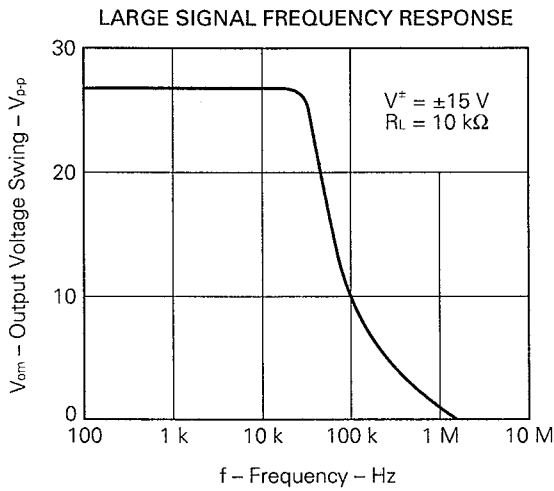
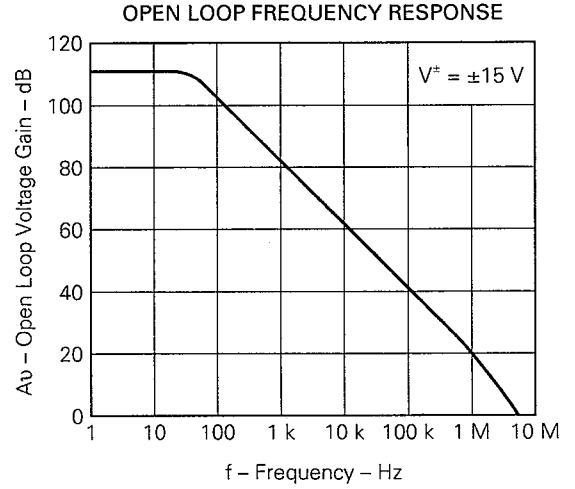
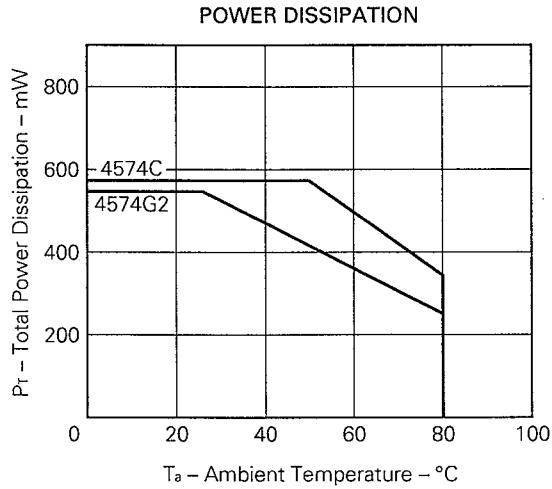
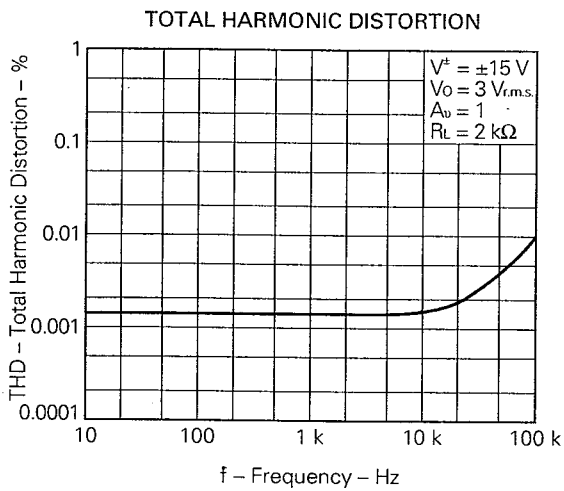
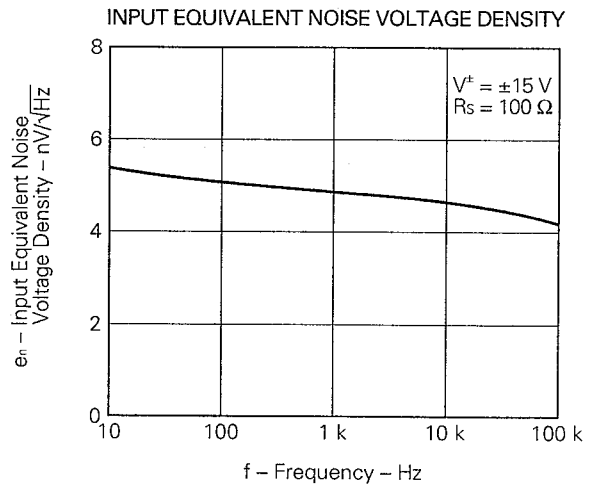
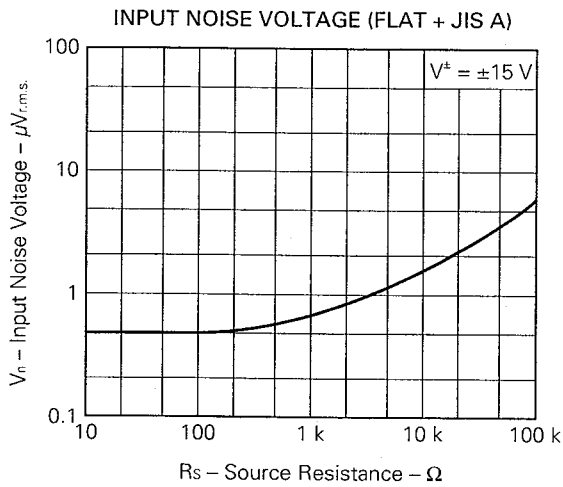
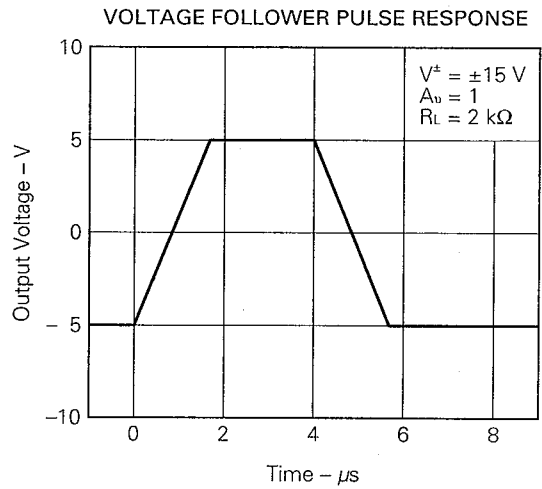
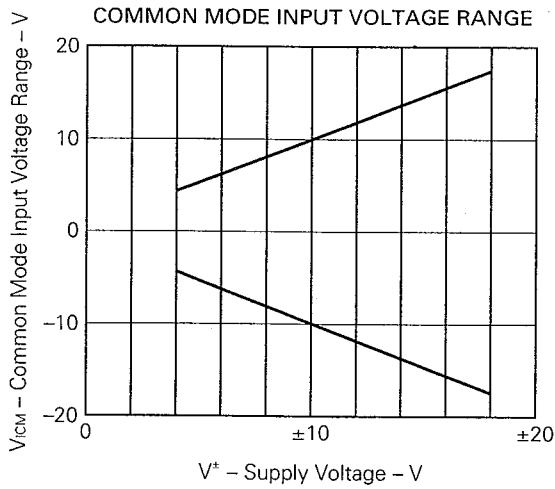

Fig. 3 Flat Noise Measurement Circuit (FLAT + JIS A)



TYPICAL PERFORMANCE CHARACTERISTICS ($T_a = 25^\circ\text{C}$, TYP.)





14PIN PLASTIC DIP (300 mil)

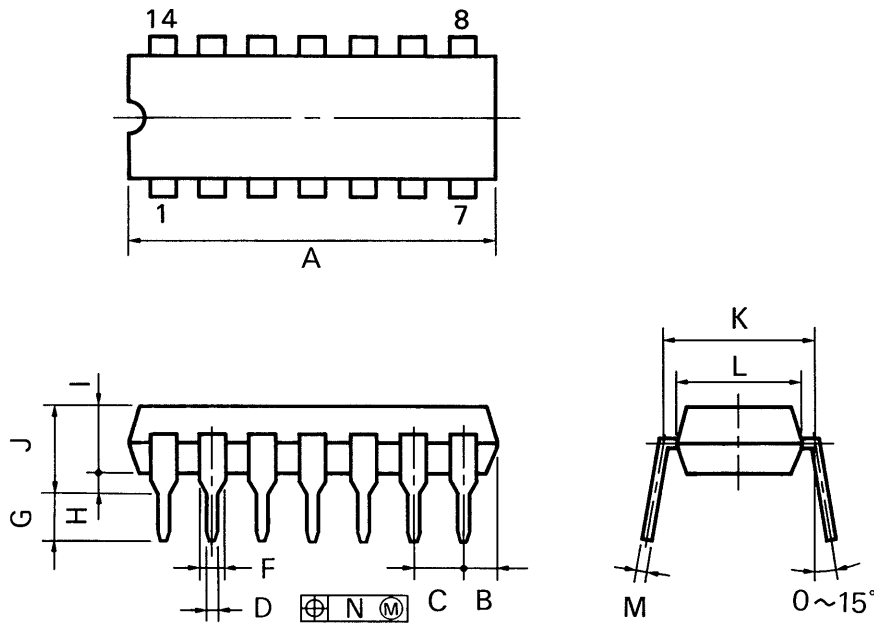

P14C-100-300B1

NOTES

- 1) Each lead centerline is located within 0.25 mm (0.01 inch) of its true position (T.P.) at maximum material condition.
- 2) Item "K" to center of leads when formed parallel.

ITEM	MILLIMETERS	INCHES
A	20.32 MAX.	0.800 MAX.
B	2.54 MAX.	0.100 MAX.
C	2.54 (T.P.)	0.100 (T.P.)
D	0.50 ±0.10	0.020 ±0.004
F	1.2 MIN.	0.047 MIN.
G	3.6 ±0.3	0.142 ±0.012
H	0.51 MIN.	0.020 MIN.
I	4.31 MAX.	0.170 MAX.
J	5.08 MAX.	0.200 MAX.
K	7.62 (T.P.)	0.300 (T.P.)
L	6.4	0.252
M	0.25 ±0.10	0.010 ±0.004
N	0.25	0.01

14 PIN PLASTIC SOP (225 mil)

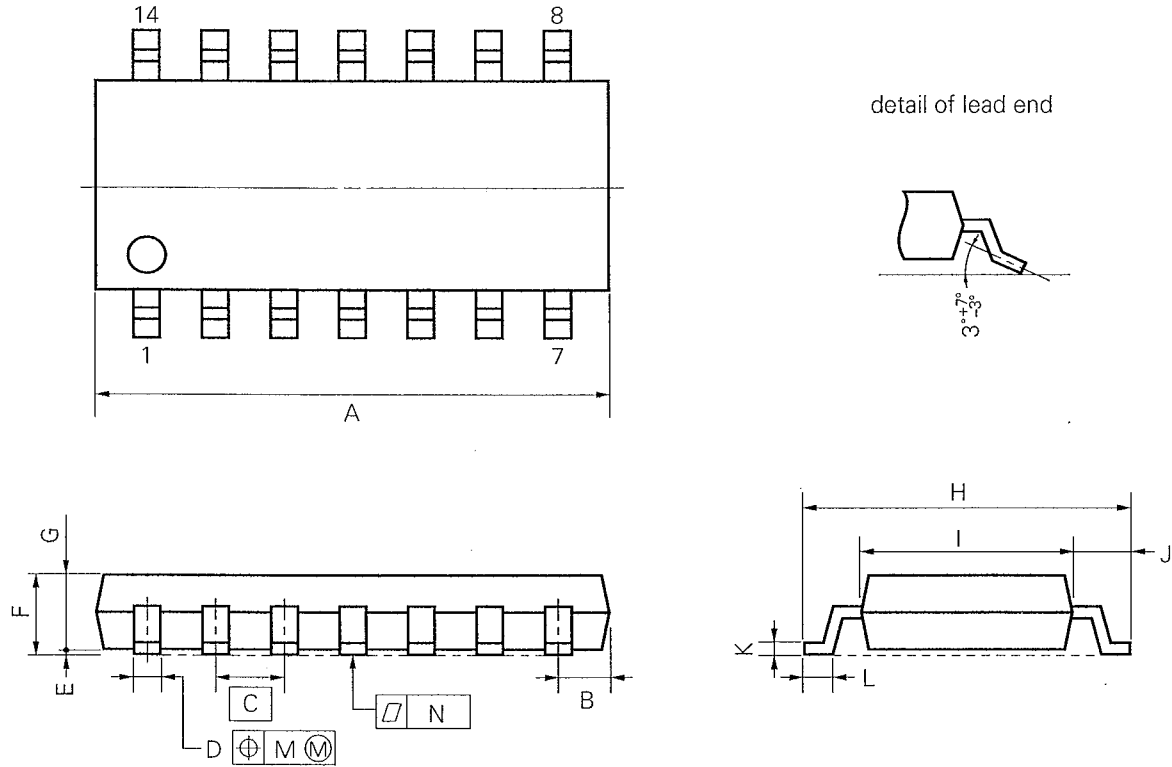

NOTE

Each lead centerline is located within 0.12 mm (0.005 inch) of its true position (T.P.) at maximum material condition.

S14GM-50-225B, C-2

ITEM	MILLIMETERS	INCHES
A	10.46 MAX.	0.412 MAX.
B	1.42 MAX.	0.056 MAX.
C	1.27 (T.P.)	0.050 (T.P.)
D	0.40 ^{+0.10} _{-0.05}	0.016 ^{+0.004} _{-0.003}
E	0.1±0.1	0.004±0.004
F	1.8 MAX.	0.071 MAX.
G	1.49	0.059
H	6.5±0.3	0.256±0.012
I	4.4	0.173
J	1.1	0.043
K	0.15 ^{+0.10} _{-0.05}	0.006 ^{+0.004} _{-0.002}
L	0.6±0.2	0.024 ^{+0.008} _{-0.009}
M	0.12	0.005
N	0.15	0.006

RECOMMENDED SOLDERING CONDITIONS

The following conditions (see table below) must be met when soldering this product.
Please consult with our sales offices in case other soldering process is used, or in case soldering is done under different conditions.

TYPES OF SURFACE MOUNT DEVICE

For more details, refer to our document "SEMICONDUCTOR DEVICE MOUNTING TECHNOLOGY MANUAL" (IEI-1207).

[μPC4574G2]

Soldering method	Soldering conditions	Recommended condition symbol
Infrared ray reflow	Peak package's surface temperature: 230 °C or below, Reflow time: 30 seconds or below (210 °C or higher), Number of reflow process: 1, Exposure limit*: None	IR30-00-1
VPS	Peak package's surface temperature: 215 °C or below, Reflow time: 40 seconds or below (200 °C or higher), Number of reflow process: 1, Exposure limit*: None	VP15-00-1
Wave soldering	Solder temperature: 260 °C or below, Flow time: 10 seconds or below Number of flow process: 1, Exposure limit*: None	WS15-00-1
Partial heating method	Terminal temperature: 300 °C or below, Flow time: 10 seconds or below, Exposure limit*: None	

*: Exposure limit before soldering after dry-pack package is opened.
Storage conditions: 25 °C and relative humidity at 65 % or less.

Note: Do not apply more than a single process at once, except for "Partial heating method."

TYPES OF THROUGH HOLE DEVICE

[μPC4574C]

Soldering method	Soldering conditions	Recommended condition symbol
Wave soldering	Solder temperature: 260 °C or below, Flow time: 10 seconds or below	

[MEMO]

No part of this document may be copied or reproduced in any form or by any means without the prior written consent of NEC Corporation. NEC Corporation assumes no responsibility for any errors which may appear in this document.

NEC Corporation does not assume any liability for infringement of patents, copyrights or other intellectual property rights of third parties by or arising from use of a device described herein or any other liability arising from use of such device. No license, either express, implied or otherwise, is granted under any patents, copyrights or other intellectual property rights of NEC Corporation or others.

The devices listed in this document are not suitable for use in aerospace equipment, submarine cables, nuclear reactor control systems and life support systems. If customers intend to use NEC devices for above applications or they intend to use "Standard" quality grade NEC devices for applications not intended by NEC, please contact our sales people in advance.

Application examples recommended by NEC Corporation.

Standard: Computer, Office equipment, Communication equipment, Test and Measurement equipment, Machine tools, Industrial robots, Audio and Visual equipment, Other consumer products, etc.

Special: Automotive and Transportation equipment, Traffic control systems, Antidisaster systems, Anticrime systems, etc.