

NEC

RX-IF SiMMIC FOR W-CDMA AGC + I/Q DEMODULATOR

UPC8190K

FEATURES

- **Rx-IF:**
380 MHz
- **LOW POWER CONSUMPTION:**
 $V_{CC} = 3.0\text{ V}$
- **SMALL 20 PIN QFN PACKAGE**
Flat lead style for better performance
- **TAPE AND REEL PACKAGING AVAILABLE**

DESCRIPTION

The UPC8190K is a Silicon Monolithic Integrated Circuit designed as a receiver (RX) section for W-CDMA. The UPC8190K is a RX-IF IC including IF-AGC amplifier and demodulator. This IC is suitable for kit-use for W-CDMA IF section.

This IC was developed using NEC's new ultra high speed silicon bipolar process.

NEC's stringent quality assurance and test procedures ensure the highest reliability and performance.

BLOCK DIAGRAM

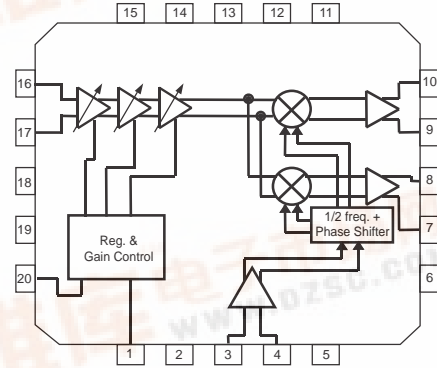

APPLICATIONS

- W-CDMA

ELECTRICAL CHARACTERISTICS (unless otherwise specified, $T_A = 25^\circ\text{C}$, $V_{CC} = 3.0\text{ V}$, $f_{IF} = 382.5\text{ MHz}$, $f_{LO} = 760\text{ MHz}$, $P_{LO} = -15\text{ dBm}$, $f_{I/Q} = 2.5\text{ MHz}$)

PART NUMBER PACKAGE OUTLINE			UP8190K QFN-20		
SYMBOLS	PARAMETERS AND CONDITIONS	UNITS	MIN	TYP	MAX
I _{CC}	Circuit Current, no signals at power saving mode	mA	-	9	12
		μA	-	-	1
V _{G1}	Voltage Gain, $V_{CONT} = 2.5\text{ V}$	dB	68	77	-
V _{G2}	$V_{CONT} = 0.5\text{ V}$	dB	-	-20	-15
IIP3	Third Order Input Intercept Point, $R_s = 600\Omega$ balanced, Gain = +65 dB $P_{IN} = -70\text{ dB}$ Gain = -10 dB $P_{IN} = -10\text{ dB}$	dBm	-60	-55	-
			0	3	-
LoL	Local Leakage, Leakage to I/Q port when local = 760 MHz and output = 30mV _{p-p} balanced	dBc	-	-	20
BW(I/Q)	I/Q Bandwidth, 3 dB down	MHz	10	-	-
V _{OUT(SAT)}	I/Q Maximum output swing, Balanced output	V _{p-p}	1	-	-
AE	I/Q Gain Balance, $f_{I/Q} = 2.5\text{ MHz}$	dB	-	-	Δ0.5
PE	I/Q Phase Error, $f_{I/Q} = 2.5\text{ MHz}$	deg	-	-	±4
GACC	Gain Accuracy, $V_{CONT} = 1\text{ to }2\text{ V}$	dB/V	-	Δ 4.6	Δ 6
TPS(Rise)	Rise time from power-saving mode	us	-	-	20
VPS(Rise)	Rising voltage from power-saving mode	V	2.2	-	-
VPS(Fall)	Falling voltage from power-saving mode	V	-	-	0.5
	Gain Flatness, $f_{IF} \pm 2.5\text{ MHz}$	dB	-	-	Δ 0.5



UPC8190K

STANDARD CHARACTERISTICS FOR REFERENCE

(unless otherwise specified, $T_A = 25^\circ\text{C}$, $V_{CC} = 3.0\text{ V}$,

$f_{IF} = 382.5\text{ MHz}$, $f_{LO} = 760\text{ MHz}$, $P_{LO} = -15\text{ dBm}$, $f_{I/Q} = 2.5\text{ MHz}$)

PART NUMBER PACKAGE OUTLINE			UP8190K QFN-20		
SYMBOLS	PARAMETERS AND CONDITIONS	UNITS	MIN	TYP	MAX
NF	Noise Figure, Gain = +65 dB	dB	-	9.5	12
EVM	Error Vector Magnitude, IF = 380 MHz, 3.84 Msps QPSK modulation, Gain is adjusted.	%rms	-	3	-
P1dB	Input Power at 1 dB compression point at Gain = +50 dB	dBm	-	-45	-

ABSOLUTE MAXIMUM RATINGS¹($T_A = 25^\circ\text{C}$)

SYMBOLS	PARAMETERS	UNITS	RATINGS
V _{CC}	Supply Voltage	V	4.0
V _{PS} , V _{CONT}	Applied Voltage	V	-0.3 to V _{CC} +0.3
T _a	Operating Ambient Temperature	°C	-40 to +85
T _{STG}	Storage Temperature	°C	-55 to +150

Notes:

- Operation in excess of any one of these parameters may result in permanent damage.

RECOMMENDED OPERATING CONDITIONS

SYMBOLS	PARAMETERS	UNITS	MIN	TYP	MAX
V _{CC}	Supply Voltage	V	2.7	2.85	3.3
T _A	Operating Ambient Temperature	°C	-25	+25	+85
f _{IF}	IF Frequency	MHz	-	380	-
f _{LO}	Local Frequency	MHz	-	760	-
P _{LO}	Local Input Level	dBm	-18	-15	-12
Z _{I/Q}	I/Q Load Impedance	kΩ	10	20	-

ORDERING INFORMATION

Part Number	Package
UPC8190K-E1	20 Pin plastic QFN

BLOCK DIAGRAM (Units in mm)

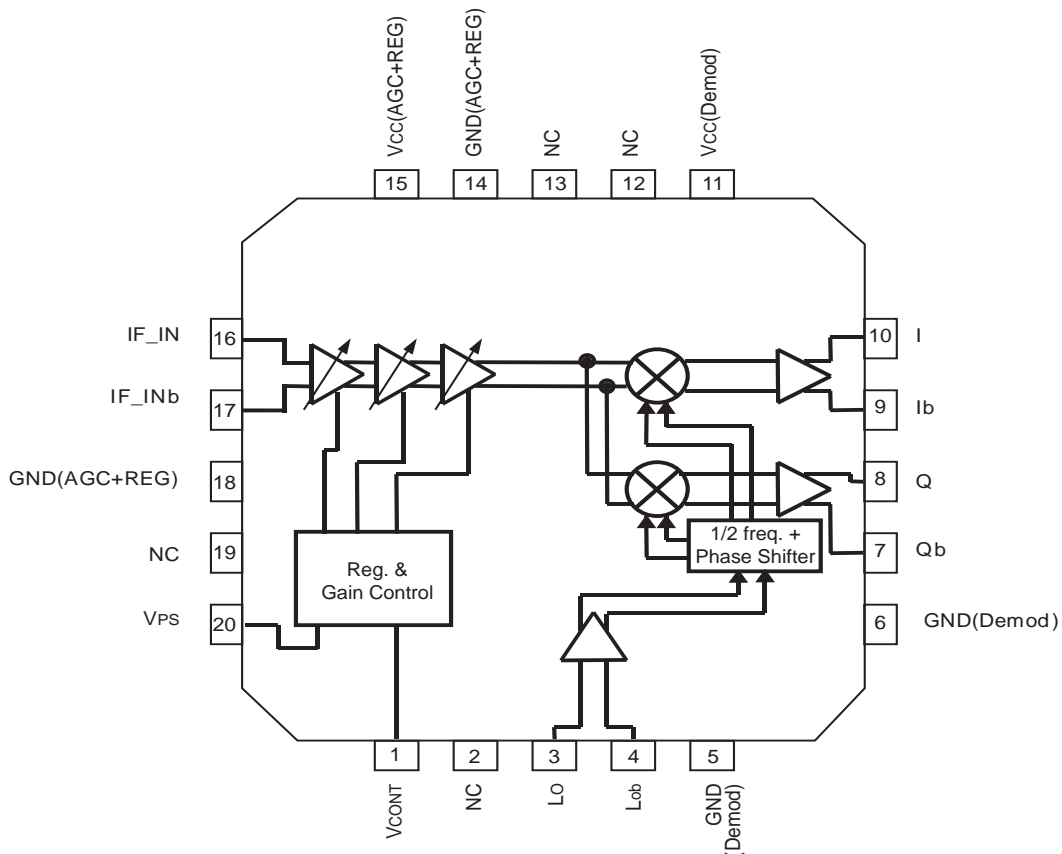

PIN FUNCTIONS (Pin Voltage is measured at Vcc = 3.0 V)

Pin No.	Pin Name	Applied Voltage (V)	Pin Voltage (V)	Functions and Applications	Internal Equivalent Circuits
1	Vcont	0 to 3.0	-	Gain control pin of AGC amplifier. Variable gains are available in accordance with applied voltage.	
2 19	N.C.	-	-	Non connection. This pin is not connected to internal circuit. This pin should be opened or grounded.	—
3	LO	-	-	Local signal input pin of I/Q demodulator. Input frequency is 760 MHz.	
4	LOb	-	-	Bypass pin of local signal input for I/Q demodulator. In the case of single local input, this pin must be decoupled with capacitor ex. 100 to 1 000 pF.	
5 6	GND (Demod.)	0	-	Ground pin of I/Q demodulator. This pin should be grounded with minimum inductance. Form the ground pattern as widely as possible to minimize ground impedance.	
7	Qb	-	-	I/Q/Ib/Qb signal output pins.	
8	Q	-	-	Each pin is an emitter follower.	
9	Ib	-	-	Each of Ib and Qb is differential output of I and Q.	
10	I	-	-	Recommendable load impedance is 10 to 20 kΩ.	
11	VCC (Demod.)	2.7 to 3.3	-	Supply voltage pin of I/Q demodulator (phase shifter + I/Q Mixer).	—
12	TEST 1	0	-	TEST pin. In actual use, this pin should be grounded.	—
13	TEST 2	0	-		—
14 18	GND (AGC, REG.)	0	-	Ground pin of AGC amplifier and internal regulator. This pin should be grounded with minimum inductance. Form the ground pattern as widely as possible to minimize ground impedance.	—

UPC8190K

PIN FUNCTIONS (Pin Voltage is measured at Vcc = 3.0 V)

Pin No.	Pin Name	Applied Voltage (V)	Pin Voltage (V)	Functions and Applications	Internal Equivalent Circuits					
15	VCC (AGC, REG.)	2.7 to 3.3	-	Supply voltage pin of AGC amplifier and internal regulator.	—					
16	IF_IN	-	-	IF signal input pin. This pin is input of AGC amplifier. Balance input between 16, 17 pin. Input frequency is 380 MHz.						
17	IF_INb	-	-	IF signal input pin. In the case of signal local input, this pin must be decoupled with capacitor.						
20	VPS	H: 2.2 to VCC L: 0 to 0.5	-	Power saving pin. This pin modulator can control Active/Sleep state with bias as follows.						
				<table border="1"> <thead> <tr> <th>VPS (V)</th> <th>State</th> </tr> </thead> <tbody> <tr> <td>0 to 0.5</td> <td>Sleep Mode</td> </tr> <tr> <td>2.2 to 3</td> <td>Active Mode</td> </tr> </tbody> </table>		VPS (V)	State	0 to 0.5	Sleep Mode	2.2 to 3
VPS (V)	State									
0 to 0.5	Sleep Mode									
2.2 to 3	Active Mode									

MEASUREMENT CIRCUIT (Units in mm)

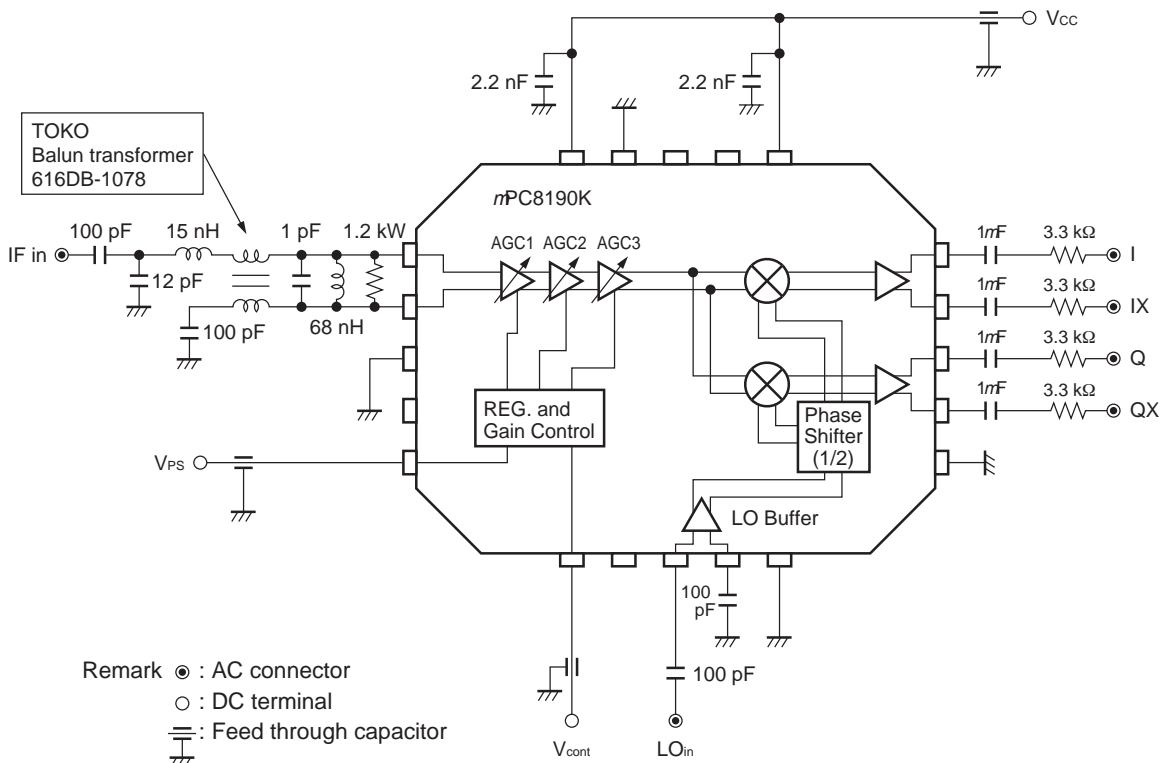

APPLICATION EXAMPLE: W-CDMA

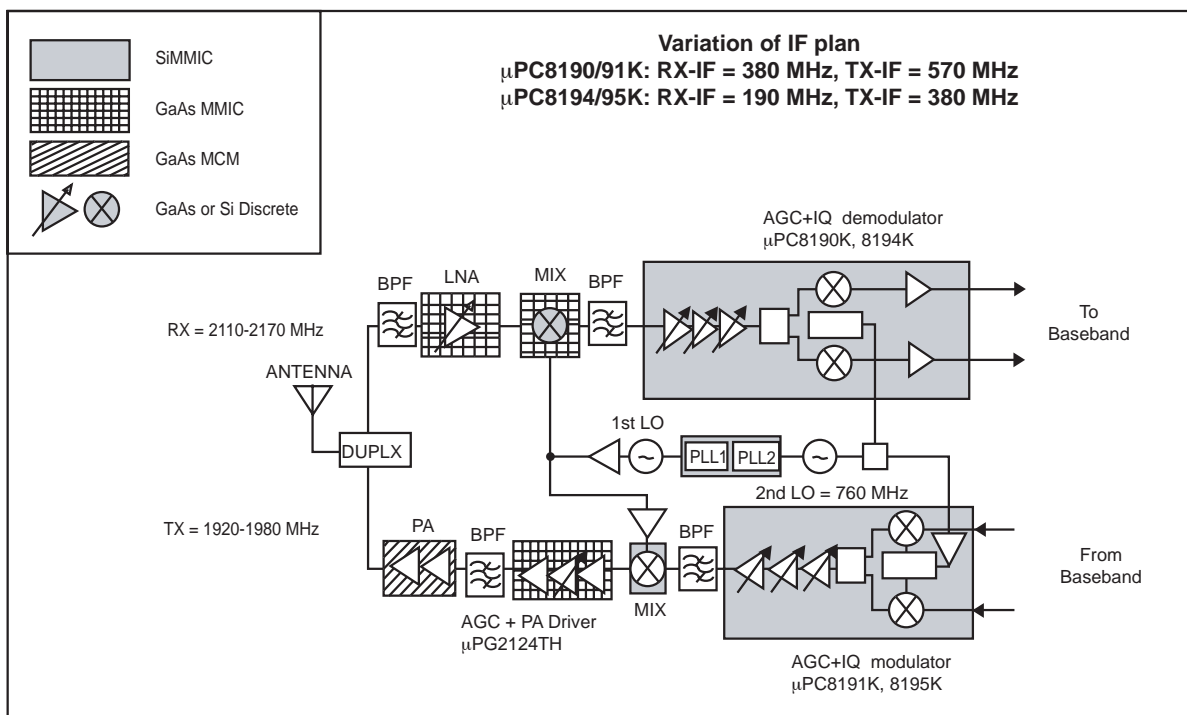

OUTLINE DIMENSIONS (Units in mm)

Package Outline QFN-20

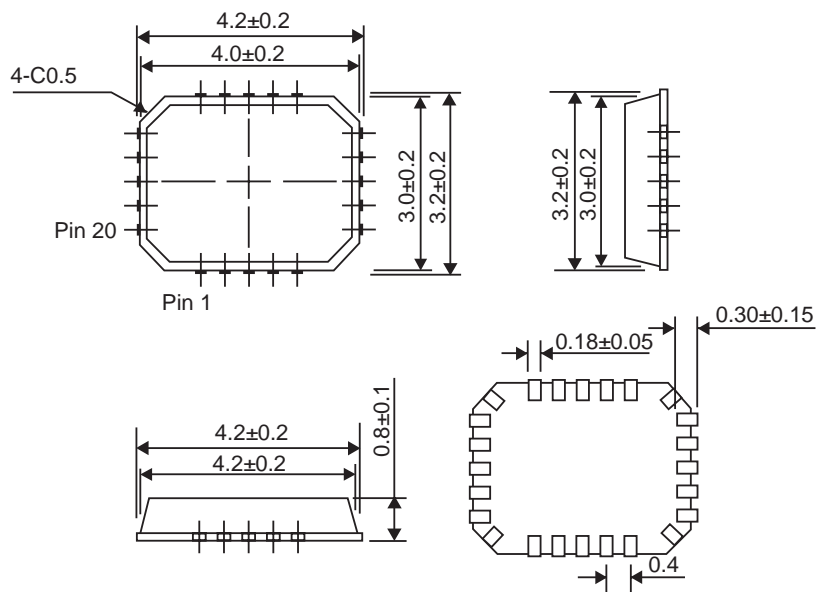

Life Support Applications

These NEC products are not intended for use in life support devices, appliances, or systems where the malfunction of these products can reasonably be expected to result in personal injury. The customers of CEL using or selling these products for use in such applications do so at their own risk and agree to fully indemnify CEL for all damages resulting from such improper use or sale.