



# MOS INTEGRATED CIRCUIT

# $\mu$ PD7001

## 8-BIT CMOS SERIAL I/O ANALOG-TO-DIGITAL CONVERTER

The  $\mu$ PD7001 is a high performance, low power 8-bit CMOS A/D converter which consists of a 4-channel analog multiplexer and a digital interface circuit for serial data I/O. It uses successive approximation as a conversion technique.

An A/D conversion system can be easily designed with the  $\mu$ PD7001 including all circuits for A/D conversion. The  $\mu$ PD7001 can be directly connected to 8-bit or 4-bit microprocessors.

### FEATURES

- Single chip A/D converter
- Resolution: 8-bit
- 4-channel analog multiplexer
- Auto-zeroscale and auto-fullscale corrections without any external components
- Serial data transmission
- High input impedance: 1 000 M $\Omega$
- Single +5 V power supply
- Low power operation
- Available in 16-pin plastic DIP
- Conversion speed: 140  $\mu$ s TYP.
- Linearity: 0.8 %

### ORDERING INFORMATION

| Ordering Code | Package                      |
|---------------|------------------------------|
| $\mu$ PD7001C | 16-pin plastic DIP (300 mil) |



BLOCK DIAGRAM

CONNECTION DIAGRAM (Top View)

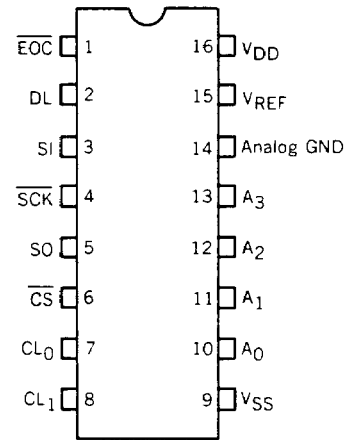
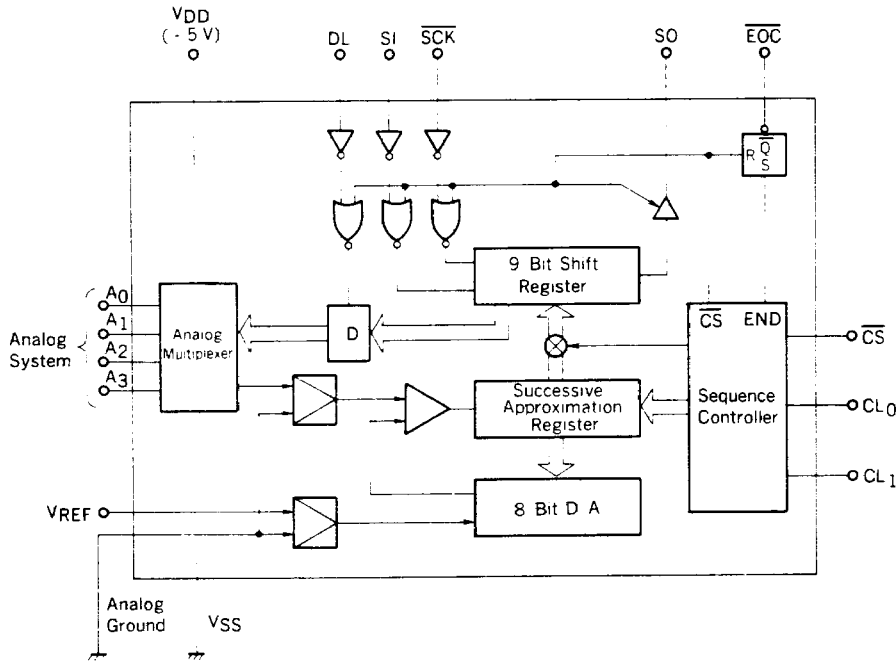

PIN IDENTIFICATION

| PIN     |                   | SYMBOL                           | FUNCTION  |
|---------|-------------------|----------------------------------|---|
| NO.     | NAME              |                                  |   |
| 1       | End of Conversion | EOC                              | High impedance when $\overline{CS}$ = Low. Open drain output.   |
| 2       | Data Latch        | DL                               | MPX addresses are latched at the falling edge of DL input.  |
| 3       | Serial Input      | SI                               | Pin to accept MPX address data. Data read at the rising edge of $\overline{SCK}$ input.   |
| 4       | Serial Clock      | $\overline{SCK}$                 | $\overline{SCK}$ controls the shift operation of I/O interface 8-bit shift register. Input.   |
| 5       | Serial Output     | SO                               | Conversion data in shift register are output at the falling edge of $\overline{SCK}$ . High impedance when $\overline{CS}$ = High. Open drain output. |
| 6       | Chip Select       | $\overline{CS}$                  | $\overline{CS}$ = High: A/D conversion mode $\overline{CS}$ = Low: Interface mode. Input  |
| 7       | Clock             | CL <sub>0</sub>                  | Pin for clock oscillation.  |
| 8       | Clock             | CL <sub>1</sub>                  | Pin for clock oscillation.  |
| 9       | Digital Ground    | VSS                              | Ground terminal. Tie to GND with analog GND externally.   |
| 10 - 13 | Analog Inputs     | A <sub>0</sub> to A <sub>3</sub> | Analog input terminals.   |
| 14      | Analog GND        | GND                              | Ground terminal for analog inputs and references.   |
| 15      | Reference Input   | VREF                             | Pin to set full scale voltage. VREF to +2.5 V.  |
| 16      | Power Supply      | VDD                              | VDD (+5 V)  |

**ABSOLUTE MAXIMUM RATINGS (T<sub>a</sub> = 25 °C)**

|                         |                  |                              |    |
|-------------------------|------------------|------------------------------|----|
| Supply Voltage          | V <sub>DD</sub>  | -0.3 to +7.0                 | V  |
| Power Dissipation       | P <sub>T</sub>   | 200                          | mW |
| Analog Input Voltage    | V <sub>IA</sub>  | -0.3 to V <sub>DD</sub> +0.3 | V  |
| Reference Voltage       | V <sub>REF</sub> | -0.3 to V <sub>DD</sub> +0.3 | V  |
| Digital Input Voltage   | V <sub>ID</sub>  | -0.3 to +12                  | V  |
| Maximum Pull-up Voltage | V <sub>DD2</sub> | +12                          | V  |
| Operating Temperature   | T <sub>opt</sub> | 0 to +70                     | °C |
| Storage Temperature     | T <sub>stg</sub> | -65 to +125                  | °C |

**DC CHARACTERISTICS**

(T<sub>a</sub> = +25 °C ± 2 °C; f<sub>CK</sub> = 400 kHz, V<sub>DD</sub> = ±5 V, ±0.25 V, V<sub>REF</sub> = 2.500 V, Note 1)

| PARAMETER                                | SYMBOL            | LIMITS |      |                  | UNIT   | TEST CONDITION                                  |
|--|-------------------|--------|------|------------------|--------|---|
|  |                   | MIN.   | TYP. | MAX.             |        |   |
| Resolution                               |                   |        |      | 8                | Bit    |   |
| Nonlinearity                             | NL                |        |      | 0.8              | %FSR   |   |
| Full-Scale Error                         |                   |        | 1    | 2                | LSB    |   |
| Full-Scale Error Temperature Coefficient |                   |        | 30   |                  | ppm/°C |   |
| Zero Error                               |                   |        |      | 2                | LSB    |   |
| Zero Error Temperature Coefficient       |                   |        | 30   |                  | ppm/°C |   |
| Total Unadjusted Error 1                 | TUE1              |        |      | 2                | LSB    | Note 4  |
| Total Unadjusted Error 2                 | TUE2              |        |      | 2                | LSB    | Note 5  |
| Analog Input Voltage                     | V <sub>IA</sub>   | 0      |      | V <sub>REF</sub> | V      | Note 1  |
| Analog Input Resistance                  | R <sub>I</sub>    |        | 1000 |                  | MΩ     | V <sub>I</sub> = 0 to V <sub>DD</sub>           |
| Conversion Time                          | T <sub>CONV</sub> |        | 140  |                  | μs     | Note 2  |
| Clock Frequency Range                    | f <sub>CK</sub>   | 0.01   | 0.4  | 0.5              | MHz    |   |
| Clock Frequency Distribution             | Δf <sub>CK</sub>  |        | ±5   | ±20              | %      | R = 27 kΩ, C = 47 pF, f <sub>CK</sub> ≈ 400 kHz |
| Serial Clock Frequency                   | f <sub>SCK</sub>  |        | 0.5  |                  | MHz    | Note 3  |
| High Level Voltage                       | V <sub>IH</sub>   | 3.6    |      |                  | V      |   |
| Low Level Voltage                        | V <sub>IL</sub>   |        |      | 1.4              | V      |   |
| Digital Input Leakage Current            | I <sub>ID</sub>   |        | 1.0  | 10               | μA     | V <sub>I</sub> = V <sub>SS</sub> to +10 V       |
| Low Level Output Voltage                 | V <sub>OL</sub>   |        |      | 0.4              | V      | I <sub>DL</sub> = 1.7 mA                        |
| Output Leakage Current                   | I <sub>LEAK</sub> |        | 1.0  | 10               | μA     | V <sub>O</sub> = +10 V                          |
| Power Dissipation                        | P <sub>d</sub>    |        | 5    | 15               | mW     |   |

- Notes:**
1. All digital outputs are put at a high level when V<sub>I</sub> > V<sub>REF</sub>.
  2. A/D conversion is started with  $\overline{CS}$  going high; at the final step of the first A/D conversion,  $\overline{EOC}$  is low. The conversion time is: t<sub>CONV</sub> = 56/f<sub>CK</sub>
  3. For f<sub>SCK</sub> < 500 kHz, the load capacitor (stray capacitance included) and the pull-up resistor, which are connected to serial output, are required to be not more than 30 pF and 3 kΩ respectively.
  4. V<sub>DD</sub> = 5.00 V, V<sub>REF</sub> = 2.5 ± 0.25 V
  5. V<sub>DD</sub> = 4.5 to 5.5 V, V<sub>REF</sub> = 2.500 V

OPERATING CHARACTERISTICS

IDEAL INPUT/OUTPUT TRANSFER CHARACTERISTICS

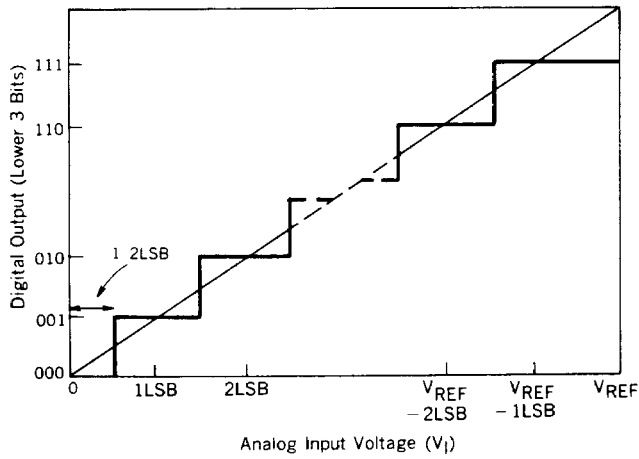

TOTAL UNADJUSTED ERROR

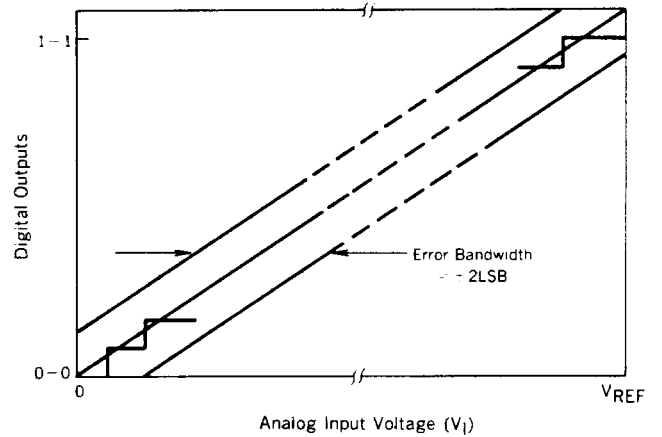

LINEARITY ERROR

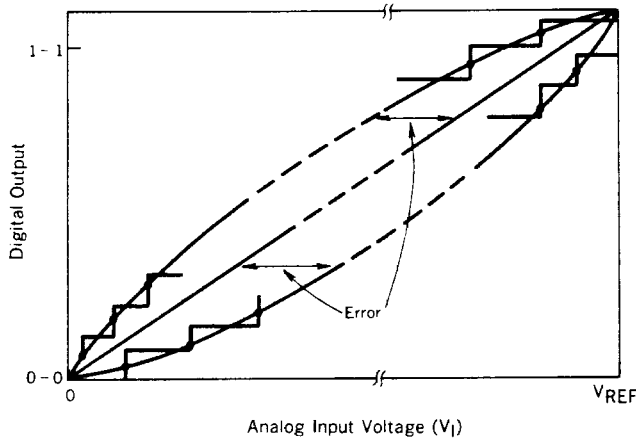

FULL SCALE ERROR

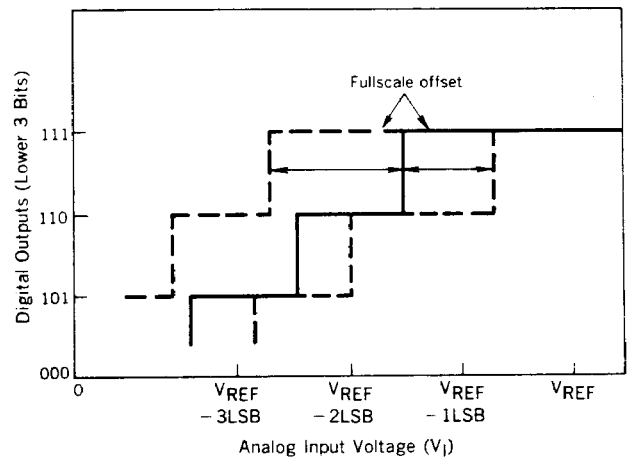

ZERO SCALE ERROR

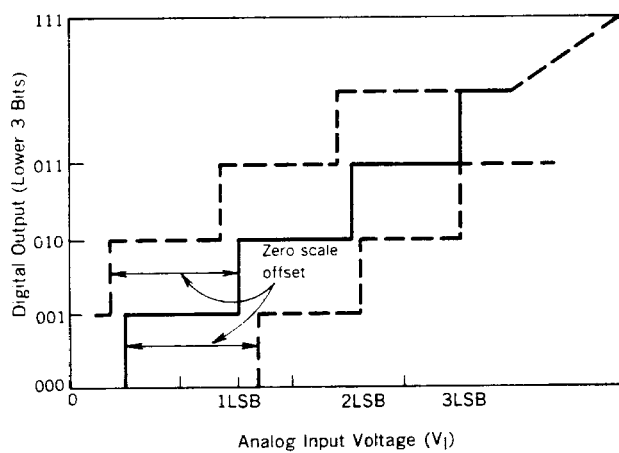

CLOCK FREQUENCY RANGE

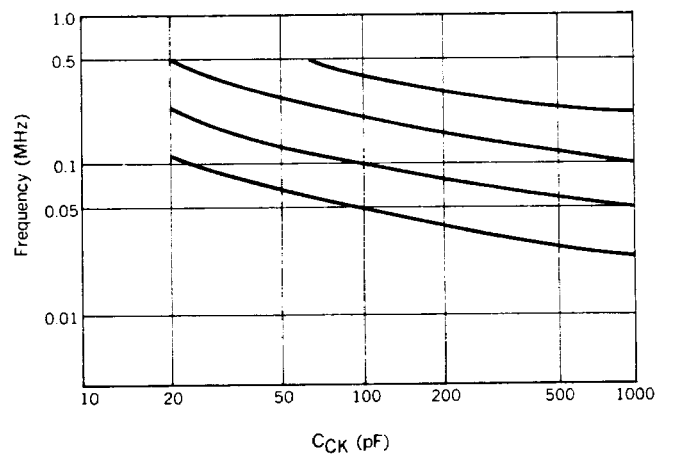

**OPERATING CHARACTERISTICS ( $T_a = 25^\circ\text{C}$ )**

T.U.E. vs.  $V_{REF}$

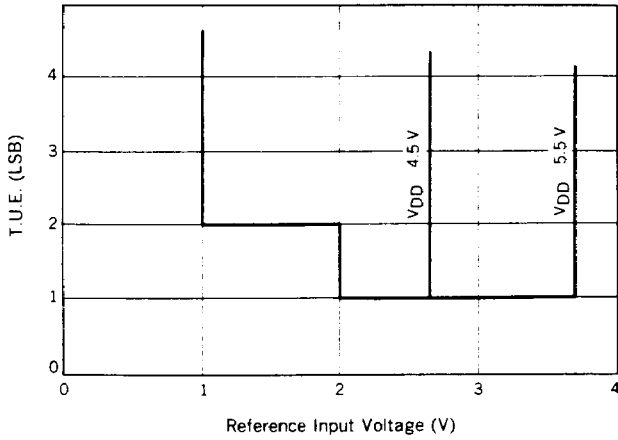

CLOCK OSCILLATION FREQUENCY vs. CURRENT CHARACTERISTICS

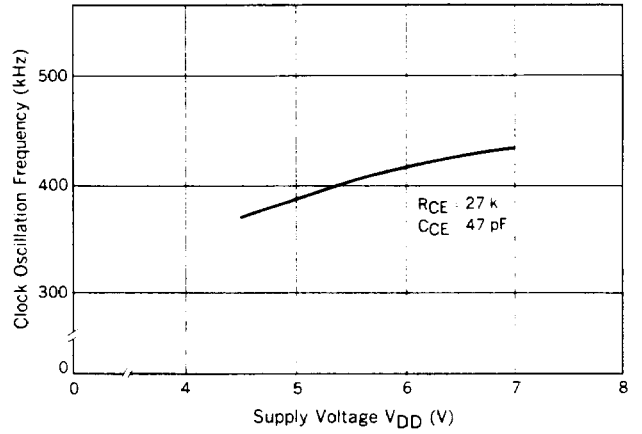

OUTPUT SINK CURRENT vs. SATURATION VOLTAGE CHARACTERISTICS

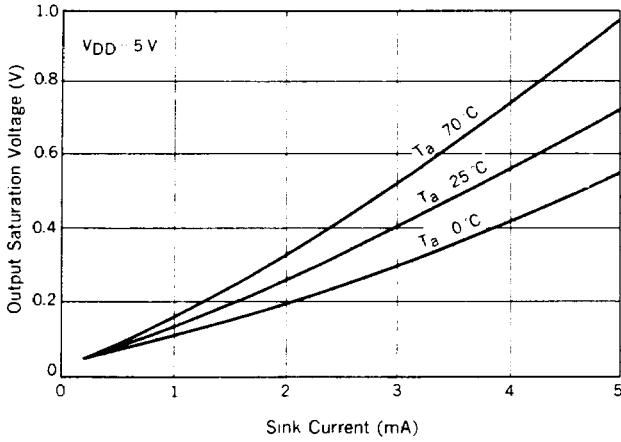

SUPPLY VOLTAGE vs. CURRENT CHARACTERISTICS

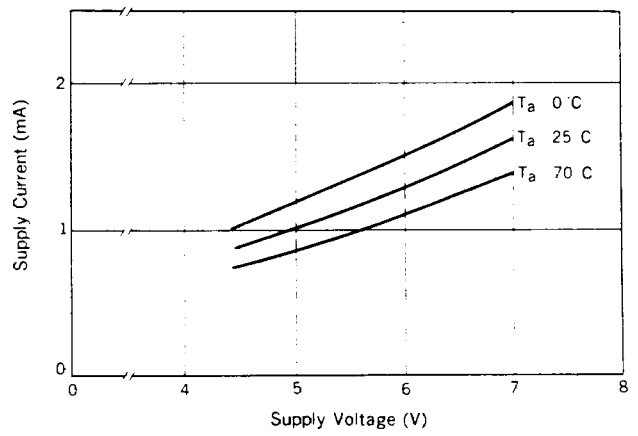

AC CHARACTERISTICS

( $T_a = +25\text{ }^\circ\text{C} \pm 2\text{ }^\circ\text{C}$ ;  $f_{CK} = 400\text{ kHz}$ ,  $V_{DD} = \pm 5\text{ V}$ , Note 1)

| PARAMETER                           | SYMBOL     | LIMITS |      |      | UNIT          | TEST CONDITION   |
|-------------------------------------|------------|--------|------|------|---------------|--|
|                                     |            | MIN.   | TYP. | MAX. |               |  |
| EOC Hold Time                       | $t_{HECS}$ | 0      |      |      | $\mu\text{s}$ | $\overline{\text{EOC}}$ to $\overline{\text{CS}}$                                      |
| CS Setup Time                       | $t_{SCSK}$ | 12.5   |      |      | $\mu\text{s}$ | $\overline{\text{CS}}$ to $\overline{\text{SCK}}$ Note 1                               |
| Address Data Setup Time             | $t_{SIK}$  | 150    |      |      | ns            |  |
| Address Data Hold Time              | $t_{HKI}$  | 100    |      |      | ns            |  |
| High Level Serial Clock Pulse Width | $t_{WHK}$  | 400    |      |      | ns            |  |
| Low Level Serial Clock Pulse Width  | $t_{WLK}$  | 400    |      |      | ns            |  |
| Data Latch Hold Time                | $t_{HKDL}$ | 200    |      |      | ns            | $\overline{\text{SCK}}$ to DL  |
| Data Latch Pulse Width              | $t_{WHDL}$ | 200    |      |      | ns            |  |
| Serial Data Delay Time              | $t_{DKO}$  |        |      | 500  | ns            | $\overline{\text{SCK}}$ to SO, $R_L = 3\text{ k}\Omega$ (Note 2), $C_L = 30\text{ pF}$ |
| Delay Time to Floating SO           | $t_{FCSO}$ |        |      | 250  | ns            | $\overline{\text{CS}}$ to High Impedance SO  |
| $\overline{\text{CS}}$ Hold Time    | $t_{HKCS}$ | 200    |      |      | ns            |  |

- Notes: 1. When  $\overline{\text{CS}}$  is high, the μPD7001 performs A/D conversion and does not accept any external digital signal. It remains at the previous state continuously. When  $\overline{\text{CS}}$  is low, the data is exchanged with the external digital circuits. However, 5 internal clock pulses are needed before digital data is output. The rating corresponds to the 5 clock signal pulses:  $t_{SCSK}(\text{min}) = 5/f_{CK}$
2. The serial data delay time depends on load capacitance and pull-up resistance:  $t_{DKO} \uparrow = 2.3 \times R_L \times C_L + 100\text{ ns}$ .

TIMING CHART

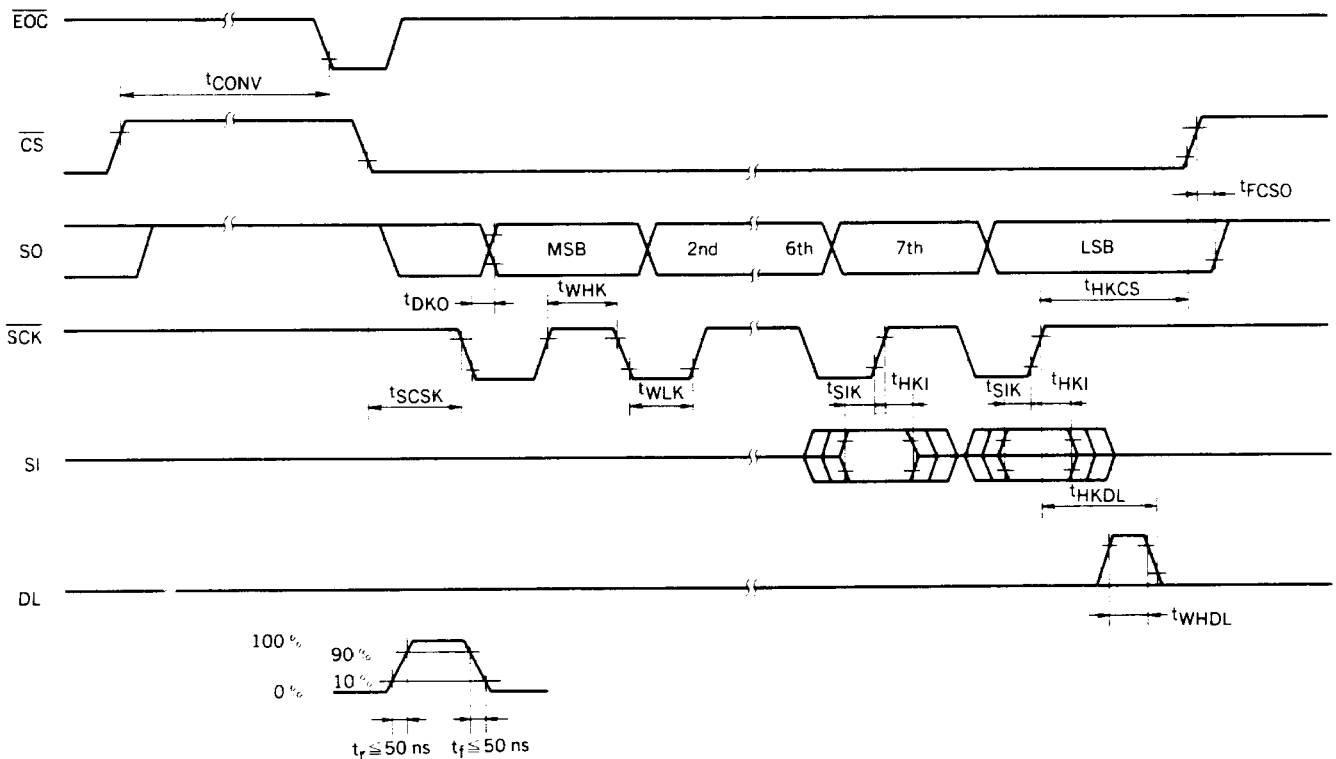

**OPERATIONS OF INTERNAL CIRCUIT BLOCKS**

**Sequence Controller**

When  $\overline{CS}$  is high, the sequence controller controls the internal A/D conversion sequence of the μPD7001. One A/D conversion takes 56 internal clock pulses to complete. As the final step, the conversion data is transferred to the shift register, and  $\overline{EOC}$  goes low. After this A/D conversion sequence is completed, the sequence controller is initialized to execute the next conversion. Thus, conversion data in the shift register is refreshed every 56 clock pulses.

**Shift Register**

A 9-bit shift register is incorporated in the μPD7001 for serial data exchange with peripheral devices. The serial input, output, and clock terminal of the shift register are strobed by the internal chip selects signal and are connected to SI, SO and  $\overline{SCK}$  pins respectively. A low level of  $\overline{CS}$  enables the interface with external peripheral devices. The shift register outputs data at the falling edge of  $\overline{SCK}$  and accepts data at its rising edge. In addition, for analog multiplexer address setting, the two input bits of the shift register are connected to the address decoder, and the address data is latched at the falling edge of DL.

**Analog Multiplexer**

One analog input signal from  $A_0-A_3$  is selected through the addressed multiplexer channel, and this input signal is transferred to the input of the A/D converter.

**A/D Converter**

The A/D converter section contains the successive approximation register, the 8-bit D/A converter, comparator and buffer amplifier. Voltage at the  $V_{REF}$  pin is used as a reference for the A/D conversion.

A/D conversion is executed automatically by the internal sequence controller. Because the μPD7001 uses the successive approximation technique, change in analog input voltage during the conversion causes a conversion error. Therefore, a low pass filter, and sample and hold circuit should be connected at the input to stabilize the conversion.

1. Data held in the internal sequence controller and address latch just after power-on is random. Therefore, an MPX address setting and a sequence controller resetting are required before a first conversion data reading.
2. When using long wires to connect external components and μPD7001 terminals, noise induction and some interference must be expected and taken into account.
3. The μPD7001 uses the successive approximation technique for A/D conversion; therefore, a sample and hold circuit is required when a fast varying analog input signal is applied. In addition, a C-R filter as shown below should be used, in order to minimize noise in a DC analog input signal.

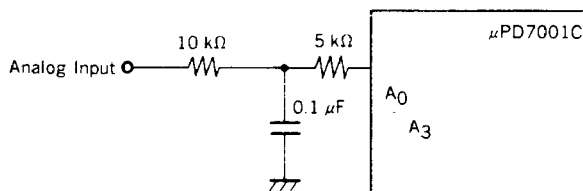

EXAMPLE OF THE APPLICATION CIRCUIT

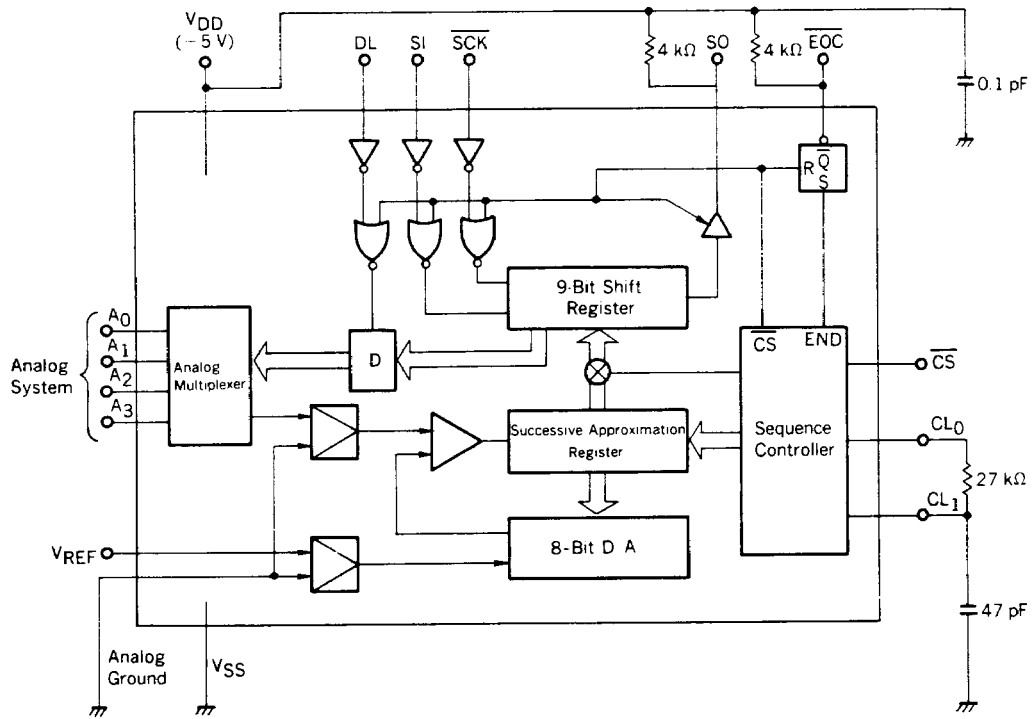

TIMING CHART

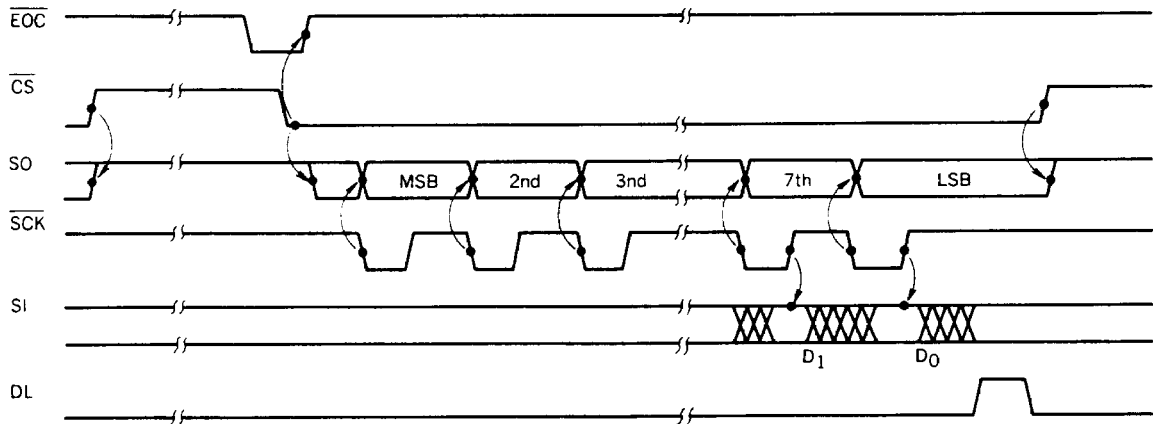

Multiplexer Channel Selection

| Analog Input Address | D0   | D1   |
|----------------------|------|------|
| A <sub>0</sub>       | Low  | Low  |
| A <sub>1</sub>       | High | Low  |
| A <sub>2</sub>       | Low  | High |
| A <sub>3</sub>       | High | High |



APPLICATION EXAMPLE: REDUCING DIGITAL I/O TERMINALS

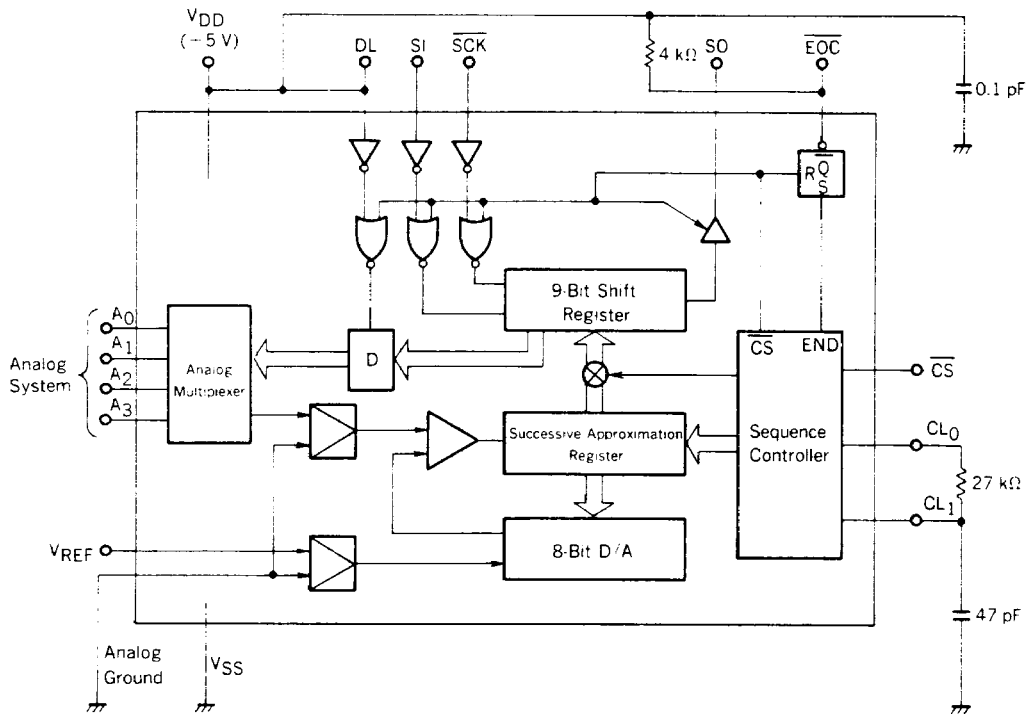

TIMING CHART

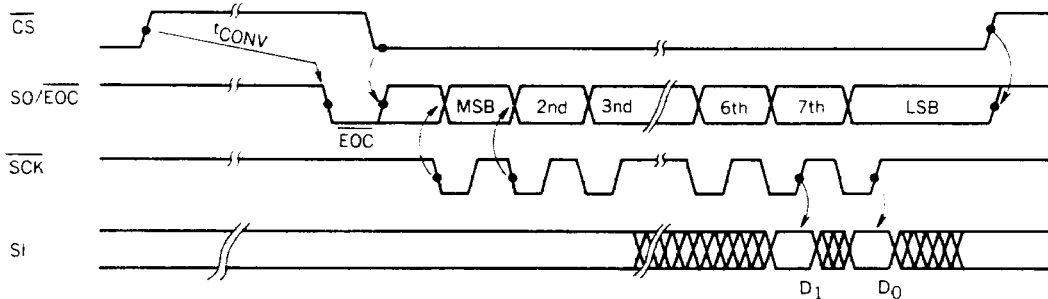

In this application, an MPX address write is required in every Date Read.

A wired OR connection is feasible, because  $\overline{EOC}$  and  $\overline{SO}$  are both open drain output and the signal output timing of  $\overline{EOC}$  is different from that of  $\overline{SO}$ .

The  $\overline{DL}$  signal is strobed by  $\overline{CS}$  in the chip. Therefore, by connecting  $\overline{DL}$  to  $V_{DD}$ , MPX Address Data is latched at the rising edge of  $\overline{CS}$ .

16PIN PLASTIC DIP (300 mil)

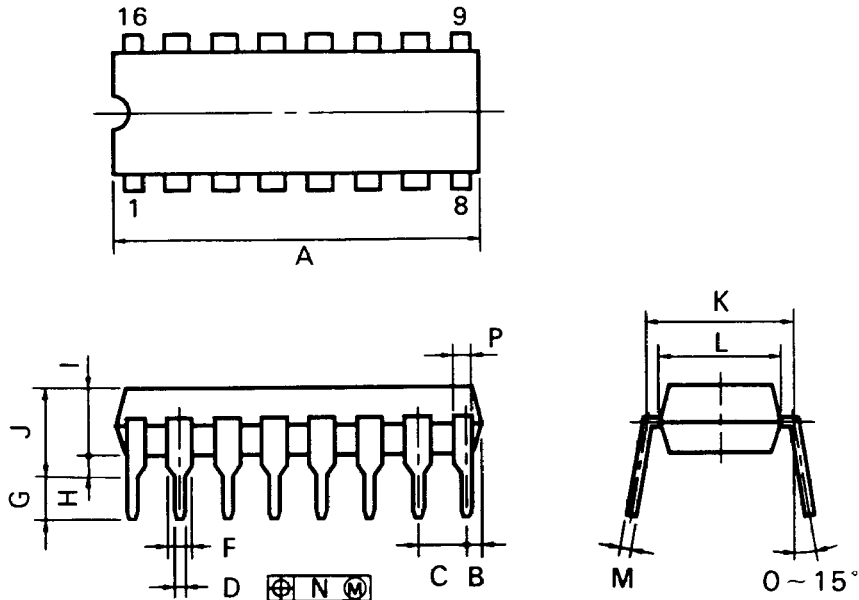

P16C-100-300A,C

**NOTES**

- 1) Each lead centerline is located within 0.25 mm (0.01 inch) of its true position (T.P.) at maximum material condition.
- 2) Item "K" to center of leads when formed parallel.

| ITEM | MILLIMETERS                            | INCHES                                    |
|------|--|---|
| A    | 20.32 MAX.                             | 0.800 MAX.                                |
| B    | 1.27 MAX.                              | 0.050 MAX.                                |
| C    | 2.54 (T.P.)                            | 0.100 (T.P.)                              |
| D    | 0.50 <sup>+0.10</sup>                  | 0.020 <sup>+0.004</sup> <sub>-0.005</sub> |
| F    | 1.2 MIN.                               | 0.047 MIN.                                |
| G    | 3.5 <sup>±0.3</sup>                    | 0.138 <sup>±0.012</sup>                   |
| H    | 0.51 MIN.                              | 0.020 MIN.                                |
| I    | 4.31 MAX.                              | 0.170 MAX.                                |
| J    | 5.08 MAX.                              | 0.200 MAX.                                |
| K    | 7.62 (T.P.)                            | 0.300 (T.P.)                              |
| L    | 6.4                                    | 0.252                                     |
| M    | 0.25 <sup>+0.10</sup> <sub>-0.05</sub> | 0.010 <sup>+0.004</sup> <sub>-0.005</sub> |
| N    | 0.25                                   | 0.01                                      |
| P    | 1.0 MIN.                               | 0.039 MIN.                                |