



UNISONIC TECHNOLOGIES CO., LTD

UPS602

LINEAR INTEGRATED CIRCUIT

HIGH PERFORMANCE CURRENT MODE POWER SWITCH

DESCRIPTION

The UTC UPS602 is designed to provide several special enhancements to satisfy the needs: Power-Saving mode for low standby power, Over Current Protection (OCP), Over Voltage Protection (OVP), Over Load Protection (OLP), UVLO, Over Temperature Protection (OTP) etc protection features. IC will be shutdown when either protection arise and can auto-restart.

FEATURES

- * Low startup current 20uA typ
- * Fixed switching frequency(Norm is 70kHz)
- * Max duty cycle 70%
- * Power-saving mode for low power
- * Over temperature protection
- * Overload protection
- * Over voltage protection
- * Leading edge blanking
- * Soft start

ORDERING INFORMATION

Order Number		Package	Packing
Normal	Lead Free Plating		
UPS602-D08-T	UPS602L-D08-T	DIP-8	Tube

<p>UPS602L-D08-T</p> <p>(1)Packing Type (2)Package Type (3)Lead Plating</p>	<p>(1) T: Tube (2) D08: DIP-8 (3) L: Lead Free Plating, Blank: Pb/Sn</p>
---	--

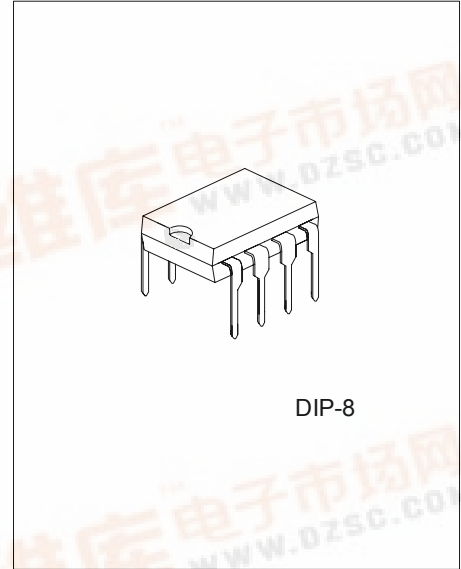

DIP-8

*Pb-free plating product number: UPS602L



■ PIN CONFIGURATION

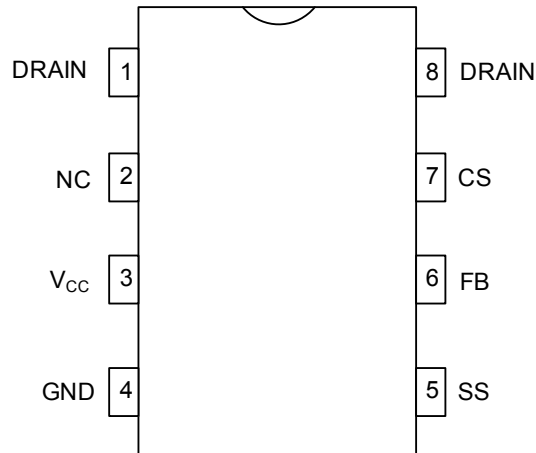

■ PIN DESCRIPTION

PIN	SYMBOL	FUNCTION
1	DRAIN	Power MOSFET drain
2	NC	
3	V _{CC}	Supply voltage
4	GND	Ground
5	SS	Soft-start
6	FB	Feedback
7	CS	Controller current sense input
8	DRAIN	Power MOSFET drain

■ BLOCK DIAGRAM

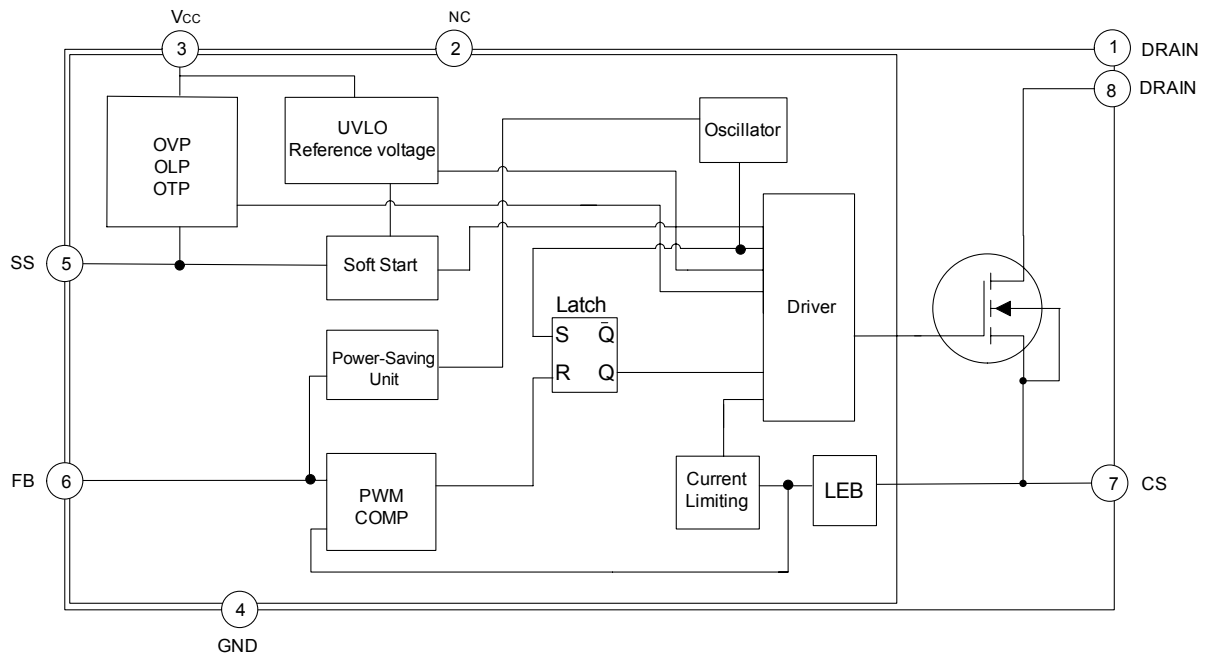

Explain: OLP(Over Load Protection)
 OVP(Over Voltage Protection)
 OTP(Over Temperature Protection)
 UVLO(Under Voltage Latch-Out)
 LEB(Led Edge Blanking)
 SS(Soft Start)

■ ABSOLUTE MAXIMUM RATINGS (Ta = 25°C, V_{CC}=15V, R_T=75kΩ, unless otherwise specified)

PARAMETER	SYMBOL	RATINGS	UNIT
Supply Voltage	V _{CC}	26	V
Input Voltage to FB Pin	V _{FB}	-0.3 ~ 6.2	V
Input Voltage to CS Pin	V _{CS}	-0.3 ~ 2.8	V
Input Voltage to RT Pin	V _{RT}	-0.3 ~ 6.2	V
Junction Temperature	T _J	+150	°C
Operating Temperature	T _{OPR}	-40 ~ +125	°C
Storage Temperature	T _{STG}	-50 ~ +150	°C

Note Absolute maximum ratings are those values beyond which the device could be permanently damaged.

Absolute maximum ratings are stress ratings only and functional device operation is not implied.

■ OPERATING RANGE

PARAMETER	SYMBOL	RATINGS	UNIT
Supply Voltage	V _{CC}	8.6 ~ 22	V

■ ELECTRICAL CHARACTERISTICS (Ta = 25°C, V_{CC}=15V, R_T=75kΩ, unless otherwise specified)

PARAMETER	SYMBOL	TEST CONDITIONS	MIN	TYP	MAX	UNIT	
SUPPLY SECTION							
Start Up Current	I _{STR}	V _{CC} =13.5		22	45	μA	
Supply Current with switch	OFF	V _{SS} = 0, I _{FB} = 0		3.7	5.5	mA	
	ON	V _{SS} = 5V, I _{FB} = 0		4.0	6.0	mA	
UNDER-VOLTAGE LOCKOUT SECTION							
Start Threshold Voltage	V _{THD(ON)}		11.8	12.6	13.4	V	
Min. Operating Voltage	V _{CC(MIN)}		7.6	8.1	8.6	V	
Hysteresis	V _{CC(HY)}			4.5		V	
INTERNAL VOLTAGE REFERENCE							
Reference Voltage	V _{REF}	measured at pin V _{FB}	6.1	6.3	6.5	V	
CONTROL SECTION							
Switch Frequency	Normal	F _(SW)	V _{FB} = 4V	61	68	75	kHz
	Power-Saving		V _{FB} = 1V	18	20	23	kHz
Duty Cycle	MAX	D _{MAX}		65	70	75	%
	MIN	D _{MIN}	V _{FB} < 0.5V	0			%
V _{FB} Operating Level	MIN	V _{MIN}		0.5			V
	MAX	V _{MAX}				4.4	V
Feedback Resistor	R _{FB}		2.6	3.8	5.0	kΩ	
Soft-Start Time	T _{SS}	C _{SS} =0.05μF		6			ms
		C _{SS} =0.1μF		12			ms
		C _{SS} =1μF		120			ms
PROTECTION SECTION							
OVP threshold	V _(OVP)	V _{SS} < 3.5V, V _{FB} > 5V	15.2	16	16.8	V	
OLP threshold	V _{FB(OLP)}	V _{SS} > 5.4V	4.4	4.6	4.9	V	
OTP threshold	T _(THR)		120	135	150	°C	
OVP Disable threshold	V _{SS(DEACT)}	V _{FB} > 5V, V _{CC} > 17V	3.7	3.9	4.2	V	
OLP Enable threshold	V _{SS(ACT)}	V _{FB} > 5V	4.9	5.1	5.4	V	
Spike Blanking time	T _{SB}			6.8		μs	
CURRENT LIMITING SECTION							
LEB	t _{LEB}			220		ns	
POWER MOS-TRANSISTOR SECTION							
Drain-Source Breakdown Voltage	V _{DSS}		600			V	
Static Drain-Source On-State Resistance	R _{DS(ON)}				5	Ω	
Output Capacitance	C _O			56		pF	

■ ELECTRICAL CHARACTERISTICS(Cont.)

PARAMETER	SYMBOL	TEST CONDITIONS	MIN	TYP	MAX	UNIT
Rise Time	t_R			21		ns
Fall Time	t_F			24		ns
Turn-Off Delay Time	$t_{D(OFF)}$			30		ns
Drain-Source Diode Continuous Source Current	I_S				2	A

■ FUNCTIONAL DESCRIPTION

The internal reference voltages and bias circuit work at $V_{CC} > 12.6V$, and shutdown at $V_{CC} < 8.1V$.

(1) Soft-Start

When every IC power on, driver output duty cycle will be decided by voltage V_{SS} on soft-start capacitor and V_{CS} on current sense resistor at beginning. After V_{SS} reach 5.1V, the whole soft-start phase end, and driver duty cycle depend on V_{FB} and V_{CS} . The relation among V_{SS} , V_{FB} and V_{OUT} as followed FIG.3, here soft-start phase $T_{soft-start}$ should more than V_{OUT} start-up phase $T_{start-up}$, otherwise, IC will enter false OLP protection state. Because after the soft-start phase end, if V_{OUT} remain in lower voltage, V_{FB} more than 4.6V, then IC enter false OLP state.

Furthermore, soft-start phase should end before V_{CC} reach $V_{CC(MIN)}$ during V_{CC} power on. Otherwise, if soft-start phase remain not end before V_{CC} reach $V_{CC(MIN)}$ during V_{CC} power on, IC will enter auto-restart phase and not set up V_{OUT} .

Finally soft-start also set OVP active phase. OVP active phase between $V_{SS}=0$ and $V_{SS}=3.8V$, OVP will not be sensed after V_{SS} reach 3.8V. The Soft-start phase T_{SS} :

$$T_{SS} = \begin{cases} 6 \text{ ms} & (C_{SS}=0.05\mu F) \\ 12 \text{ ms} & (C_{SS}=0.1\mu F) \\ 120 \text{ ms} & (C_{SS}=1\mu F) \end{cases}$$

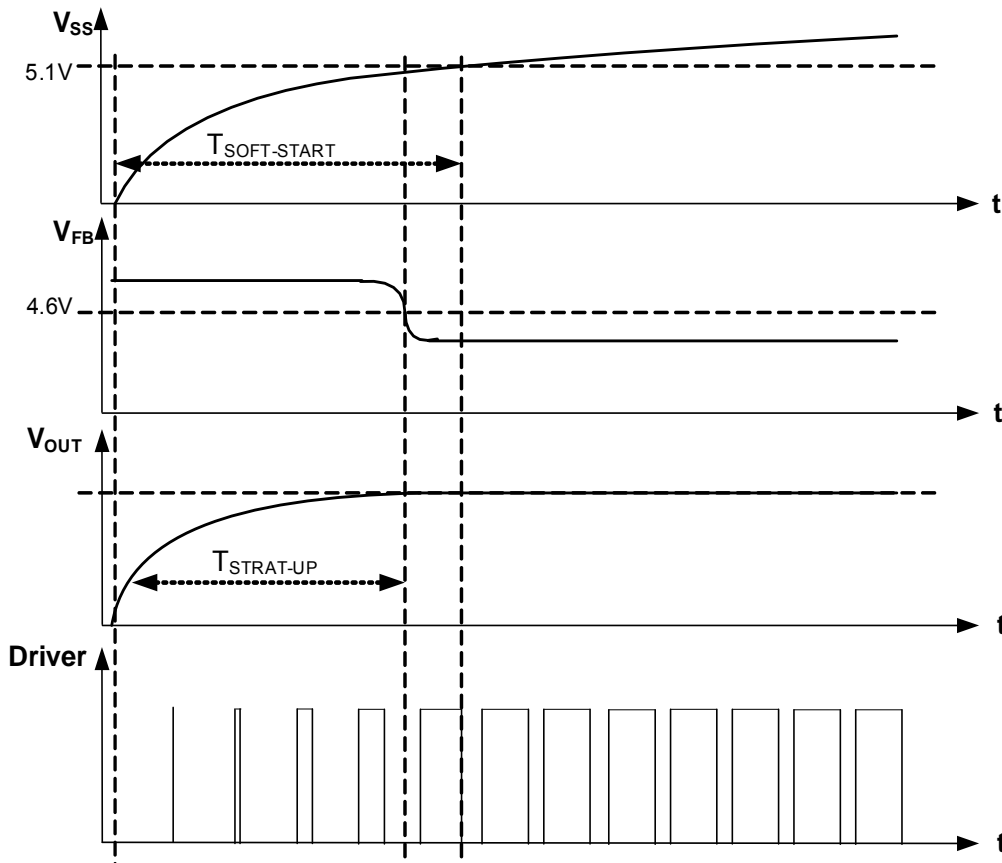

FIG.3 Soft-start phase

■ FUNCTIONAL DESCRIPTION(Cont.)

(2) Switch Frequency Set

The maximum switch frequency decided by an external resistor R_T connected between pin R_T and ground. Then the maximum switch frequency will depend on user requirement. The relation curve between f_{SW} and R_T as followed FIG.5 under the condition of $P_{OUT}/P_{OUTmax}=50\%$. The equation between f_{SW} and R_T as followed (1-2):

$$f_{SW} = -0.61 \cdot R_T + 115.7 \text{-----(1-2)}$$

After R_T connected, switch frequency is also modulated by output power P_{OUT} during IC operating. So lower switch frequency at lower load, which more and more improve IC's efficiency at light load. Switch frequency is decreased minimum at no load, then the UPS602 will operate at Power-Saving mode for Lower standby power. The relation curve between f_{SW} and P_{OUT}/P_{OUTmax} as followed FIG.4 under the condition of $R_T=75k\Omega$.

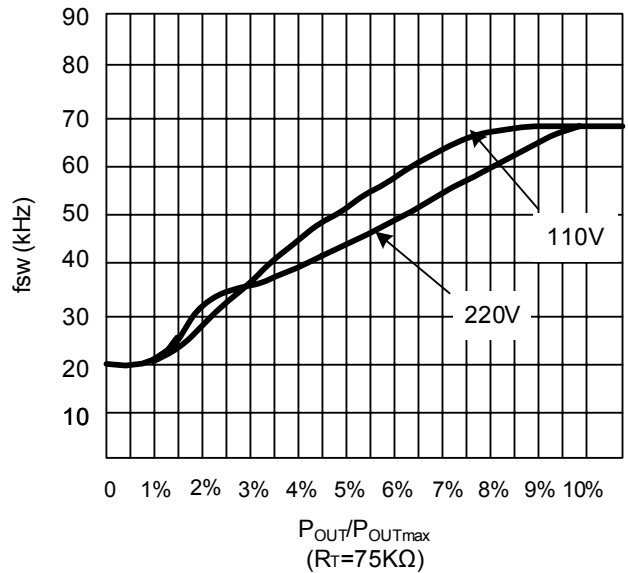

FIG.4 The relation curve between f_{SW} and relative output power P_{OUT}/P_{OUTmax}

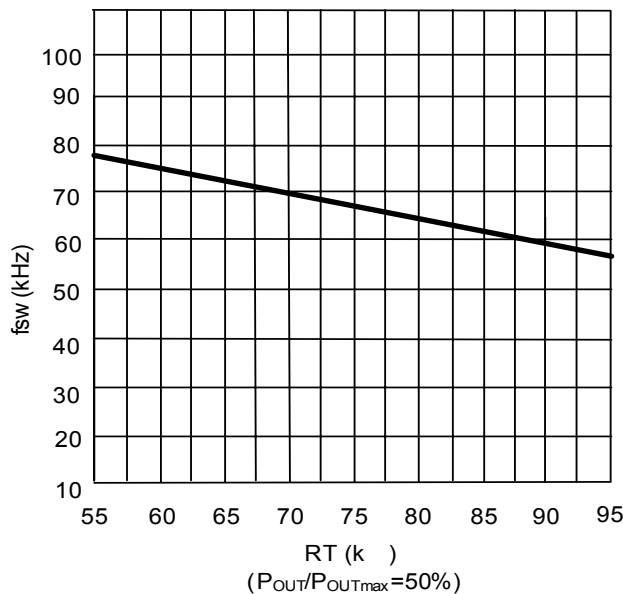

FIG.5 The relation curve between f_{SW} and R_T

FUNCTIONAL DESCRIPTION(Cont.)

(3) Protection section

UPS602 takes on more protection functions such as OLP, OVP and OTP etc. In case of those failure modes for continual 7.2 μ s (blanking time), the driver is shut down. At the same time, IC enters auto-restart, V_{CC} power on and driver is reset after V_{CC} power on again.

OLP

After soft-start phase end (V_{SS}>5.1V), IC will shutdown driver if over load state occurs (corresponding to V_{FB}>4.6V) for continual 7.2 μ s. OLP function will not inactive during soft-start phase. OLP case as followed FIG. 6. The test circuit as followed FIG.8 for UPS602.

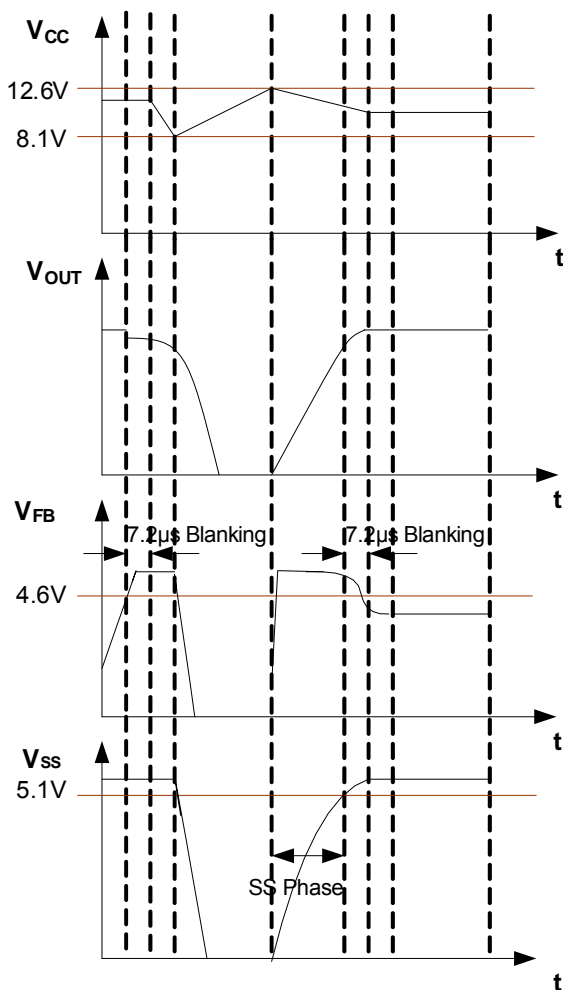

FIG.6 OLP case

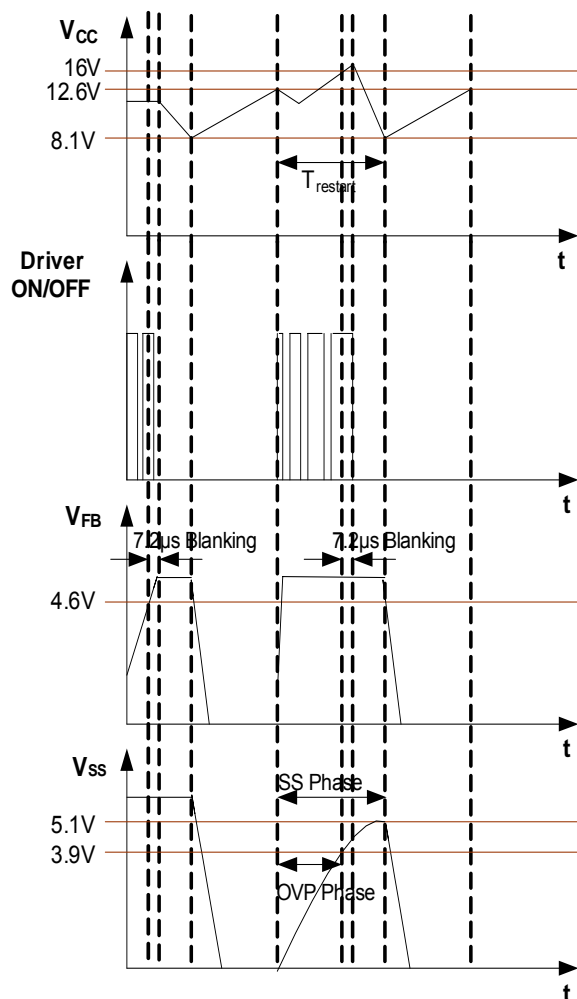

FIG.7 OVP case

OVP

Power supply V_{CC}'s OVP function are enabled only when V_{SS}<3.9 & V_{FB}>4.6V during soft-start phase. During above condition, driver will be shutdown if over voltage state occurs (V_{CC}>16V) for continual 7.2 μ s. OVP function will not inactive after soft-start phase. OLP case as followed FIG.7. The test circuit as followed FIG.9 for UPS602.

OTP

OTP will shut down driver when junction temperature T_J of internal circuits is more than threshold 135°C for continual 7.2 μ s.

■ FUNCTIONAL DESCRIPTION(Cont.)

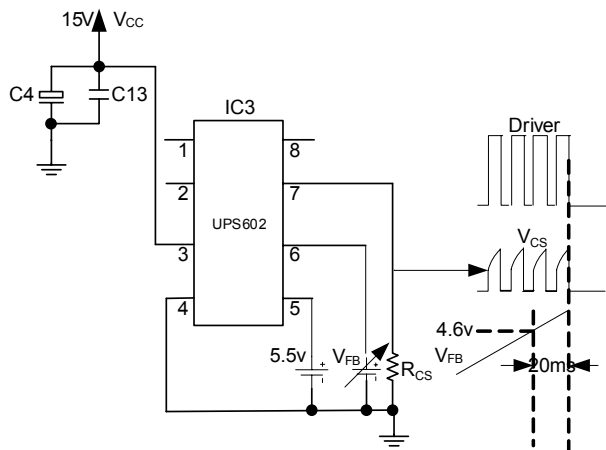

FIG.8 OLP test circuit

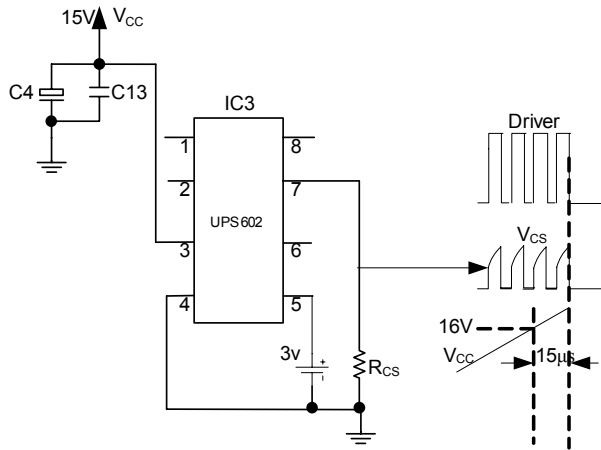

FIG.9 OVP test circuit

(4) Driver Output Section

Rise edge time of driver output is about 200ns for avoiding Low EMI.

(6) Inside power switch MOS transistor

For UPS602, it's inside power MOS transistor may load source current 2A. Specific power MOS transistor parameter is as "POWER MOS TRANSISTOR SECTION" in electrical characteristics table.

■ TYPICAL CHARACTERISTICS(Cont.)

Fig 1. Feedback Voltage During Loadjump From 10% Up To 100% Load ($V_{DCIN}=120V$)

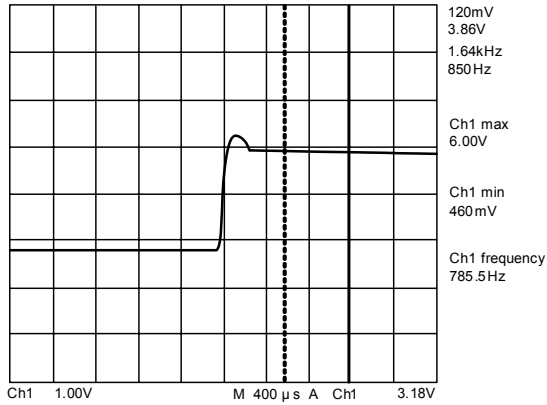

Fig 2. Feedback Voltage During Loadjump From 10% Up To 100% Load ($V_{DCIN}=350V$)

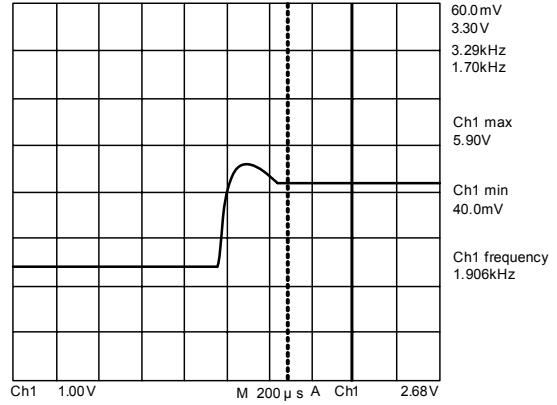

Fig 3. Startup With Full Load Condition At $V_{DCIN}=120V$, V_{C4} and V_{out}

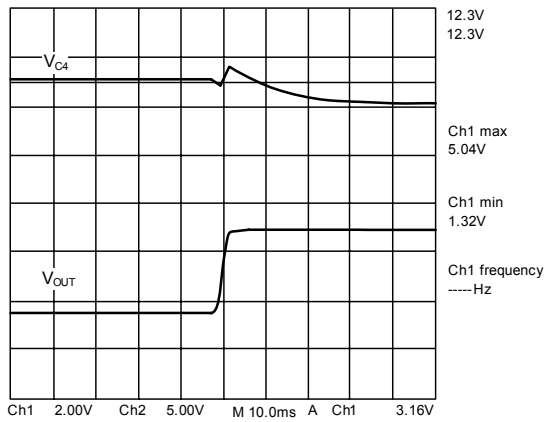

Fig 4. Startup With Full Load Condition At $V_{DCIN}=350V$, V_{C4} and V_{out}

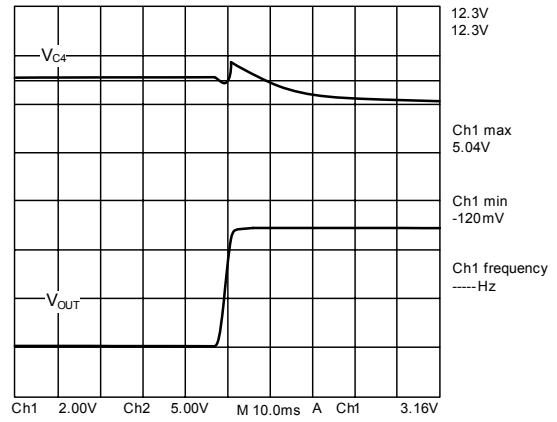

Fig 5. Startup Behavior At Nominal Load Condition $V_{DCIN}=120V$

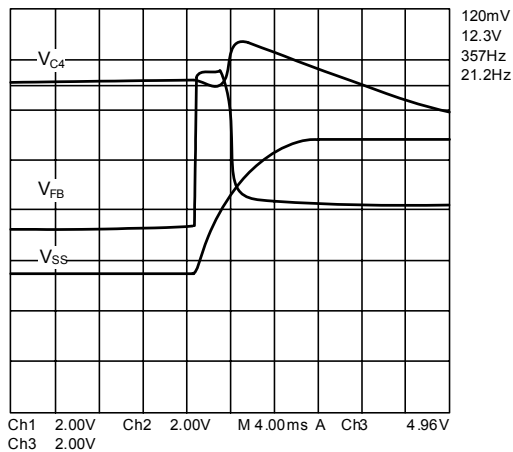
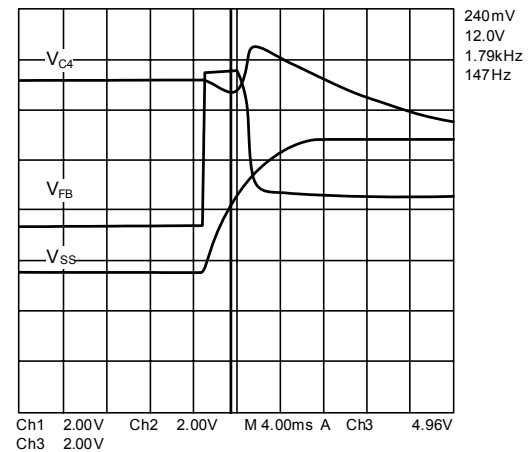

Fig 6. Startup Behavior At Nominal Load Condition $V_{DCIN}=350V$



■ TYPICAL CHARACTERISTICS(Cont.)

Fig 7. Frequency vs. Output Power

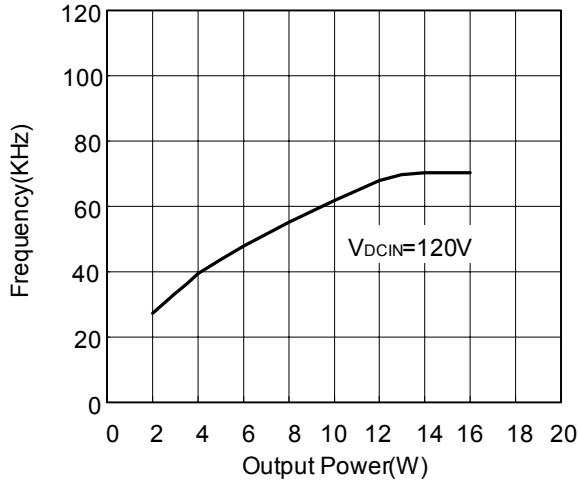
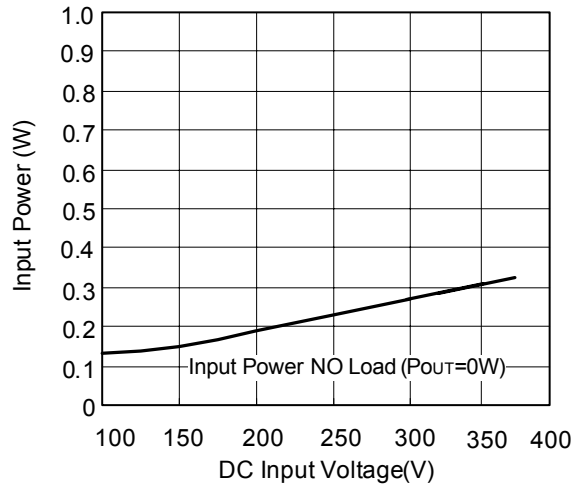

Fig 8. NO Load Input Power vs. Line Voltage (Normal Mode)



UTC assumes no responsibility for equipment failures that result from using products at values that exceed, even momentarily, rated values (such as maximum ratings, operating condition ranges, or other parameters) listed in products specifications of any and all UTC products described or contained herein. UTC products are not designed for use in life support appliances, devices or systems where malfunction of these products can be reasonably expected to result in personal injury. Reproduction in whole or in part is prohibited without the prior written consent of the copyright owner. The information presented in this document does not form part of any quotation or contract, is believed to be accurate and reliable and may be changed without notice.