

Table of Contents

1 Functional Diagram	1
2 General Description.....	1
3 Glossary of Terms	3
4 Absolute Maximum Ratings.....	3
5 Pin Definitions and Descriptions.....	3
6 General Electrical Specifications	4
7 Magnetic Specifications	4
8 Driver Output vs Magnetic Pole.....	4
9 Detailed General Description.....	5
10 Unique Features.....	5
11 Performance Graphs	6
11.1 $R_{DS(ON)}$ vs T_J	6
11.2 $R_{DS(ON)}$ vs V_{DD}	6
11.3 Magnetic parameters vs T_J	6
11.4 Magnetic parameters vs V_{DD}	6
11.5 I_{DD} vs T_J	6
11.6 I_{DD} vs V_{DD}	6
11.7 V_{OL} vs T_J	7
11.8 Power Dissipation vs. T_A	7
12 Application Information.....	7
12.1 Typical application with pull-up resistor.....	7
12.2 Configuration for reverse voltage / ground hot-switch protection and enhanced ESD module protection	7
13 Application Comments.....	7
14 Standard information regarding manufacturability of Melexis products with different soldering processes.....	8
15 ESD Precautions	8
16 Package Information.....	9
16.1 VK Package Information (4-pin TO92).....	9
16.2 DC Package Information (8-pin narrow SOIC).....	10
16.3 VA Package Information (4-pin TO92 flat).....	11
17 Disclaimer.....	12

3 Glossary of Terms

Two-coil fan	A fan with two-coil windings where current alternates from 1 coil to the other depending on the direction of the magnetic field.
MilliTesla (mT), Gauss	Units of magnetic flux density : 1mT = 10 Gauss
V _{DD}	Voltage on the coils common node.
I _{DD}	Current supplying the chip which flows through the coil connected to the switched off output driver.
Peak output current	The current flowing in the coil at start-up, only limited by the coil resistance R _{COIL} and the output driver resistance R _{DSON} .
Continuous output current	The current flowing in the coil when the fan is spinning normally.
Locked rotor	The state when the fan stopped spinning due to mechanical blockage.
FG	Frequency generator or tachometer output
RD	Rotation detection or alarm output
LFPM	Linear Feet Per Minute – Unit of airflow velocity

4 Absolute Maximum Ratings

Parameter	Symbol	Value	Units
Fan Supply Voltage	V _{DD}	30	V
Peak Output Current	I _{OUTp}	500	mA
Continuous Output Current	I _{OUTc}	250	mA
FG / RD Output Current	I _{FG (RD)}	20	mA
Operating Temperature Range	T _A	-40 to 85	°C
Junction Temperature	T _J	125	°C
Storage Temperature Range	T _S	-55 to 150	°C
Magnetic Flux Density	B	Unlimited	mT

Table 1: Absolute maximum ratings

Exceeding the absolute maximum ratings may cause permanent damage. Exposure to absolute-maximum-rated conditions for extended periods may affect device reliability.

5 Pin Definitions and Descriptions

Pin Name	Pin number (VK)	Pin number (DC)	Pin number (VA)	Function
FG (RD)	1	1	1	FG (RD) open drain output signal
OUT1	2	2	2	Open Drain Coil Driver 1
OUT2	3	4	4	Open Drain Coil Driver 2
GND	4	3	3	Ground pin
-	-	5, 6, 7, 8	-	Not Connected

Table 2: Pin definitions and descriptions US90A (US91A)

6 General Electrical Specifications

DC Operating Parameters $T_A = 25^\circ\text{C}$, $V_{DD} = 24\text{V}$ (unless otherwise specified)

Parameter	Symbol	Test Conditions	Min	Typ	Max	Units
Fan Supply Voltage	V_{DD}	Operating, $R_{COIL} = 50\Omega$	4.7 ⁽¹⁾		30	V
Supply Current	I_{DD}			2	4	mA
Output Saturation Voltage	$V_{DSON\ 1,2}$	$I_{OUT} = 150\text{mA}$		375		mV
Output Saturation Voltage	$V_{DSON\ 1,2}$	$I_{OUT} = 250\text{mA}$		625		mV
Output Clamp Voltage	$V_{OUT\ 1,2}$		60			V
FG / RD Output Low Voltage	V_{OL}	$I_{OL} = 10\text{mA}$		250	500	mV
FG / RD Output Clamp Voltage	V_{CLAMP}		28			V
FG / RD Output Leakage Current	I_{LEAK}	$V_{FG} (V_{RD}) = 18\text{V}$			10	μA
DC Thermal Resistance	R_{THja}	One-sided PCB, zero LFPM		150		$^\circ\text{C/Watt}$
VK Thermal Resistance	R_{THja}	One-sided PCB, zero LFPM		200		$^\circ\text{C/Watt}$
VA Thermal Resistance	R_{THja}	One-sided PCB, zero LFPM		170		$^\circ\text{C/Watt}$
Locked Rotor Period	T_{ON}			0.25		S
Locked Rotor Period	T_{OFF}			1.5		S
Output Switching Delay	T_{DELAY}	"Dead time" when both drivers are off		200		us

Table 3: General electrical specifications

Note 1: The minimal value of V_{DD} should be determined using the following equation: $V_{DD} = 4.5\text{V} + R_{COIL} * I_{DD}$

7 Magnetic Specifications

DC Operating Parameters $T_A = 25^\circ\text{C}$, $V_{DD} = 24\text{V}$ (unless otherwise specified)

Parameter	Symbol	Test Conditions	Min	Typ	Max	Units
Operate point	B_{OP}			3	6	mT
Release point	B_{RP}		-6	-3		mT
Hysteresis	B_{HYST}		2	6		mT

Table 4: Magnetic specifications

8 Driver Output vs Magnetic Pole

Parameter	Test Conditions	OUT1	OUT2
North pole	$B < B_{rp}$ – all packages	High	Low
South pole	$B > B_{op}$ - all packages	Low	High

Table 5: Driver output vs. magnetic pole

Note 3: The magnetic pole is applied facing the branded side of the package

9 Detailed General Description

The US90A/91A is a one-chip solution for driving two-coil brushless DC fans. Based on advanced Melexis CMOS process, the IC contains a Hall-effect sensor, dynamic offset correction and low side output drivers.

The output drivers OUT1 and OUT2 are fully protected against switching transients. So there is no need for an external zener diode to cut the high voltage spikes induced by the fan coils.

The US90A has an open-drain integrated tachometer FG output that follows the Hall signal. In the US91A, the open-drain rotation detection output RD is active low during normal spinning of the motor. It goes high when the flux switching frequency becomes too low, which means the motor is blocked.

10 Unique Features

The absence of a V_{DD} pin enables the two low side output drivers and FG/RD signal output to fit in a four-pin VK package. The lack of a V_{DD} pin decreases also the probability to damage the chip due to reverse voltage connection, using the coil resistance to limit the reverse current. In this condition, the total reverse current is twice the peak current value of the fan used.

The built-in locked-rotor protection will automatically shut off the coil current when the rotor is mechanically blocked, or the rotational speed drops below 60 RPM (4-pole rotor magnet). The fan will try to restart every 1.5 seconds until the obstruction is clear. The On / Off cycling reduces the average stall current to 1/7 normal; this is enough to prevent overheating or damage to most fans. Both the US90A and US91A have this feature.

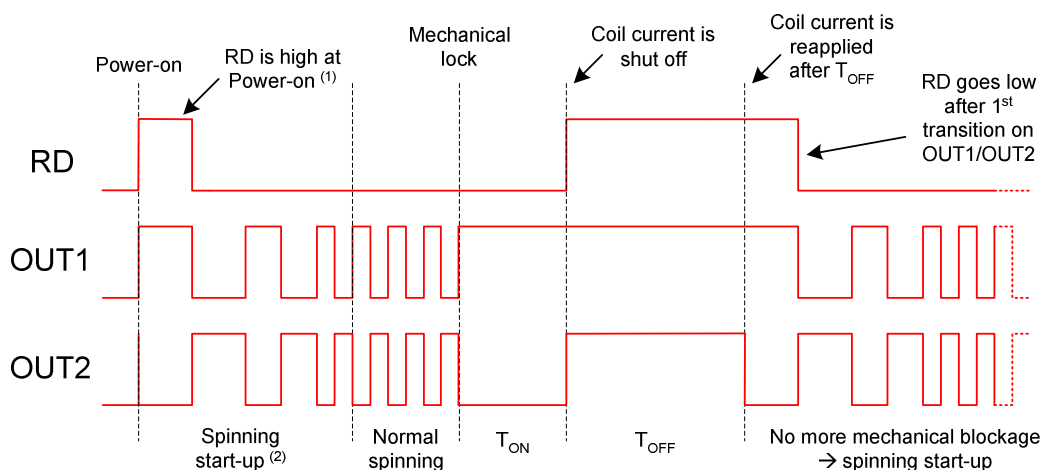

Note 1 : At Power-on, RD is high until the 1st transition on OUT1/OUT2.

Note 2 : The spinning start-up is the ramp between the zero speed and maximal speed. It depends on the motor characteristics.

Note 3 : This graph does not represent the EMF effect.

11 Performance Graphs

11.1 $R_{DS(on)}$ vs T_J

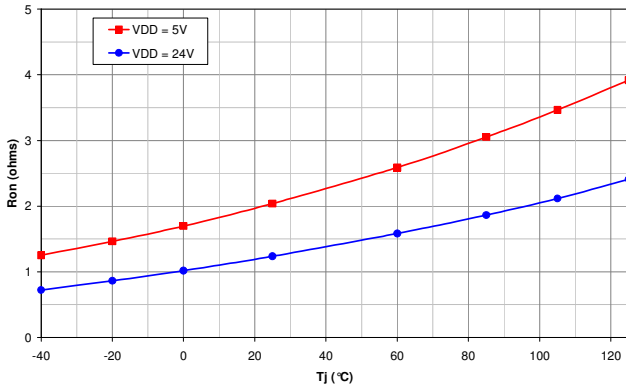

11.2 $R_{DS(on)}$ vs V_{DD}

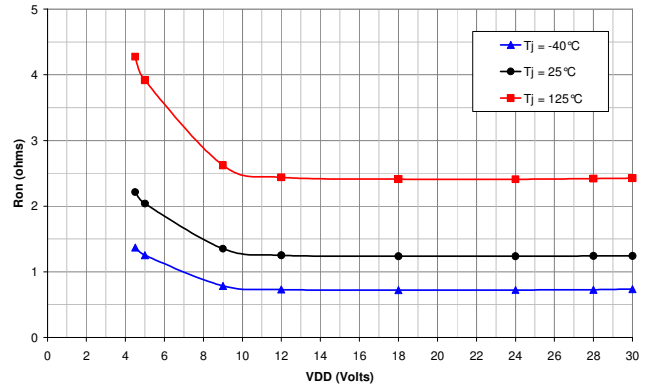

11.3 Magnetic parameters vs T_J

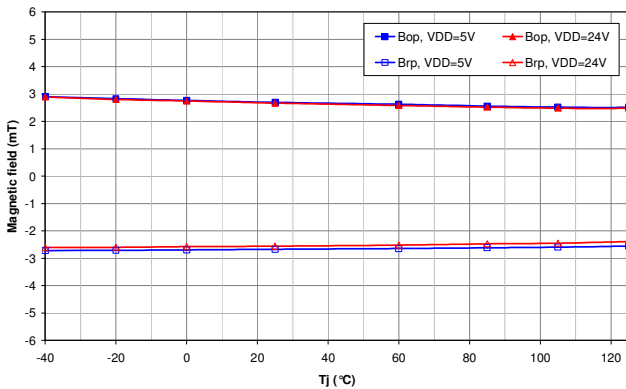

11.4 Magnetic parameters vs V_{DD}

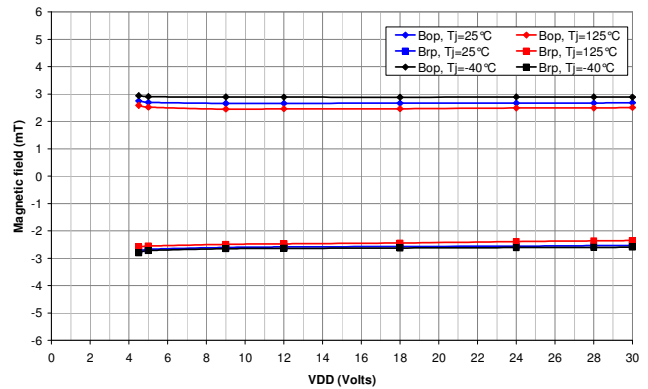

11.5 I_{DD} vs T_J

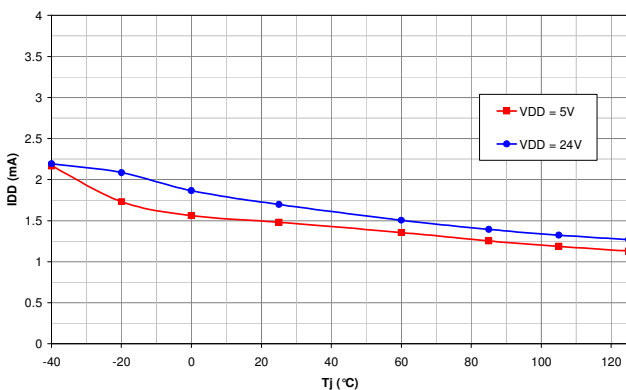

11.6 I_{DD} vs V_{DD}

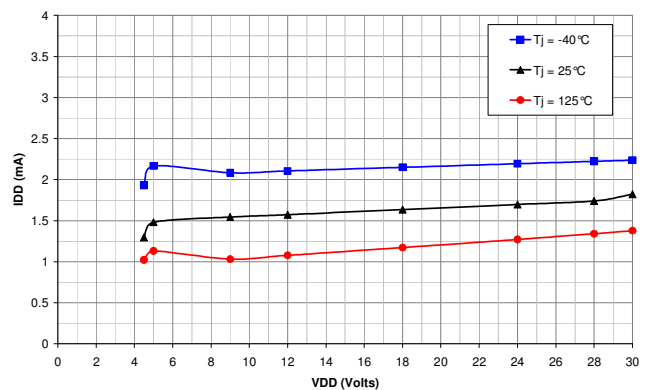

11.7 V_{OL} vs T_J

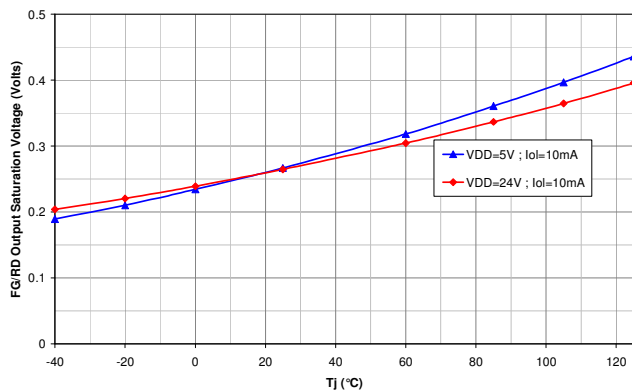

11.8 Power Dissipation vs. T_A

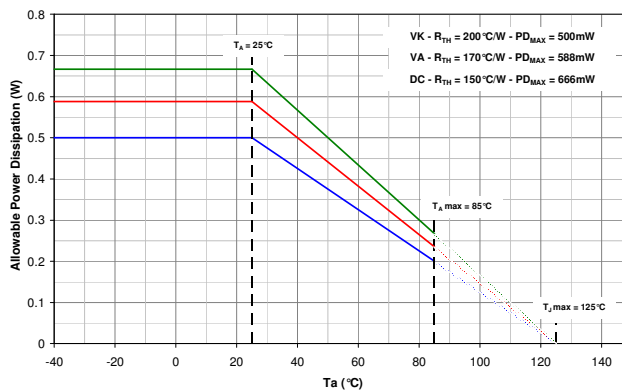

12 Application Information

12.1 Typical application with pull-up resistor

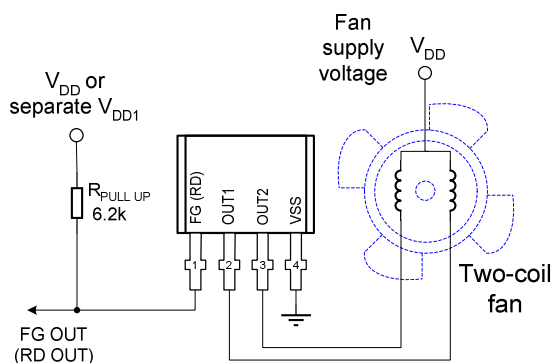

12.2 Configuration for reverse voltage / ground hot-switch protection and enhanced ESD module protection

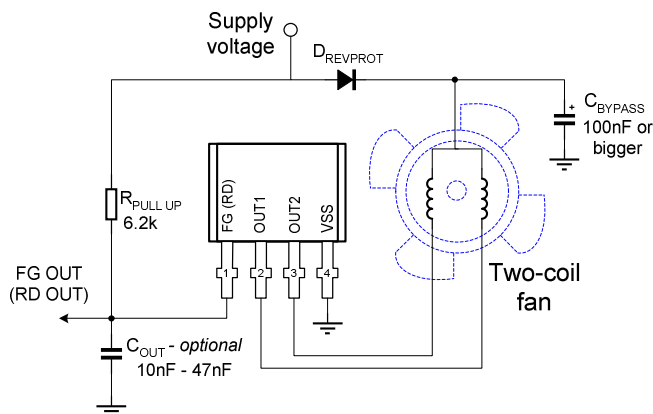

13 Application Comments

Figure 12.2 shows the application including several external protections.

The diode $D_{REVPROT}$ best protects the chip and fan coils for reverse voltage condition.

The capacitor C_{BYPASS} is recommended if the supply ground may be disconnected while running even though the positive supply point is still connected. This capacitor provides a path to ground for the remaining energy in the coil which has to be evacuated. Without it, the energy can flow from OUT1/OUT2 to the FG/RD driver, without any limitation and may cause EOS damage.

Its value has to be tuned depending on the coils characteristics. Bigger inductance requires bigger capacitor.

The no- V_{DD} design enables ESD protection at fan module level to be easily improved. The fan coils prevent and filter fast current stress on OUT1 and OUT2, resulting in better ESD protection. Adding the optional capacitor C_{OUT} enhances the ESD protection of the logic output. Hence, the fan module is able to withstand ESD stress at relatively high value without damage.

14 Standard information regarding manufacturability of Melexis products with different soldering processes

Our products are classified and qualified regarding soldering technology, solderability and moisture sensitivity level according to following test methods:

Reflow Soldering SMD's (Surface Mount Devices)

- IPC/JEDEC J-STD-020
Moisture/Reflow Sensitivity Classification for Nonhermetic Solid State Surface Mount Devices (classification reflow profiles according to table 5-2)
- EIA/JEDEC JESD22-A113
Preconditioning of Nonhermetic Surface Mount Devices Prior to Reliability Testing (reflow profiles according to table 2)
- Melexis Working Instruction 341901308

Wave Soldering SMD's (Surface Mount Devices) and THD's (Through Hole Devices)

- EN60749-20
Resistance of plastic- encapsulated SMD's to combined effect of moisture and soldering heat
- EIA/JEDEC JESD22-B106 and EN60749-15
Resistance to soldering temperature for through-hole mounted devices
- Melexis Working Instruction 341901309

Iron Soldering THD's (Through Hole Devices)

- EN60749-15
Resistance to soldering temperature for through-hole mounted devices
- Melexis Working Instruction 341901309

Solderability SMD's (Surface Mount Devices) and THD's (Through Hole Devices)

- EIA/JEDEC JESD22-B102 and EN60749-21
Solderability
- Melexis Working Instruction 3304312

For all soldering technologies deviating from above mentioned standard conditions (regarding peak temperature, temperature gradient, temperature profile etc) additional classification and qualification tests have to be agreed upon with Melexis.

The application of Wave Soldering for SMD's is allowed only after consulting Melexis regarding assurance of adhesive strength between device and board.

For more information on the lead free topic please see quality page at our website:
<http://www.melexis.com/quality.aspx>

15 ESD Precautions

Electronic semiconductor products are sensitive to Electro Static Discharge (ESD). Always observe Electro Static Discharge control procedures whenever handling semiconductor products.

16 Package Information

16.1 VK Package Information (4-pin TO92)

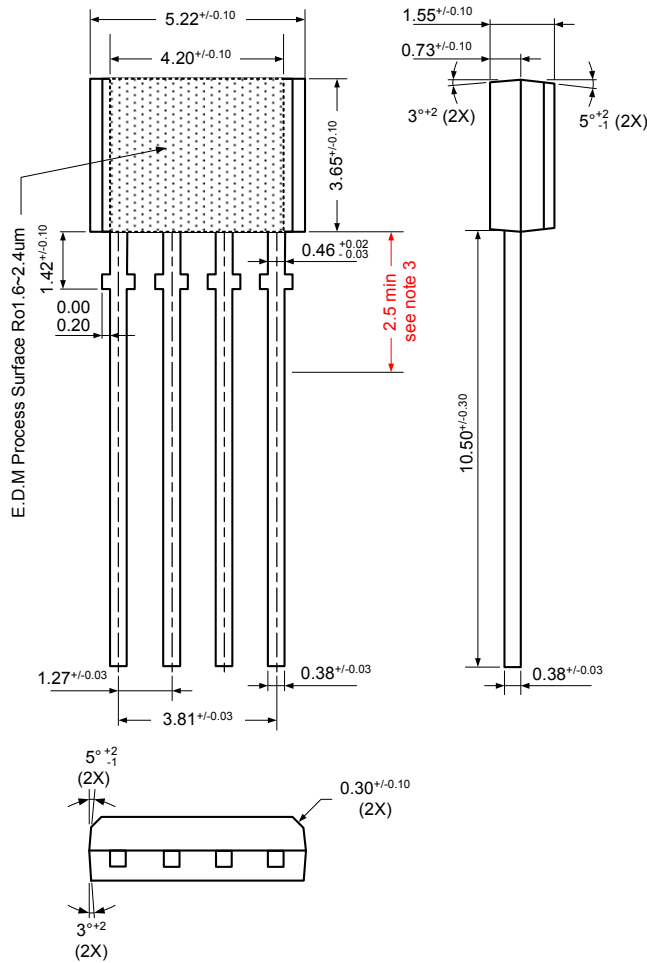

Notes:

1. All dimensions are in millimeters
2. Package dimension exclude molding flash. Mold flash shall not exceed 0.127mm.
3. To preserve reliability, it is recommended to have total lead length equal to 2.5mm minimum, measured from the package line.
4. VK package is a pin through-hole package, hence adapted for wave soldering process. A reflow soldering process is not recommended with VK package as it may seriously affect device reliability.

Marking:

- 1st Line : US90A (US91A) - Name of the device
- 2nd Line : xxxx - Assembly lot number (4 last digits)

Hall plate location

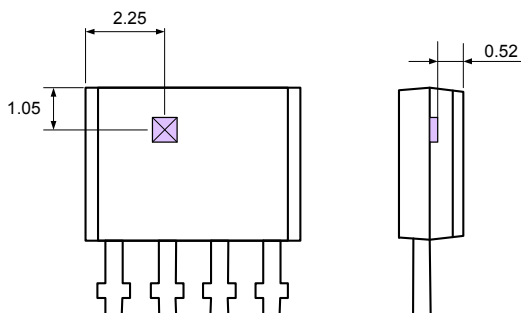

Notes:

1. All dimensions are in millimeters
2. Typical values

16.2 DC Package Information (8-pin narrow SOIC)

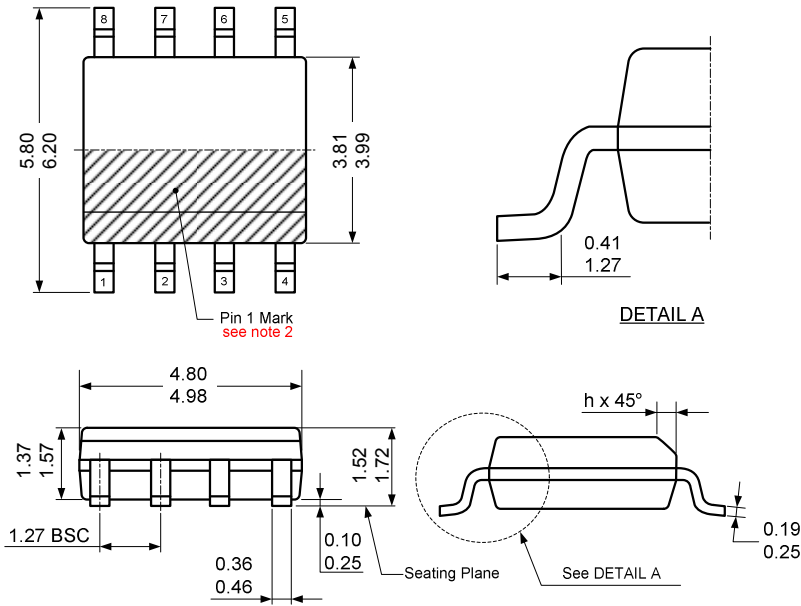

Notes:

1. Controlling dimensions in millimeters
2. Detail of pin #1 identifier are optional but must be located within the zone indicated.
3. Lead coplanarity should be to 0.10mm max.
4. All dimensions exclude mold flashes
End flash from the package body shall not exceed 0.25mm per side.

Marking:

Top Side:

- 1st Line : US90A (US91A) - Name of the device
- 2nd Line : xxxxxx - Assembly lot number

Bottom Side:

- yyww : yy = year
- ww = week

Hall plate location

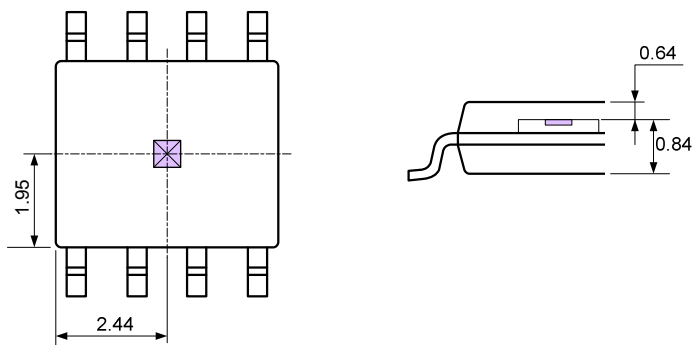

Notes:

1. All dimensions are in millimeters
2. Typical values

17 Disclaimer

Devices sold by Melexis are covered by the warranty and patent indemnification provisions appearing in its Term of Sale. Melexis makes no warranty, express, statutory, implied, or by description regarding the information set forth herein or regarding the freedom of the described devices from patent infringement. Melexis reserves the right to change specifications and prices at any time and without notice. Therefore, prior to designing this product into a system, it is necessary to check with Melexis for current information. This product is intended for use in normal commercial applications. Applications requiring extended temperature range, unusual environmental requirements, or high reliability applications, such as military, medical life-support or life-sustaining equipment are specifically not recommended without additional processing by Melexis for each application.

The information furnished by Melexis is believed to be correct and accurate. However, Melexis shall not be liable to recipient or any third party for any damages, including but not limited to personal injury, property damage, loss of profits, loss of use, interrupt of business or indirect, special incidental or consequential damages, of any kind, in connection with or arising out of the furnishing, performance or use of the technical data herein. No obligation or liability to recipient or any third party shall arise or flow out of Melexis' rendering of technical or other services.

© 2002 Melexis NV. All rights reserved.

For the latest version of this document, go to our website at
www.melexis.com

Or for additional information contact Melexis Direct:

Europe and Japan:

Phone: +32 1367 0495
E-mail: sales_europe@melexis.com

All other locations:

Phone: +1 603 223 2362
E-mail: sales_usa@melexis.com

ISO/TS 16949 and ISO14001 Certified