

IF Signal Processing for DAB

Description



The U2759B is a bipolar integrated IF signal processing circuit. It is designed for DAB (Digital Audio Broadcasting) applications.

Features

- High linearity of the complete circuit
- 3-stage gain controlled wideband amplifier
- Internal AGC loops
- AGC time constants and thresholds adjustable
- Mixer: double balanced high current Gilbert Cell

Block Diagram

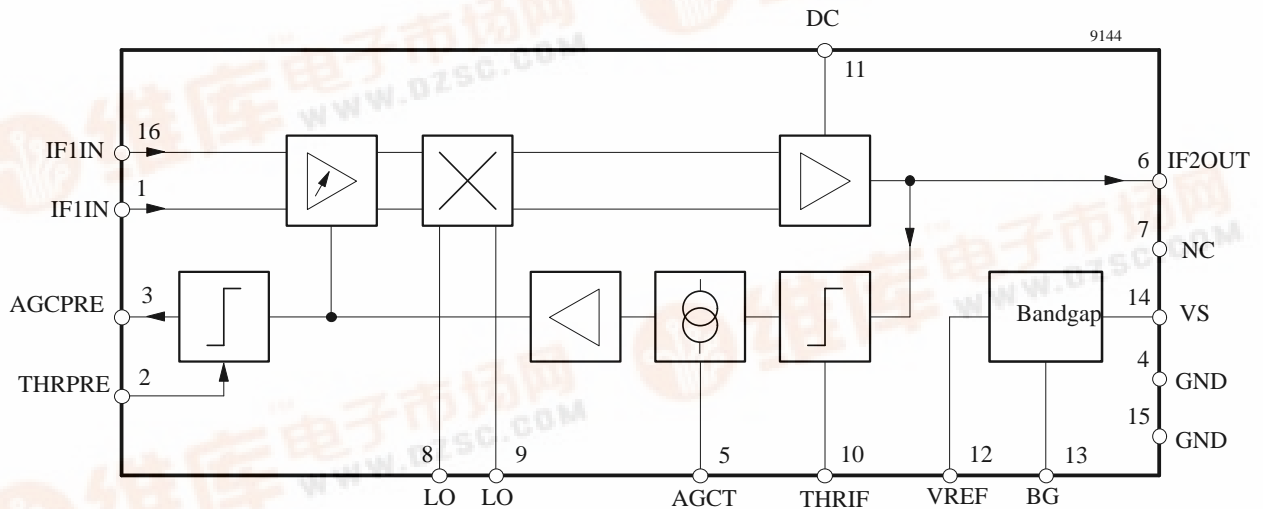

Figure 1.

Ordering and Package Information

Extended Type Number	Package	Remarks
U2759B-A	DIP16	
U2759B-AFL	SO24	
U2759B-AFLG3	SO24	Taping according ICE-286-3



Pin Description

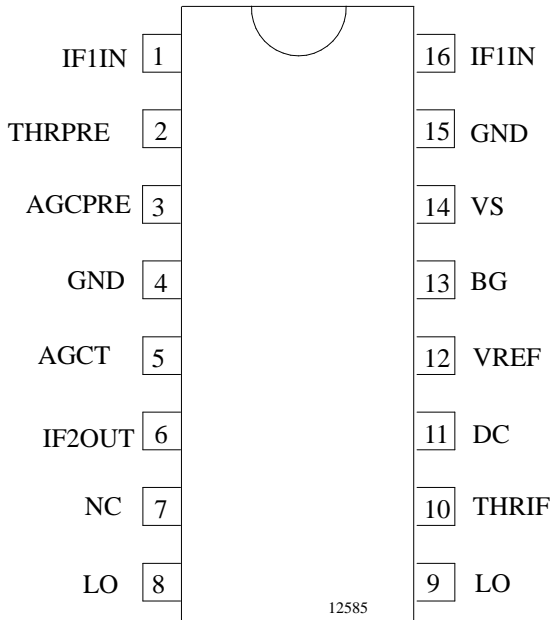

Figure 2. Pinning DIP16

Pin	Symbol	Function
1	IF1IN	IF1 input
2	THRPRE	AGC-threshold for pre-amplifier
3	AGCPRE	AGC for pre-amplifier
4	GND	Ground
5	AGCT	AGC time constant for IF amplifier
6	IF2OUT	IF2 output
7	NC	Not connected
8	LO	Local oscillator
9	LO	Local oscillator
10	THRIF	AGC-threshold for IF amplifier
11	DC	DC-level
12	VREF	Reference voltage
13	BG	Bandgap
14	VS	Supply voltage
15	GND	Ground
16	IF1IN	IF1 input

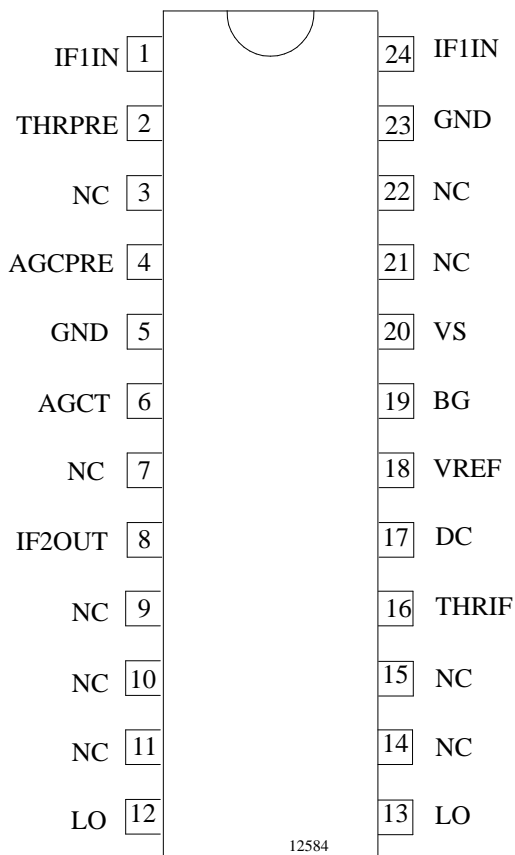

Figure 3. Pinning SO24

Pin	Symbol	Function
1	IF1IN	IF1 input
2	THRPRE	AGC-threshold for pre-amplifier
3	NC	Not connected
4	AGCPRE	AGC for pre-amplifier
5	GND	Ground
6	AGCT	AGC time constant for IF amplifier
7	NC	Not connected
8	IF2OUT	IF2 output
9	NC	Not connected
10	NC	Not connected
11	NC	Not connected
12	LO	Local oscillator
13	LO	Local oscillator
14	NC	Not connected
15	NC	Not connected
16	THRIF	AGC threshold for IF amplifier
17	DC	DC-level
18	VREF	Reference voltage
19	BG	Bandgap
20	VS	Supply voltage
21	NC	Not connected
22	NC	Not connected
23	GND	Ground
24	IF1IN	IF1 input

Pin Description for DIP16

IF1IN

The input voltage is fed via Pins 1 and 16 to the first stage of the 3 stage gain-controlled wide-band amplifier. The first stage has an internal dc voltage supply with an internal resistance of 2 kΩ to connect the SAW filters directly.

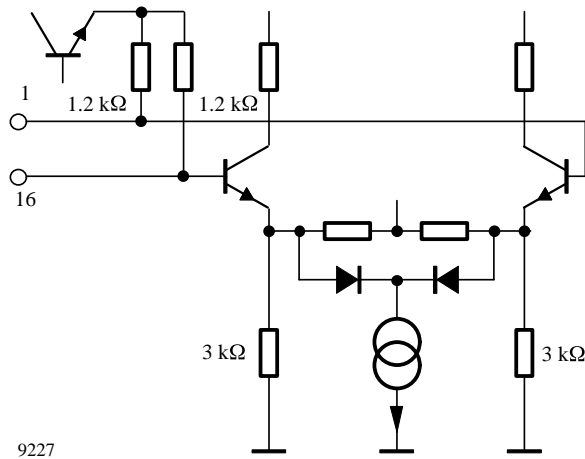

Figure 4.

THRPRE

The control of a pre-stage can be adjusted at Pin 2 by using an external potentiometer switched against ground. With increasing voltage at Pin 2, control of the (external) pre-stage does not become active until there is a high input level at IF1. If Pin 2 is not connected, the control only becomes active if the input is overdriven.

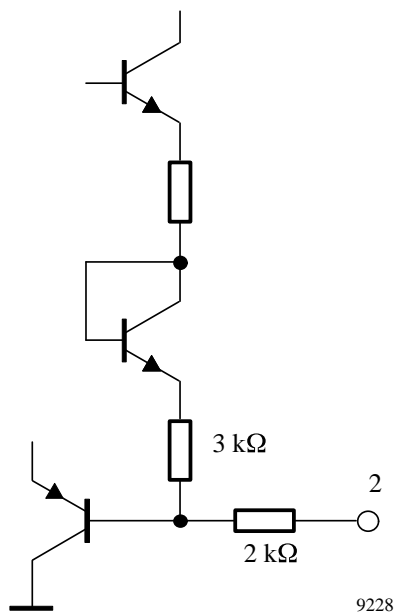

Figure 5.

AGCPRE

Pin 3 is an open-collector output. Depending on the input level, a control voltage can be generated for the external pre-stage by using an external voltage divider. This prevents an overdrive of input IF1. The threshold for activation of the open-collector output is adjusted with Pin 2.

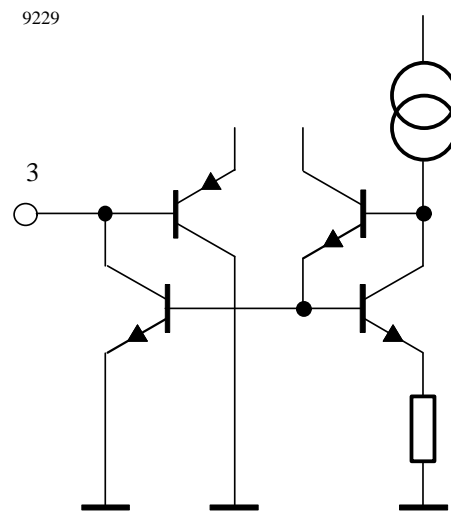

Figure 6.

IF2OUT

The product of input signal IF1 and the oscillator frequency (Pins 8 and 9) can be found at Pin 6. Here it concerns the emitter follower output with integrated current sink. The output voltage IF2 is twice as high as the difference between the voltage at Pin 10 and Pin 11.

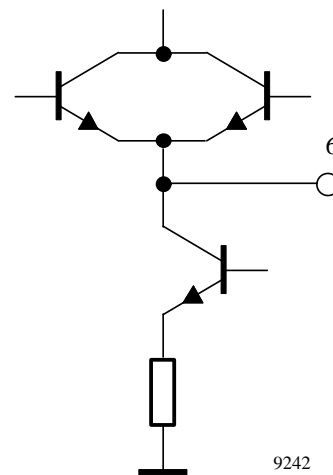

Figure 7.

LO

The externally generated oscillator frequency is supplied via crosspoint capacitances at Pin 8 and /or Pin 9. If the oscillator frequency is not symmetrically connected, each open pin has to be blocked against ground.

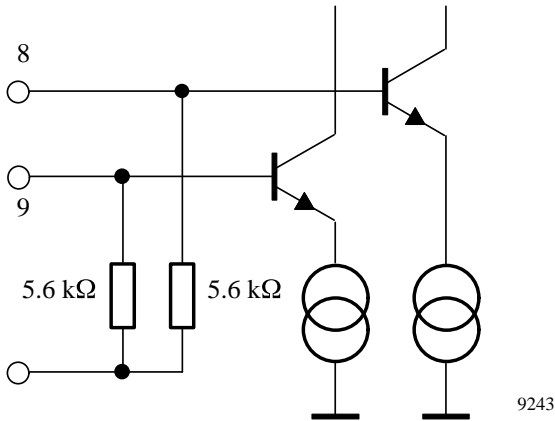

Figure 8.

DC

The dc mean value of the output signal is adjusted by using an external voltage at Pin 11. The voltage at Pin 11 always has to be higher than the voltage at Pin 10.

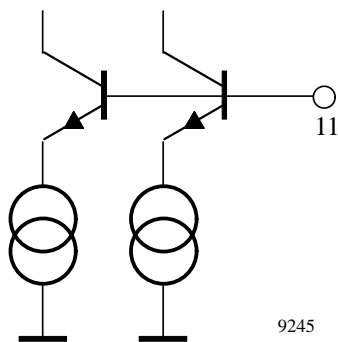

Figure 9.

AGCT

The control voltage for the wide-band amplifier is generated by using the external capacitor at Pin 5. By integration of the control current generated in the IC, there is a high control voltage if there is a large input level at IF1 and a low control voltage if there is a low input level.

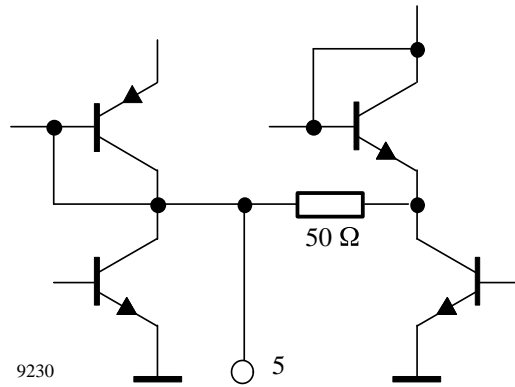

Figure 10.

THRIF

The control threshold for the AGC is adjusted by using an external voltage.

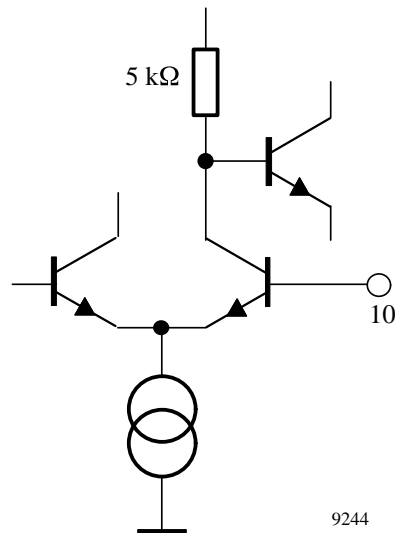

Figure 11.

VREF

A stabilized voltage is available at Pin 12 on to which an external voltage divider for supplying Pin 10 and Pin 11 can be connected.

At Pin 13, the internally generated temperature stable reference voltage is blocked against ground. This voltage must not be loaded by external circuitry.

More information concerning the parameters:

Noise ratio of all ICs:
Typically 11.2 dB (SSB)

Intercept point 3rd order:
Typically 58 dB ($2 V_{SS}$ at Pin 6)

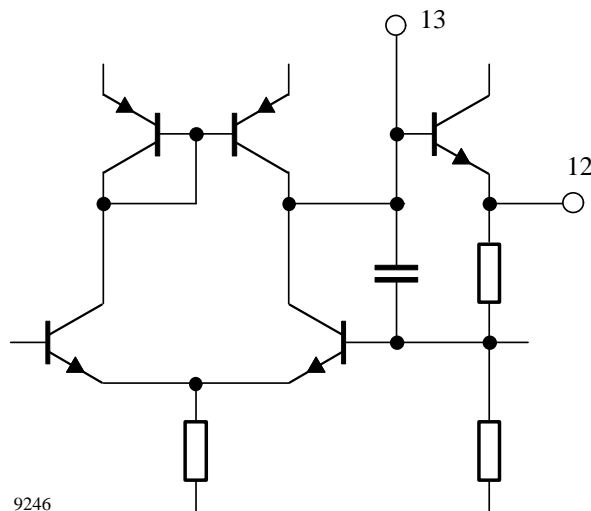

Figure 12.

Functional Description

The U2759B consists of a controllable wideband amplifier, a mixer and AGC-block.

The input voltage V_{if1} is applied at Pin 1 and 16 and it is fed via a 3-stage controlled wideband amplifier to the mixer. The oscillator voltage can be applied symmetrically as well as unsymmetrically.

The mixed signal is used in order to generate the AGC-voltage. The mixed signal therefore is fed to a comparator which charges or discharges an external capacitor dependent on the signal level. The threshold of the comparator can be adjusted externally. The generated voltage controls the wideband amplifier.

The generated control voltage can be used also for an additional external preamplifier. This AGC protects the IF1 input against overload.

The amplitude as well as the superimposed DC-level of the output voltage V_{IF2} can be adjusted by an external voltage. V_{REF} is therefore available at Pin 12 (max. $500 \mu A$).

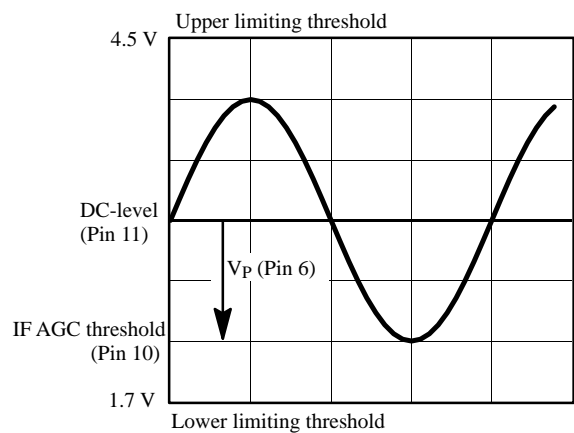

12586

Figure 13. Adjustment of output level

Absolute Maximum Ratings

Reference point Pin 4, unless otherwise specified

Parameters	Symbol	Value	Unit
Supply voltage	V_S	10	V
Supply current Pin 14	I_S	55	mA
Output current Pin 6	I_{OUT}	5.0	mA
Max. power dissipation	P	550	mW
Junction temperature	T_j	+125	°C
Ambient temperature range	T_{amb}	-40 to +85	°C
Storage temperature range	T_{stg}	-40 to +125	°C

Thermal Resistance

Parameters	Symbol	Value	Unit
Junction ambient DIP16	R_{thJA}	60	K/W
Junction ambient SO24	R_{thJA}	60	K/W

Electrical Characteristics

$T_{amb} = 25^\circ\text{C}$, $V_S = 8\text{ V}$, reference point Pin 4, unless otherwise specified

Parameters	Test Conditions / Pins	Symbol	Min.	Typ.	Max.	Unit
DC-supply Pin 14						
Supply voltage		V_S	6.8	8.0	10.0	V
Supply current		I_S		45	55	mA
IF-amplifier Pin 1 to 16						
Input sensitivity	2 V _{pp} at Pin 6	V_{in}		80	120	μV_{rms}
Input impedance		R_{in}		1.2		k Ω
Input capacitance		C_{in}		2		pF
IF-AGC Pin 5						
IF gain control range		G_V	60	66		dB
AGC capacitor		C_5		4.7		μF
Preamp-AGC Pin 3						
Available -AGC current		I_3		4		mA
IF2 output Pin 6						
IF2-Signal bandwidth (-3dB)		B	12			MHz
Lower limiting threshold		ΔV_{lim1}		1.7		V
Upper limiting threshold		ΔV_{lim2}		4.5		V
Signal adjustm. Pin 10,11,12						
DC level (external)		V_{11}	2		4	V
Reference voltage	Pin 12	V_{ref}		5.2		V
Available current	Pin 12	$I(V_{ref})$			500	μA

Application Circuit

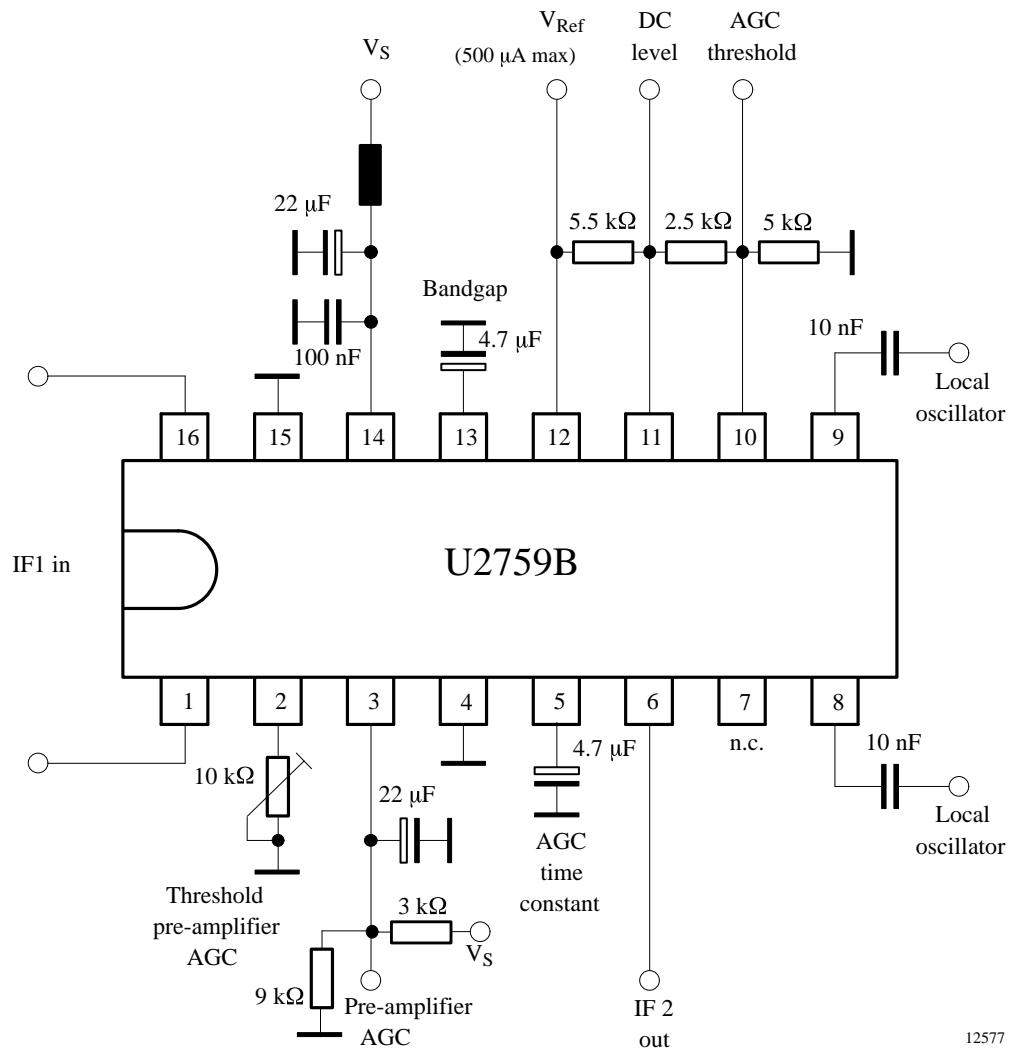
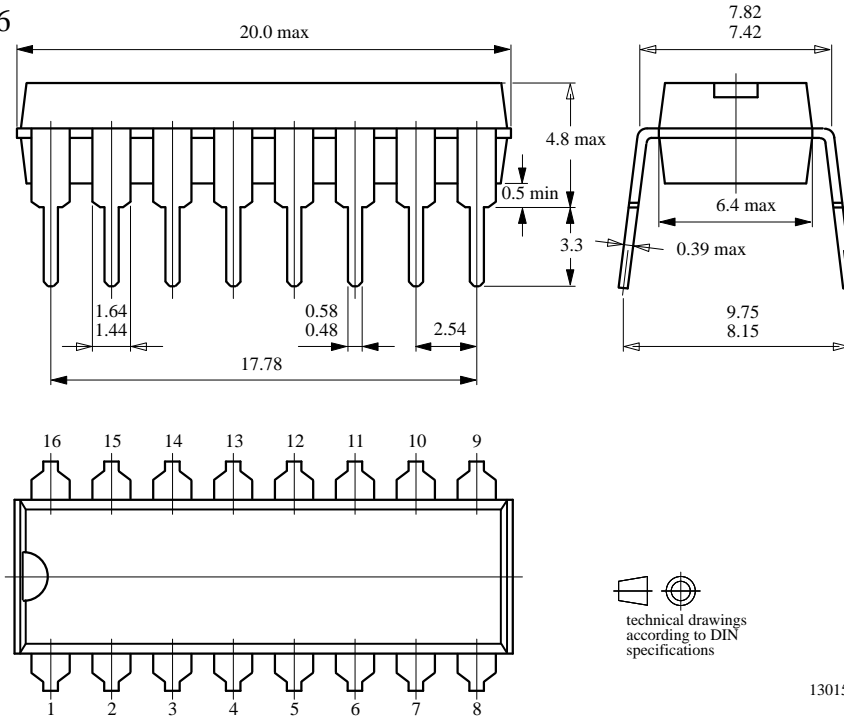

Figure 14.

U2759B

Dimensions in mm

Package DIP16



13015

Package SO24

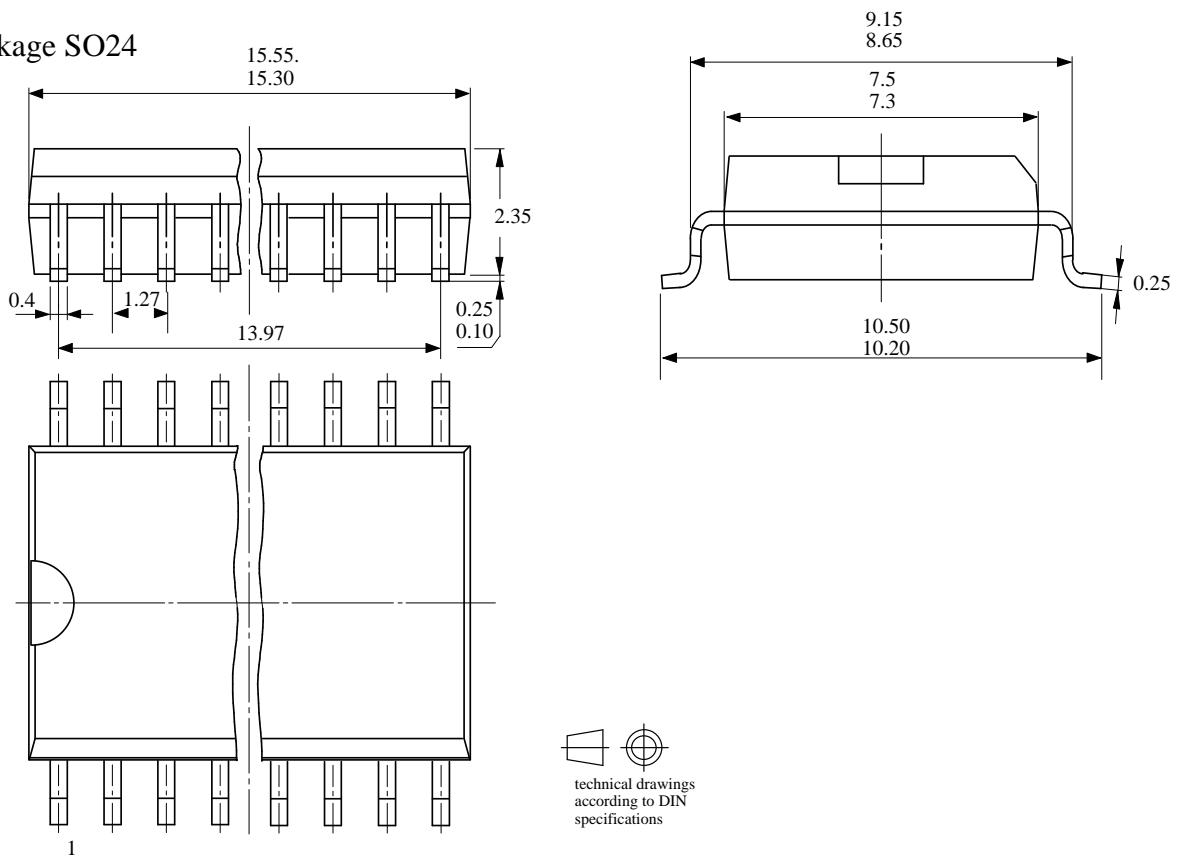

Ozone Depleting Substances Policy Statement

It is the policy of **TEMIC TELEFUNKEN microelectronic GmbH** to

1. Meet all present and future national and international statutory requirements.
2. Regularly and continuously improve the performance of our products, processes, distribution and operating systems with respect to their impact on the health and safety of our employees and the public, as well as their impact on the environment.

It is particular concern to control or eliminate releases of those substances into the atmosphere which are known as ozone depleting substances (ODSs).

The Montreal Protocol (1987) and its London Amendments (1990) intend to severely restrict the use of ODSs and forbid their use within the next ten years. Various national and international initiatives are pressing for an earlier ban on these substances.

TEMIC TELEFUNKEN microelectronic GmbH semiconductor division has been able to use its policy of continuous improvements to eliminate the use of ODSs listed in the following documents.

1. Annex A, B and list of transitional substances of the Montreal Protocol and the London Amendments respectively
2. Class I and II ozone depleting substances in the Clean Air Act Amendments of 1990 by the Environmental Protection Agency (EPA) in the USA
3. Council Decision 88/540/EEC and 91/690/EEC Annex A, B and C (transitional substances) respectively.

TEMIC can certify that our semiconductors are not manufactured with ozone depleting substances and do not contain such substances.

We reserve the right to make changes to improve technical design and may do so without further notice.

Parameters can vary in different applications. All operating parameters must be validated for each customer application by the customer. Should the buyer use TEMIC products for any unintended or unauthorized application, the buyer shall indemnify TEMIC against all claims, costs, damages, and expenses, arising out of, directly or indirectly, any claim of personal damage, injury or death associated with such unintended or unauthorized use.

TEMIC TELEFUNKEN microelectronic GmbH, P.O.B. 3535, D-74025 Heilbronn, Germany
Telephone: 49 (0)7131 67 2831, Fax number: 49 (0)7131 67 2423