



# UNISONIC TECHNOLOGIES CO., LTD

## U74AHCT1G125

CMOS IC

### SINGLE BUS BUFFER GATE WITH 3-STATE OUTPUT

#### DESCRIPTION

The U74AHCT1G125 is a single bus buffer gate with 3-state output controlled by enable input ( $\overline{OE}$ ). When  $\overline{OE}$  is HIGH, the output is disabled.

#### FEATURES

- \* Operation Voltage Range: 4.5~5.5V
- \* Low Power Dissipation: 10uA(Max)
- \* Inputs are TTL-Voltage Compatible

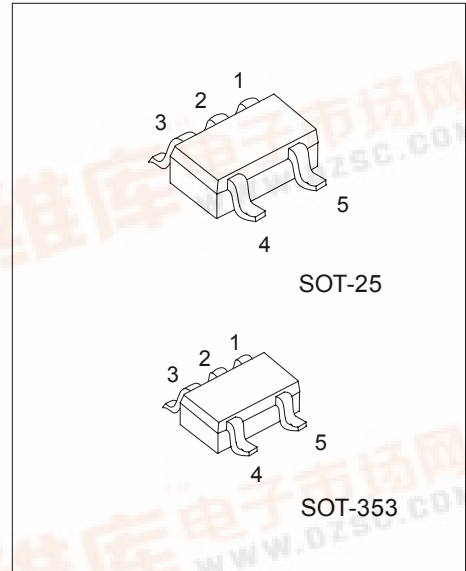

\*Pb-free plating product number:  
U74AHCT1G125L

#### ORDERING INFORMATION

Order Number		Package	Packing
Normal	Lead Free Plating		
U74AHCT1G125-AF5-R	U74AHCT1G125L-AF5-R	SOT-25	Tape Reel
U74AHCT1G125-AL5-R	U74AHCT1G125L-AL5-R	SOT-353	Tape Reel

<p>U74AHCT1G125L-AF5-R</p>	<p>(1) R: Tape Reel (2) AF5: SOT-25, AL5: SOT-353 (3) L: Lead Free Plating, Blank: Pb/Sn</p>
----------------------------	--

#### MARKING

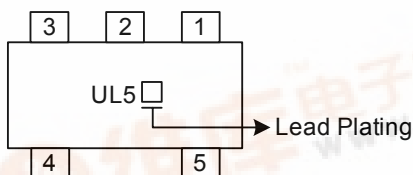

# U74AHCT1G125

CMOS IC

## ■ PIN CONFIGURATION

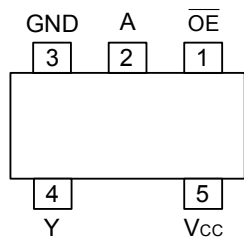

## ■ FUNCTION TABLE (each gate)

INPUT		OUTPUT
$\overline{OE}$	A	Y
L	L	L
L	H	H
H	X	Z

## ■ LOGIC DIAGRAM (positive logic)

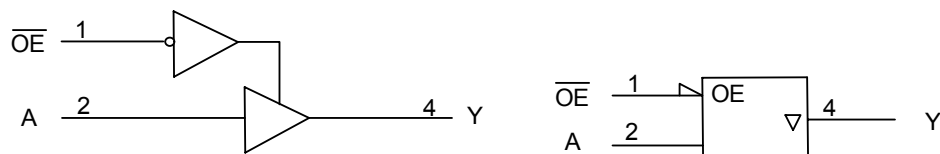

## ■ ABSOLUTE MAXIMUM RATINGS (unless otherwise specified)(Note 1)

PARAMETER	SYMBOL	RATINGS	UNIT
Supply Voltage	V <sub>CC</sub>	-0.5~7	V
Input Voltage	V <sub>IN</sub>	-0.5~7	V
Output Voltage	V <sub>OUT</sub>	-0.5~V <sub>CC</sub> +0.5	V
Input Clamp Current	I <sub>IK</sub>	-20	mA
Output Clamp Current	I <sub>OK</sub>	±20	mA
Output Current	I <sub>OUT</sub>	±25	mA
V <sub>CC</sub> or GND Current	I <sub>CC</sub>	±50	mA
Storage Temperature	T <sub>STG</sub>	-65 ~ +150	

Note 1. The input and output voltage ratings may be exceeded if the input and output current ratings are observed.

2. Absolute maximum ratings are those values beyond which the device could be permanently damaged.

Absolute maximum ratings are stress ratings only and functional device operation is not implied.

## ■ RECOMMENDED OPERATING CONDITIONS

PARAMETER	SYMBOL	CONDITIONS	MIN	TYP	MAX	UNIT
Supply Voltage	V <sub>CC</sub>		4.5		5.5	V
Input Voltage	V <sub>IN</sub>		0		5.5	V
Output Voltage	V <sub>OUT</sub>		0		V <sub>CC</sub>	V
Input Transition Rise or Fall Rate	Δt/ΔV	V <sub>CC</sub> =5.0+0.5V			20	ns/V
Operating Temperature	T <sub>A</sub>		-40		85	

## ■ STATIC CHARACTERISTICS (T<sub>A</sub>=25 °C)

PARAMETER	SYMBOL	TEST CONDITIONS	MIN	TYP	MAX	UNIT
Input Voltage	High-Level	V <sub>IH</sub>	V <sub>CC</sub> =4.5V~5.5V	2		V
	Low-Level	V <sub>IL</sub>	V <sub>CC</sub> =4.5V~5.5V			0.8
Output Voltage	High-Level	V <sub>OH</sub>	V <sub>CC</sub> =4.5V, I <sub>OH</sub> =-50μA	4.4	4.5	
			V <sub>CC</sub> =4.5V, I <sub>OH</sub> =-8mA	3.94		
	Low-Level	V <sub>OL</sub>	V <sub>CC</sub> =4.5V, I <sub>OL</sub> =50μA			0.1
			V <sub>CC</sub> =4.5V, I <sub>OH</sub> =8mA			0.36
Input Leakage Current	I <sub>I(LEAK)</sub>	V <sub>CC</sub> =0V~5.5V, V <sub>IN</sub> =V <sub>CC</sub> or GND			±0.1	μA
Output Current, OFF-state	I <sub>OZ</sub>	V <sub>CC</sub> =5.5V, V <sub>OUT</sub> =V <sub>CC</sub> or GND			±0.25	μA
Quiescent Supply Current	I <sub>Q</sub>	V <sub>CC</sub> =5.5V, V <sub>IN</sub> =V <sub>CC</sub> or GND, I <sub>OUT</sub> =0			1	μA
Additional Quiescent Supply Current	ΔI <sub>CC</sub>	V <sub>CC</sub> =5.5V, One input at 3.4V, Other input at V <sub>CC</sub> or GND			1.35	mA
Input Capacitance	C <sub>IN</sub>	V <sub>CC</sub> =5V, V <sub>IN</sub> =V <sub>CC</sub> or GND		4	10	pF
Output Capacitance	C <sub>OUT</sub>	V <sub>CC</sub> =5V, V <sub>OUT</sub> =V <sub>CC</sub> or GND		10		pF

## ■ DYNAMIC CHARACTERISTICS (T<sub>A</sub>=25 °C, Input: t<sub>R</sub>, t<sub>F</sub>≤3ns; PRR≤1MHz)

PARAMETER	SYMBOL	TEST CONDITIONS	MIN	TYP	MAX	UNIT
Propagation Delay From A to Y	t <sub>PLH</sub>	V <sub>CC</sub> =5V±0.5V, C <sub>L</sub> =15pF		3.8	5.5	ns
	t <sub>PHL</sub>			3.8	5.5	
Turn-On Time $\overline{OE}$ to Y	t <sub>PZH</sub>	V <sub>CC</sub> =5V±0.5V, C <sub>L</sub> =15pF		3.6	5.1	ns
	t <sub>PZL</sub>			3.6	5.1	
Turn-Off Time $\overline{OE}$ to Y	t <sub>PHZ</sub>	V <sub>CC</sub> =5V±0.5V, C <sub>L</sub> =15pF		4.6	6.8	ns
	t <sub>PLZ</sub>			4.6	6.8	
Propagation Delay From A to Y	t <sub>PLH</sub>	V <sub>CC</sub> =5V±0.5V, C <sub>L</sub> =50pF		5.3	7.5	ns
	t <sub>PHL</sub>			5.3	7.5	
Turn-On Time $\overline{OE}$ to Y	t <sub>PZH</sub>	V <sub>CC</sub> =5V±0.5V, C <sub>L</sub> =50pF		5.1	7.1	ns
	t <sub>PZL</sub>			5.1	7.1	
Turn-Off Time $\overline{OE}$ to Y	t <sub>PHZ</sub>	V <sub>CC</sub> =5V±0.5V, C <sub>L</sub> =50pF		6.1	8.8	ns
	t <sub>PLZ</sub>			6.1	8.8	

## OPERATING CHARACTERISTICS

Power Dissipation Capacitance	C <sub>pd</sub>	No load, f=1MHz, V <sub>CC</sub> =5			14	pF
-------------------------------	-----------------	-------------------------------------	--	--	----	----

## TEST CIRCUIT AND WAVEFORMS

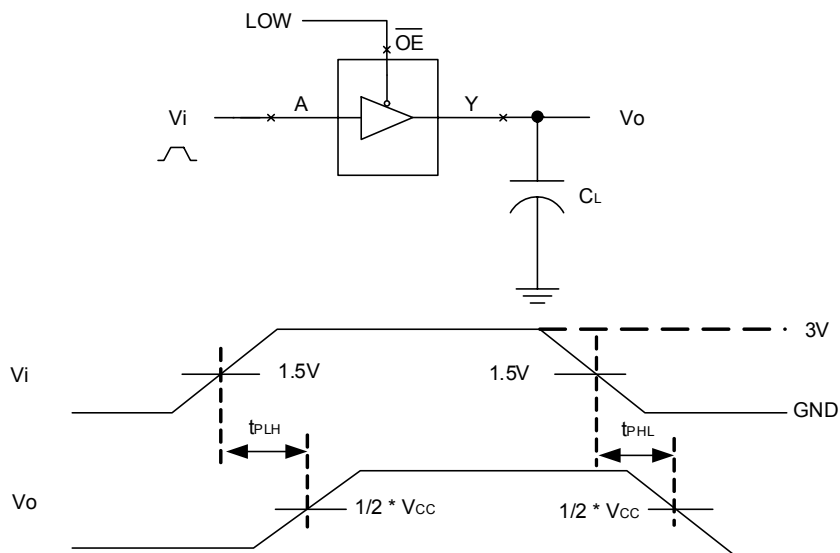

Note:  $C_L$  includes probe and jig capacitance.

Fig-1 Propagation delay from A to Y

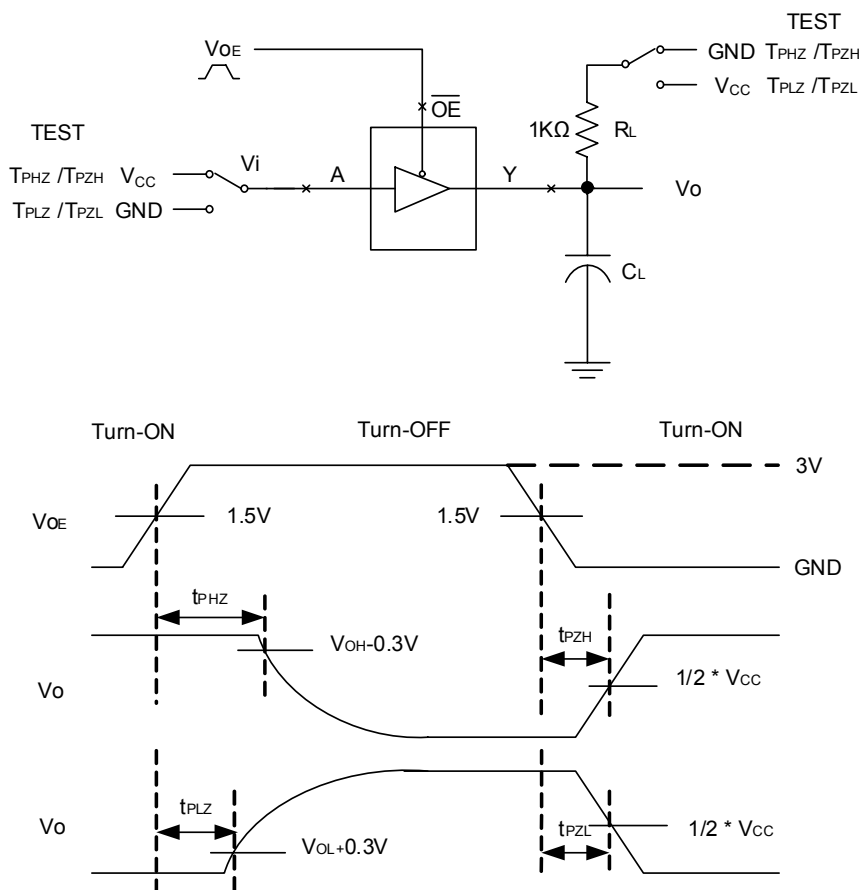

Fig-2 The turn-on and turn-off times.

UTC assumes no responsibility for equipment failures that result from using products at values that exceed, even momentarily, rated values (such as maximum ratings, operating condition ranges, or other parameters) listed in products specifications of any and all UTC products described or contained herein. UTC products are not designed for use in life support appliances, devices or systems where malfunction of these products can be reasonably expected to result in personal injury. Reproduction in whole or in part is prohibited without the prior written consent of the copyright owner. The information presented in this document does not form part of any quotation or contract, is believed to be accurate and reliable and may be changed without notice.