

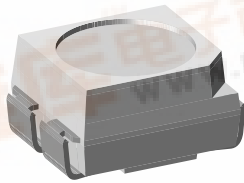

VLMW32..

Vishay Semiconductors

Power SMD LED PLCC-4



19210_1

DESCRIPTION

The VLMW32.. white LED is an advanced product in terms of heat dissipation.

The leadframe profile of this PLCC-4 SMD package is optimized to reduce the thermal resistance.

This allows higher drive current and doubles the light output compared to Vishay's high intensity SMD LED in PLCC-2 standard package.

PRODUCT GROUP AND PACKAGE DATA

- Product group: LED
- Package: PLCC-4
- Product series: SMD Power
- Angle of half intensity: $\pm 60^\circ$

FEATURES

- High efficient INGaN technology
- Angle of half intensity $\varphi = \pm 60^\circ$
- Available in 8 mm tape
- Luminous intensity, color and forward voltage categorized per packing unit
- Luminous intensity ratio per packing unit $I_{Vmax}/I_{Vmin} \leq 1.6$
- ESD-withstand voltage: up to 1 kV according to JESD22-A114-B
- Lead (Pb)-free device
- Preconditioning: according to Jedec Level 2a
- Compatible with IR-Reflow, vapor phase and wave soldering processes according to CECC 00802 and J-STD-020C
- Component in accordance to RoHS 2002/95/EC and WEEE 2002/96/EC
- Automotive qualified AEC-Q101



APPLICATIONS

- Camera flash light
- Signal and symbol luminaire
- Marker lights
- Interior and exterior automotive lighting (brake lights, turn lights, backlighting, side markers)
- Indicator lighting

PARTS TABLE

PART	COLOR, LUMINOUS INTENSITY	TECHNOLOGY WAVELENGTH
VLMW32T2V1-5K8L-08	White, $I_V = (355 \text{ to } 900) \text{ mcd}$	InGaN/TAG on SiC
VLMW32T2V1-5K8L-18	White, $I_V = (355 \text{ to } 900) \text{ mcd}$	InGaN/TAG on SiC
VLMW32U2V2-5K8L-08	White, $I_V = (560 \text{ to } 1120) \text{ mcd}$	InGaN/TAG on SiC
VLMW32U2V2-5K8L-18	White, $I_V = (560 \text{ to } 1120) \text{ mcd}$	InGaN/TAG on SiC
VLMW32T1V2-5K8L-08	White, $I_V = (280 \text{ to } 1120) \text{ mcd}$	InGaN/TAG on SiC
VLMW32T1V2-5K8L-18	White, $I_V = (280 \text{ to } 1120) \text{ mcd}$	InGaN/TAG on SiC
VLMW32U2AA-5K8L-08	White, $I_V = (560 \text{ to } 1400) \text{ mcd}$	InGaN/TAG on SiC
VLMW32U2AA-5K8L-18	White, $I_V = (560 \text{ to } 1400) \text{ mcd}$	InGaN/TAG on SiC
VLMW32V2AB-5K8L-08	White, $I_V = (900 \text{ to } 1800) \text{ mcd}$	InGaN/TAG on SiC
VLMW32V2AB-5K8L-18	White, $I_V = (900 \text{ to } 1800) \text{ mcd}$	InGaN/TAG on SiC

VLMW32..

Vishay Semiconductors



ABSOLUTE MAXIMUM RATINGS ¹⁾ VLMW32..				
PARAMETER	TEST CONDITION	SYMBOL	VALUE	UNIT
Reverse voltage ²⁾		V_R	5	V
DC Forward current	$T_{amb} \leq 65\text{ }^\circ\text{C}$	I_F	30	mA
Surge forward current	$t_p \leq 10\text{ }\mu\text{s}$	I_{FSM}	0.1	A
Power dissipation		PV	127	mW
Junction temperature		T_j	100	$^\circ\text{C}$
Operating temperature range		T_{amb}	- 40 to + 100	$^\circ\text{C}$
Storage temperature range		T_{stg}	- 40 to + 100	$^\circ\text{C}$
Soldering temperature	$t \leq 5\text{ s}$	T_{sd}	260	$^\circ\text{C}$
Thermal resistance junction/ambient	mounted on PC board (pad design see page 6)	R_{thJA}	270	K/W

Note:

¹⁾ $T_{amb} = 25\text{ }^\circ\text{C}$, unless otherwise specified

²⁾ Driving the LED in reverse direction is suitable for a short term application

OPTICAL AND ELECTRICAL CHARACTERISTICS ¹⁾ VLMW32.., WHITE							
PARAMETER	TEST CONDITION	PART	SYMBOL	MIN	TYP.	MAX	UNIT
Luminous intensity	$I_F = 30\text{ mA}$	VLMW32T2V1-5K8L	I_V	355		900	mcd
		VLMW32U2V2-5K8L	I_V	560		1120	mcd
		VLMW32T1V2-5K8L	I_V	280		1120	mcd
		VLMW32U2AA-5K8L	I_V	560		1400	mcd
		VLMW32V2AB-5K8L	I_V	900		1800	mcd
Luminous Flux	$I_F = 30\text{ mA}$	VLMW32T2V1-5K8L	ϕ_V	1100		2800	mlm
		VLMW32U2V2-5K8L	ϕ_V	1700		3500	mlm
		VLMW32T1V2-5K8L	ϕ_V	860		3500	mlm
		VLMW32U2AA-5K8L	ϕ_V	1736		4340	mlm
		VLMW32V2AB-5K8L	ϕ_V	2790		5580	mlm
Chromaticity coordinate x, y acc. to CIE 1931	$I_F = 30\text{ mA}$		x		0.33		
			y		0.33		
Angle of half intensity	$I_F = 30\text{ mA}$		φ		± 60		deg
Forward voltage	$I_F = 30\text{ mA}$		V_F		3.7	4.2	V
Reverse voltage	$I_R = 10\text{ }\mu\text{A}$		V_R	5			V
Temperature coefficient of V_F	$I_F = 20\text{ mA}$		TC_{VF}		- 4		mV/K
Temperature coefficient of I_V	$I_F = 20\text{ mA}$		TC_{IV}		- 0.5		%/K

Note:

¹⁾ $T_{amb} = 25\text{ }^\circ\text{C}$, unless otherwise specified



LUMINOUS INTENSITY CLASSIFICATION		
GROUP	LIGHT INTENSITY (MCD)	
	MIN	MAX
STANDARD		
T1	280	355
T2	355	450
U1	450	560
U2	560	710
V1	710	900
V2	900	1120
AA	1120	1400
AB	1400	1800

CROSSING TABLE		
VISHAY	OSRAM	NICHIA
VLMW32T2V1	LWE67C-T2V1	NSCW021T
VLMW32U2V2	LWE67C-U2V2	NSCW021T
VLMW32T1V2	LWE67C-T1V2	NSCW021T
VLMW32U2AA	LWE6SC-U2AA	NSCW021T
VLMW32V2AB	LWE6SC-V2AB	NSCW021T

Note:

Luminous intensity is tested at a current pulse duration of 25 ms and an accuracy of $\pm 11\%$.

The above type numbers represent the order groups which include only a few brightness groups. Only one group will be shipped on each reel (there will be no mixing of two groups on each reel).

In order to ensure availability, single brightness groups will not be orderable.

In a similar manner for colors where wavelength groups are measured and binned, single wavelength groups will be shipped on any one reel.

In order to ensure availability, single wavelength groups will not be orderable.

CHROMATICITY COORDINATED GROUPS FOR WHITE SMD LED					
	X	Y		X	Y
5L	0.291	0.268	7L	0.330	0.330
	0.285	0.279		0.330	0.347
	0.307	0.312		0.347	0.371
	0.310	0.297		0.345	0.352
5K	0.296	0.259	7K	0.330	0.310
	0.291	0.268		0.330	0.330
	0.310	0.297		0.338	0.342
	0.313	0.284		0.352	0.344
6L	0.310	0.297	8L	0.345	0.352
	0.307	0.312		0.347	0.371
	0.330	0.347		0.367	0.401
	0.330	0.330		0.364	0.380
6K	0.313	0.284	8K	0.352	0.344
	0.310	0.297		0.338	0.342
	0.330	0.330		0.364	0.380
	0.330	0.310		0.360	0.357

Note:

Chromaticity coordinate groups are tested at a current pulse duration of 25 ms and a tolerance of ± 0.01 .



TYPICAL CHARACTERISTICS

$T_{amb} = 25\text{ }^{\circ}\text{C}$, unless otherwise specified

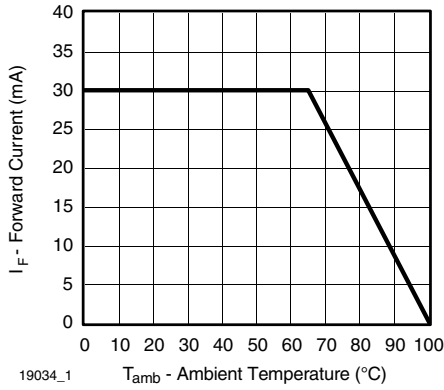

Figure 1. Forward Current vs. Ambient Temperature

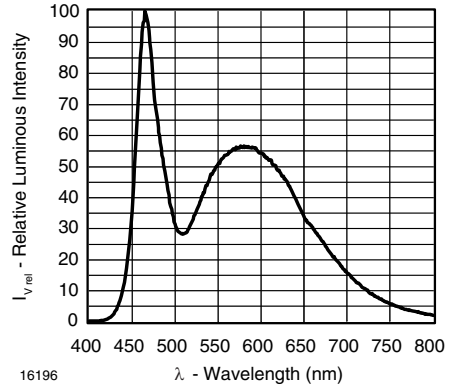

Figure 4. Relative Intensity vs. Wavelength

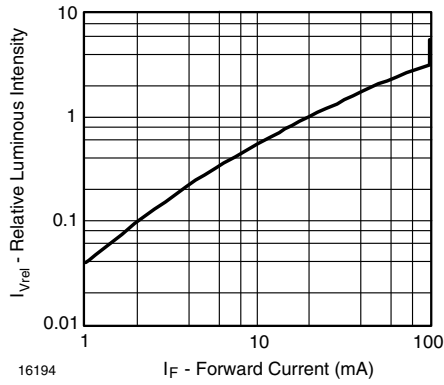

Figure 2. Relative Luminous Intensity vs. Forward Current

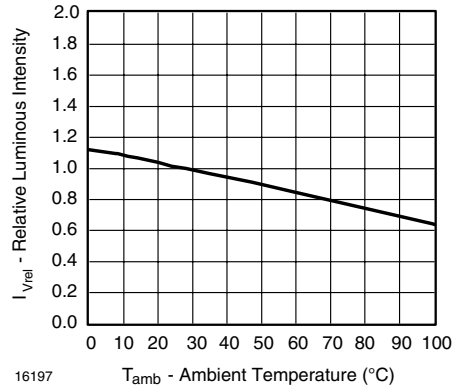

Figure 5. Rel. Luminous Intensity vs. Ambient Temperature

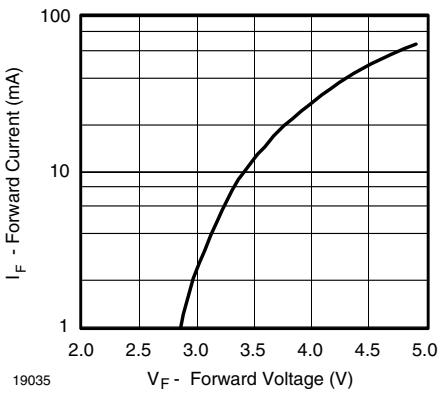

Figure 3. Forward Current vs. Forward Voltage

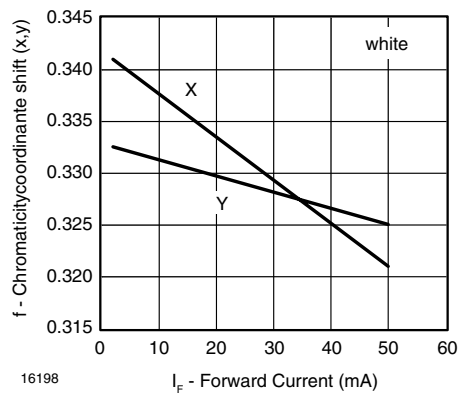

Figure 6. Chromaticity Coordinate Shift vs. Forward Current

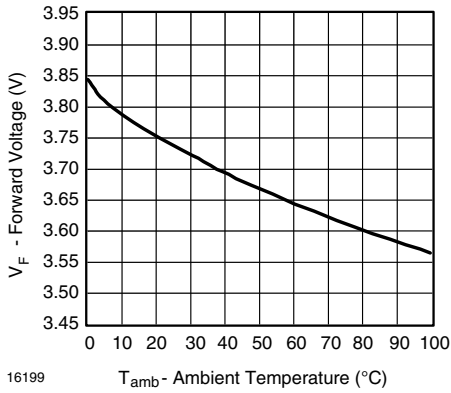

Figure 7. Forward Voltage vs. Ambient Temperature

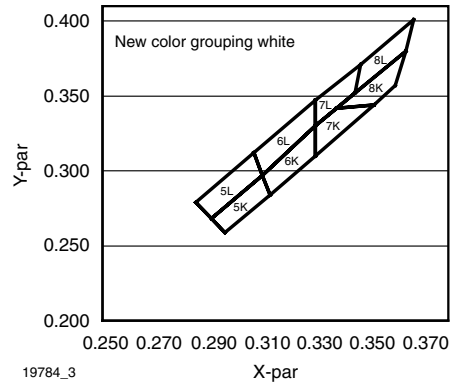

Figure 9. White Grouping SMD

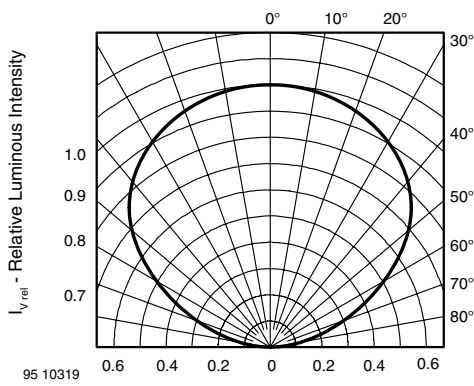

Figure 8. Rel. Luminous Intensity vs. Angular Displacement

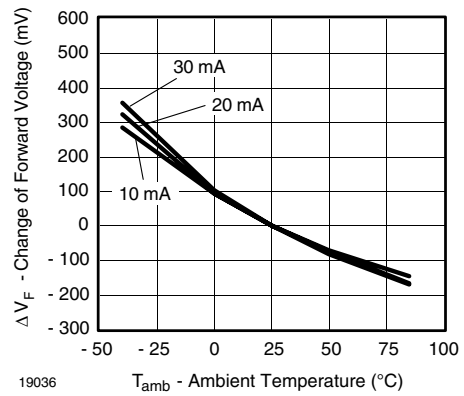
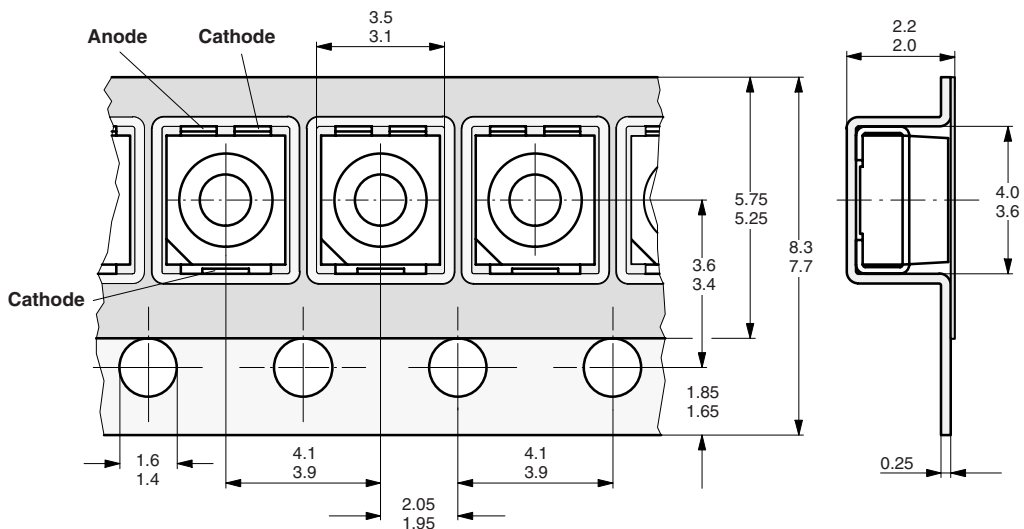

Figure 10. Change of Forward Voltage vs. Ambient Temperature

TAPING Dimensions in millimeters



18596

VLMW32..

Vishay Semiconductors



RECOMMENDED PAD DESIGN Dimensions in millimeters
(Wave-Soldering), $R_{thJA} = 270 \text{ K/W}$

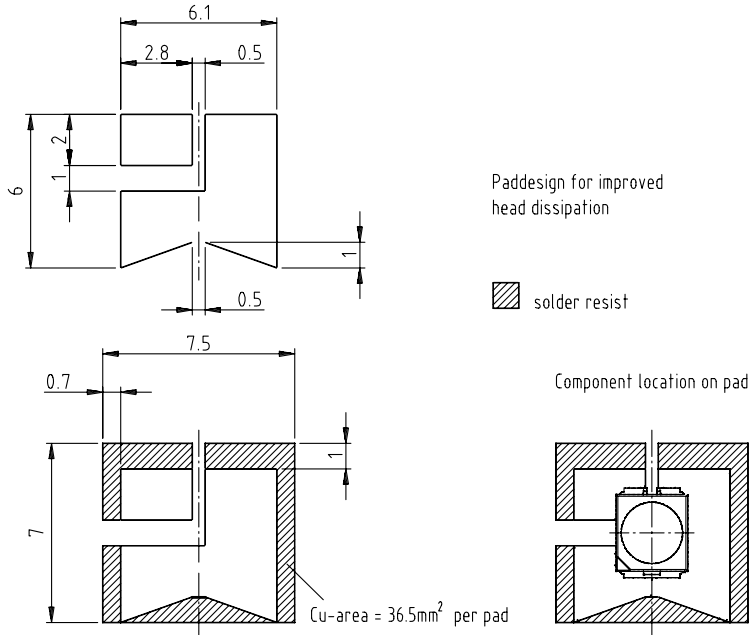

RECOMMENDED PAD DESIGN Dimensions in millimeters
(Reflow-Soldering), $R_{thJA} = 270 \text{ K/W}$

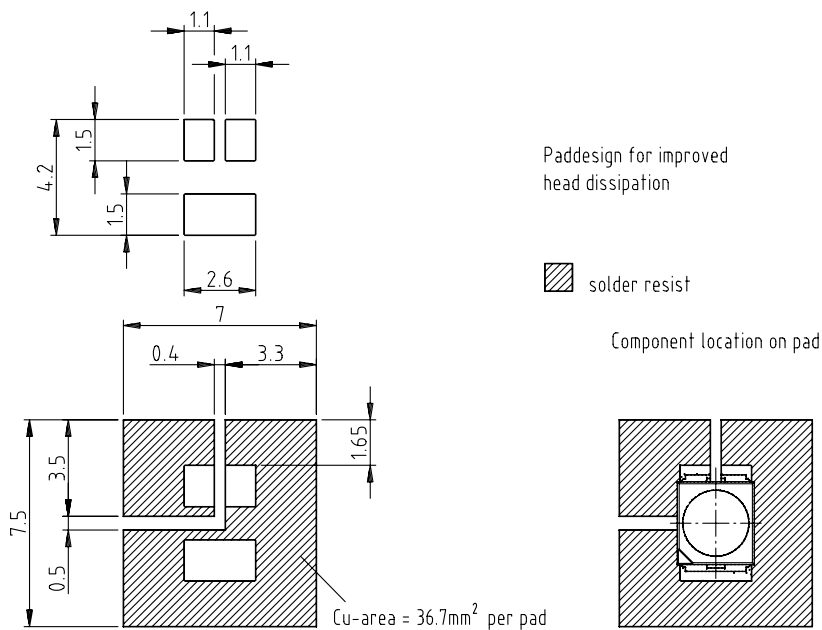



OPTIONAL PAD DESIGN Dimensions in millimeters
(Wave-Soldering), $R_{thJA} = 290 \text{ K/W}$

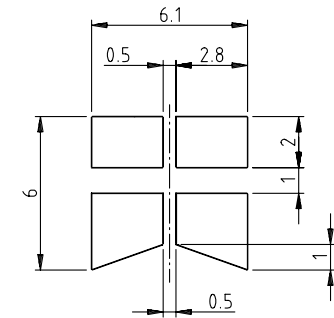

Optional pad design

 solder resist

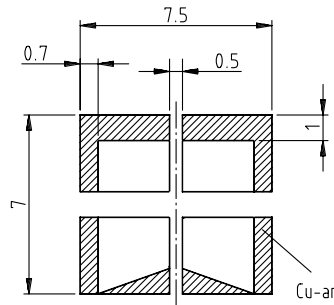

Cu-area = 10.5mm² per pad

Component location on pad

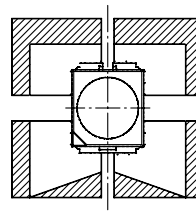

16262

OPTIONAL PAD DESIGN Dimensions in millimeters
(Reflow-Soldering), $R_{thJA} = 290 \text{ K/W}$

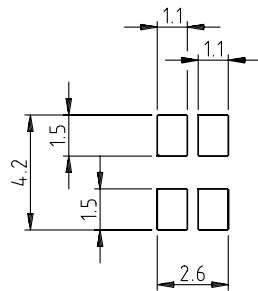

Optional pad design

 solder resist

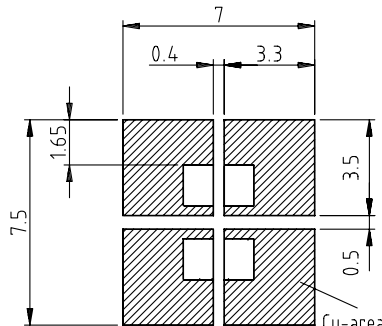

Cu-area = 11.6mm² per pad

Component location on pad

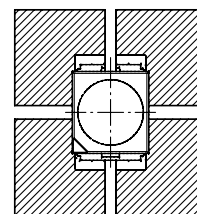

16263

PACKAGE DIMENSIONS in millimeters

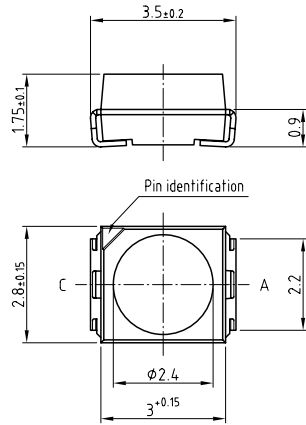

Technical drawings according to DIN specifications

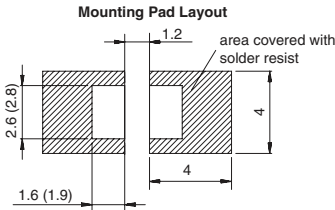

Drawing-No.: 6.541-5067.01-4
Issue: 3; 30.05.07
20541

METHOD OF TAPING/POLARITY AND TAPE AND REEL

SMD LED (VLM.3 - SERIES)

Vishay's LEDs in SMD packages are available in an antistatic 8 mm blister tape (in accordance with DIN IEC 40 (CO) 564) for automatic component insertion. The blister tape is a plastic strip with impressed component cavities, covered by a top tape.

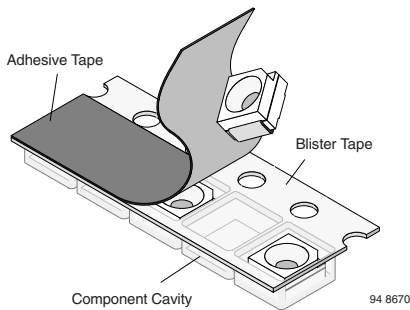

REEL PACKAGE DIMENSION IN MM FOR SMD LEDs, TAPE OPTION GS08 (= 1500 PCS.)

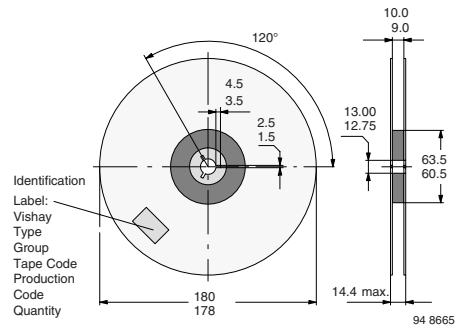

Figure 12. Reel dimensions - GS08

TAPING OF VLM.3...

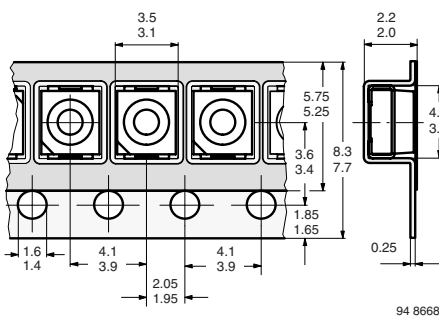

Figure 11. Tape dimensions in mm for PLCC-x

REEL PACKAGE DIMENSION IN MM FOR SMD LEDs, TAPE OPTION GS18 (= 8000 PCS.) PREFERRED

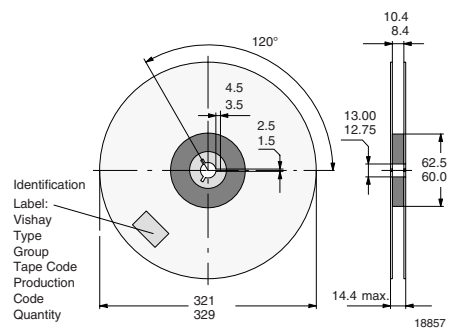

Figure 13. Reel dimensions - GS18



SOLDERING PROFILE

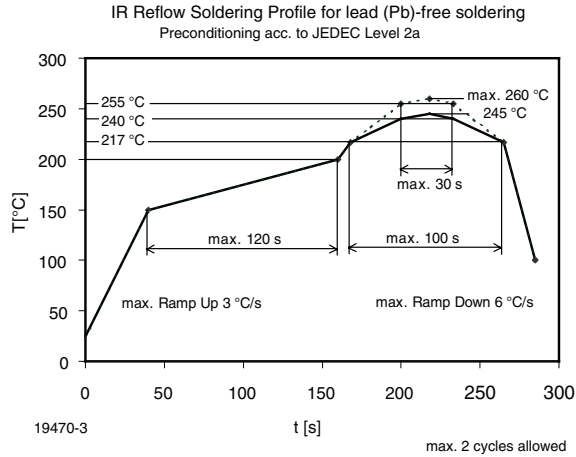

Figure 14. Vishay Lead (Pb)-free Reflow Soldering Profile (acc. to J-STD-020C)

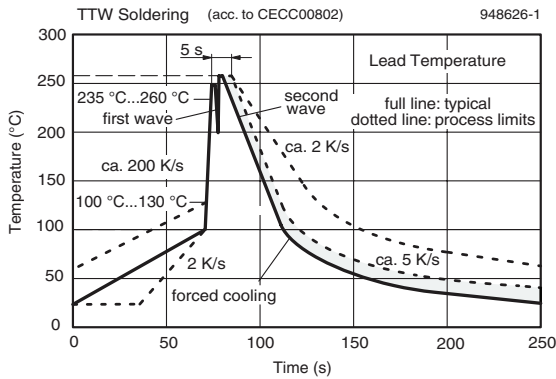
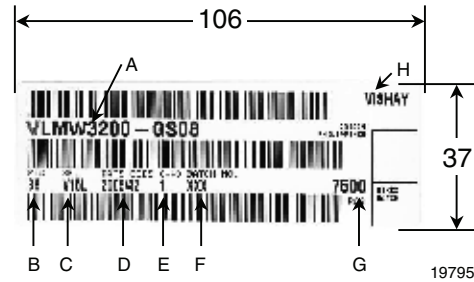

Figure 15. Double wave soldering of opto devices (all packages)

BARCODE-PRODUCT-LABEL EXAMPLE:



- A) Type of component
- B) Manufacturing plant
- C) SEL - Selection Code (Bin):
e.g.: V1 = Code for Luminous Intensity Group
5L = Code for Chrom. Coordinate Group
- D) Date Code year/week
- E) Day Code (e. g. 1: Monday)
- F) Batch No.
- G) Total quantity
- H) Company code

DRY PACKING

The reel is packed in an anti-humidity bag to protect the devices from absorbing moisture during transportation and storage.

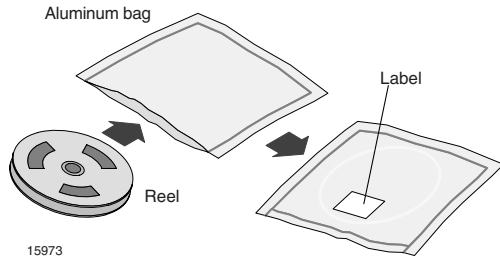

FINAL PACKING

The sealed reel is packed into a cardboard box. A secondary cardboard box is used for shipping purposes.

RECOMMENDED METHOD OF STORAGE

Dry box storage is recommended as soon as the aluminum bag has been opened to prevent moisture absorption. The following conditions should be observed, if dry boxes are not available:

- Storage temperature 10 °C to 30 °C
- Storage humidity ≤ 60 % RH max.

After more than 672 hours under these conditions moisture content will be too high for reflow soldering.

In case of moisture absorption, the devices will recover to the former condition by drying under the following condition:

192 hours at 40 °C + 5 °C/- 0 °C and < 5 % RH (dry air/nitrogen) or

96 hours at 60 °C + 5 °C and < 5 % RH for all device containers or

24 hours at 100 °C + 5 °C not suitable for reel or tubes.

An EIA JEDEC Standard JESD22-A112 Level 2a label is included on all dry bags.

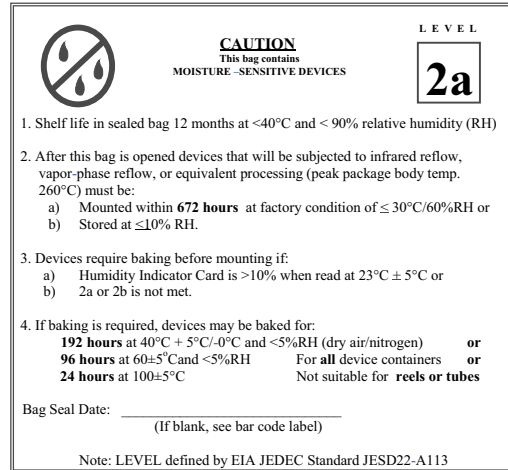

Example of JESD22-A112 Level 2a label

ESD PRECAUTION

Proper storage and handling procedures should be followed to prevent ESD damage to the devices especially when they are removed from the Antistatic Shielding Bag. Electro-Static Sensitive Devices warning labels are on the packaging.



OZONE DEPLETING SUBSTANCES POLICY STATEMENT

It is the policy of Vishay Semiconductor GmbH to

1. Meet all present and future national and international statutory requirements.
2. Regularly and continuously improve the performance of our products, processes, distribution and operating systems with respect to their impact on the health and safety of our employees and the public, as well as their impact on the environment.

It is particular concern to control or eliminate releases of those substances into the atmosphere which are known as ozone depleting substances (ODSs).

The Montreal Protocol (1987) and its London Amendments (1990) intend to severely restrict the use of ODSs and forbid their use within the next ten years. Various national and international initiatives are pressing for an earlier ban on these substances.

Vishay Semiconductor GmbH has been able to use its policy of continuous improvements to eliminate the use of ODSs listed in the following documents.

1. Annex A, B and list of transitional substances of the Montreal Protocol and the London Amendments respectively
2. Class I and II ozone depleting substances in the Clean Air Act Amendments of 1990 by the Environmental Protection Agency (EPA) in the USA
3. Council Decision 88/540/EEC and 91/690/EEC Annex A, B and C (transitional substances) respectively.

Vishay Semiconductor GmbH can certify that our semiconductors are not manufactured with ozone depleting substances and do not contain such substances.

We reserve the right to make changes to improve technical design and may do so without further notice.

Parameters can vary in different applications. All operating parameters must be validated for each customer application by the customer. Should the buyer use Vishay Semiconductors products for any unintended or unauthorized application, the buyer shall indemnify Vishay Semiconductors against all claims, costs, damages, and expenses, arising out of, directly or indirectly, any claim of personal damage, injury or death associated with such unintended or unauthorized use.

Vishay Semiconductor GmbH, P.O.B. 3535, D-74025 Heilbronn, Germany



Disclaimer

All product specifications and data are subject to change without notice.

Vishay Intertechnology, Inc., its affiliates, agents, and employees, and all persons acting on its or their behalf (collectively, "Vishay"), disclaim any and all liability for any errors, inaccuracies or incompleteness contained herein or in any other disclosure relating to any product.

Vishay disclaims any and all liability arising out of the use or application of any product described herein or of any information provided herein to the maximum extent permitted by law. The product specifications do not expand or otherwise modify Vishay's terms and conditions of purchase, including but not limited to the warranty expressed therein, which apply to these products.

No license, express or implied, by estoppel or otherwise, to any intellectual property rights is granted by this document or by any conduct of Vishay.

The products shown herein are not designed for use in medical, life-saving, or life-sustaining applications unless otherwise expressly indicated. Customers using or selling Vishay products not expressly indicated for use in such applications do so entirely at their own risk and agree to fully indemnify Vishay for any damages arising or resulting from such use or sale. Please contact authorized Vishay personnel to obtain written terms and conditions regarding products designed for such applications.

Product names and markings noted herein may be trademarks of their respective owners.