

VSC055

VITESSE

Enhanced I²C Backplane Controller



SPECIFICATIONS:

- ▶ 100-pin PQFP Package
- ▶ Two Clock Input Ranges: 8 to 10MHz (crystal) or 8.0 to 53.125MHz (Oscillator)

APPLICATIONS:

- ▶ Any Embedded Control Application Including:
 - SCSI and Fibre Channel JBODs or SBODs
 - Disk Arrays
 - RAID Subsystems
 - Servers
 - Telecommunication Equipment

FEATURES:

- ▶ Up to 64 Bits of 5 Volt Tolerant, User-definable, Bi-directional General Purpose I/O
- ▶ Slave mode I²C serial interface
- ▶ Integrated Port Bypass, Clock Recovery and Signal Detect Support for up to 16 Drive Ports
- ▶ Eight Programmable Fan Speed Monitoring Inputs
- ▶ Eight Programmable Pulse Width Modulated Fan Control Outputs
- ▶ Pairing of GPIO Pins for Direct Input/Output Signal Routing/Buffering
- ▶ Selectable Direct LED Drive Flashing Capability
- ▶ Pin-programmable Addressing for up to 16 Devices on a Single Serial Bus

VSC055 BLOCK DIAGRAM:

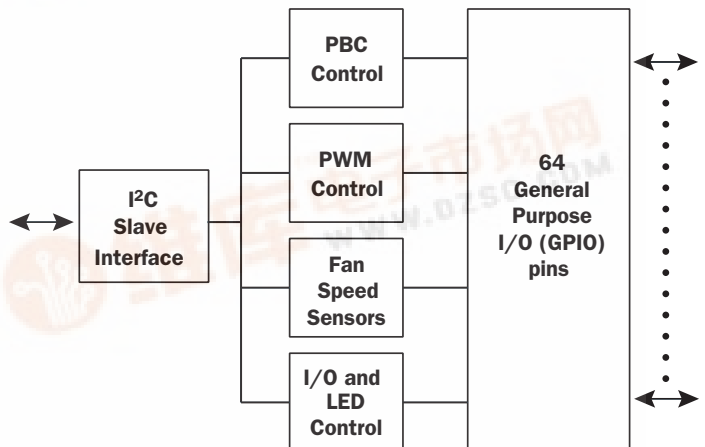

VSC055

Enhanced I²C Backplane Controller

GENERAL DESCRIPTION:



The VSC055 Enhanced I²C Backplane Controller is an integrated CMOS circuit that significantly reduces system cost by integrating all of the digital logic typically required to monitor a storage enclosure.

The VSC055 may be used in any embedded control application including parallel SCSI, Fibre Channel or any other application where the monitoring and control of a large number of digital I/O signals is required. Programming the VSC055 is easy through a

convenient programming model, which reduces the overall duration of the design-in cycle. Data is read from and written to the device over an addressable I²C serial interface, allowing multiple VSC055 devices on a single two-wire bus.

Furthermore, a key strength of the VSC055 is the ease in which it interoperates with Vitesse Fibre Channel port bypass circuits (PBC) and Enclosure Management Controllers, to provide a complete storage control chipset.

VSC055 APPLICATION DIAGRAM:

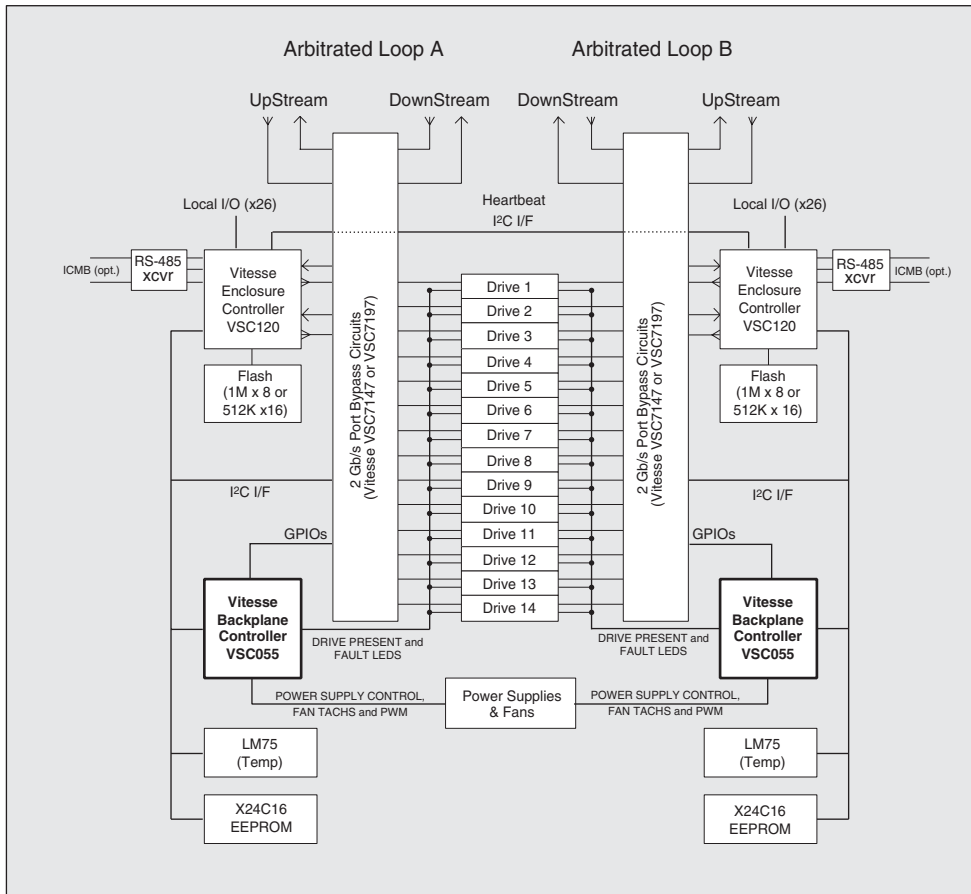

For more information on Vitesse Products visit the Vitesse web site at www.vitesse.com or contact Vitesse Sales at (800) VITESSE or sales@vitesse.com

VITESSE

741 Calle Plano
Camarillo, CA 93012, USA

Tel: +1 805.388.3700