



WJA1035

+5V Active-Bias InGaP HBT Gain Block

Product Features

- 50 – 4000 MHz
- 15 dB Gain
- +16 dBm P1dB
- +36 dBm OIP3
- +5V Single Voltage Supply
- Internal Active Bias Supply
- Internally matched to 50 Ω
- Lead-free / RoHS-compliant / Green SOT-89 package

Applications

- GSM, PCS, CDMA, WCDMA
- WiMAX, WiBro
- Repeaters, BTS Transceivers
- RFID

Product Description

The WJA1035 is a cascadable gain block that offers high linearity in a low-cost surface-mount package. At 1.9 GHz, the WJA1035 typically provides 15 dB gain, +36 dBm OIP3, and +16 dBm P1dB. The device is housed in a lead-free/green/RoHS-compliant SOT-89 industry-standard SMT package using a NiPdAu plating to eliminate the possibility of tin whiskering.

The WJA1035 consists of Darlington pair amplifiers using a high reliability InGaP/GaAs HBT process technology. The MMIC amplifier is internally matched to 50Ω and only requires DC-blocking capacitors and a bias inductor for operation. An internal active bias is designed to enable stable performance over temperature. A dropping bias resistor is not required allowing the device to be biased directly from a +5V supply voltage.

The broadband amplifier can be directly applied to various current and next generation wireless technologies such as GSM, CDMA, W-CDMA, WiBro, and WiMAX. The WJA1035 is ideal for general purpose applications such as LO buffering, IF amplification and pre-driver stages within the 50 to 4000 MHz frequency range.

Functional Diagram

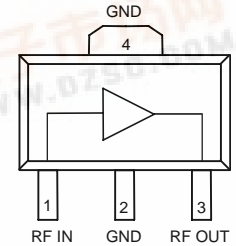

Function	Pin No.
Input	1
Output/Bias	3
Ground	2, 4

Specifications

Parameter	Units	Min	Typ	Max
Operational Bandwidth	MHz	50		4000
Test Frequency	MHz		1900	
Gain	dB		14.8	
Input Return Loss	dB		19	
Output Return Loss	dB		16	
Output P1dB	dBm		+16.1	
Output IP3 ⁽²⁾	dBm		+35.6	
Noise Figure	dB		6.2	
Device Voltage	V		5	
Device Current	mA		65	

1. Test conditions: 25 °C, Supply Voltage = +5.00 V, 50 Ω System.
2. 3OIP measured with two tones at an output power of 0 dBm/tone separated by 1 MHz. The suppression on the largest IM3 product is used to calculate the 3OIP using a 2:1 rule.
3. S-parameters and 3OIP measured at device pins. All other specifications measured on evaluation board.

Typical Performance

Parameter	Units	Typical			
Frequency	MHz	500	900	1900	2100
S21	dB	14.3	14.2	14	14
S11	dB	-14	-17	-19	-19
S22	dB	-19	-19	-10	-10
Output P1dB	dBm	+18.4	+17.6	+16.1	+15.5
Output IP3 ⁽²⁾	dBm	+36.9	+35.6	+34.6	+34.5
Noise Figure	dB	5.3	5.7	6.2	6.8

1. Listed typical performance parameters measured on evaluation board.

Absolute Maximum Rating

Parameter	Rating
Operating Case Temperature	-40 to +85 °C
Storage Temperature	-55 to +150 °C
Supply Voltage	+6.5 V
Input Power	+24 dBm

Operation of this device above any of these parameters may cause permanent damage.

Ordering Information

Part No.	Description
WJA1035	+5V Active Bias InGaP HBT Gain Block (lead-free/green/RoHS-compliant SOT-89 Package)
WJA1035-PCB	50 – 4000 MHz Fully Assembled Eval. Board



WJA1035

+5V Active-Bias InGaP HBT Gain Block

Typical Evaluation Board RF Performance

Supply Bias = +5.00 V, $I_{cc} = 65$ mA

1. Test conditions: $T = 25^\circ\text{C}$, Supply Voltage = +5.00 V, $I_{cc} = 65$ mA typical, 50 Ω System.
2. 3OIP measured with two tones at an output power of 0 dBm/tone separated by 1 MHz. The suppression on the largest IM3 product is used to calculate the 3OIP using a 2:1 rule.

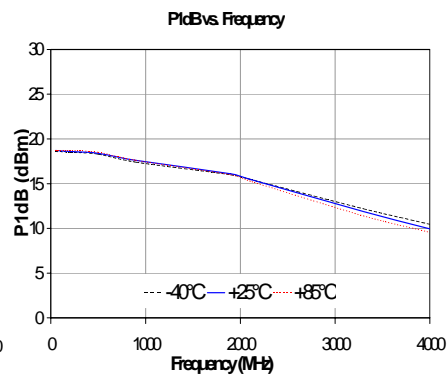
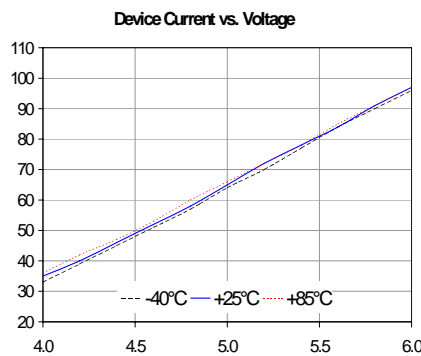
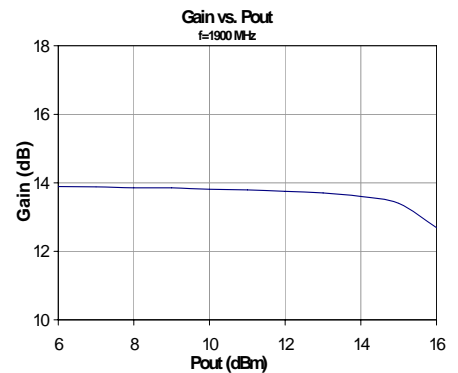
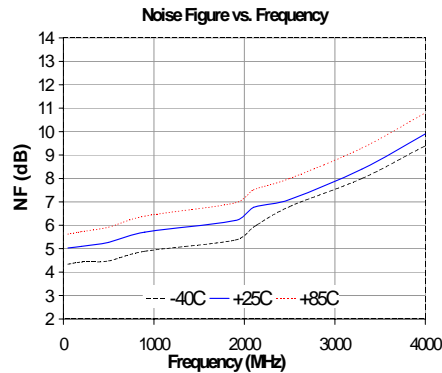
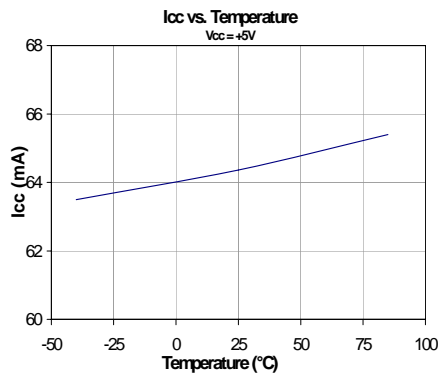
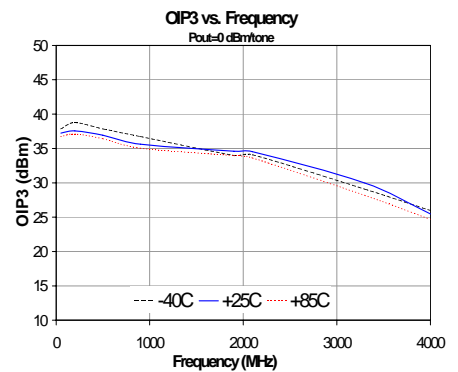
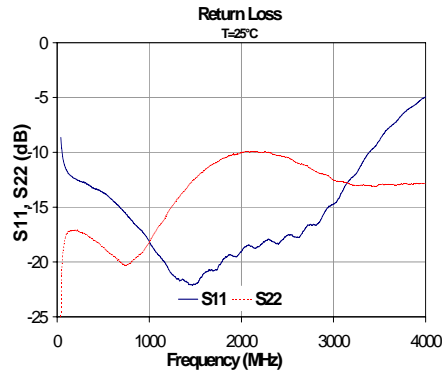
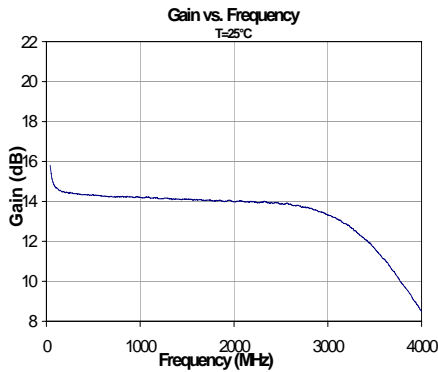



WJA1035

+5V Active-Bias InGaP HBT Gain Block

Application Circuit

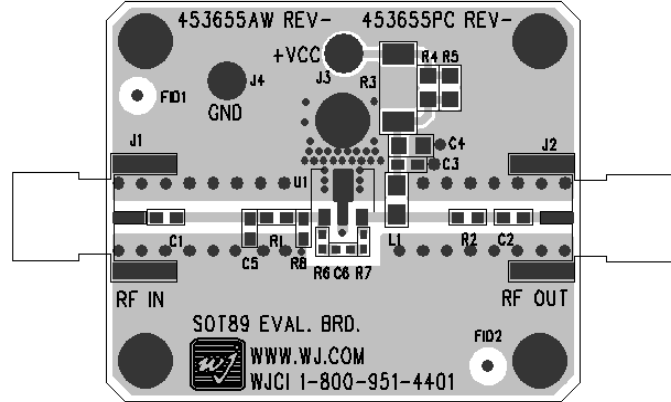
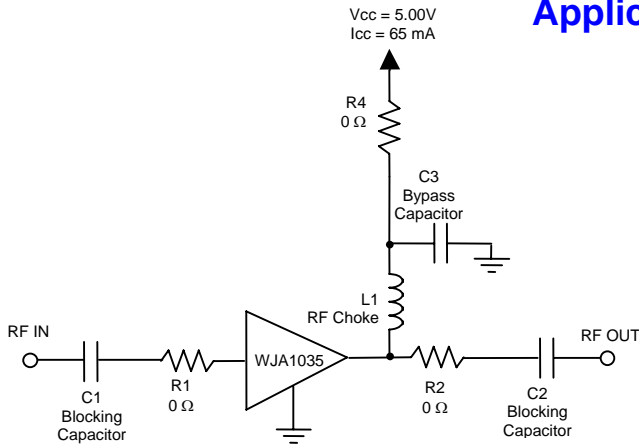

Recommended Component Values⁽¹⁾

Ref. Name	Value / Type	Size
L1	470 nH ferrite core wire wound inductor ⁽²⁾	0805
C1, C2	1000 pF NPO chip capacitor	0603
C3	0.018 μF chip capacitor	0603
R1, R2, R4	0 Ω ⁽³⁾	0603
C4, C5, C6, R3, R5, R6, R7, R8	Do Not Place ⁽³⁾	

1. The listed values are contained on the evaluation board to achieve optimal broadband performance
2. For lower cost and performance (500 – 4000 MHz) option use 18 nH air core wire wound inductor.
3. Place holders for the 0Ω resistors and “Do Not Place” references are not needed for final design.

Typical Device Data

S-Parameters ($V_{\text{device}} = +5.00 \text{ V}$, $I_{\text{CC}} = 64 \text{ mA}$, $T = 25 \text{ }^\circ\text{C}$, calibrated to device leads)

Freq (MHz)	S11 (dB)	S11 (ang)	S21 (dB)	S21 (ang)	S12 (dB)	S12 (ang)	S22 (dB)	S22 (ang)
10	-10.17	-62.05	19.42	162.82	-22.42	25.76	-6.92	-45.51
50	-12.26	-143.28	15.43	162.81	-19.09	8.25	-13.97	-117.48
100	-12.52	-162.17	14.83	166.27	-18.88	3.06	-15.94	-143.89
300	-12.54	-177.90	14.56	159.56	-18.78	-4.07	-17.23	-169.98
500	-12.50	177.96	14.56	148.45	-18.69	-8.32	-18.02	-178.40
700	-12.62	175.16	14.54	136.92	-18.76	-12.86	-18.75	178.73
900	-13.08	170.88	14.50	125.59	-18.64	-17.42	-19.49	-179.14
1100	-13.58	163.68	14.54	113.73	-18.59	-22.37	-19.55	-169.53
1300	-14.52	156.10	14.63	101.06	-18.50	-26.52	-18.79	-158.21
1500	-15.46	149.91	14.66	89.00	-18.49	-31.10	-17.99	-148.44
1700	-16.75	146.80	14.69	76.10	-18.35	-36.02	-16.95	-140.24
1900	-19.42	146.77	14.77	62.82	-18.31	-41.17	-15.71	-136.15
2100	-25.75	160.04	14.82	49.54	-18.30	-46.76	-13.77	-136.39
2300	-26.52	-105.22	14.67	35.08	-18.40	-52.76	-11.78	-142.64
2500	-17.99	-91.58	14.54	19.31	-18.45	-58.43	-9.93	-150.42
2700	-13.57	-98.92	14.26	4.52	-18.70	-64.51	-8.64	-157.92
2900	-10.56	-108.76	13.76	-10.36	-18.96	-70.20	-7.77	-166.68
3100	-8.37	-119.89	13.29	-26.30	-19.33	-75.81	-7.10	-177.36
3300	-6.60	-130.10	12.41	-40.96	-19.69	-80.92	-6.57	-170.51
3500	-5.39	-139.36	11.46	-54.49	-20.18	-84.47	-6.12	160.46
3700	-4.69	-149.24	10.43	-67.28	-20.55	-88.49	-5.88	152.12
3900	-4.14	-160.46	9.53	-79.14	-20.80	-91.02	-5.83	145.87
4100	-3.67	-171.17	8.50	-90.54	-20.98	-94.42	-5.94	138.78
4300	-3.13	-179.86	7.44	-101.60	-21.23	-97.85	-6.32	129.66
4500	-2.77	175.28	6.36	-111.29	-21.55	-100.66	-6.32	118.08



WJA1035

+5V Active-Bias InGaP HBT Gain Block

Mechanical Information

This package is lead-free/Green/RoHS-compliant. It is compatible with both lead-free (maximum 260 °C reflow temperature) and leaded (maximum 245 °C reflow temperature) soldering processes. The plating material on the leads is NiPdAu.

Outline Drawing

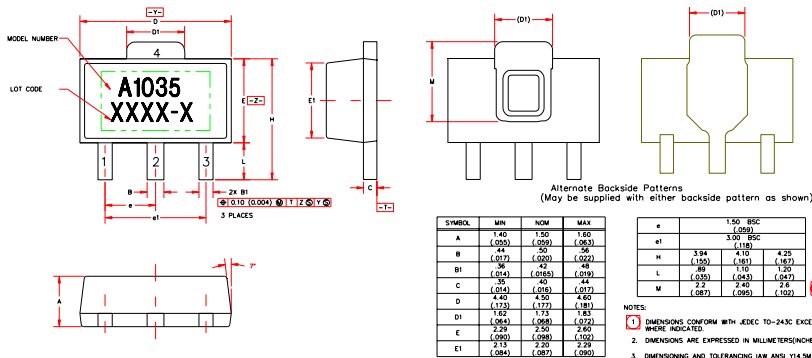

Product Marking

The WJA1035 will be marked with an "A1035" designator with an alphanumeric lot code marked below the part designator.

Tape and reel specifications for this part are located on the website in the "Application Notes" section.

MSL / ESD Rating



Caution! ESD sensitive device.

ESD Rating: Class 1C
 Value: Passes ≥ 1000V min.
 Test: Human Body Model (HBM)
 Standard: JEDEC Standard JESD22-A114

ESD Rating: Class IV
 Value: Passes ≥ 1000V min.
 Test: Charged Device Model (CDM)
 Standard: JEDEC Standard JESD22-C101

MSL Rating: Level 3 at +260 °C convection reflow
 Standard: JEDEC Standard J-STD-020

Land Pattern

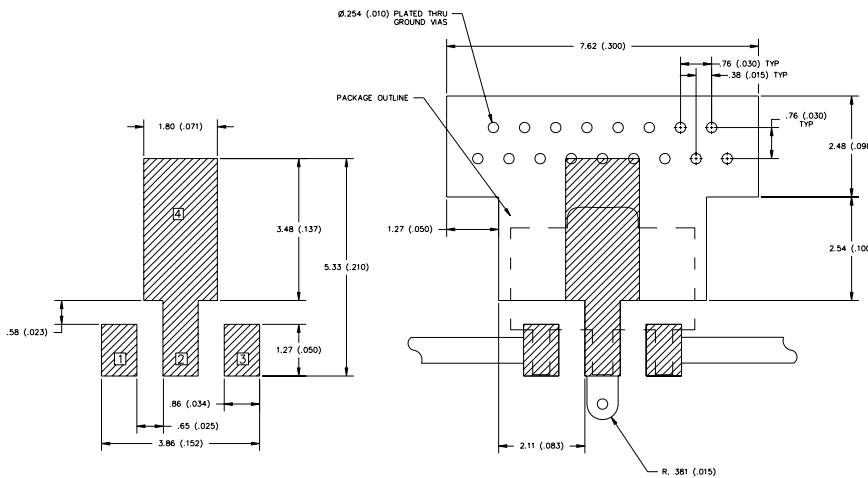

Mounting Config. Notes

1. Ground / thermal vias are critical for the proper performance of this device. Vias should use a .35mm (#80 / .0135") diameter drill and have a final plated thru diameter of .25 mm (.010").
2. Add as much copper as possible to inner and outer layers near the part to ensure optimal thermal performance.
3. Mounting screws can be added near the part to fasten the board to a heatsink. Ensure that the ground / thermal via region contacts the heatsink.
4. Do not put solder mask on the backside of the PC board in the region where the board contacts the heatsink.
5. RF trace width depends upon the PC board material and construction.
6. Use 1 oz. Copper minimum.
7. All dimensions are in millimeters (inches). Angles are in degrees.