



# WJA1510

+5V Active-Bias InGaP HBT Gain Block

## Product Features

- 50 – 1000 MHz
- 15 dB Gain
- +20 dBm P1dB
- +43 dBm OIP3
- +5V Single Voltage Supply
- Internal Active Bias Supply
- Internally matched to 50 Ω
- Lead-free / RoHS-compliant / Green SOT-89 package

## Applications

- IF Amplifier
- Repeaters, BTS Transceivers
- VHF/UHF
- Wireless Infrastructure
- General Purpose

## Product Description

The WJA1510 is a high performance amplifier that offers high linearity in a low-cost surface-mount package. At 200 MHz, the WJA1510 typically provides 15 dB gain, +43 dBm OIP3, and +20 dBm P1dB. The device is housed in a lead-free/green/RoHS-compliant SOT-89 industry-standard SMT package using a NiPdAu plating to eliminate the possibility of tin whiskering.

The WJA1510 consists of Darlington pair amplifiers using a high reliability InGaP/GaAs HBT process technology. The MMIC amplifier is internally matched to 50Ω and only requires DC-blocking capacitors and an inductive RF choke for operation. Biased directly from a 5V supply, an internal active bias network enables stable operation over temperature, eliminating the need for the typical dropping bias resistor.

The amplifier is targeted for high performance IF applications in existing and next generation wireless technologies. In addition, the WJA1510 will work for various other applications within the 50 to 1000 MHz frequency range.

## Functional Diagram

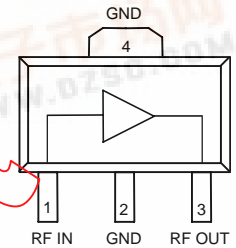

Function	Pin No.
Input	1
Output/Bias	3
Ground	2, 4

## Specifications

Parameter	Units	Min	Typ	Max
Operational Bandwidth	MHz	50		1000
Test Frequency	MHz		200	
Gain	dB		14.6	
Input Return Loss	dB		13	
Output Return Loss	dB		16	
Output P1dB	dBm		+20	
Output IP3 <sup>(2)</sup>	dBm		+43	
Noise Figure	dB		4.5	
Device Voltage	V		5	
Device Current	mA		97	

1. Test conditions: 25 °C, Supply Voltage = +5 V, 50 Ω System.  
 2. 3OIP measured with two tones at an output power of 0 dBm/tone separated by 1 MHz. The suppression on the largest IM3 product is used to calculate the 3OIP using a 2:1 rule.

## Typical Performance

Parameter	Units	Typical			
Frequency	MHz	50	100	200	500
S21	dB	15.5	15	14.6	14.3
S11	dB	-13	-13	-13	-12
S22	dB	-15	-16	-16	-14
Output P1dB	dBm	+20	+20	+20	+20
Output IP3 <sup>(2)</sup>	dBm	+44.5	+44.5	+43	+42
Noise Figure	dB	4.7	4.5	4.5	4.6

## Absolute Maximum Rating

Parameter	Rating
Operating Case Temperature	-40 to +85 °C
Storage Temperature	-55 to +150 °C

Operation of this device above any of these parameters may cause permanent damage.

## Ordering Information

Part No.	Description
WJA1510	+5V Active Bias InGaP HBT Gain Block (lead-free/green/RoHS-compliant SOT-89 Package)
WJA1510-PCB	50 – 1000 MHz Fully Assembled Eval. Board



# WJA1510

+5V Active-Bias InGaP HBT Gain Block

## Typical Device RF Performance

Supply Bias = +5 V,  $I_{cc} = 97$  mA

1. Test conditions:  $T = 25^\circ\text{C}$ , Supply Voltage = +5 V,  $I_{cc} = 97$  mA typical, 50  $\Omega$  System.
2. 3OIP measured with two tones at an output power of 0 dBm/tone separated by 1 MHz. The suppression on the largest IM3 product is used to calculate the 3OIP using a 2:1 rule.

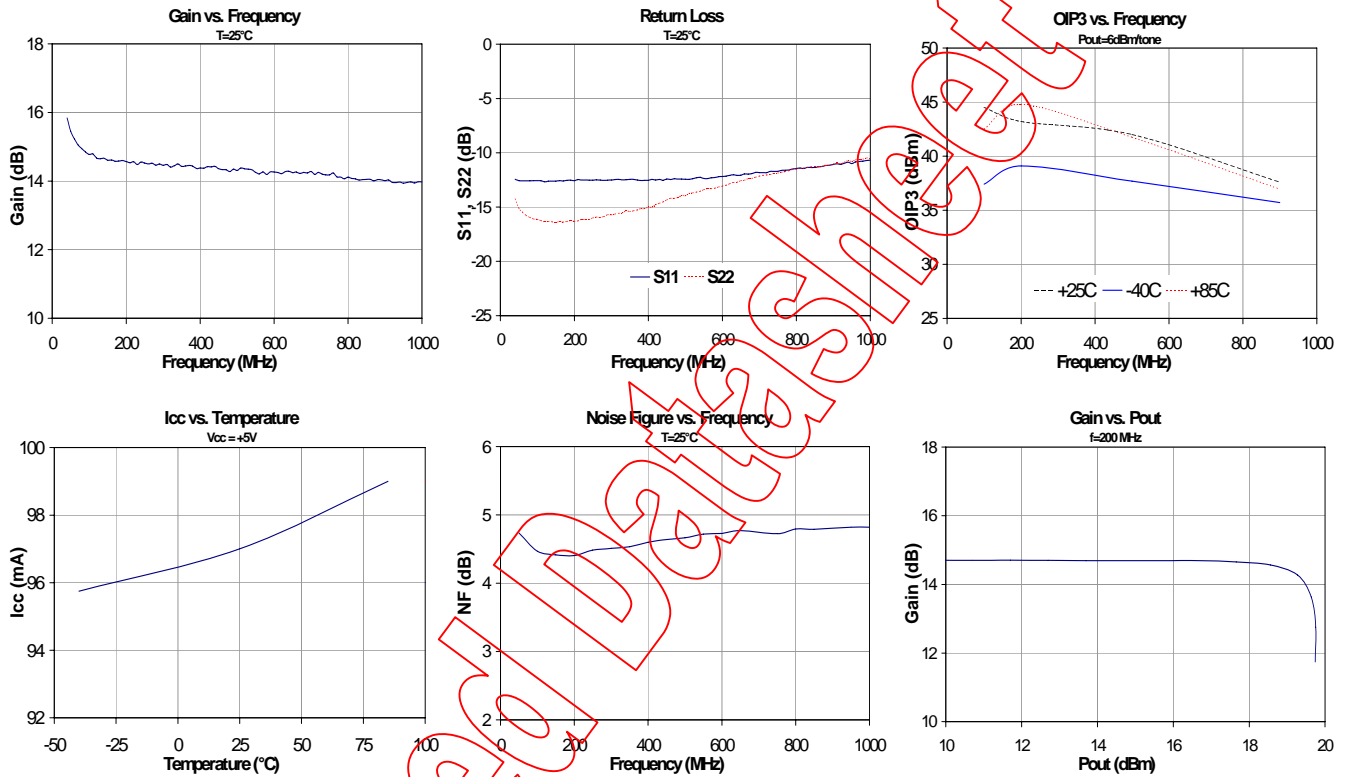

Advanced Data Sheet



# WJA1510

+5V Active-Bias InGaP HBT Gain Block

## Application Circuit

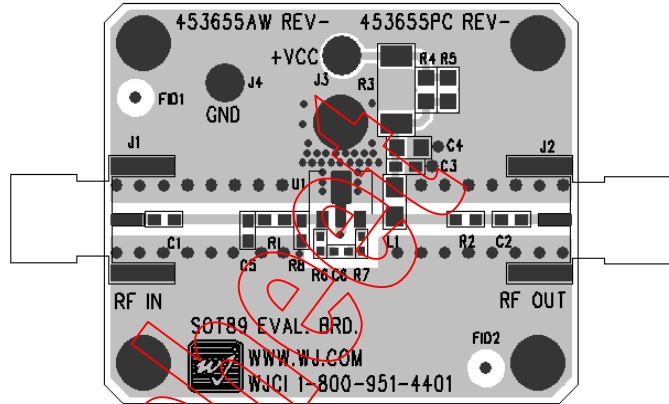
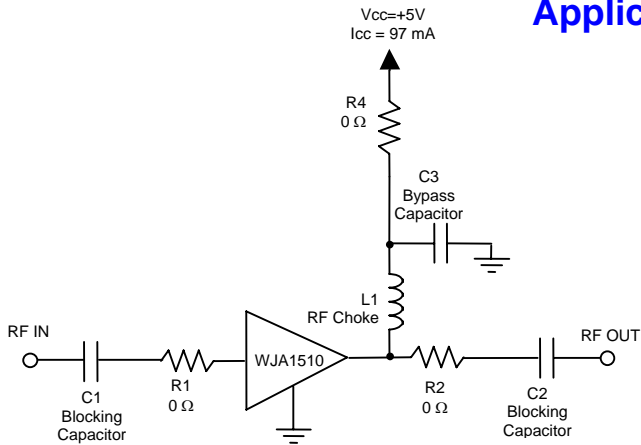

### Recommended Component Values<sup>(1)</sup>

Ref. Name	Value / Type	Size
L1	470 nH wire wound inductor	1008
C1, C2	1000 pF chip capacitor	0603
C3	0.018 μF chip capacitor	0603
R1, R2, R4	0 Ω <sup>(2)</sup>	0603
C4, C5, C6, R3, R5, R6, R7, R8	Do Not Place <sup>(2)</sup>	

- The listed values are contained on the evaluation board to achieve optimal broadband performance
- Place holders for the 0Ω resistors and "Do Not Place" references are not needed for final design.

## Typical Device Data

S-Parameters ( $V_{\text{device}} = +5 \text{ V}$ ,  $I_{\text{CC}} = 97 \text{ mA}$ ,  $T = 25^\circ \text{C}$ , calibrated to device leads)

Freq (MHz)	S11 (dB)	S11 (ang)	S21 (dB)	S21 (ang)	S12 (dB)	S12 (ang)	S22 (dB)	S22 (ang)
10	-12.35	-62.17	18.83	166.59	-22.08	19.62	-9.24	-43.23
50	-12.57	-143.37	13.45	164.24	-19.34	7.31	-15.09	-118.92
100	-12.57	-162.60	14.78	166.77	-19.10	2.87	-16.13	-141.93
150	-12.61	-169.29	14.61	166.15	-19.09	0.89	-16.43	-149.27
200	-12.57	-172.91	14.57	164.74	-19.07	-0.47	-16.32	-152.08
250	-12.52	-175.73	14.52	162.54	-19.02	-1.70	-16.00	-153.60
300	-12.51	-177.64	14.46	159.88	-19.05	-2.65	-15.72	-153.64
350	-12.45	-179.41	14.43	157.49	-19.00	-3.89	-15.40	-152.99
400	-12.53	-179.24	14.38	155.38	-19.00	-4.90	-15.00	-151.22
450	-12.41	-177.50	14.36	152.36	-18.98	-5.58	-14.34	-151.41
500	-12.44	-176.22	14.31	149.34	-18.92	-6.47	-13.97	-151.39
550	-12.37	-173.24	14.25	146.64	-18.94	-8.08	-13.40	-151.91
600	-12.17	-173.06	14.26	144.50	-18.92	-8.33	-13.07	-151.19
650	-12.06	-171.53	14.25	141.67	-18.93	-8.92	-12.58	-151.20
700	-11.83	-169.39	14.28	138.29	-18.81	-9.88	-12.15	-151.97
750	-11.71	-167.16	14.18	135.25	-18.81	-11.27	-11.87	-153.69
800	-11.45	-165.91	14.11	132.49	-18.84	-12.55	-11.50	-155.03
850	-11.35	-165.58	14.05	130.14	-18.85	-13.23	-11.28	-156.38
900	-11.07	-164.36	14.01	127.48	-18.81	-14.05	-11.06	-157.14
950	-10.99	-162.96	13.94	124.90	-18.74	-15.19	-10.79	-159.54
1000	-10.68	-160.93	13.97	121.72	-18.77	-16.24	-10.49	-161.27
1050	-10.42	-160.71	13.90	119.13	-18.79	-16.74	-10.24	-163.45
1100	-10.13	-158.88	13.86	115.96	-18.67	-17.66	-9.94	-166.39
1150	-10.06	-157.32	13.70	113.18	-18.67	-19.09	-9.78	-168.60
1200	-9.77	-155.75	13.72	110.90	-18.66	-20.05	-9.50	-170.96



# WJA1510

+5V Active-Bias InGaP HBT Gain Block

## Mechanical Information

This package is lead-free/Green/RoHS-compliant. It is compatible with both lead-free (maximum 260 °C reflow temperature) and leaded (maximum 245 °C reflow temperature) soldering processes. The plating material on the leads is NiPdAu.

### Outline Drawing

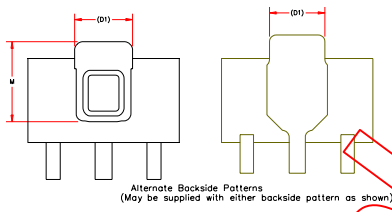
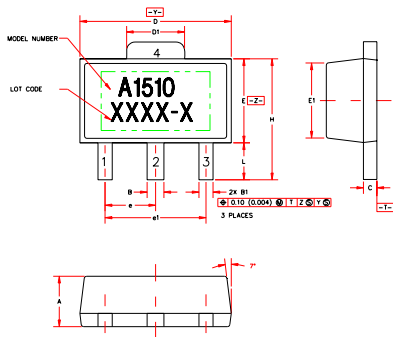

SYMBOL	MIN	NOM	MAX
A	1.42 (.055)	1.50 (.059)	1.60 (.063)
B	.44 (.017)	.50 (.020)	.56 (.022)
B1	.36 (.014)	.42 (.0165)	.48 (.019)
C	.42 (.016)	.45 (.018)	.48 (.019)
D	4.42 (.173)	4.50 (.177)	4.60 (.181)
D1	1.62 (.064)	1.75 (.069)	1.83 (.072)
E	2.28 (.090)	2.50 (.098)	2.60 (.102)
E1	2.13 (.084)	2.20 (.087)	2.28 (.090)

#	1.50 BSC (.059)	3.00 BSC (.118)	4.25 BSC (.167)
e1	3.84 (.151)	4.10 (.161)	4.25 (.167)
H	.80 (.031)	1.10 (.043)	1.20 (.047)
L	.22 (.009)	.24 (.009)	.26 (.010)
M	.28 (.011)	.28 (.011)	.28 (.011)

NOTES:  
 1. DIMENSIONS CONFORM WITH JEDEC TO-263C EXCEPT WHERE INDICATED.  
 2. DIMENSIONS ARE EXPRESSED IN MILLIMETERS (INCHES).  
 3. DIMENSIONING AND TOLERANCING ARE ANS Y14.5M

### Product Marking

The WJA1510 will be marked with an "A1510" designator with an alphanumeric lot code marked below the part designator.

Tape and reel specifications for this part are located on the website in the "Application Notes" section.

### MSL / ESD Rating



Caution! ESD sensitive device.

ESD Rating: Class 1C  
 Value: Passes ≥ 1000V min.  
 Test: Human Body Model (HBM)  
 Standard: JEDEC Standard JESD22-A114

ESD Rating: Class IV  
 Value: Passes ≥ 1000V min.  
 Test: Charged Device Model (CDM)  
 Standard: JEDEC Standard JESD22-C101

### Land Pattern

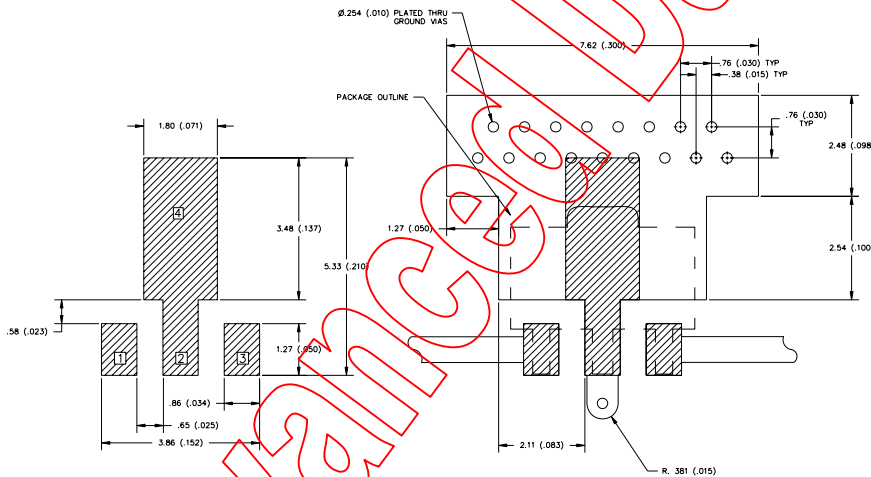

### Mounting Config. Notes

1. Ground / thermal vias are critical for the proper performance of this device. Vias should use a .35mm (#80 / .0135") diameter drill and have a final plated thru diameter of .25 mm (.010").
2. Add as much copper as possible to inner and outer layers near the part to ensure optimal thermal performance.
3. Mounting screws can be added near the part to fasten the board to a heatsink. Ensure that the ground / thermal via region contacts the heatsink.
4. Do not put solder mask on the backside of the PC board in the region where the board contacts the heatsink.
5. RF trace width depends upon the PC board material and construction.
6. Use 1 oz. Copper minimum.
7. All dimensions are in millimeters (inches). Angles are in degrees.

Advanced Data