



# WM8781

## 24-Bit, 192kHz Stereo ADC

### DESCRIPTION

The WM8781 is a high performance, low cost stereo audio ADC designed for recordable media applications.

The device offers stereo line level inputs along with two control input pins (FORMAT, IWL) to allow operation of the audio interface in three industry standard modes. An internal op-amp is integrated on the front end of the chip to accommodate analogue input signals greater than  $1V_{rms}$ . The device also has a high pass filter to remove residual DC offsets.

WM8781 offers Master or Slave mode clocking schemes. A control input pin M/S is used to allow Slave mode operation or Master mode operation. A stereo 24-bit multi-bit sigma-delta ADC is used with 128x, 64x or 32x over-sampling, according to sample rate. Digital audio output word lengths from 16-24 bits and sampling rates from 8kHz to 192kHz are supported.

The device is a hardware controlled device and is supplied in a 20-lead SSOP package.

### FEATURES

- SNR 102dB ('A' weighted @ 48kHz)
- THD -90dB (at -1dB)
- Sampling Frequency: 8 – 192kHz
- Master or Slave Clocking Mode
- System Clock (MCLK): 128fs, 192fs, 256fs, 384fs, 512fs, 768fs
- Audio Data Interface Modes
  - 16-24 bit I<sup>2</sup>S, 16-24 bit Left, 16-24 bit Right Justified
- Supply Voltages
  - Analogue 2.7 to 5.5V
  - Digital core: 2.7V to 3.6V
- 20-lead SSOP package

### APPLICATIONS

- Recordable DVD Players
- Personal Video Recorders
- STB
- Studio Audio Processing Equipment

### BLOCK DIAGRAM

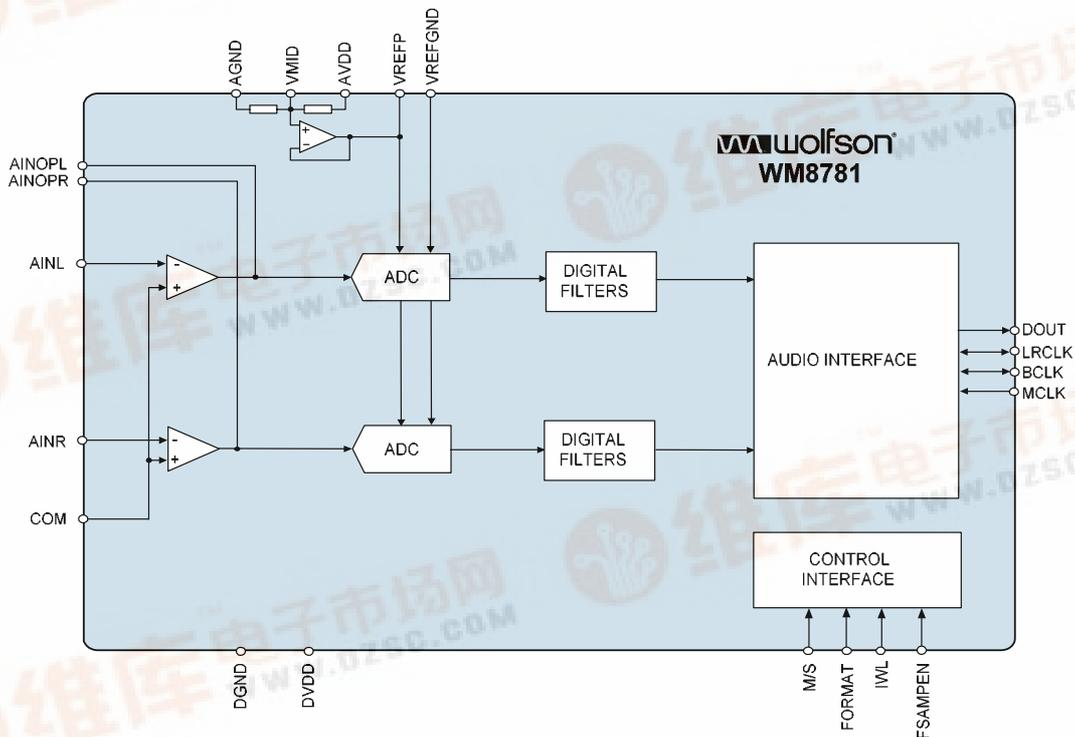

## TABLE OF CONTENTS

<b>DESCRIPTION .....</b>	<b>1</b>
<b>FEATURES.....</b>	<b>1</b>
<b>APPLICATIONS .....</b>	<b>1</b>
<b>BLOCK DIAGRAM .....</b>	<b>1</b>
<b>TABLE OF CONTENTS .....</b>	<b>2</b>
<b>PIN CONFIGURATION.....</b>	<b>3</b>
<b>ORDERING INFORMATION .....</b>	<b>3</b>
<b>ABSOLUTE MAXIMUM RATINGS .....</b>	<b>5</b>
<b>RECOMMENDED OPERATING CONDITIONS .....</b>	<b>5</b>
<b>ELECTRICAL CHARACTERISTICS .....</b>	<b>6</b>
TERMINOLOGY.....	7
<b>SIGNAL TIMING REQUIREMENTS .....</b>	<b>8</b>
<b>DEVICE DESCRIPTION .....</b>	<b>10</b>
INTRODUCTION.....	10
ADC .....	10
ADC DIGITAL FILTER .....	10
DIGITAL AUDIO INTERFACE.....	11
POWER DOWN CONTROL.....	14
POWER ON RESET .....	14
<b>DIGITAL FILTER CHARACTERISTICS .....</b>	<b>16</b>
ADC FILTER RESPONSES .....	16
ADC HIGH PASS FILTER.....	17
<b>APPLICATIONS INFORMATION .....</b>	<b>18</b>
RECOMMENDED EXTERNAL COMPONENTS.....	18
RECOMMENDED EXTERNAL COMPONENTS VALUES.....	18
<b>PACKAGE DIMENSIONS .....</b>	<b>19</b>
<b>IMPORTANT NOTICE .....</b>	<b>20</b>
ADDRESS:.....	20

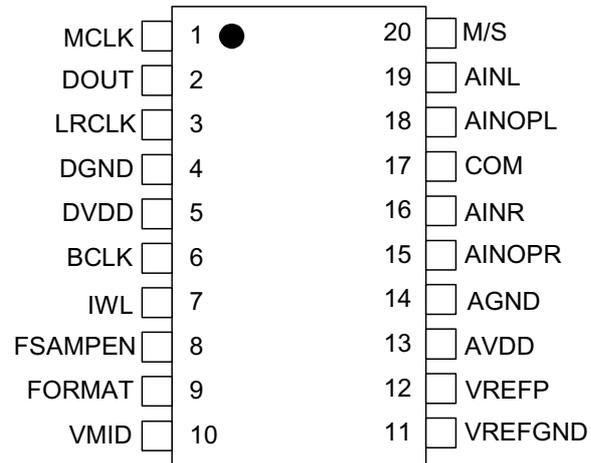
**PIN CONFIGURATION****ORDERING INFORMATION**

DEVICE	TEMPERATURE RANGE	PACKAGE	MOISTURE SENSITIVITY LEVEL	PEAK SOLDERING TEMPERATURE
WM8781GEDS	-25°C to +85°C	20-lead SSOP (Pb-free)	MSL1	260°C
WM8781GEDS/R	-25°C to +85°C	20-lead SSOP (Pb-free, tape and reel)	MSL1	260°C

**Note:**

Reel quantity = 2,000

**PIN DESCRIPTION**

PIN NO.	NAME	TYPE	DESCRIPTION
1	MCLK	Digital Input	Master Clock
2	DOUT	Digital Output	ADC Digital Audio Data
3	LRCLK	Digital Input / Output	Audio Interface Left / Right Clock
4	DGND	Supply	Digital Negative Supply
5	DVDD	Supply	Digital Positive Supply
6	BCLK	Digital Input / Output	Audio Interface Bit Clock
7	IWL	Digital Tristate Input	Word Length 0 = 16 bit 1 = 20 bit Z = 24 bit
8	FSAMPEN	Digital Tristate Input	Fast Sampling Rate Enable 0 = 48kHz enable 1 = 96kHz enable Z = 192kHz enable
9	FORMAT	Digital Tristate Input	Audio Mode Select 0 = RJ 1 = LJ Z = I2S
10	VMID	Analogue Output	Midrail Voltage Decoupling Capacitor
11	VREFGND	Supply	Negative Supply and Substrate Connection
12	VREFP	Analogue Output	Positive Reference Voltage Decoupling Pin; 10uF external decoupling
13	AVDD	Supply	Analogue Positive Supply
14	AGND	Supply	Analogue Negative Supply and Substrate Connection
15	AINOPR	Analogue Output	Right Channel Internal Op-Amp Output
16	AINR	Analogue Input	Right Channel Input
17	COM	Analogue Input	Common mode high impedance input should be set to midrail.
18	AINOPL	Analogue Output	Left Channel Internal Op-Amp Output
19	AINL	Analogue Input	Left Channel Input
20	M/S	Digital Input	Interface Mode Select 0 = Slave mode (128fs, 192fs, 256fs, 384fs, 512fs, 768fs) 1 = Master mode (384fs, 192fs) (fs=word clock frequency)

## ABSOLUTE MAXIMUM RATINGS

Absolute Maximum Ratings are stress ratings only. Permanent damage to the device may be caused by continuously operating at or beyond these limits. Device functional operating limits and guaranteed performance specifications are given under Electrical Characteristics at the test conditions specified.



ESD Sensitive Device. This device is manufactured on a CMOS process. It is therefore generically susceptible to damage from excessive static voltages. Proper ESD precautions must be taken during handling and storage of this device.

Wolfson tests its package types according to IPC/JEDEC J-STD-020B for Moisture Sensitivity to determine acceptable storage conditions prior to surface mount assembly. These levels are:

MSL1 = unlimited floor life at <30°C / 85% Relative Humidity. Not normally stored in moisture barrier bag.

MSL2 = out of bag storage for 1 year at <30°C / 60% Relative Humidity. Supplied in moisture barrier bag.

MSL3 = out of bag storage for 168 hours at <30°C / 60% Relative Humidity. Supplied in moisture barrier bag.

The Moisture Sensitivity Level for each package type is specified in Ordering Information.

CONDITION	MIN	MAX
Digital supply voltage	-0.3V	+3.63V
Analogue supply voltage	-0.3V	+7V
Voltage range digital inputs	DGND -0.3V	DVDD + 0.3V
Voltage range analogue inputs	AGND -0.3V	AVDD +0.3V
+Operating temperature range, T <sub>A</sub>	-25°C	+85°C
Storage temperature after soldering	-65°C	+150°C

### Notes

- Analogue and digital grounds must always be within 0.3V of each other.

## RECOMMENDED OPERATING CONDITIONS

PARAMETER	SYMBOL	TEST CONDITIONS	MIN	TYP	MAX	UNIT
Digital supply range	DVDD		2.7		3.6	V
Analogue supply range	AVDD		2.7		5.5	V
Ground	DGND,AGND			0		V

### Notes

- Digital supply DVDD must never be more than 0.3V greater than AVDD.

## ELECTRICAL CHARACTERISTICS

### Test Conditions

DVDD = 3.3V, AVDD = 5.0V, TA = +25°C, 1kHz signal, A-weighted, fs = 48kHz, MCLK = 256fs, 24-bit audio data, Slave Mode unless otherwise stated.

PARAMETER	SYMBOL	TEST CONDITIONS	MIN	TYP	MAX	UNIT
<b>ADC Performance</b>						
Full Scale Input Signal Level (for ADC 0dB Input)				1.0		V <sub>rms</sub>
Input resistance, using recommended external resistor network on p17.				10		kΩ
Input capacitance				20		pF
Signal to Noise Ratio (see Terminology note 1,2,4)	SNR	A-weighted, @ fs = 48kHz	93	102		dB
		Unweighted, @ fs = 48kHz		100		dB
		A-weighted, @ fs = 48kHz, AVDD = 3.3V		100		dB
Signal to Noise Ratio (see Terminology note 1,2,4)	SNR	A-weighted, @ fs = 96kHz	93	99		dB
		Unweighted, @ fs = 96kHz		99		dB
		A-weighted, @ fs = 96kHz, AVDD = 3.3V		99		dB
Total Harmonic Distortion	THD	1kHz, -1dB Full Scale @ fs = 48kHz		-91		dB
		1kHz, -1dB Full Scale @ fs = 96kHz		-91		dB
		1kHz, -1dB Full Scale @ fs = 192kHz		-90		dB
Dynamic Range	DNR	-60dBFS	93	102		dB
Channel Separation (see Terminology note 4)		1kHz Input		90		dB
Channel Level Matching		1kHz signal		0.1		dB
Channel Phase Deviation		1kHz signal		0.0001		Degree
Power Supply Rejection Ratio	PSRR	1kHz 100mVpp, applied to AVDD, DVDD		50		dB
<b>Digital Logic Levels (TTL Levels)</b>						
Input LOW level	V <sub>IL</sub>				0.8	V
Input HIGH level	V <sub>IH</sub>		2.0			V
Input leakage current – digital pad			-1	±0.2	+1	μA
Input leakage current – digital tristate input (Note 3)				85		μA
Input capacitance				5		pF
Output LOW	V <sub>OL</sub>	I <sub>OL</sub> =1mA			0.1 x DVDD	V
Output HIGH	V <sub>OH</sub>	I <sub>OH</sub> = -1mA	0.9 x DVDD			V

**Test Conditions**

DVDD = 3.3V, AVDD = 5.0V, TA = +25°C, 1kHz signal, A-weighted, fs = 48kHz, MCLK = 256fs, 24-bit audio data, Slave Mode unless otherwise stated.

PARAMETER	SYMBOL	TEST CONDITIONS	MIN	TYP	MAX	UNIT
<b>Analogue Reference Levels</b>						
Midrail Reference Voltage	VMID	AVDD to VMID and VMID to VREFN	-3%	AVDD/2	+3%	V
Potential Divider Resistance	R <sub>VMID</sub>			50		kΩ
Buffered Reference Voltage	VREFP		-3%	AVDD/2	+3%	V
VREF source current	I <sub>VREF</sub>				5	mA
VREF sink current	I <sub>VREF</sub>				5	mA
<b>Supply Current</b>						
Analogue supply current		AVDD = 5V		32		mA
Digital supply current		DVDD = 3.3V		5		mA
Power Down				0.5		mA

**Notes:**

1. All performance measurements are done with a 20kHz low pass filter, and where noted an A-weight filter. Failure to use such a filter will result in higher THD+N and lower SNR and Dynamic Range readings than are found in the Electrical Characteristics. The low pass filter removes out of band noise; although this is not audible, it may affect dynamic specification values.
2. VMID is decoupled with 10uF and 0.1uF capacitors close to the device package. Smaller capacitors may reduce performance.
3. This high leakage current is due to the topology of the instate pads. The pad input is connected to the midpoint of an internal resistor string to pull input to vmid if undriven.

**TERMINOLOGY**

1. Signal-to-noise ratio (dB) – Ratio of output level with 1kHz full scale input, to the output level with all zeros into the digital input, over a 20Hz to 20kHz bandwidth. (No Auto-zero or Automute function is employed in achieving these results).
2. Dynamic range (dB) – DR is a measure of the difference between the highest and lowest portions of a signal. Normally a THD+N measurement at 60dB below full scale. The measured signal is then corrected by adding the 60dB to it. (e.g. THD+N @ -60dB= -32dB, DR= 92dB).
3. THD+N (dB) – THD+N is a ratio, of the rms values, of (Noise + Distortion)/Signal.
4. Channel Separation (dB) – Also known as Cross-Talk. This is a measure of the amount one channel is isolated from the other. Normally measured by sending a full scale signal down one channel and measuring the other.

## SIGNAL TIMING REQUIREMENTS

### SYSTEM CLOCK TIMING

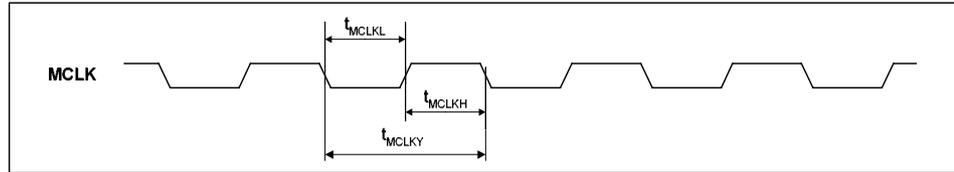

Figure 1 System Clock Timing Requirements

**Test Conditions**

DVDD = 3.3V, DGND = 0V, T<sub>A</sub> = +25°C.

PARAMETER	SYMBOL	MIN	TYP	MAX	UNIT
<b>System Clock Timing Information</b>					
MCLK System clock pulse width high	T <sub>MCLKL</sub>	11			ns
MCLK System clock pulse width low	T <sub>MCLKH</sub>	11			ns
MCLK System clock cycle time	T <sub>MCLKY</sub>	28			ns
MCLK duty cycle	T <sub>MCLKDS</sub>	40:60		60:40	

Table 1 Master Clock Timing Requirements

### AUDIO INTERFACE TIMING – MASTER MODE

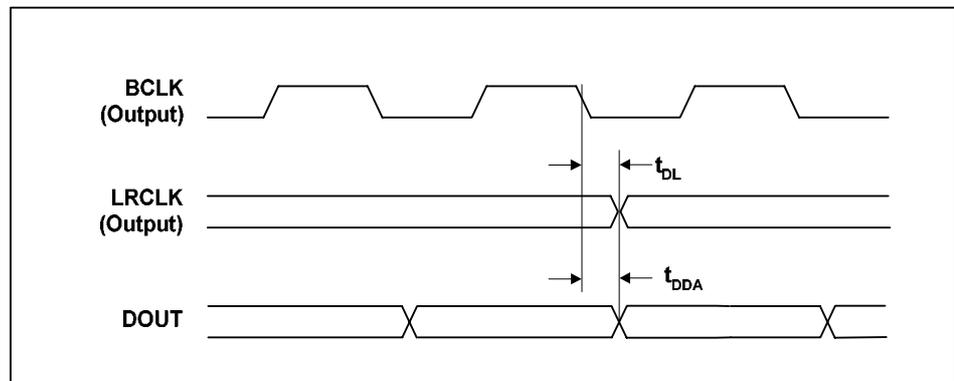

Figure 2 Digital Audio Data Timing – Master Mode (see Control Interface)

**Test Conditions**

DVDD = 3.3V, DGND = 0V, T<sub>A</sub> = +25°C, Master Mode, fs = 48kHz, MCLK = 384fs, 24-bit data, unless otherwise stated.

PARAMETER	SYMBOL	MIN	TYP	MAX	UNIT
<b>Audio Data Input Timing Information</b>					
LRCLK propagation delay from BCLK falling edge	t <sub>DL</sub>	0		10	ns
DOUT propagation delay from BCLK falling edge	t <sub>DDA</sub>	0		10	ns

Table 2 Digital Audio Data Timing - Master Mode

**AUDIO INTERFACE TIMING – SLAVE MODE**

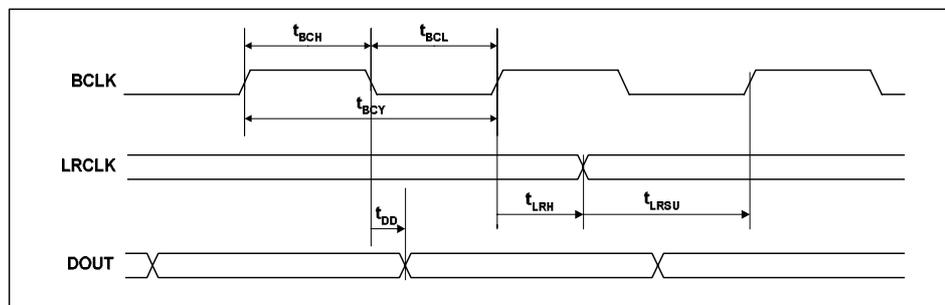

**Figure 3 Digital Audio Data Timing – Slave Mode**

**Test Conditions**

DVDD = 3.3V, DGND = 0V, T<sub>A</sub> = +25°C, Slave Mode, fs = 48kHz, MCLK = 256fs, 24-bit data, unless otherwise stated.

PARAMETER	SYMBOL	MIN	TYP	MAX	UNIT
<b>Audio Data Input Timing Information</b>					
BCLK cycle time	t <sub>BCY</sub>	50			ns
BCLK pulse width high	t <sub>BCH</sub>	20			ns
BCLK pulse width low	t <sub>BCL</sub>	20			ns
LRCLK set-up time to BCLK rising edge	t <sub>LRSU</sub>	10			ns
LRCLK hold time from BCLK rising edge	t <sub>LRH</sub>	10			ns
DOUT propagation delay from BCLK falling edge	t <sub>DD</sub>	0		10	ns

**Table 3 Digital Audio Data Timing - Slave Mode**

**Note:**

LRCLK should be synchronous with MCLK, although the WM8781 interface is tolerant of phase variations or jitter on these signals.

## DEVICE DESCRIPTION

### INTRODUCTION

The WM8781 is a stereo 24-bit ADC designed for demanding recording applications such as DVD recorders, studio mixers, PVRs, and AV amplifiers. The WM8781 consists of stereo line level inputs, followed by a sigma-delta modulator and digital filtering.

The device offers stereo line level inputs along with two control input pins (FORMAT, IWL) to allow operation of the audio interface in three industry standard modes (left justified, right justified or I<sup>2</sup>S). An internal op-amp is integrated on the front end of the chip to accommodate analogue input signals greater than 1V<sub>rms</sub>. The device also has a high pass filter to remove residual DC offsets.

The WM8781 offers Master or Slave mode clocking schemes. A control input pin M/S is used to allow Slave mode or Master mode operation. The WM8781 supports master clock rates from 128fs to 768fs and digital audio output word lengths from 16-24 bits. Sampling rates from 8kHz to 192kHz are supported, delivering high SNR operating with 128x, 64x or 32x over-sampling, according to the sample rate.

The line inputs are biased internally through the operational amplifier to V<sub>MID</sub>.

### ADC

The WM8781 uses a multi-bit over sampled sigma-delta ADC. A single channel of the ADC is illustrated in Figure 4 Multi-Bit Oversampling Sigma Delta ADC Schematic.

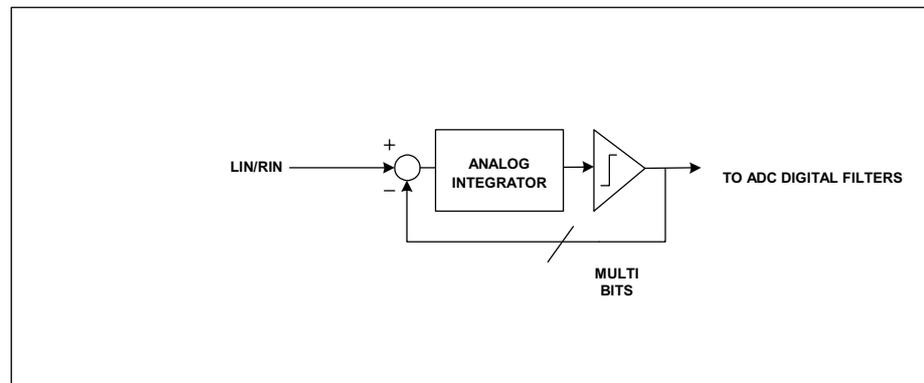

**Figure 4 Multi-Bit Oversampling Sigma Delta ADC Schematic**

The use of multi-bit feedback and high oversampling rates reduces the effects of jitter and high frequency noise.

The ADC Full Scale input is 1.0V rms at AVDD = 5.0 volts. Any input voltage greater than full scale will possibly overload the ADC and cause distortion. Note that the full scale input has a linear relationship with AVDD. The internal op-amp and appropriate resistors can be used to reduce signals greater than 1Vrms before they reach the ADC.

The ADC filters perform true 24 bit signal processing to convert the raw multi-bit oversampled data from the ADC to the correct sampling frequency to be output on the digital audio interface.

### ADC DIGITAL FILTER

The ADC digital filters contain a digital high pass filter. The high-pass filter response detailed in Digital Filter Characteristics. The operation of the high pass filter removes residual DC offsets that are present on the audio signal.

## DIGITAL AUDIO INTERFACE

The digital audio interface uses three pins:

- DOUT: ADC data output
- LRCLK: ADC data alignment clock
- BCLK: Bit clock, for synchronisation

The digital audio interface takes the data from the internal ADC digital filters and places it on DOUT and LRCLK. DOUT is the formatted digital audio data stream output from the ADC digital filters with left and right channels multiplexed together. LRCLK is an alignment clock that controls whether Left or Right channel data is present on the DOUT line. DOUT and LRCLK are synchronous with the BCLK signal with each data bit transition signified by a BCLK high to low transition. DOUT is always an output. BCLK and LRCLK maybe an inputs or outputs depending whether the device is in Master or Slave mode. (see Master and Slave Mode Operation, below).

Three different audio data formats are supported:

- Left justified
- Right justified
- I<sup>2</sup>S

### MASTER AND SLAVE MODE OPERATION

The WM8781 can be configured as either a master or slave mode device. As a master device the WM8781 generates BCLK and LRCLK and thus controls sequencing of the data transfer on DOUT. In slave mode, the WM8781 responds with data to clocks it receives over the digital audio interface. The mode can be selected by setting the MS input pin (see Table 4 Master/Slave selection below). Master and slave modes are illustrated below.

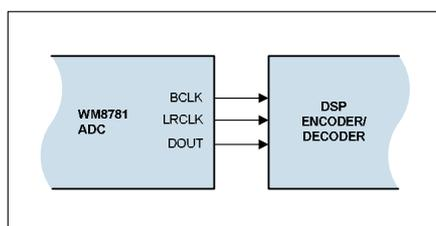

Figure 5 Master Mode

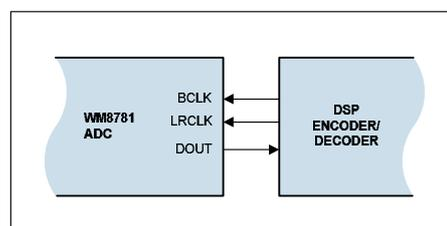

Figure 6 Slave Mode

PIN	DESCRIPTION
M/S	Master/Slave Selection 0 = Slave Mode 1 = Master Mode

Table 4 Master/Slave selection

### AUDIO INTERFACE CONTROL

The Input Word Length and Audio Format mode can be selected by using IWL and FORMAT pins.

PIN	DESCRIPTION
IWL	Word Length 0 = 16 bit 1 = 20 bit Z = 24 bit
FORMAT	Audio Mode Select 0 = RJ 1 = LJ Z = I2S

Table 5 Audio Data Format Control

**AUDIO DATA FORMATS**

In Left Justified mode, the MSB is available on the first rising edge of BCLK following an LRCLK transition. The other bits up to the LSB are then transmitted in order. Depending on word length, BCLK frequency and sample rate, there may be unused BCLK cycles before each LRCLK transition.

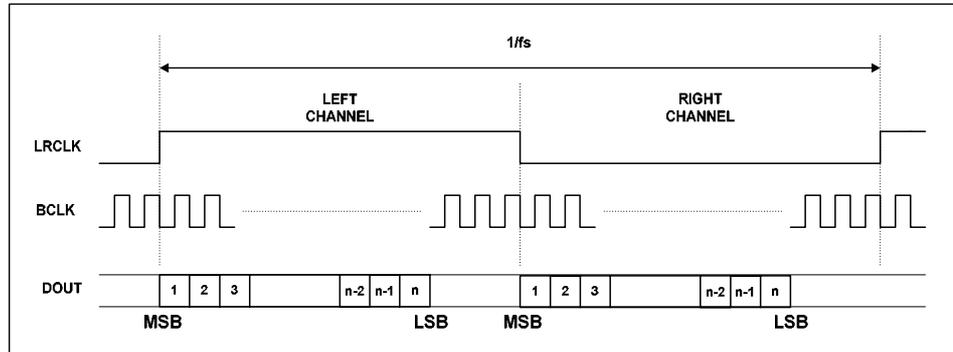

**Figure 7 Left Justified Audio Interface (assuming n-bit word length)**

In Right Justified mode, the LSB is available on the last rising edge of BCLK before an LRCLK transition. All other bits are transmitted before (MSB first). Depending on word length, BCLK frequency and sample rate, there may be unused BCLK cycles after each LRCLK transition.

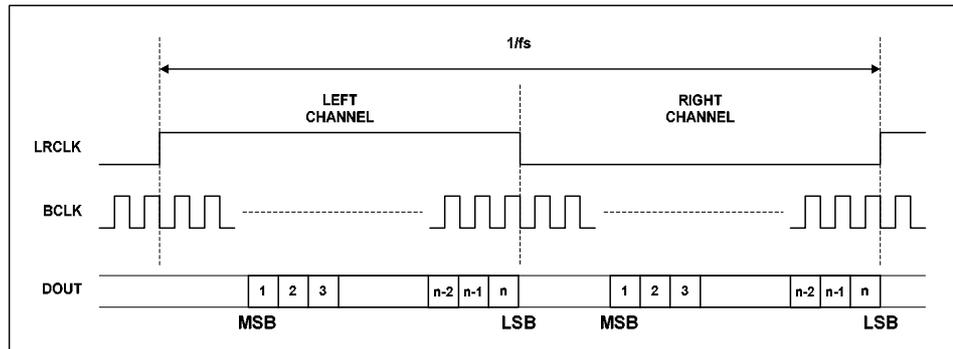

**Figure 8 Right Justified Audio Interface (assuming n-bit word length)**

In I<sup>2</sup>S mode, the MSB is available on the second rising edge of BCLK following an LRCLK transition. The other bits up to the LSB are then transmitted in order. Depending on word length, BCLK frequency and sample rate, there may be unused BCLK cycles between the LSB of one sample and the MSB of the next.

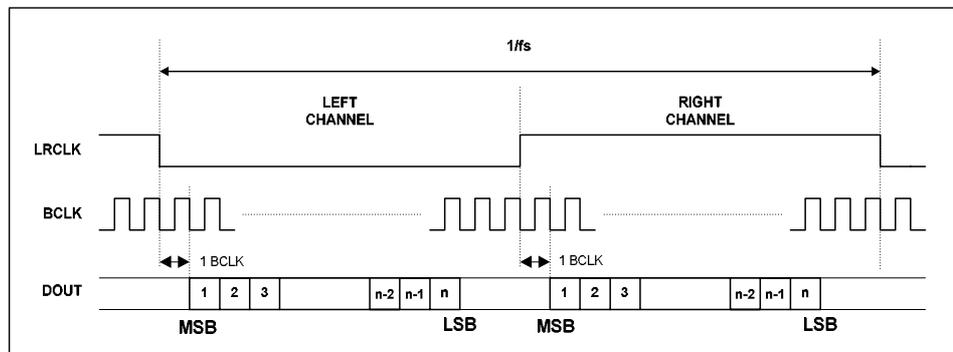

**Figure 9 I<sup>2</sup>S Audio Interface (assuming n-bit word length)**

### MASTER CLOCK AND AUDIO SAMPLE RATES

In a typical digital audio system there is only one central clock source producing a reference clock to which all audio data processing is synchronised. This clock is often referred to as the audio system's Master Clock (MCLK). The external master system clock can be applied directly through the MCLK input pin. In a system where there are a number of possible sources for the reference clock it is recommended that the clock source with the lowest jitter be used to optimise the performance of the ADC.

The master clock is used to operate the digital filters and the noise shaping circuits. The WM8781 supports master clocks of 128fs, 192fs, 256fs, 384fs, 512fs and 768fs, where fs is the audio sampling frequency (LRCLK). In Slave Mode, the WM8781 automatically detects the audio sample rate. In Master Mode, LRCLK is generated for rate 384fs, unless the user changes this to 192fs using the FSAMPEN pin = z (see Table 7 below). BCLK is also generated in Master Mode, where BCLK=64fs.

Table 6 shows the common MCLK frequencies for different sample rates.

SAMPLING RATE (LRCLK)	Master Clock Frequency (MHz)					
	128fs	192fs	256fs	384fs	512fs	768fs
8kHz	1.024	1.536	2.048	3.072	4.096	6.144
16kHz	2.048	3.072	4.096	6.144	8.192	12.288
32kHz	4.096	6.144	8.192	12.288	16.384	24.576
44.1kHz	5.6448	8.467	11.2896	16.9340	22.5792	33.8688
48kHz	6.144	9.216	12.288	18.432	24.576	36.864
96kHz	12.288	18.432	24.576	36.864	-	-
192kHz	24.576	36.864	-	-	-	-

**Table 6 Master Clock Frequency Selection**

In Slave mode, the WM8781 has a master detection circuit that automatically determines the relationship between the master clock frequency and the sampling rate (to within +/- 32 system clocks). If there is a greater than 32 clocks error the interface sets itself to the highest rate available (768fs). There must be a fixed number of MCLKS per LRCLK, although the WM8781 is tolerant of phase variations or jitter on these clocks.

The WM8781 can operate at sample rates from 8kHz to 192kHz. The WM8781 uses a sigma-delta modulator that operates at a fixed frequency of 6.144MHz (128 x LRCLK oversampling @ 48kHz sampling rate). For correct operation of the device and optimal performance, the user must set the appropriate ADC modulator sampling rate enable. In both Master and Slave Modes, it is recommended that for 96kHz the user sets FSAMPEN to 1, and for 192kHz set FSAMPEN to z. For Master Mode 192kHz, FSAMPEN set to z is a requirement.

PIN	DESCRIPTION
M/S	Master/Slave Selection 0 = Slave Mode (128fs, 192fs, 256fs, 384fs, 512fs, 768fs) 1 = Master Mode (384fs, 192fs when FSAMPEN=z)
FSAMPEN	Fast sampling rate enable 0 = 48kHz enable (128x OSR) 1 = 96kHz enable (64x OSR) z = 192kHz enable (32x OSR)

**Table 7 Master/Slave and Sampling Rate Enable Selection**

**POWER DOWN CONTROL**

The WM8781 can be powered down by stopping MCLK. Power down mode using MCLK is entered after 65536/fs clocks. On power-up, the WM8781 applies the power-on reset sequence described below.

When MCLK is stopped DOUT is forced to zero.

**POWER ON RESET**

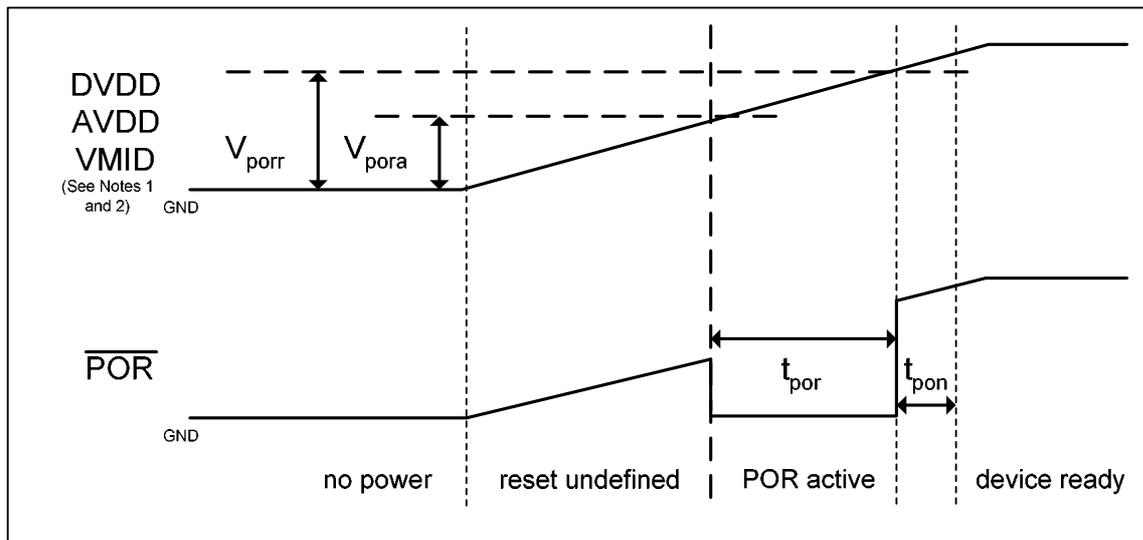

Figure 10 Power Supply Timing Requirements – power-on

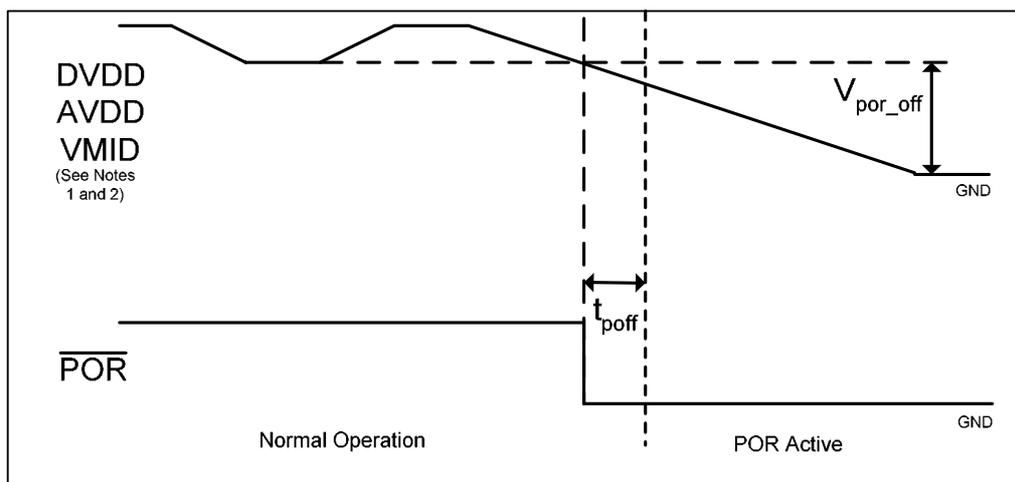

Figure 11 Power Supply Timing Requirements – power-down

**Test Conditions**AVDD = 5V, DVDD = 3.3V, AGND = DGND = 0V, T<sub>A</sub> = +25°C

PARAMETER	SYMBOL	TEST CONDITIONS	MIN	TYP	MAX	UNIT
<b>Power Supply Input Timing Information</b>						
DVDD level to activate POR – power on	V <sub>pora</sub>	Measured from DGND		0.7		V
AVDD level to activate POR – power on	V <sub>pora</sub>	Measured from AGND		0.7		V
VMID level to activate POR – power on	V <sub>pora</sub>	Measured from AGND		0.7		V
DVDD level to release POR – power on (see notes 1 and 2)	V <sub>porr</sub>	Measured from DGND		DVDD Min		V
AVDD level to release POR – power on (see notes 1 and 2)	V <sub>porr</sub>	Measured from AGND		AVDD Min		V
VMID level to release POR – power on (see notes 1 and 2)	V <sub>porr</sub>	Measured from AGND		1		V
POR active period (see notes 1 and 2)	t <sub>por</sub>	Measured from POR active to POR release	30 (note 6)	Defined by DVDD/AVDD/ VMID Rise Time		μs
DVDD level to activate POR – power off (see note 5)	V <sub>por_off</sub>	Measured from DGND		0.8		V
AVDD level to activate POR – power off (see note 5)	V <sub>por_off</sub>	Measured from AGND		0.8		V
VMID level to activate POR – power off (see note 5)	V <sub>por_off</sub>	Measured from AGND		0.7		V
Power on - POR propagation delay through device	t <sub>pon</sub>	Measured from rising EDGE of POR		30		μs
Power down - POR propagation delay through device	t <sub>poff</sub>	Measured from falling EDGE of POR		30		μs

**Notes:**

- POR is activated when DVDD or AVDD or VMID reach their stated V<sub>pora</sub> level (Figure 10).
- POR is only released when DVDD and AVDD and VMID have all reached their stated V<sub>porr</sub> levels (Figure 10).
- The rate of rise of VMID depends on the rate of rise of AVDD, the internal 50kΩ resistance and the external decoupling capacitor. Typical tolerance of 50K resistor can be taken as +/-20%.
- If AVDD, DVDD or VMID suffer a brown-out (i.e. drop below the minimum recommended operating level but do not go below V<sub>por\_off</sub>), then the chip will not reset and will resume normal operation when the voltage is back to the recommended level again.
- The chip will enter reset at power down when AVDD or DVDD or VMID falls below V<sub>por\_off</sub>. This may be important if the supply is turned on and off frequently by a power management system.
- The minimum t<sub>por</sub> period is maintained even if DVDD, AVDD and VMID have zero rise time. This specification is guaranteed by design rather than test.

## DIGITAL FILTER CHARACTERISTICS

The WM8781 digital filter characteristics scale with sample rate.

PARAMETER	TEST CONDITIONS	MIN	TYP	MAX	UNIT
<b>ADC Sample Rate (Single Rate – 48Hz typically)</b>					
Passband	+/- 0.01dB	0		0.4535fs	
	-6dB		0.4892fs		
Passband Ripple				+/- 0.01	dB
Stopband		0.5465fs			
Stopband Attenuation	f > 0.5465fs	-65			dB
Group Delay			22		fs
<b>ADC Sample Rate (Dual Rate – 96kHz typically)</b>					
Passband	+/- 0.01dB	0		0.4535fs	
	-6dB		0.4892fs		
Passband Ripple				+/- 0.01	dB
Stopband		0.5465fs			
Stopband Attenuation	f > 0.5465fs	-65			dB
Group Delay			22		fs

Table 8 Digital Filter Characteristics

## ADC FILTER RESPONSES

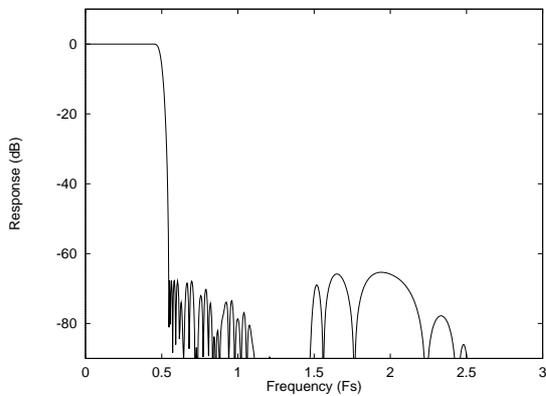

Figure 12 Digital Filter Frequency Response

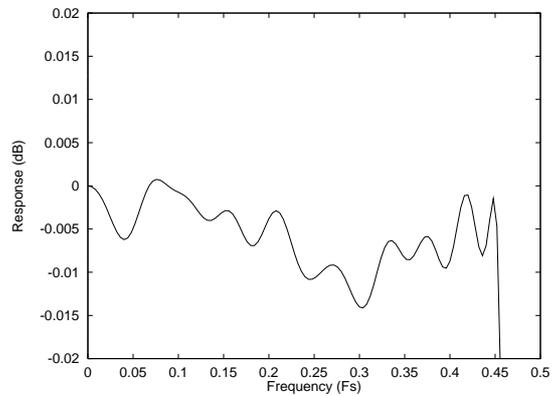

Figure 13 ADC Digital Filter Ripple

### ADC HIGH PASS FILTER

The WM8781 has a digital highpass filter to remove DC offsets. The filter response is characterised by the following polynomial.

$$H(z) = \frac{1 - z^{-1}}{1 - 0.9995z^{-1}}$$

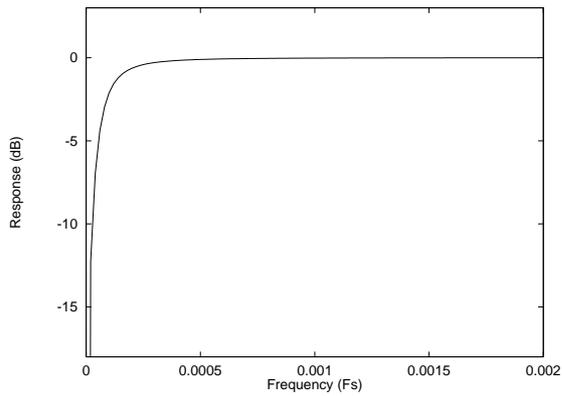

Figure 14 ADC Highpass Filter Response

APPLICATIONS INFORMATION

RECOMMENDED EXTERNAL COMPONENTS

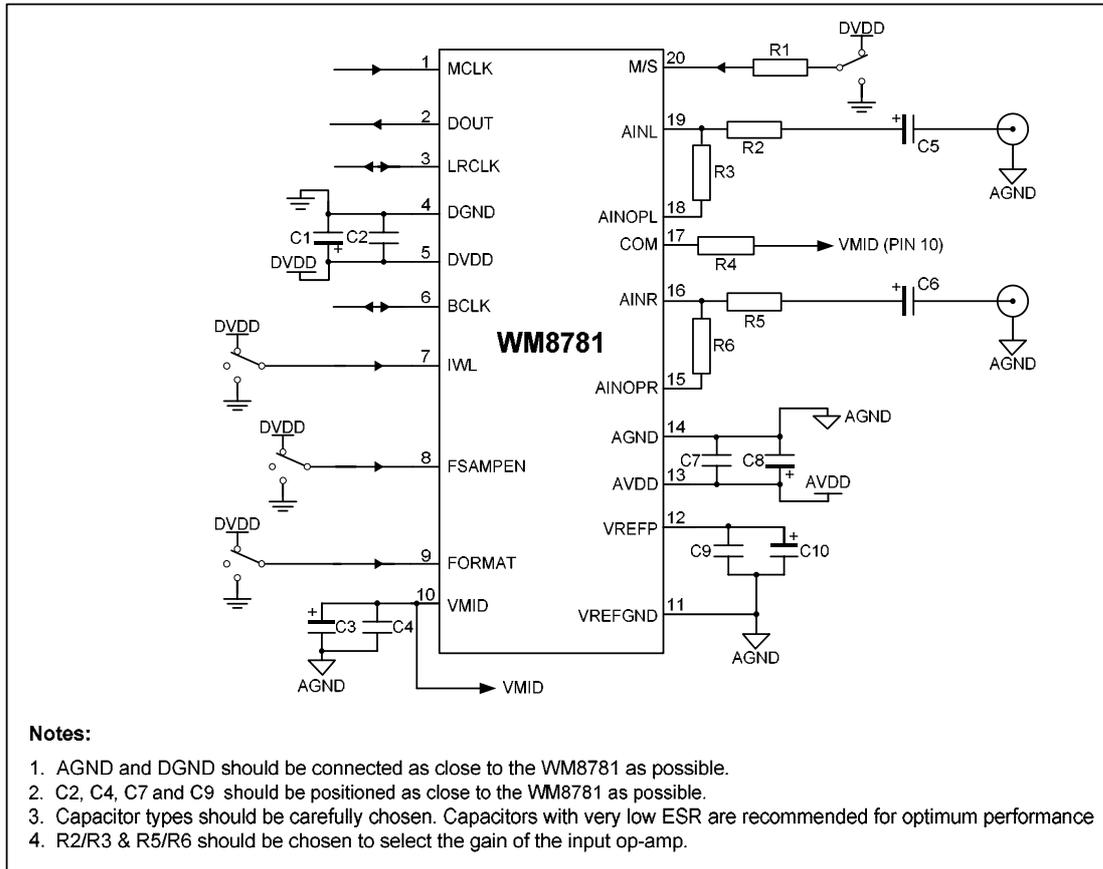

Figure 15 External Components Diagram

RECOMMENDED EXTERNAL COMPONENTS VALUES

COMPONENT REFERENCE	SUGGESTED VALUE	DESCRIPTION
C1 and C8	10µF	De-coupling for DVDD and AVDD
C2 and C7	0.1µF	De-coupling for DVDD and AVDD
C5 and C6	10µF	Analogue input AC coupling caps
R1	10kΩ	Current limiting resistors
R2 and R5	10kΩ	Internal op-amp input resistor
R3 and R6	5kΩ	Internal op-amp feedback resistor
R4	3.3kΩ	Common mode resistor
C4	0.1µF	Reference de-coupling capacitors for VMID pin
C3	10µF	
C9	0.1µF	Reference de-coupling capacitors for VREFP pin
C10	10µF	

Table 9 External Components Description

**PACKAGE DIMENSIONS**

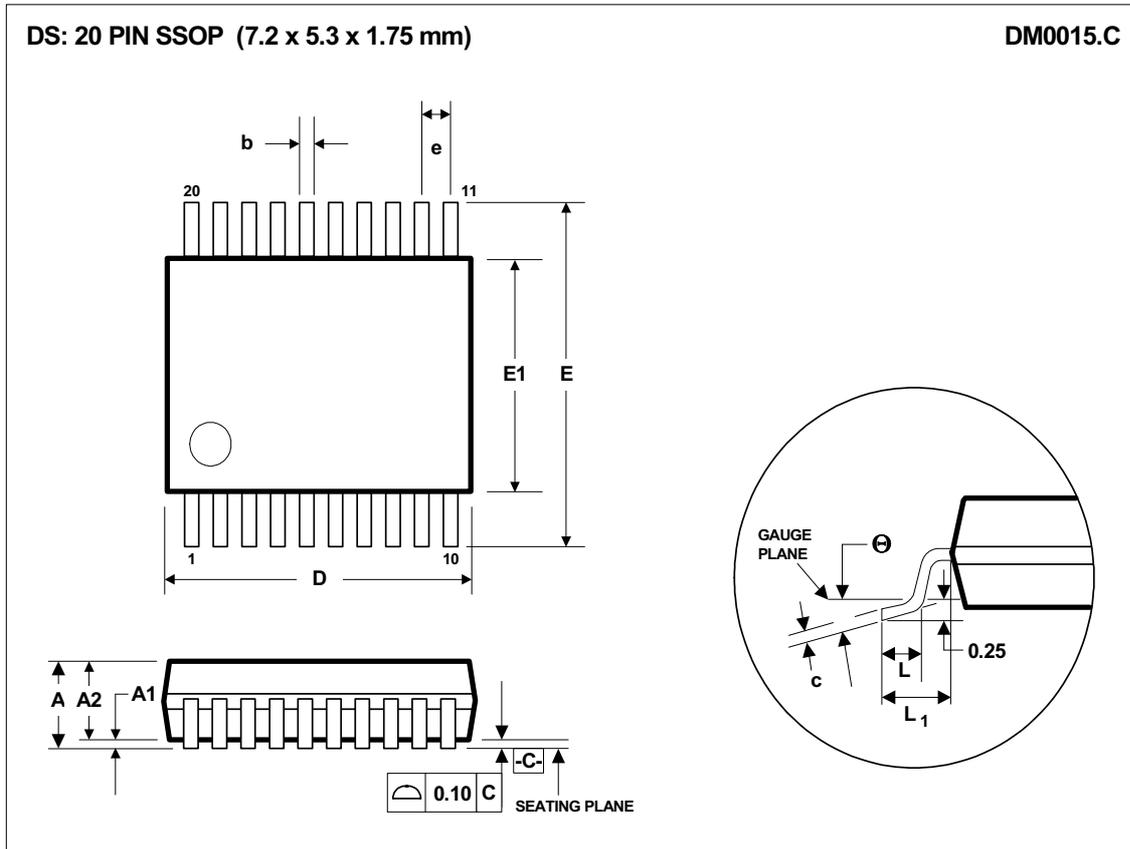

Symbols	Dimensions (mm)		
	MIN	NOM	MAX
<b>A</b>	-----	-----	2.0
<b>A<sub>1</sub></b>	0.05	-----	-----
<b>A<sub>2</sub></b>	1.65	1.75	1.85
<b>b</b>	0.22	0.30	0.38
<b>c</b>	0.09	-----	0.25
<b>D</b>	6.90	7.20	7.50
<b>e</b>	0.65 BSC		
<b>E</b>	7.40	7.80	8.20
<b>E<sub>1</sub></b>	5.00	5.30	5.60
<b>L</b>	0.55	0.75	0.95
<b>L<sub>1</sub></b>	1.25 REF		
<b>θ</b>	0°	4°	8°
<b>REF:</b>	JEDEC.95, MO-150		

NOTES:  
 A. ALL LINEAR DIMENSIONS ARE IN MILLIMETERS.  
 B. THIS DRAWING IS SUBJECT TO CHANGE WITHOUT NOTICE.  
 C. BODY DIMENSIONS DO NOT INCLUDE MOLD FLASH OR PROTRUSION, NOT TO EXCEED 0.20MM.  
 D. MEETS JEDEC.95 MO-150, VARIATION = AE. REFER TO THIS SPECIFICATION FOR FURTHER DETAILS.

## IMPORTANT NOTICE

Wolfson Microelectronics plc (WM) reserve the right to make changes to their products or to discontinue any product or service without notice, and advise customers to obtain the latest version of relevant information to verify, before placing orders, that information being relied on is current. All products are sold subject to the WM terms and conditions of sale supplied at the time of order acknowledgement, including those pertaining to warranty, patent infringement, and limitation of liability.

WM warrants performance of its products to the specifications applicable at the time of sale in accordance with WM's standard warranty. Testing and other quality control techniques are utilised to the extent WM deems necessary to support this warranty. Specific testing of all parameters of each device is not necessarily performed, except those mandated by government requirements.

In order to minimise risks associated with customer applications, adequate design and operating safeguards must be used by the customer to minimise inherent or procedural hazards. Wolfson products are not authorised for use as critical components in life support devices or systems without the express written approval of an officer of the company. Life support devices or systems are devices or systems that are intended for surgical implant into the body, or support or sustain life, and whose failure to perform when properly used in accordance with instructions for use provided, can be reasonably expected to result in a significant injury to the user. A critical component is any component of a life support device or system whose failure to perform can be reasonably expected to cause the failure of the life support device or system, or to affect its safety or effectiveness.

WM assumes no liability for applications assistance or customer product design. WM does not warrant or represent that any license, either express or implied, is granted under any patent right, copyright, mask work right, or other intellectual property right of WM covering or relating to any combination, machine, or process in which such products or services might be or are used. WM's publication of information regarding any third party's products or services does not constitute WM's approval, license, warranty or endorsement thereof.

Reproduction of information from the WM web site or datasheets is permissible only if reproduction is without alteration and is accompanied by all associated warranties, conditions, limitations and notices. Representation or reproduction of this information with alteration voids all warranties provided for an associated WM product or service, is an unfair and deceptive business practice, and WM is not responsible nor liable for any such use.

Resale of WM's products or services with statements different from or beyond the parameters stated by WM for that product or service voids all express and any implied warranties for the associated WM product or service, is an unfair and deceptive business practice, and WM is not responsible nor liable for any such use.

### ADDRESS:

Wolfson Microelectronics plc  
Westfield House  
26 Westfield Road  
Edinburgh  
EH11 2QB  
United Kingdom

Tel :: +44 (0)131 272 2000

Fax :: +44 (0)131 272 7001

Email :: [sales@wolfsonmicro.com](mailto:sales@wolfsonmicro.com)