



CYPRESS

W144

# 440BX AGPset Spread Spectrum Frequency Synthesizer

## Features

- Maximized electromagnetic interference (EMI) suppression using Cypress' Spread Spectrum technology
- Single chip system frequency synthesizer for Intel® 440BX AGPset
- Two copies of CPU output
- Six copies of PCI output 1
- One 48-MHz output for USB
- One 24-MHz output for SIO
- Two buffered reference outputs
- One IOAPIC output
- Thirteen SDRAM outputs provide support for three DIMMs
- Supports frequencies up to 150 MHz
- I<sup>2</sup>C interface for programming
- Power management control inputs

Table 1. Pin Selectable Frequency

Input Address				CPU_F, CPU1 (MHz)	PCI_F, 1:5 (MHz)
FS3	FS2	FS1	FS0		
1	1	1	1	133.6	33.4 (CPU/4)
1	1	1	0	124	31 (CPU/4)
1	1	0	1	150	37.5 (CPU/4)
1	1	0	0	140	35 (CPU/4)
1	0	1	1	105	35 (CPU/3)
1	0	1	0	110	36.7 (CPU/3)
1	0	0	1	115	38.3 (CPU/3)
1	0	0	0	120	40 (CPU/3)
0	1	1	1	100.2	33.4 (CPU/3)
0	1	1	0	133.3	44.43 (CPU/3)
0	1	0	1	112	37.3 (CPU/3)
0	1	0	0	103	34.3 (CPU/3)
0	0	1	1	66.8	33.4 (CPU/2)
0	0	1	0	83.3	41.7 (CPU/2)
0	0	0	1	75	37.5 (CPU/2)
0	0	0	0	124	41.3 (CPU/3)

## Logic Block Diagram

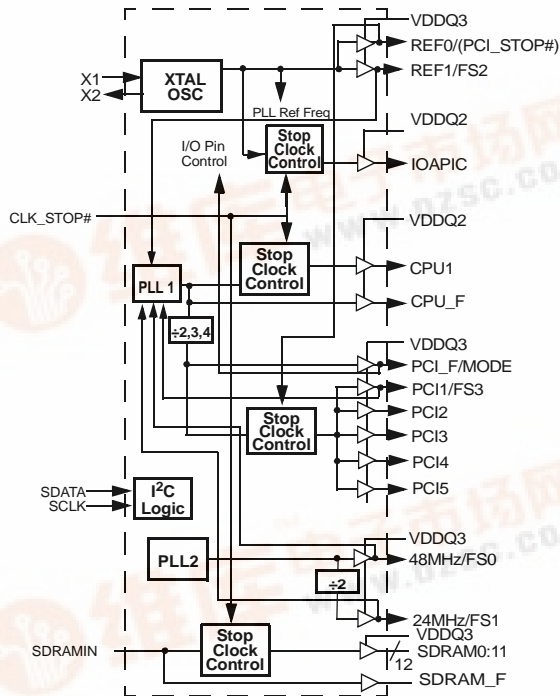

## Pin Configuration<sup>[1]</sup>

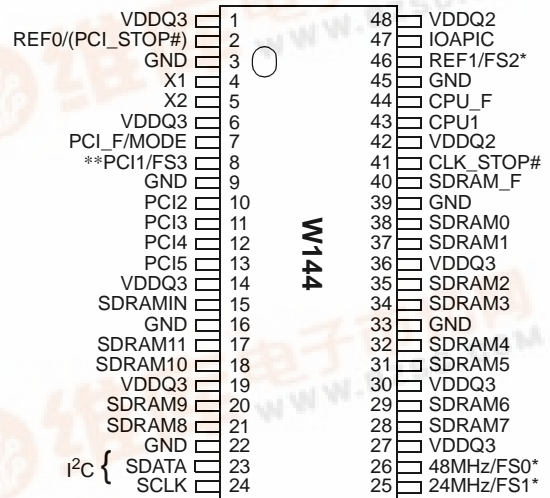

**Note:**

1. \* has an internal pull-up resistors. It should not be relied upon for setting I/O pins HIGH. Pin function with parentheses determined by MODE pin resistor strapping while \*\* has an internal pull down resistor.

**Pin Description**

Pin Name	No.	Type	Description
CPU_F	44	O	<b>Free-running CPU Clock:</b> Output voltage swing is controlled by the voltage applied to VDDQ2. See <i>Tables 1</i> and <i>6</i> for detailed frequency information.
CPU1	43	O	<b>CPU Clock Output 1:</b> This CPU clock output is controlled by the CLK_STOP# control pin. Output voltage swing is controlled by voltage applied to VDDQ2.
PCI2:5	10, 11, 12, 13	O	<b>PCI Clock Outputs 2 through 5:</b> These four PCI clock outputs are controlled by the PCI_STOP# control pin. Output voltage swing is controlled by voltage applied to VDDQ3.
PCI1/FS3	8	I/O	<b>Fixed PCI Clock Output:</b> As an output, frequency is set by the FS0:3 inputs or through serial input interface, see <i>Tables 1</i> and <i>6</i> . This output is affected by the PCI_STOP# input. When an input, latches data selecting the frequency of the CPU and PCI outputs.
PCI_F/MODE	7	I/O	<b>Fixed PCI Clock Output:</b> As an output, frequency is set by the FS0:3 inputs or through serial input interface, see <i>Tables 1</i> and <i>6</i> . This output is not affected by the PCI_STOP# input. When an input, sets function of pin 2.
CLK_STOP#	41	I	<b>CLK_STOP# input:</b> When brought LOW, affected clock outputs are stopped LOW after completing a full clock cycle (2–3 CPU clock latency). When brought HIGH, affected clock outputs start, beginning with a full clock cycle (2–3 CPU clock latency).
IOAPIC	47	O	<b>IOAPIC Clock Output:</b> Provides 14.318-MHz fixed frequency. The output voltage swing is controlled by VDDQ2. This output is disabled when CLK_STOP# is set LOW.
48MHz/FS0	26	I/O	<b>48-MHz Output:</b> 48 MHz is provided in normal operation. In standard systems, this output can be used as the reference for the Universal Serial Bus. Upon power-up FS0 input will be latched, which will set clock frequencies as described in <i>Table 1</i> .
24MHz/FS1	25	I/O	<b>24-MHz Output:</b> 24 MHz is provided in normal operation. In standard systems, this output can be used as the clock input for a Super I/O chip. Upon power-up FS1 input will be latched, which will set clock frequencies as described in <i>Table 1</i> .
REF1/FS2	46	I/O	<b>I/O Dual-Function REF0 and FS2 pin:</b> Upon power-up, FS2 input will be latched, which will set clock frequencies as described in <i>Table 1</i> . When an output, this pin provides a fixed clock signal equal in frequency to the reference signal provided at the X1/X2 pins.
REF0/ (PCI_STOP#)	2	I/O	<b>Fixed 14.318-MHz Output 0 or PCI_STOP# Pin:</b> Function determined by MODE pin. The PCI_STOP# input enables the PCI 1:5 outputs when HIGH and causes them to remain at logic 0 when LOW. The PCI_STOP signal is latched on the rising edge of PCI_F. Its effects take place on the next PCI_F clock cycle. When an output, this pin provides a fixed clock signal equal in frequency to the reference signal provided at the X1/X2 pins.
SDRAMIN	15	I	<b>Buffered Input Pin:</b> The signal provided to this input pin is buffered to 13 outputs (SDRAM0:11, SDRAM_F).
SDRAM0:11	38, 37, 35, 34, 32, 31, 29, 28, 21, 20, 18, 17	O	<b>Buffered Outputs:</b> These twelve dedicated outputs provide copies of the signal provided at the SDRAMIN input. The swing is set by VDDQ3, and they are deactivated when CLK_STOP# input is set LOW.
SDRAM_F	40	O	<b>Free-running Buffered Output:</b> This dedicated output provides a copy of the SDRAMIN input which is not affected by the CLK_STOP# input
SCLK	24	I	<b>Clock pin for I<sup>2</sup>C Circuitry</b>
SDATA	23	I/O	<b>Data pin for I<sup>2</sup>C Circuitry</b>
X1	4	I	<b>Crystal Connection or External Reference Frequency Input:</b> This pin has dual functions. It can be used as an external 14.318-MHz crystal connection or as an external reference frequency input.
X2	5	I	<b>Crystal Connection:</b> An input connection for an external 14.318-MHz crystal. If using an external reference, this pin must be left unconnected.
VDDQ3	1, 6, 14, 19, 27, 30, 36	P	<b>Power Connection:</b> Power supply for core logic, PLL circuitry, SDRAM outputs, PCI outputs, reference outputs, 48-MHz output, and 24-MHz output. Connect to 3.3V supply.
VDDQ2	42, 48	P	<b>Power Connection:</b> Power supply for IOAPIC, CPU_F, and CPU1 output buffers. Connect to 2.5V or 3.3V.
GND	3, 9, 16, 22, 33, 39, 45	G	<b>Ground Connections:</b> Connect all ground pins to the common system ground plane.

**Key Specifications**

CPU Cycle-to-Cycle Jitter: ..... 250 ps  
 CPU to CPU Output Skew: ..... 175 ps  
 PCI to PCI Output Skew: ..... 500 ps  
 $V_{DDQ3}$ : .....  $3.3V \pm 5\%$   
 $V_{DDQ2}$ : .....  $2.5V \pm 5\%$   
 SDRAMIN to SDRAM0:11 Delay: ..... 3.7 ns typ.  
 SDRAM0:11 (leads) to SDRAM\_F Skew: ..... 0.4 ns typ.

**Table 2. Mode Input Table**

Mode	Pin2
0	PCI_STOP#
1	REF0

**Overview**

The W144 was developed as a single-chip device to meet the clocking needs of the Intel 440BX AGPset. In addition to the typical outputs provided by standard 100-MHz 440BX FTGs, the W144 adds a thirteen output buffer, supporting SDRAM DIMM modules in conjunction with the chipset.

Cypress's proprietary spread spectrum frequency synthesis technique is a feature of the CPU and PCI outputs. When enabled, this feature reduces the peak EMI measurements of not only the output signals and their harmonics, but also of any other clock signals that are properly synchronized to them.

**Functional Description**

**I/O Pin Operation**

Pins 7, 8, 25, 26, and 46 are dual-purpose I/O pins. Upon power-up these pins act as logic inputs, allowing the determi-

nation of assigned device functions. A short time after power-up, the logic state of each pin is latched and the pins become clock outputs. This feature reduces device pin count by combining clock outputs with input select pins.

An external 10-k $\Omega$  "strapping" resistor is connected between the I/O pin and ground or  $V_{DD}$ . Connection to ground sets a latch to "0," connection to  $V_{DD}$  sets a latch to "1." *Figure 1* and *Figure 2* show two suggested methods for strapping resistor connections.

Upon W144 power up, the first 2 ms of operation is used for input logic selection. During this period, the five I/O pins (7, 8, 25, 26, 46) are three-stated, allowing the output strapping resistor on the I/O pins to pull the pin and their associated capacitive clock load to either a logic HIGH or LOW state. At the end of the 2ms period, the established logic "0" or "1" condition of the I/O pin is latched. Next the output buffer is enabled converting the I/O pins into operating clock outputs. The 2-ms timer starts when  $V_{DD}$  reaches 2.0V. The input bits can only be reset by turning  $V_{DD}$  off and then back on again.

It should be noted that the strapping resistors have no significant effect on clock output signal integrity. The drive impedance of clock outputs are  $<40\Omega$  (nominal) which is minimally affected by the 10-k $\Omega$  strap to ground or  $V_{DD}$ . As with the series termination resistor, the output strapping resistor should be placed as close to the I/O pin as possible in order to keep the interconnecting trace short. The trace from the resistor to ground or  $V_{DD}$  should be kept less than two inches in length to prevent system noise coupling during input logic sampling.

When the clock outputs are enabled following the 2-ms input period, the specified output frequency is delivered on the pin, assuming that  $V_{DD}$  has stabilized. If  $V_{DD}$  has not yet reached full value, output frequency initially may be below target but will increase to target once  $V_{DD}$  voltage has stabilized. In either case, a short output clock cycle may be produced from the CPU clock outputs when the outputs are enabled.

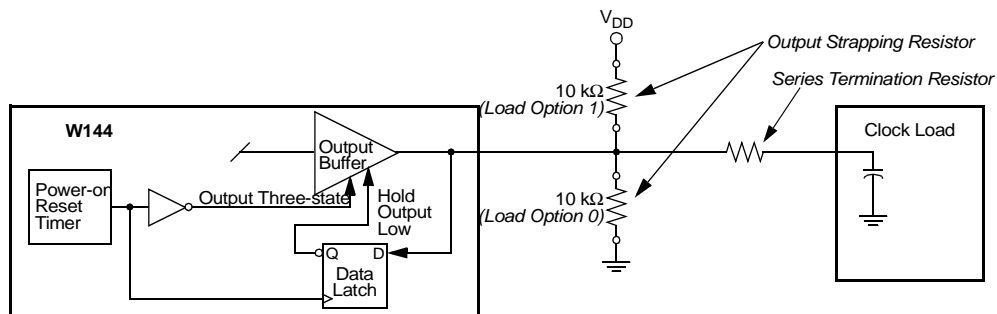

**Figure 1. Input Logic Selection Through Resistor Load Option**

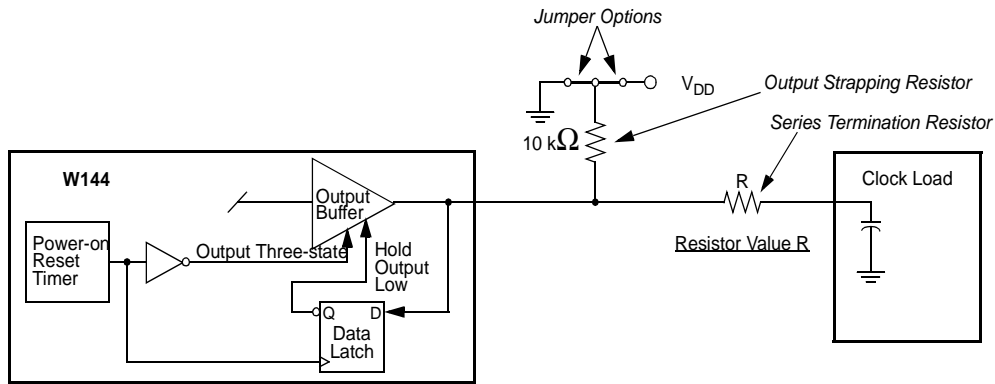

Figure 2. Input Logic Selection Through Jumper Option

**Spread Spectrum Feature**

The device generates a clock that is frequency modulated in order to increase the bandwidth that it occupies. By increasing the bandwidth of the fundamental and its harmonics, the amplitudes of the radiated electromagnetic emissions are reduced. This effect is depicted in Figure 3.

As shown in Figure 3, a harmonic of a modulated clock has a much lower amplitude than that of an unmodulated signal. The reduction in amplitude is dependent on the harmonic number and the frequency deviation or spread. The equation for the reduction is

$$dB = 6.5 + 9 \cdot \log_{10}(P) + 9 \cdot \log_{10}(F)$$

Where *P* is the percentage of deviation and *F* is the frequency in MHz where the reduction is measured.

The output clock is modulated with a waveform depicted in Figure 4. This waveform, as discussed in “Spread Spectrum Clock Generation for the Reduction of Radiated Emissions” by Bush, Fessler, and Hardin produces the maximum reduction in the amplitude of radiated electromagnetic emissions. The deviation selected for this chip is specified in Table 7. Figure 4 details the Cypress spreading pattern. Cypress does offer options with more spread and greater EMI reduction. Contact your local Sales representative for details on these devices.

Spread Spectrum clocking is activated or deactivated by selecting the appropriate values for bits 1–0 in data byte 0 of the I<sup>2</sup>C data stream. Refer to Table 7 for more details.

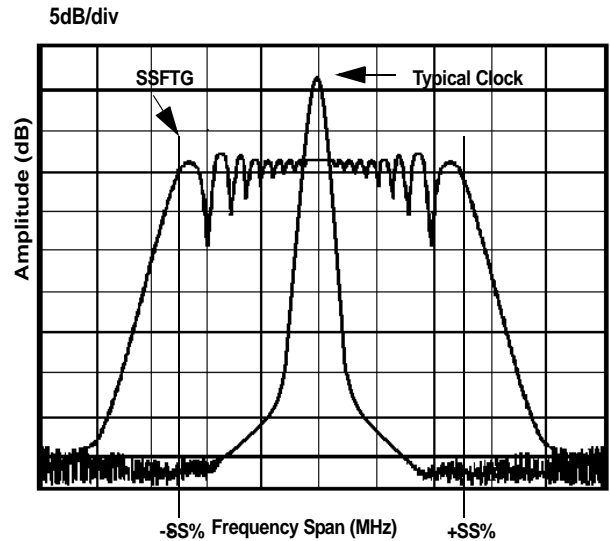

Figure 3. Clock Harmonic with and without SSCG Modulation Frequency Domain Representation

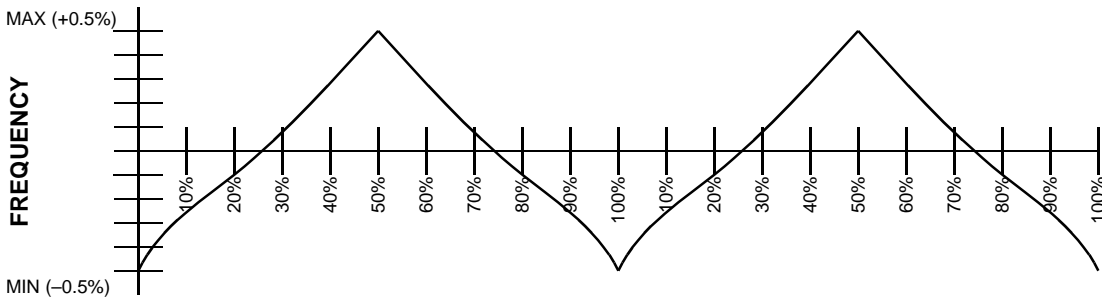

Figure 4. Typical Modulation Profile

## Serial Data Interface

The W144 features a two-pin, serial data interface that can be used to configure internal register settings that control particular device functions. Upon power-up, the W144 initializes with default register settings, therefore the use of this serial data interface is optional. The serial interface is write-only (to the clock chip) and is the dedicated function of device pins SDATA and SCLOCK. In motherboard applications, SDATA and SCLOCK are typically driven by two logic outputs of the chipset. Clock device register changes are normally made upon system initialization, if any are required. The interface can also be used during system operation for power management functions. *Table 3* summarizes the control functions of the serial data interface.

## Operation

Data is written to the W144 in eleven bytes of eight bits each. Bytes are written in the order shown in *Table 4*.

**Table 3. Serial Data Interface Control Functions Summary**

Control Function	Description	Common Application
Clock Output Disable	Any individual clock output(s) can be disabled. Disabled outputs are actively held LOW.	Unused outputs are disabled to reduce EMI and system power. Examples are clock outputs to unused PCI slots.
CPU Clock Frequency Selection	Provides CPU/PCI frequency selections through software. Frequency is changed in a smooth and controlled fashion.	For alternate microprocessors and power management options. Smooth frequency transition allows CPU frequency change under normal system operation.
Spread Spectrum Enabling	Enables or disables spread spectrum clocking.	For EMI reduction.
Output Three-state	Puts clock output into a high-impedance state.	Production PCB testing.
(Reserved)	Reserved function for future device revision or production device testing.	No user application. Register bit must be written as 0.

**Table 4. Byte Writing Sequence**

Byte Sequence	Byte Name	Bit Sequence	Byte Description
1	Slave Address	11010010	Commands the W144 to accept the bits in Data Bytes 0–6 for internal register configuration. Since other devices may exist on the same common serial data bus, it is necessary to have a specific slave address for each potential receiver. The slave receiver address for the W144 is 11010010. Register setting will not be made if the Slave Address is not correct (or is for an alternate slave receiver).
2	Command Code	Don't Care	Unused by the W144, therefore bit values are ignored ("don't care"). This byte must be included in the data write sequence to maintain proper byte allocation. The Command Code Byte is part of the standard serial communication protocol and may be used when writing to another addressed slave receiver on the serial data bus.
3	Byte Count	Don't Care	Unused by the W144, therefore bit values are ignored ("don't care"). This byte must be included in the data write sequence to maintain proper byte allocation. The Byte Count Byte is part of the standard serial communication protocol and may be used when writing to another addressed slave receiver on the serial data bus.

**Table 4. Byte Writing Sequence** (continued)

Byte Sequence	Byte Name	Bit Sequence	Byte Description
4	Data Byte 0	Refer to <i>Table 5</i>	The data bits in Data Bytes 0–7 set internal W144 registers that control device operation. The data bits are only accepted when the Address Byte bit sequence is 11010010, as noted above. For description of bit control functions, refer to <i>Table 5</i> , Data Byte Serial Configuration Map.
5	Data Byte 1		
6	Data Byte 2		
7	Data Byte 3		
8	Data Byte 4		
9	Data Byte 5		
10	Data Byte 6		
11	Data Byte 7		

**Writing Data Bytes**

Each bit in Data Bytes 0–7 controls a particular device function except for the “reserved” bits, which must be written as a logic 0. Bits are written MSB (most significant bit) first, which is bit 7. *Table 5* gives the bit formats for registers located in Data Bytes 0–7.

*Table 6* details additional frequency selections that are available through the serial data interface.

*Table 7* details the select functions for Byte 0, bits 1 and 0.

**Table 5. Data Bytes 0-7 Serial Configuration Map**

Bit(s)	Affected Pin		Control Function	Bit Control		Default
	Pin No.	Pin Name		0	1	
<b>Data Byte 0</b>						
7	–	–	(Reserved)	–	–	0
6	–	–	SEL_2	See <i>Table 6</i>		0
5	–	–	SEL_1	See <i>Table 6</i>		0
4	–	–	SEL_0	See <i>Table 6</i>		0
3	–	–	Hardware/Software Frequency Select	Hardware	Software	0
2	–	–	SEL_3	See <i>Table 6</i>		0
1–0	–	–	<u>Bit 1Bit 0Function (See <i>Table 7</i> for function details)</u> 00Normal Operation 01(Reserved) 10Spread Spectrum On 11All Outputs Three-stated			00

**Data Byte 1**

7	–	–	(Reserved)	–	–	0
6	–	–	(Reserved)	–	–	0
5	–	–	(Reserved)	–	–	0
4	–	–	(Reserved)	–	–	0
3	40	SDRAM_F	Clock Output Disable	Low	Active	1
2	–	–	(Reserved)	–	–	0
1	43	CPU1	Clock Output Disable	Low	Active	1
0	44	CPU_F	Clock Output Disable	Low	Active	1

**Data Byte 2**

7	–	–	(Reserved)	–	–	0
6	7	PCI_F	Clock Output Disable	Low	Active	1
5	–	–	(Reserved)	–	–	0
4	13	PCI5	Clock Output Disable	Low	Active	1
3	12	PCI4	Clock Output Disable	Low	Active	1
2	11	PCI3	Clock Output Disable	Low	Active	1
1	10	PCI2	Clock Output Disable	Low	Active	1
0	8	PCI1	Clock Output Disable	Low	Active	1

**Data Byte 3**

7	–	–	(Reserved)	–	–	0
6	–	–	(Reserved)	–	–	0
5	26	48MHz	Clock Output Disable	Low	Active	1
4	25	24MHz	Clock Output Disable	Low	Active	1
3	–	–	(Reserved)	–	–	0
2	21, 20, 18, 17	SDRAM8:11	Clock Output Disable	Low	Active	1
1	32, 31, 29, 28	SDRAM4:7	Clock Output Disable	Low	Active	1
0	38, 37, 35, 34	SDRAM0:3	Clock Output Disable	Low	Active	1

**Data Byte 4**

7	–	–	(Reserved)	–	–	0
6	–	–	(Reserved)	–	–	0
5	–	–	(Reserved)	–	–	0
4	–	–	(Reserved)	–	–	0
3	–	–	(Reserved)	–	–	0
2	–	–	(Reserved)	–	–	0
1	–	–	(Reserved)	–	–	0
0	–	–	(Reserved)	–	–	0

**Data Byte 5**

7	–	–	(Reserved)	–	–	0
6	–	–	(Reserved)	–	–	0
5	–	–	(Reserved)	–	–	0
4	47	IOAPIC	Clock Output Disable	Low	Active	1
3	–	–	(Reserved)	–	–	0
2	–	–	(Reserved)	–	–	0
1	46	REF1	Clock Output Disable	Low	Active	1
0	2	REF0	Clock Output Disable	Low	Active	1

**Data Byte 6**

7	–	–	(Reserved)	–	–	0
6	–	–	(Reserved)	–	–	0
5	–	–	(Reserved)	–	–	0
4	–	–	(Reserved)	–	–	0
3	–	–	(Reserved)	–	–	0

**Data Byte 6 (continued)**

2	–	–	(Reserved)	–	–	0
1	–	–	(Reserved)	–	–	0
0	–	–	(Reserved)	–	–	0

**Data Byte 7**

7	–	–	(Reserved)	–	–	0
6	–	–	(Reserved)	–	–	0
5	–	–	(Reserved)	–	–	0
4	–	–	(Reserved)	–	–	0
3	–	–	(Reserved)	–	–	0
2	–	–	(Reserved)	–	–	0
1	–	–	(Reserved)	–	–	0
0	–	–	(Reserved)	–	–	0

**Table 6. Additional Frequency Selections through Serial Data Interface Data Bytes<sup>[2]</sup>**

Input Conditions				Output Frequency	
Data Byte 0, Bit 3 = 1				CPU, SDRAM Clocks (MHz)	PCI Clocks (MHz)
Bit 2 SEL_3	Bit 6 SEL_2	Bit 5 SEL_1	Bit 4 SEL_0		
1	1	1	1	133.6	33.4 (CPU/4)
1	1	1	0	124	31 (CPU/4)
1	1	0	1	150	37.5 (CPU/4)
1	1	0	0	140	35 (CPU/4)
1	0	1	1	105	35 (CPU/3)
1	0	1	0	110	36.7 (CPU/3)
1	0	0	1	115	39.3 (CPU/3)
1	0	0	0	120	40 (CPU/3)
0	1	1	1	100.2	33.4 (CPU/3)
0	1	1	0	133	44.3 (CPU/3)
0	1	0	1	112	37.3 (CPU/3)
0	1	0	0	103	34.3 (CPU/3)
0	0	1	1	66.8	33.4 (CPU/2)
0	0	1	0	83.3	41.7 (CPU/2)
0	0	0	1	75	37.5 (CPU/2)
0	0	0	0	124	41.3 (CPU/3)

**Table 7. Select Function for Data Byte 0, Bits 0:1**

Function	Input Conditions		Output Conditions				
	Data Byte 0		CPU_F, CPU1	PCI_F, PCI1:5	REF0:1, IOAPIC	48MHZ	24MHZ
	Bit 1	Bit 0					
Normal Operation	0	0	Note 1	Note 1	14.318 MHz	48 MHz	24 MHz
Spread Spectrum	1	0	±0.5%	±0.5%	14.318 MHz	48 MHz	24 MHz
Three-state	1	1	Hi-Z	Hi-Z	Hi-Z	Hi-Z	Hi-Z

**Note:**

 2. CPU and PCI frequency selections are listed in *Table 1* and *Table 6*.





**Absolute Maximum Conditions**<sup>[3]</sup>

Stresses greater than those listed in this table may cause permanent damage to the device. These represent a stress

rating only. Operation of the device at these or any other conditions above those specified in the operating sections of this specification is not implied. Maximum conditions for extended periods may affect reliability.

Parameter	Description	Rating	Unit
V <sub>DD</sub> , V <sub>IN</sub>	Voltage on any pin with respect to GND	-0.5 to +7.0	V
T <sub>STG</sub>	Storage Temperature	-65 to +150	°C
T <sub>B</sub>	Ambient Temperature under Bias	-55 to +125	°C
T <sub>A</sub>	Operating Temperature	0 to +70	°C
ESD <sub>PROT</sub>	Input ESD Protection	2 (min)	kV

**DC Electrical Characteristics** T<sub>A</sub> = 0°C to +70°C; V<sub>DDQ3</sub> = 3.3V±5%; V<sub>DDQ2</sub> = 2.5V±5%

Parameter	Description	Test Condition	Min.	Typ.	Max.	Unit
<b>Supply Current</b>						
I <sub>DD</sub>	3.3V Supply Current	CPU_F, CPU1 = 100.2 MHz Outputs Loaded <sup>[4]</sup>	-	260	-	mA
I <sub>DD</sub>	2.5V Supply Current	CPU_F, CPU1 = 100.2 MHz Outputs Loaded <sup>[4]</sup>	-	25	-	mA
<b>Logic Inputs</b>						
V <sub>IL</sub>	Input Low Voltage		GND - 0.3	-	0.8	V
V <sub>IH</sub>	Input High Voltage		2.0	-	V <sub>DDQ3</sub> + 0.3	V
I <sub>IL</sub>	Input Low Current <sup>[5]</sup>		-	-	-25	µA
I <sub>IH</sub>	Input High Current <sup>[5]</sup>		-	-	10	µA
I <sub>IL</sub>	Input Low Current (SEL100/66#)		-	-	-5	µA
I <sub>IH</sub>	Input High Current (SEL100/66#)		-	-	+5	µA
<b>Clock Outputs</b>						
V <sub>OL</sub>	Output Low Voltage	I <sub>OL</sub> = 1 mA	-	-	50	mV
V <sub>OH</sub>	Output High Voltage	I <sub>OH</sub> = 1 mA	3.1	-	-	V
V <sub>OH</sub>	Output High Voltage	CPU_F,1, IOAPIC I <sub>OH</sub> = -1 mA	2.2	-	-	V
I <sub>OL</sub>	Output Low Current	CPU_F, CPU1 V <sub>OL</sub> = 1.25V	27	57	97	mA
		PCI_F, PCI1:5 V <sub>OL</sub> = 1.5V	20.5	53	139	mA
		IOAPIC V <sub>OL</sub> = 1.25V	40	85	140	mA
		REF0:1 V <sub>OL</sub> = 1.5V	25	37	76	mA
		48MHz V <sub>OL</sub> = 1.5V	25	37	76	mA
		24MHz V <sub>OL</sub> = 1.5V	25	37	76	mA
I <sub>OH</sub>	Output High Current	CPU_F, CPU1 V <sub>OH</sub> = 1.25V	25	55	97	mA
		PCI_F, PCI1:5 V <sub>OH</sub> = 1.5V	31	55	139	mA
		IOAPIC V <sub>OH</sub> = 1.25V	40	87	155	mA
		REF0:1 V <sub>OH</sub> = 1.5V	27	44	94	mA
		48MHz V <sub>OH</sub> = 1.5V	27	44	94	mA
		24MHz V <sub>OH</sub> = 1.5V	25	37	76	mA

**Notes:**

- 3. **Multiple Supplies:** The voltage on any input or I/O pin cannot exceed the power pin during power-up. Power supply sequencing is NOT required.
- 4. All clock outputs loaded with 6" 60Ω traces with 22-pF capacitors.
- 5. W144 logic inputs (except FS3) have internal pull-up devices (pull-ups not full CMOS level). Logic input FS3 has an internal pull-down device.

**DC Electrical Characteristics**  $T_A = 0^\circ\text{C to } +70^\circ\text{C}$ ;  $V_{DDQ3} = 3.3\text{V}\pm 5\%$ ;  $V_{DDQ2} = 2.5\text{V}\pm 5\%$  (continued)

Parameter	Description	Test Condition	Min.	Typ.	Max.	Unit
<b>Crystal Oscillator</b>						
$V_{TH}$	X1 Input threshold Voltage <sup>[6]</sup>	$V_{DDQ3} = 3.3\text{V}$	–	1.65	–	V
$C_{LOAD}$	Load Capacitance, Imposed on External Crystal <sup>[7]</sup>		–	14	–	pF
$C_{IN,X1}$	X1 Input Capacitance <sup>[8]</sup>	Pin X2 unconnected	–	28	–	pF
<b>Pin Capacitance/Inductance</b>						
$C_{IN}$	Input Pin Capacitance	Except X1 and X2	–	–	5	pF
$C_{OUT}$	Output Pin Capacitance		–	–	6	pF
$L_{IN}$	Input Pin Inductance		–	–	7	nH

**AC Electrical Characteristics**

AC clock parameters are tested and guaranteed over stated operating conditions using the stated lump capacitive load at the clock output; Spread Spectrum clocking is disabled.

$T_A = 0^\circ\text{C to } +70^\circ\text{C}$ ;  $V_{DDQ3} = 3.3\text{V}\pm 5\%$ ;  $V_{DDQ2} = 2.5\text{V}\pm 5\%$ ;  
 $f_{XTL} = 14.31818\text{ MHz}$

**CPU Clock Outputs, CPU\_F, CPU1 (Lump Capacitance Test Load = 20 pF)**

Parameter	Description	Test Condition/Comments	CPU = 66.6 MHz			CPU = 100.2 MHz			Unit
			Min.	Typ.	Max.	Min.	Typ.	Max.	
$t_P$	Period	Measured on rising edge at 1.25	15	–	15.5	9.98	–	10.5	ns
$t_H$	High Time	Duration of clock cycle above 2.0V	5.6	–	–	3.3	–	–	ns
$t_L$	Low Time	Duration of clock cycle below 0.4V	5.3	–	–	3.1	–	–	ns
$t_R$	Output Rise Edge Rate	Measured from 0.4V to 2.0V	1.5	–	4	1.5	–	4	V/ns
$t_F$	Output Fall Edge Rate	Measured from 2.0V to 0.4V	1.5	–	4	1.5	–	4	V/ns
$t_D$	Duty Cycle	Measured on rising and falling edge at 1.25V	45	–	55	45	–	55	%
$t_{JC}$	Jitter, Cycle-to-Cycle	Measured on rising edge at 1.25V. Maximum difference of cycle time between two adjacent cycles.	–	–	200	–	–	200	ps
$t_{SK}$	Output Skew	Measured on rising edge at 1.25V	–	–	250			250	ps
$f_{ST}$	Frequency Stabilization from Power-up (cold start)	Assumes full supply voltage reached within 1 ms from power-up. Short cycles exist prior to frequency stabilization.	–	–	3	–	–	3	ms
$Z_o$	AC Output Impedance	Average value during switching transition. Used for determining series termination value.	–	20	–	–	20	–	$\Omega$

**Notes:**

- X1 input threshold voltage (typical) is  $V_{DDQ3}/2$ .
- The W144 contains an internal crystal load capacitor between pin X1 and ground and another between pin X2 and ground. Total load placed on crystal is 14 pF; this includes typical stray capacitance of short PCB traces to crystal.
- X1 input capacitance is applicable when driving X1 with an external clock source (X2 is left unconnected).

**SDRAM Clock Outputs, SDRAM, SDRAM0:11 (Lump Capacitance Test Load = 30 pF)**

Parameter	Description	Test Condition/Comments	CPU = 66.6 MHz			CPU = 100.2 MHz			Unit
			Min.	Typ.	Max.	Min.	Typ.	Max.	
t <sub>P</sub>	Period	Measured on rising edge at 1.5V	30	–	–	30	–	–	ns
t <sub>H</sub>	High Time	Duration of clock cycle above 2.4V, at min. edge rate (1.5V/ns)	5.6	–	–	3.3	–	–	ns
t <sub>L</sub>	Low Time	Duration of clock cycle below 0.4V, at min. edge rate (1.5V/ns)	5.3	–	–	3.1	–	–	ns
t <sub>R</sub>	Output Rise Edge Rate	Measured from 0.4V to 2.4V	1.5	–	4	1.5	–	4	V/ns
t <sub>F</sub>	Output Fall Edge Rate	Measured from 2.4V to 0.4V	1.5	–	4	1.5	–	4	V/ns
t <sub>PLH</sub>	Prop Delay LH	Input edge rate faster than 1V/ns	1	–	5	1	–	5	ns
t <sub>PHL</sub>	Prop Delay HL	Input edge rate faster than 1 V/ns	1	–	5	1	–	5	ns
t <sub>D</sub>	Duty Cycle	Measured on rising and falling edge at 1.5V, at min. edge rate (1.5 V/ns)	45	–	55	45	–	55	%
t <sub>JC</sub>	Jitter, Cycle-to-Cycle	Measured on rising edge at 1.5V. Maximum difference of cycle time between two adjacent cycles.	–	–	250	–	–	250	ps
t <sub>SK</sub>	Output Skew	Measured on rising edge at 1.5V	–	–	250	–	–	250	ps
t <sub>O</sub>	CPU to PCI Clock Skew	Covers all CPU/PCI outputs. Measured on rising edge at 1.5V. CPU leads PCI output.	1.5	–	4	1.5	–	4	ns
f <sub>ST</sub>	Frequency Stabilization from Power-up (cold start)	Assumes full supply voltage reached within 1 ms from power-up. Short cycles exist prior to frequency stabilization.	–	–	3	–	–	3	ms
Z <sub>O</sub>	AC Output Impedance	Average value during switching transition. Used for determining series termination value.	–	30	–	–	30	–	Ω

**PCI Clock Outputs, PCI\_F and PCI1:5 (Lump Capacitance Test Load = 30 pF)**

Parameter	Description	Test Condition/Comments	CPU = 66.6/100.2 MHz			Unit
			Min.	Typ.	Max.	
t <sub>P</sub>	Period	Measured on rising edge at 1.5V	29.9	–	–	ns
t <sub>H</sub>	High Time	Duration of clock cycle above 2.4V	12.0	–	–	ns
t <sub>L</sub>	Low Time	Duration of clock cycle below 0.4V	12.0	–	–	ns
t <sub>R</sub>	Output Rise Edge Rate	Measured from 0.4V to 2.4V	1	–	4	V/ns
t <sub>F</sub>	Output Fall Edge Rate	Measured from 2.4V to 0.4V	1	–	4	V/ns
t <sub>D</sub>	Duty Cycle	Measured on rising and falling edge at 1.5V	45	–	55	%
t <sub>JC</sub>	Jitter, Cycle-to-Cycle	Measured on rising edge at 1.5V. Maximum difference of cycle time between two adjacent cycles.	–	–	250	ps
t <sub>SK</sub>	Output Skew	Measured on rising edge at 1.5V	–	–	500	ps
t <sub>O</sub>	CPU to PCI Clock Skew	Covers all CPU/PCI outputs. Measured on rising edge at 1.5V. CPU leads PCI output.	1.5	–	4.0	ns
f <sub>ST</sub>	Frequency Stabilization from Power-up (cold start)	Assumes full supply voltage reached within 1 ms from power-up. Short cycles exist prior to frequency stabilization.	–	–	3.0	ms
Z <sub>O</sub>	AC Output Impedance	Average value during switching transition. Used for determining series termination value.	–	30	–	Ω

**IOAPIC Clock Output (Lump Capacitance Test Load = 20 pF)**

Parameter	Description	Test Condition/Comments	CPU = 66.6/100.2 MHz			Unit
			Min.	Typ.	Max.	
f	Frequency, Actual	Frequency generated by crystal oscillator	14.31818			MHz
t <sub>R</sub>	Output Rise Edge Rate	Measured from 0.4V to 2.0V	1	–	4	V/ns
t <sub>F</sub>	Output Fall Edge Rate	Measured from 2.0V to 0.4V	1	–	4	V/ns
t <sub>D</sub>	Duty Cycle	Measured on rising and falling edge at 1.25V	45	–	55	%
f <sub>ST</sub>	Frequency Stabilization from Power-up (cold start)	Assumes full supply voltage reached within 1 ms from power-up. Short cycles exist prior to frequency stabilization.	–	–	1.5	ms
Z <sub>o</sub>	AC Output Impedance	Average value during switching transition. Used for determining series termination value.	–	15	–	Ω

**REF0:1 Clock Output (Lump Capacitance Test Load = 20 pF)**

Parameter	Description	Test Condition/Comments	CPU = 66.6/100.2 MHz			Unit
			Min.	Typ.	Max.	
f	Frequency, Actual	Frequency generated by crystal oscillator	14.318			MHz
t <sub>R</sub>	Output Rise Edge Rate	Measured from 0.4V to 2.4V	0.5	–	2	V/ns
t <sub>F</sub>	Output Fall Edge Rate	Measured from 2.4V to 0.4V	0.5	–	2	V/ns
t <sub>D</sub>	Duty Cycle	Measured on rising and falling edge at 1.5V	45	–	55	%
f <sub>ST</sub>	Frequency Stabilization from Power-up (cold start)	Assumes full supply voltage reached within 1 ms from power-up. Short cycles exist prior to frequency stabilization.	–	–	3	ms
Z <sub>o</sub>	AC Output Impedance	Average value during switching transition. Used for determining series termination value.	–	40	–	Ω

**48-MHz Clock Output (Lump Capacitance Test Load = 20 pF = 66.6/100 MHz)**

Parameter	Description	Test Condition/Comments	CPU = 66.6/100.2 MHz			Unit
			Min.	Typ.	Max.	
f	Frequency, Actual	Determined by PLL divider ratio (see p/q below)	–48.008–			MHz
f <sub>D</sub>	Deviation from 48 MHz	(48.008 – 48)/48	+167			ppm
p/q	PLL Ratio	(14.31818 MHz x 57/17 = 48.008 MHz)	–57/17			
t <sub>R</sub>	Output Rise Edge Rate	Measured from 0.4V to 2.4V	0.5	–	2	V/ns
t <sub>F</sub>	Output Fall Edge Rate	Measured from 2.4V to 0.4V	0.5	–	2	V/ns
t <sub>D</sub>	Duty Cycle	Measured on rising and falling edge at 1.5V	45	–	55	%
f <sub>ST</sub>	Frequency Stabilization from Power-up (cold start)	Assumes full supply voltage reached within 1 ms from power-up. Short cycles exist prior to frequency stabilization.	–	–	3	ms
Z <sub>o</sub>	AC Output Impedance	Average value during switching transition. Used for determining series termination value.	–	40	–	Ω

**24-MHz Clock Output (Lump Capacitance Test Load = 20 pF = 66.6/100 MHz)**

Parameter	Description	Test Condition/Comments	CPU = 66.6/100.2 MHz			Unit
			Min.	Typ.	Max.	
f	Frequency, Actual	Determined by PLL divider ratio (see p/q below)	24.004			MHz
f <sub>D</sub>	Deviation from 24 MHz	(24.004 – 24)/24	+167			ppm
p/q	PLL Ratio	(14.31818 MHz x 57/34 = 24.004 MHz)	57/34			
t <sub>R</sub>	Output Rise Edge Rate	Measured from 0.4V to 2.4V	0.5	–	2	V/ns
t <sub>F</sub>	Output Fall Edge Rate	Measured from 2.4V to 0.4V	0.5	–	2	V/ns
t <sub>D</sub>	Duty Cycle	Measured on rising and falling edge at 1.5V	45	–	55	%

**24-MHz Clock Output (Lump Capacitance Test Load = 20 pF= 66.6/100 MHz (continued))**

Parameter	Description	Test Condition/Comments	CPU = 66.6/100.2 MHz			Unit
			Min.	Typ.	Max.	
$f_{ST}$	Frequency Stabilization from Power-up (cold start)	Assumes full supply voltage reached within 1 ms from power-up. Short cycles exist prior to frequency stabilization.	–	–	3	ms
$Z_o$	AC Output Impedance	Average value during switching transition. Used for determining series termination value.	–	40	–	$\Omega$

**Ordering Information**

Ordering Code	Package Type
W144H	48-Pin SSOP (300-mil)
W144HT	48-Pin SSOP (300-mil) – Tape and Reel

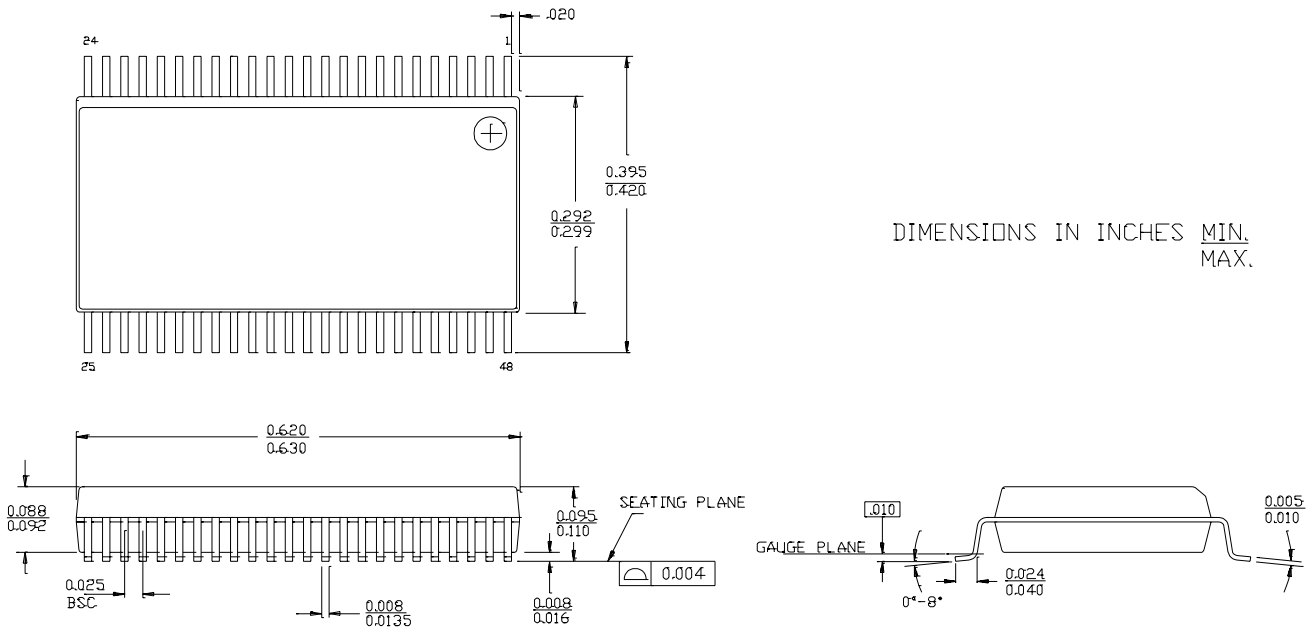
**Package Drawing and Dimension**
**48-Lead Shrunken Small Outline Package O48**

51-85061-°C

Intel is a registered trademark of Intel Corporation. Purchase of I<sup>2</sup>C components from Cypress, or one of its sublicensed Associated Companies, conveys a license under the Philips I<sup>2</sup>C Patent Rights to use these components in an I<sup>2</sup>C system, provided that the system conforms to the I<sup>2</sup>C Standard Specification as defined by Philips. All product and company names mentioned in this document are the trademarks of their respective holders.

**Document History Page Document History Page**

Document Title: W144 440BX AGPset Spread Spectrum Frequency Synthesizer				
Document Number: 38-07153				
REV.	ECN No.	Issue Date	Orig. of Change	Description of Change
**	110263	12/15/01	SZV	Change from Spec number: 38-00791 to 38-07153
*A	122800	12/14/02	RBI	Added Power-up Requirements to Operating Conditions information
*B	131400	01/20/04	RGL/TUJ	<p>Changed the frequency of FS(3:0), 1111 address(CPU_F,CPU1) from 133.3 MHz to 133.6 MHz, (PCI_F) from 33.3 MHz to 33.4 MHz in the pin-selectable Frequency table and in Additional Frequency Selection tables respectively.</p> <p>Changed the frequency of FS(3:0), 0111 address(CPU_F,CPU1) from 100 MHz to 100.2 MHz, (PCI_F) from 33.3 MHz to 33.4 MHz in the Pin selectable Frequency table and in Additional Frequency Selection tables respectively.</p> <p>Changed the min. <math>t_p</math> (period) parameter for 100.2 MHz frequency from 10.0 ns to 9.98 ns in the CPU Clock Outputs table.</p> <p>hanged the min. <math>t_p</math> (period) parameter for 100.2 MHz frequency from 30 ns to 29.9 ns in the PCI Clock Outputs table.</p> <p>Removed "PRELIMINARY"</p>